



# 1 Characteristics

**Table 1. Absolute Ratings** (limiting values)

Symbol	Parameter and test conditions	Value	Unit
$T_j$	Maximum junction temperature	125	°C
$T_{op}$	Operating temperature range	- 40 to + 85	°C
$T_{stg}$	Storage temperature range	- 55 to + 150	°C

**Table 2. Electrical Characteristics** ( $T_{amb} = 25^\circ C$ )

Symbol	Parameter
$V_{BR}$	Breakdown voltage
$I_{RM}$	Leakage current @ $V_{RM}$
$V_{RM}$	Stand-off voltage
$R$	Series resistance between Input and Output
$C_{line}$	Input capacitance per line

The graph plots current  $I$  on the vertical axis against voltage  $V$  on the horizontal axis. The curve shows a sharp increase in current at the breakdown voltage  $V_{BR}$ . Key points on the graph include  $V_{BR}$ ,  $V_{RM}$ ,  $I_R$ , and  $I_{RM}$ .

Symbol	Test conditions	Min.	Typ.	Max.	Unit
$V_{BR}$	$I_R = 1 \text{ mA}$	6	8	10	V
$I_{RM}$	$V_{RM} = 3 \text{ V per line}$			500	nA
$R$	$I = 10 \text{ mA}$	80	100	120	$\Omega$
$C_{line}$	$V_R = 3 \text{ V DC}$ $1 \text{ MHz}$ $V_{OSC} = 30 \text{ mV}$		16	19	pF

Figure 1. S21 (db) attenuation measurement

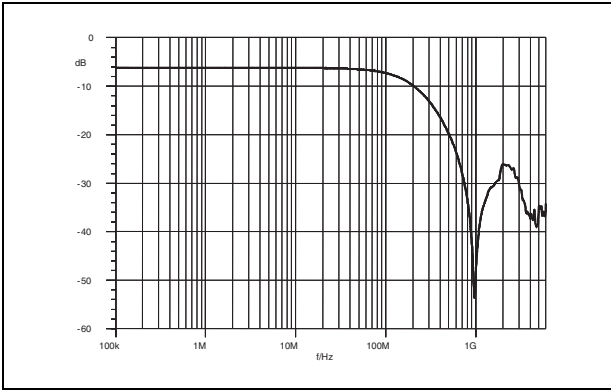

Figure 2. Analog crosstalk measurement

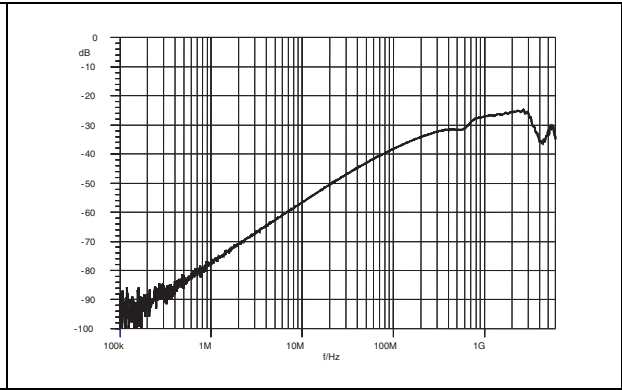

Figure 3. ESD response to IEC 61000-4-2 (+15kV air discharge) on one input (Vin) and on one output (Vout)

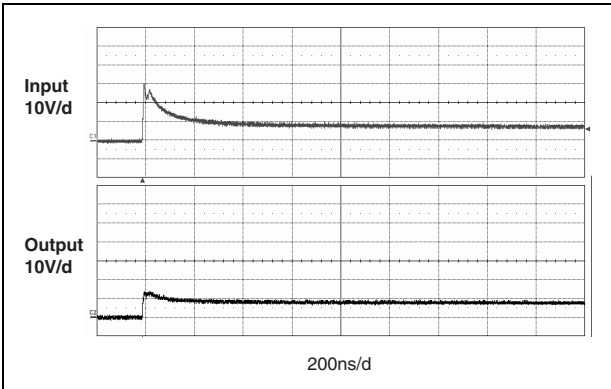

Figure 4. ESD response to IEC 61000-4-2 (-15kV air discharge) on one input (Vin) and on one output (Vout)

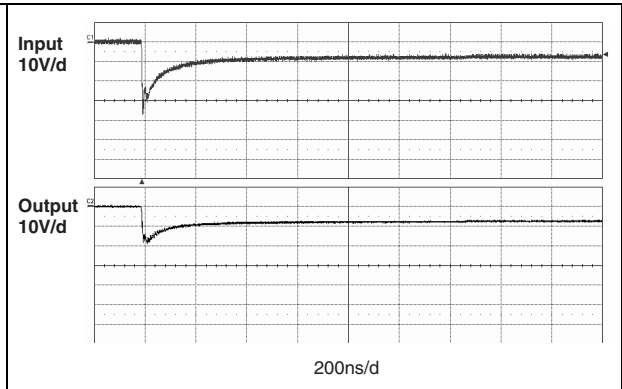
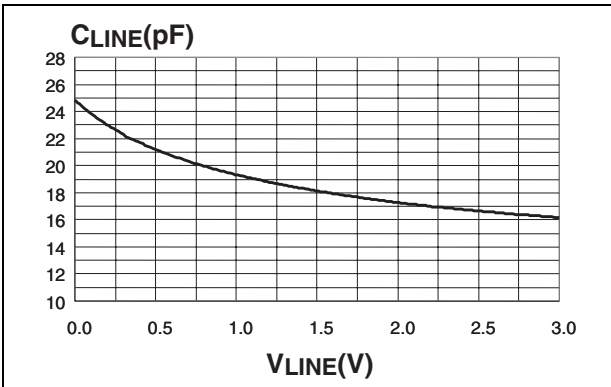
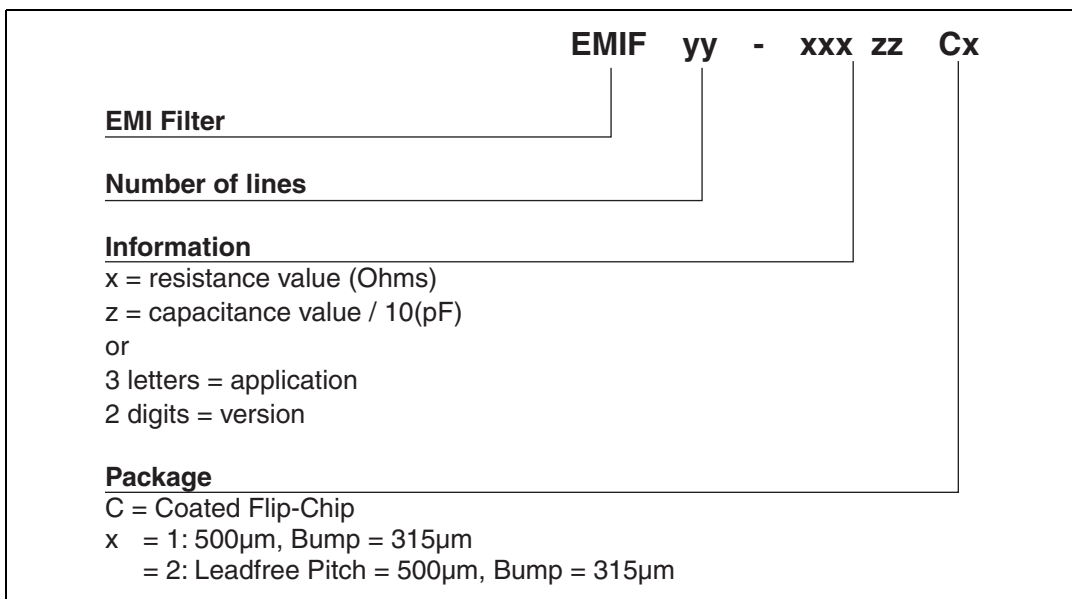

Figure 5. Junction capacitance versus reverse voltage applied (typical values)



## 2 Ordering information scheme



## 3 Package information

Figure 6. Flip-Chip Dimensions

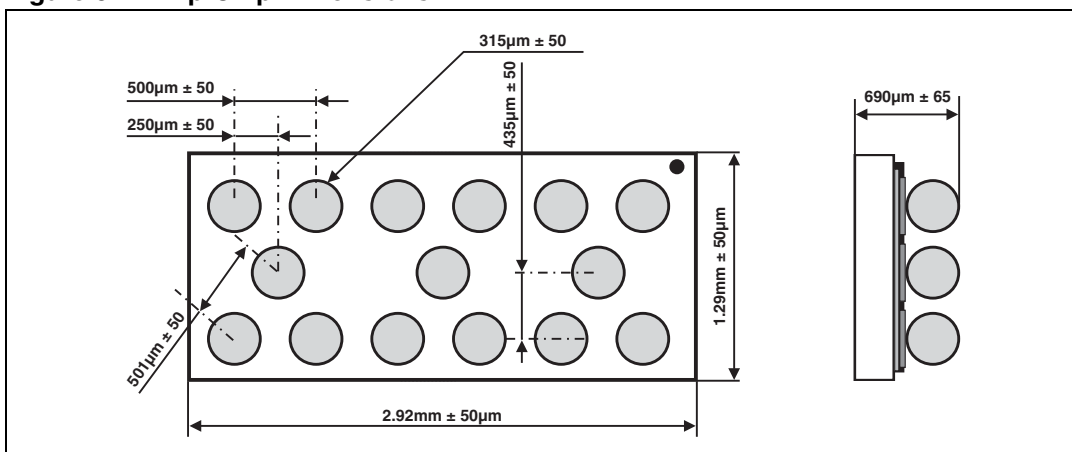

**Figure 7. Footprint recommendations** **Figure 8. Marking**

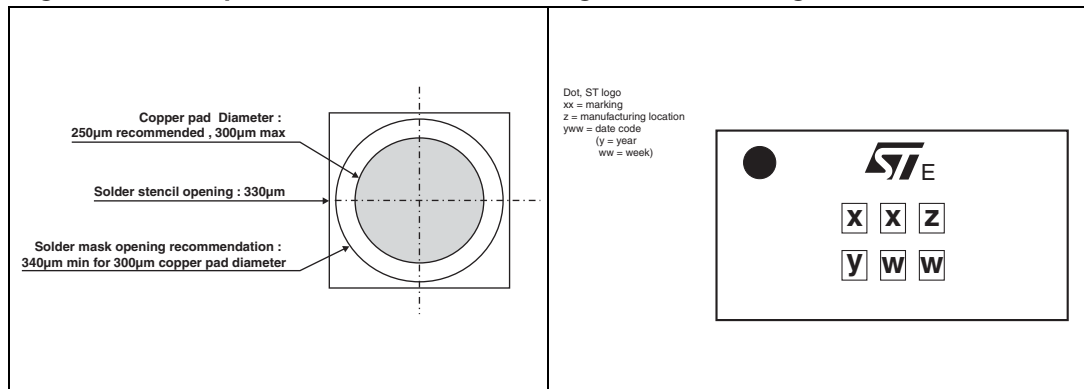

**Figure 9. Flip-Chip Tape and reel specifications**

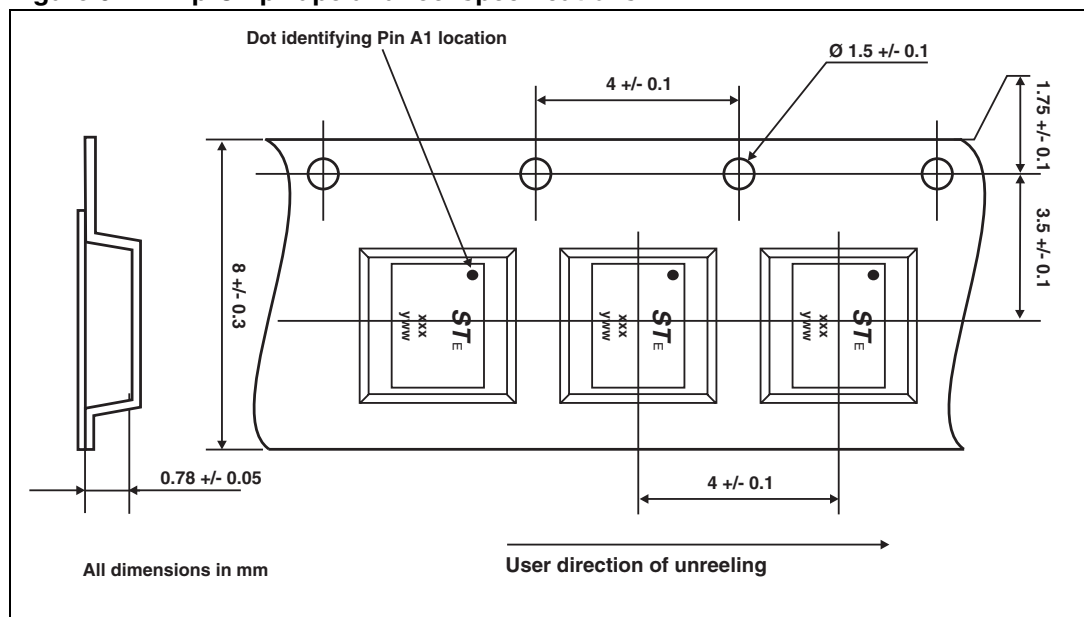

In order to meet environmental requirements, ST offers these devices in ECOPACK® packages. These packages have a lead-free second level interconnect. The category of second level interconnect is marked on the package and on the inner box label, in compliance with JEDEC Standard JESD97. The maximum ratings related to soldering conditions are also marked on the inner box label. ECOPACK is an ST trademark. ECOPACK specifications are available at: [www.st.com](http://www.st.com).

*Note:* More packing informations are available in the application note  
 AN1235: “Flip-Chip: Package description and recommendations for use”  
 AN1751: “EMI Filters: Recommendations and measurements”

## 4 Ordering information

Ordering code	Marking	Package	Weight	Base qty	Delivery mode
EMIF06-VID01C2	GR	Flip-Chip	5.9 mg	5000	Tape and reel 7"

## 5 Revision history

Date	Revision	Changes
12-Aug-2005	1	First issue.
01-Jun-2006	2	Reformatted to current standards. Modified marking illustration to remove dimensions. Depth dimension changed in Figure 9.

**Please Read Carefully:**

Information in this document is provided solely in connection with ST products. STMicroelectronics NV and its subsidiaries ("ST") reserve the right to make changes, corrections, modifications or improvements, to this document, and the products and services described herein at any time, without notice.

All ST products are sold pursuant to ST's terms and conditions of sale.

Purchasers are solely responsible for the choice, selection and use of the ST products and services described herein, and ST assumes no liability whatsoever relating to the choice, selection or use of the ST products and services described herein.

No license, express or implied, by estoppel or otherwise, to any intellectual property rights is granted under this document. If any part of this document refers to any third party products or services it shall not be deemed a license grant by ST for the use of such third party products or services, or any intellectual property contained therein or considered as a warranty covering the use in any manner whatsoever of such third party products or services or any intellectual property contained therein.

**UNLESS OTHERWISE SET FORTH IN ST'S TERMS AND CONDITIONS OF SALE ST DISCLAIMS ANY EXPRESS OR IMPLIED WARRANTY WITH RESPECT TO THE USE AND/OR SALE OF ST PRODUCTS INCLUDING WITHOUT LIMITATION IMPLIED WARRANTIES OF MERCHANTABILITY, FITNESS FOR A PARTICULAR PURPOSE (AND THEIR EQUIVALENTS UNDER THE LAWS OF ANY JURISDICTION), OR INFRINGEMENT OF ANY PATENT, COPYRIGHT OR OTHER INTELLECTUAL PROPERTY RIGHT.**

**UNLESS EXPRESSLY APPROVED IN WRITING BY AN AUTHORIZED REPRESENTATIVE OF ST, ST PRODUCTS ARE NOT DESIGNED, AUTHORIZED OR WARRANTED FOR USE IN MILITARY, AIR CRAFT, SPACE, LIFE SAVING, OR LIFE SUSTAINING APPLICATIONS, NOR IN PRODUCTS OR SYSTEMS, WHERE FAILURE OR MALFUNCTION MAY RESULT IN PERSONAL INJURY, DEATH, OR SEVERE PROPERTY OR ENVIRONMENTAL DAMAGE.**

Resale of ST products with provisions different from the statements and/or technical features set forth in this document shall immediately void any warranty granted by ST for the ST product or service described herein and shall not create or extend in any manner whatsoever, any liability of ST.

ST and the ST logo are trademarks or registered trademarks of ST in various countries.

Information in this document supersedes and replaces all information previously supplied.

The ST logo is a registered trademark of STMicroelectronics. All other names are the property of their respective owners.

© 2006 STMicroelectronics - All rights reserved

STMicroelectronics group of companies

Australia - Belgium - Brazil - Canada - China - Czech Republic - Finland - France - Germany - Hong Kong - India - Israel - Italy - Japan - Malaysia - Malta - Morocco - Singapore - Spain - Sweden - Switzerland - United Kingdom - United States of America

[www.st.com](http://www.st.com)