

6-line IPAD™, EMI filter and ESD protection for SD card

Features

- ESD protection (IEC standard)
- EMI Filtering
- Level translator
- Signal conditioning
- Integrated power supply with:
 - Thermal shutdown (TSD)
 - Under voltage lockout (UVLO)
 - Short-circuit current limitation (I_{SC})
 - Power on/off feature with Enable pin

Benefits

- EMI Low-pass-filter and ESD protection (up to 15 kV on external pins)
- Integrated pull up resistors prevent bus floating
- 50 MHz clock frequency compatible with $C_{line} < 40$ pF
- Lead-free package in 400 μ m pitch
- Low power consumption
- Very low PCB space consumption
- High reliability offered by monolithic integration
- Reduction of parasitic elements thanks to CSP integration

Complies with the following standards:

- IEC 61000-4-2, Level 4: External pins
 - 15 kV (air discharge)
 - 8 kV (contact discharge)
- HBM IEC 61340-3-1: All pins
 - 2 kV (air discharge)
 - 2 kV (contact discharge)

TM: IPAD is a trademark of STMicroelectronics.

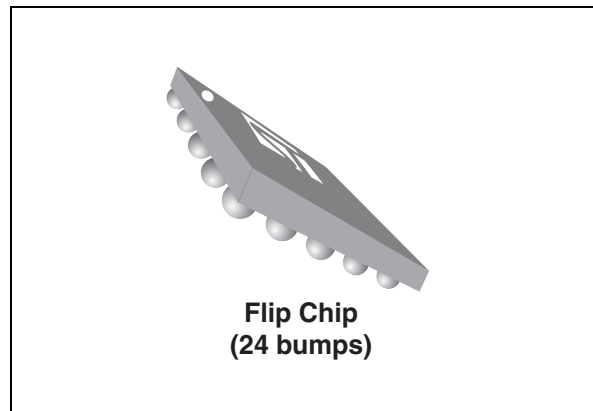
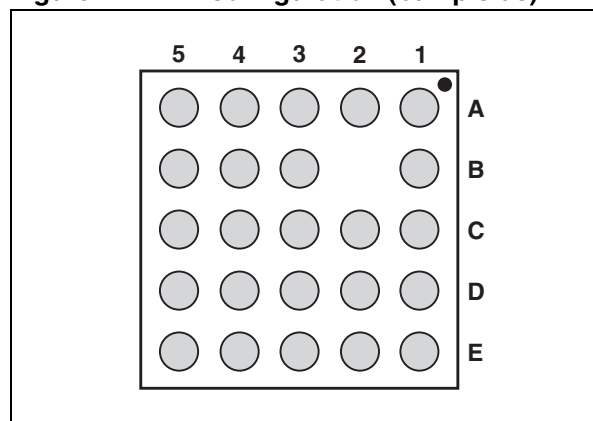

Figure 1. Pin configuration (bump side)



Applications

- Removable memory cards in mobile phones, communication systems, and portable applications
- Memory cards compliant with: SD (standard and high speed), MiniSD, μ SD and MMC/Trans-flash standards

Description

The EMIF06-SD03F3 is a highly integrated device, based on IPAD technology, combining the 5 functions described under [Features](#).

Contents

- 1 Functional description 3**
- 2 Characteristics 6**
- 3 Passive integration and low pass filter 8**
- 4 Data transmission 10**
 - 4.1 Test circuit from host to SD 11
 - 4.2 Test circuit from SD to host 12
 - 4.3 Measurement of t_{skew} (host to SD) from rising edge CLK.h 12
 - 4.4 Measurement of $t_{skew.f}$ (read mode) from rising edge CLK.h 13
- 5 Low drop out voltage regulator 14**
 - 5.1 Line regulation and transient line regulation 17
 - 5.2 Load regulation and transient load regulation 18
 - 5.3 Dropout definition 19
- 6 Application schematic 19**
- 7 Ordering information scheme 20**
- 8 Package information 20**
- 9 Ordering information 21**
- 10 Revision history 22**

1 Functional description

A SIDE (Host-CPU) pin list:

V_{ccA} , Enable, Dat123.dir, CMD.dir, CMD.h, CLK.h, CLK -f, Dat0.dir, Dat0.h, Dat1.h, Dat2.h, Dat3.h, V_{bat}

B SIDE (SD-Card) pin list:

WP, CD, V_{ccB} , CMD-B, CLK-B, Dat0-B, Dat1-B, Dat2-B, Dat3-B

Table 1. Pin definition

Pin name	Bump	Type	Side	Description
V_{ccA}	B3	Power input	A	Power supply (1.8v)
V_{ccB}	B4	Power output	B	Power supply (internally generated, 2.9 V)
V_{bat}	A4	Power input	A	Battery power supply
GND	C4	Ground	-	Ground
GND	C3	Ground	-	Ground
Enable	C2	Input	A	Internal power supply enable
CMD.dir	A2	Input	A	Command direction
CMD.h	D2	IO	A	A side command
CLK.h	C1	Input	A	Clock input
CLK-f	E2	Output	A	Clock feedback
Dat0.dir	A3	Input	A	Data direction
Dat0.h	D1	IO	A	Data host
Dat123.dir	E3	Input	A	Data direction
Dat1.h	E1	IO	A	Data host
Dat2.h	A1	IO	A	Data host
Dat3.h	B1	IO	A	Data host
WP	E4	Input to CPU	A	Write protect
CD	D3	Input to CPU	A	Card detect
CMD-B	D4	IO	B	Command direction
CLK-B	C5	Output	B	Clock output
Dat0-B	D5	IO	B	Data SD
Dat1-B	E5	IO	B	Data SD
Dat2-B	A5	IO	B	Data SD
Dat3-B	B5	IO	B	Data SD

Note: In Table 5, 6, 7, and 10, collective names are used for groups of pins. The names used are:

*.dir = CMD.dir, Dat0.dir, Dat123.dir

*.h = CMD.h, CLK.h, Dat0.h, Dat1.h, Dat2.h, Dat3.h

*-B = CMD-B, CLK-B, Dat0-B, Dat1-B, Dat2-B, Dat3-B

V_{iA} = All A side input pins

V_{iB} = All B side input pins.

Table 2. Function table

Command signals				A side signals direction					B side signal direction			
Enable	CMD.dir	Dat0.dir	Dat123.dir	CMD.h	CLK.h	CLK-f	Dat0.h	Dat1.h Dat2.h Dat3.h	CMD-B	CLK-B	Dat0-B	Dat1-B Dat2-B Dat3-B
H	H	X	X	IN	IN	OUT	X	X	OUT	OUT	X	X
H	L	X	X	OUT	IN	OUT	X	X	IN	OUT	X	X
H	X	H	X	X	IN	OUT	IN	X	X	OUT	OUT	X
H	X	L	X	X	IN	OUT	OUT	X	X	OUT	IN	X
H	X	X	H	X	IN	OUT	X	IN	X	OUT	X	OUT
H	X	X	L	X	IN	OUT	X	OUT	X	OUT	X	IN
L	X	X	X	X	X	Z	X	X	L*	Z	L*	L*

- Note: 1 When A side signals direction is INPUT, SD-CARD is WRITTEN by CPU-Host (i.e B side signals direction is OUTPUT)
 When A side signals direction is OUTPUT, SD-CARD is READ by CPU-Host (i.e B side signals direction is INPUT)
- 2 For B side signals when Enable = L:
 * Defined by internal pull-down (see Figure 3 for pins CMD.B and data bus Dat[0...3].B)

Figure 2. Configuration

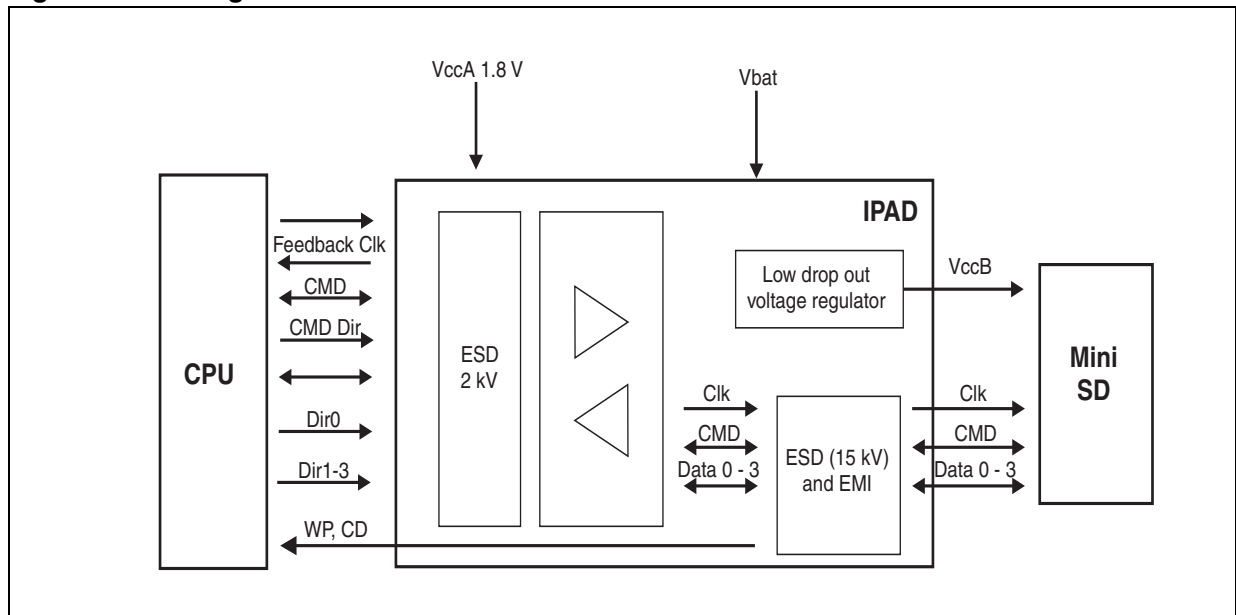
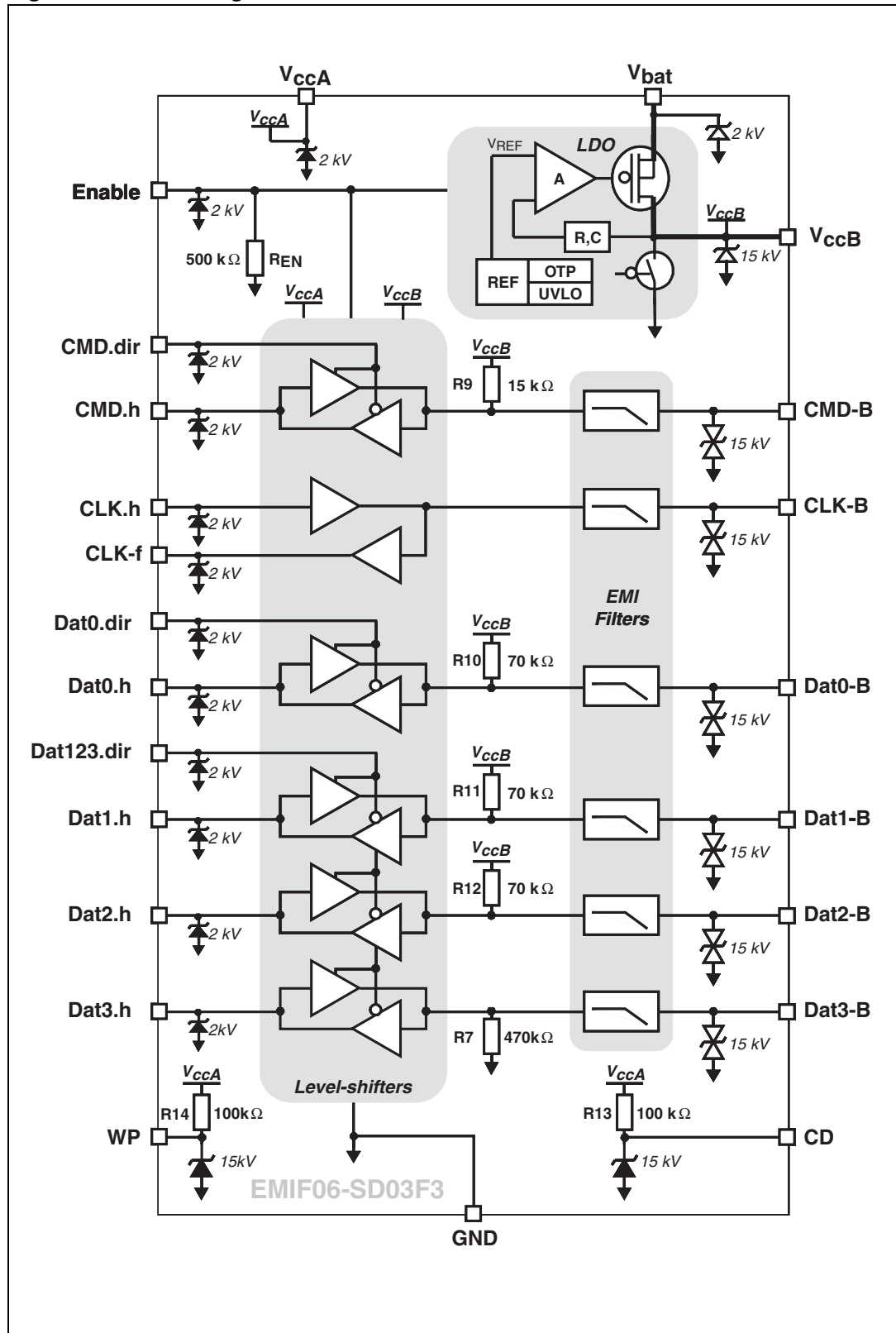

Figure 3. Block diagram



2 Characteristics

Table 3. Absolute maximum ratings

Symbol	Parameter	Value	Unit
ESD	A SIDE (Host-CPU) All pins: HBM IEC61340-3-1 V _{ccA} , Enable, Dat123.dir, CMD.dir, CMD.h, CLK.h, CLK -f, Dat0.dir, Dat0.h, Dat1.h, Dat2.h, Dat3.h, V _{bat}	Air discharge: 2 Contact discharge: 2	kV
	B SIDE (SD-Card) External pins : IEC 61000-4-2, level 4 V _{ccB} , CMD-B, CLK-B, Dat0-B, Dat1-B, Dat2-B, Dat3-B, WP, CD	Air discharge: 15 Contact discharge: 8	
T _{jmax}	Maximum junction temperature	150	°C
R _{th (j-a)} ⁽¹⁾	Thermal resistance from junction to ambient Board: Epoxy FR4, copper thickness = 40 μm, 4 layers	64	°C/W
P _{dmax}	Maximum power dissipation: $P_{dmax} = (T_{jmax} - T_{aopmax}) / R_{th (j-a)}$	1	W
T _{stg}	Storage temperature range	-55 to +150	°C
Voltage	V _{bat} , V _{ccB} , Enable	-0.3 to 5.5V	V
	CMD-B, CLK-B, Dat0-B, Dat1-B, Dat2-B, Dat3-B	-0.3 to V _{ccB} + 0.3	
	V _{ccA}	-0.3 to 3.3	
	Dat123.dir, CMD.dir, CMD.h, CLK.h, CLK -f, Dat0.dir, Dat0.h, Dat1.h, Dat2.h, Dat3.h, WP, CD	-0.3 to V _{ccA} +0.3	

1. V_{ccB} is an internally generated power supply, no external voltage should be applied on this pin other than a current clamp. The thermal resistance depends on printed circuit board layout. To dissipate the heat efficiently away from Flip Chip bumps, it is better to make copper planes the largest possible as well as considering thermal vias usage.

Table 4. Recommended operating conditions

Symbol	Parameter	Conditions	Min.	Typ.	Max.	Unit
V _{ccA}	Power supply		1.62	1.8	1.92	V
V _{bat}	Battery power supply		3.1	-	5	V
I _{out}	V _{ccB} output current		0.10	100	200	mA
C _{bat}	External battery capacitance	Ceramic capacitor	-	2.20	-	μF
C _{out} ⁽¹⁾	External output capacitance	T _a = -40 °C to +85 °C, V _{bias} = 0 V to 3.3 V Multi-layer ceramic capacitor type like: C20RX7R1C225K	1.4 (-35%)	2.20	3.0 (+35%)	μF
ESR ⁽²⁾	Equivalent series resistance for C _{out}	F = 1 Hz to 10 MHz Multi-layer ceramic capacitor type like: C2012X7R1C225KT	-	3	200	mΩ
T _{aop}	Ambient operating temperature		-30	25	85	°C
T _{jop}	Junction operating temperature		-30	25	125	°C
P _{dop}	Maximum power dissipation	P _{dop} = (T _{jop} - T _{aop})/R _{th(j-a)}	-	-	625	mW
Enable	Enable input voltage		0	-	V _{ccA}	V
External pins (without WP and CD)	CMD-B, CLK-B, Dat0-B, Dat1-B, Dat2-B, Dat3-B		0	-	V _{ccB}	V
Internal pins (except Enable, with WP and CD)	WP, CD, Dat123.dir, CMD.dir, CMD.h, CLK.h, CLK-f, Dat0.dir, Dat0.h, Dat1.h, Dat2.h, Dat3.h		0	-	V _{ccA}	V

1. C_{out} = 2.2 μF is minimum allowable capacitance value to guarantee LDO stability
2. Values for ESR include the V_{ccB} - C_{out} resistance path and C_{out} - GND resistance path. These resistance paths need to be minimized in PCB design.

Table 5. LDO - current levels in recommended operating conditions

Symbol	Parameter	Test conditions ⁽¹⁾	Min.	Typ.	Max.	Unit	
I _{Q_OFF}	Quiescent current consumption I _{ccA_OFF}	V _{EN} = 0.4 V, V _{bat} = 3.4 V, V _{ccA} = 1.92 V *.dir, *.h, *-B = GND, WP = CD = V _{ccA} All other pins floating	-	-	1	μA	
	Quiescent current consumption I _{bat_OFF}	V _{EN} = 0.4 V, V _{bat} = 5 V, V _{ccA} = 1.92 V *.dir, *.h, *-B = GND All other pins floating	-	-	1	μA	
I _{Q_ON}	Quiescent current consumption (Ground pin current) I _{bat} + I _{ccA}	Level shifter deactivated *.dir = 0 V, V _{bat} = 3.4 V V _{EN} = V _{ccA} = V _{CLK.h} = 1.8 V All other pins floating	I _{out} = 100 μA	-	160	220	μA
			I _{out} = 50 mA	-	320	375	μA
			I _{out} = 100 mA	-	470	550	μA
			I _{out} = 200 mA	-	750	900	μA

1. See *Note: on page 3* for definition of collective names of pins, for example *.dir

Table 6. Level shifter - current levels in recommended operating conditions

Symbol	Parameter	Test conditions ⁽¹⁾	Min.	Typ.	Max.	Unit
I _{ccA_ON}	Quiescent current on V _{ccA}	V _{EN} = V _{ccA} = 1.92 V, V _{bat} = 3.4 V *.dir = V _{ccA} , ViA = *.h = V _{ccA}	-	3	10	μA
I _{ccB_ON}	Quiescent current on V _{ccB}	V _{EN} = V _{ccA} = 1.92 V, V _{bat} = 3.4 V *.dir = 0 V, V _{ccB} = 3.05 V, ViB = V _{ccB}	-	15	30	μA

1. See *Note: on page 3* for definition of collective names of pins, for example *.dir

3 Passive integration and low pass filter

Figure 4. Circuit diagram of EMIF06-SD03F3 (without LDO)

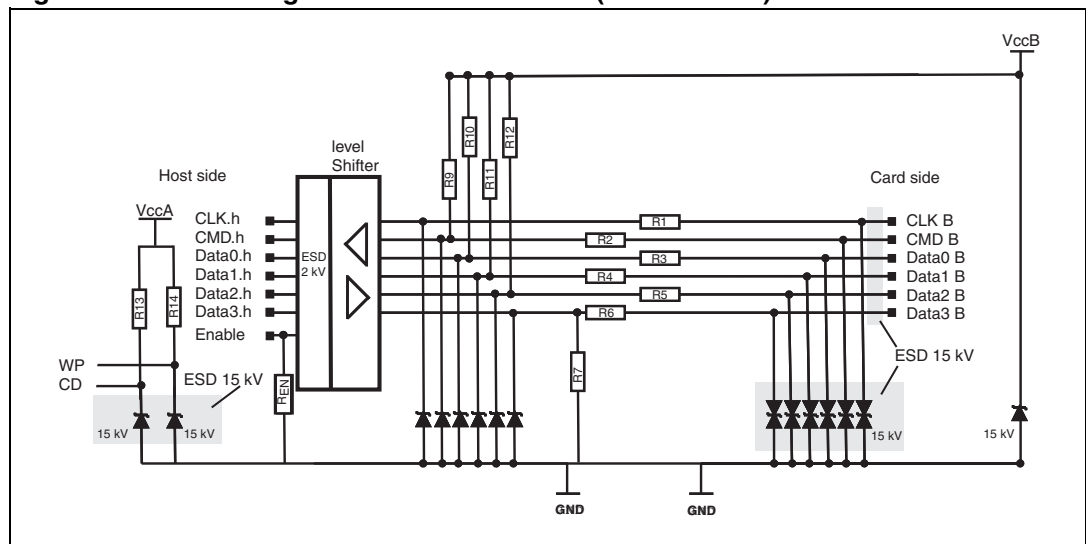

Note: V_{BR} in 14 V technology for pins: CMD-B, CLK-B, Dat0-B, Dat1-B, Dat2-B, Dat3-B, WP, CD
V_{BR} in 8 V technology for pins: Vcc-B, CLK.h, CLK-f, CMD.h, Dat0.h, Dat1.h, Dat2.h, Dat3.h

Table 7. Components

Symbol	Parameter	Test conditions ⁽¹⁾	Min.	Typ.	Max.	Unit
C_{in-A}	Input capacitance for A side	$V_{bat} = 3.4\text{ V}$, *.dir = $V_{EN} = V_{CCA}$ $F = 1\text{ MHz}$, $V_{dc} = 0\text{ V}$, $\pm 30\text{ mV}$, $V_{AC} = 30\text{ mV}$	-	5	10	pF
C_{in-B}	Input capacitance for B side	$V_{bat} = 3.4\text{ V}$, *.dir = GND, $V_{EN} = V_{CCA}$ $F = 1\text{ MHz}$, $V_{dc} = 0\text{ V}$, $\pm 30\text{ mV}$, $V_{AC} = 30\text{ mV}$	-	25	35	pF
C_{EMIF}	Capacitance seen on B side from EMIF filter		-	15	-	pF
R1, R2, R3, R4, R5, R6 ⁽²⁾	EMIF resistors ⁽³⁾	$T_j = 25\text{ }^\circ\text{C}$	-	40	-	Ω
R_{line}	Line resistance	at 20 mA	40	50	60	Ω
R10, R11, R12	EMIF resistors ⁽⁴⁾	$T_j = 25\text{ }^\circ\text{C}$	49	70	91	k Ω
R9	EMIF resistor ⁽⁴⁾	$T_j = 25\text{ }^\circ\text{C}$	10.5	15	19.5	k Ω
R7	EMIF resistor ⁽⁴⁾	$T_j = 25\text{ }^\circ\text{C}$	329	470	611	k Ω
R13	EMIF resistor ⁽⁴⁾	$T_j = 25\text{ }^\circ\text{C}$	70	100	130	k Ω
R14	EMIF resistor ⁽⁴⁾	$T_j = 25\text{ }^\circ\text{C}$	70	100	130	k Ω
R_{EN}	resistor ⁽⁴⁾	$T_j = 25\text{ }^\circ\text{C}$	-	500	-	k Ω

1. See [Note: on page 3](#) for definition of collective names of pins, for example *.dir
2. These values are guaranteed by design and statistical process control.
3. 20% tolerance in resistance value
4. 30% tolerance in resistance value

Figure 5. Frequency response with level shifters internally bypassed⁽¹⁾

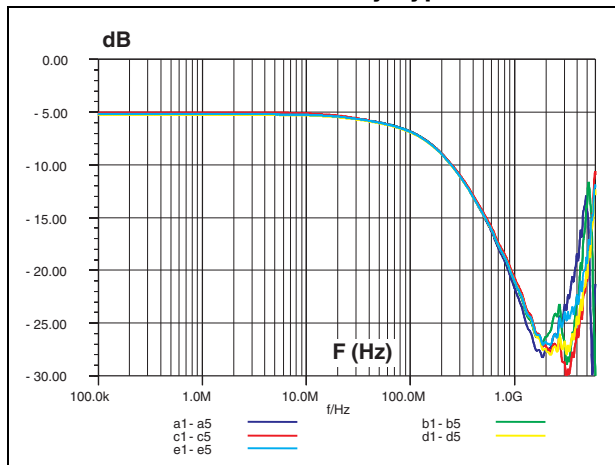
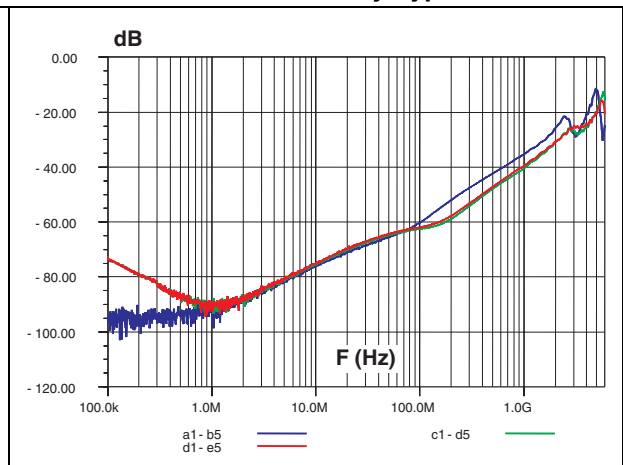

Figure 6. Crosstalk response with level shifters internally bypassed⁽¹⁾



1. Measurement in 50 Ω environment

4 Data transmission

All values in the tables below are guaranteed across the operating temperature and voltage range unless otherwise specified.

Table 8. DC voltage levels on host side

Symbol	Parameter	Test conditions	Min.	Typ.	Max.	Unit
V _{IHA}	High level input voltage		0.65 x V _{CCA}	V _{CCA}	-	V
V _{ILA}	Low level input voltage		0	0	0.35 x V _{CCA}	V
V _{OHA}	High level output voltage	I _{oh} = -6 mA	V _{CCA} - 0.45	-	-	V
V _{OLA}	Low level output voltage	I _{ol} = 7 mA	-	0	0.45	V

Table 9. DC voltage levels on SD side

Symbol	Parameter	Test conditions	Min.	Typ.	Max.	Unit
V _{IHB}	High level input voltage		0.7 x V _{CCB} ⁽¹⁾	V _{CCB}	-	V
V _{ILB}	Low level input voltage		-	0	0.3 x V _{CCB} ⁽¹⁾	V
V _{OHB}	High level output voltage	I _{oh} = -8 mA	V _{CCB} ⁽¹⁾ - 0.7	2.9	-	V
V _{OLB}	Low voltage output voltage	I _{ol} = 8 mA	-	0	0.7	V

1. V_{CCB} is defined in power supply block.

Table 10. DC current levels

Symbol	Parameter	Test conditions ⁽¹⁾	Min.	Typ.	Max.	Unit
I _{LH}	Leakage current on host pin	V _{EN} = *.dir = V _{CCA} = 1.92 V, V _{iA} = V _{CCA} or GND, V _{bat} = 3.4 V	-	-	5	μA
I _{LSD}	Leakage current on SD pin	V _{bat} = 3.4 V, V _{CLK.h} = V _{CCA} , V _{CMD} = V _{Dat0} = V _{Dat1} = V _{Dat2} = V _{CCB} V _{Dat3} = *.dir = GND	-	-	5	μA
I _{SCH}	Short circuit current on host side	SD input = H, host = 0 V SD input = 0 V, host = V _{CCA} = 1.8 V *.dir = 0 V, V _{bat} = 3.4 V, T _j = 25 °C	-	25	-	mA
I _{SCSD}	Short circuit current on SD side	Host input = H, SD = 0 V Host input = L, SD = V _{CCB} , T _j = 25 °C *.dir = V _{CCA} = 1.8 V, V _{bat} = 3.4 V	-	60	-	mA

1. See [Note: on page 3](#) for definition of collective names of pins, for example *.dir

Figure 7. Symbol definitions of t_{plh} , t_{pLh} , t_r and t_f for AC characteristics in [Table 11](#)

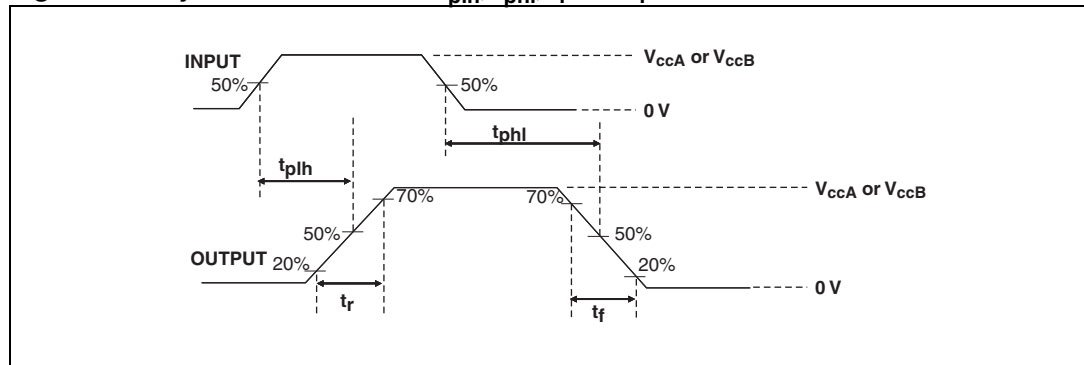

Table 11. AC characteristics⁽¹⁾

Symbol	Parameter	Test conditions	Min.	Typ.	Max.	Unit
t_{pLh}	Propagation delay hL from host to SD	Section 4.1	-	3.5	6	ns
t_{plh}	Propagation delay lh from host to SD					
t_{pLh}	Propagation delay hL from SD to host	Section 4.2	-	3	6	ns
t_{plh}	Propagation delay lh from SD to host					
t_r	Rise time from host to SD	Section 4.1	-	1.5	3	ns
	Rise time from SD to host	Section 4.2	-	0.5	2	
t_f	Fall time from host to SD	Section 4.1	-	1.9	3	ns
	Fall time from SD to host	Section 4.2	-	0.5	2	
t_{skew}	Delay differences from host to SD	Section 4.1, Section 4.3	-1.0	0	1.0	ns
$t_{skew.f}$	t_{skew} delay from SD to host	Section 4.2, Section 4.4	-1.5	0	1.5	ns
t_{p_clkf}	Propagation delay for CLK feedback		-	6.5	12	ns
t_{r_clkf}	Rise time for CLK feedback	Section 4.2	-	0.5	2	ns
t_{f_clkf}	Fall time for CLK feedback	Section 4.2	-	0.5	2	ns

1. T_{aop} -30 to 85 °C, I_{out} = 1 mA, C_{bat} = 2.2 μ F, C_{out} = 2.2 μ F

4.1 Test circuit from host to SD

Test circuit from host to SD is shown in [Figure 8](#). Timings are measured for the whole line cell (shifter + EMI + ESD) on an external load C_{sd} = 15 pF (board capacitance 5 pF + SD card capacitance 10 pF).

Figure 8. Test circuit from host to SD

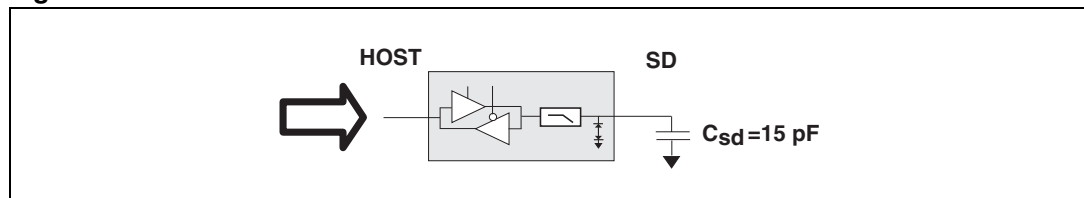

4.2 Test circuit from SD to host

Test circuit from SD to host is shown in *Figure 9*. Timings are measured for the whole line cell (shifter + EMI + ESD) on an external load $C_{host} = 5\text{ pF}$ (board capacitance + host capacitance).

Figure 9. Test circuit from SD to host

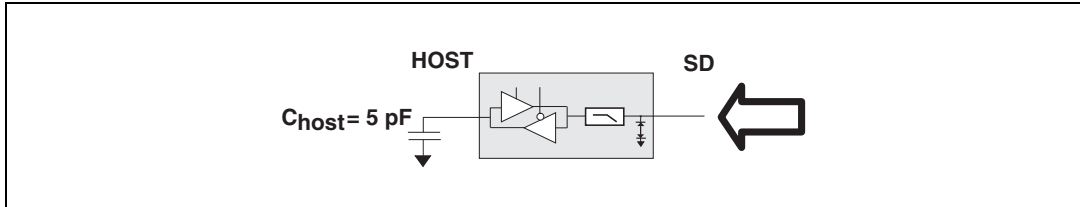

4.3 Measurement of t_{skew} (host to SD) from rising edge CLK.h

Figure 10. Example of measurement of t_{skew} (host to SD) from rising edge of CLK.h

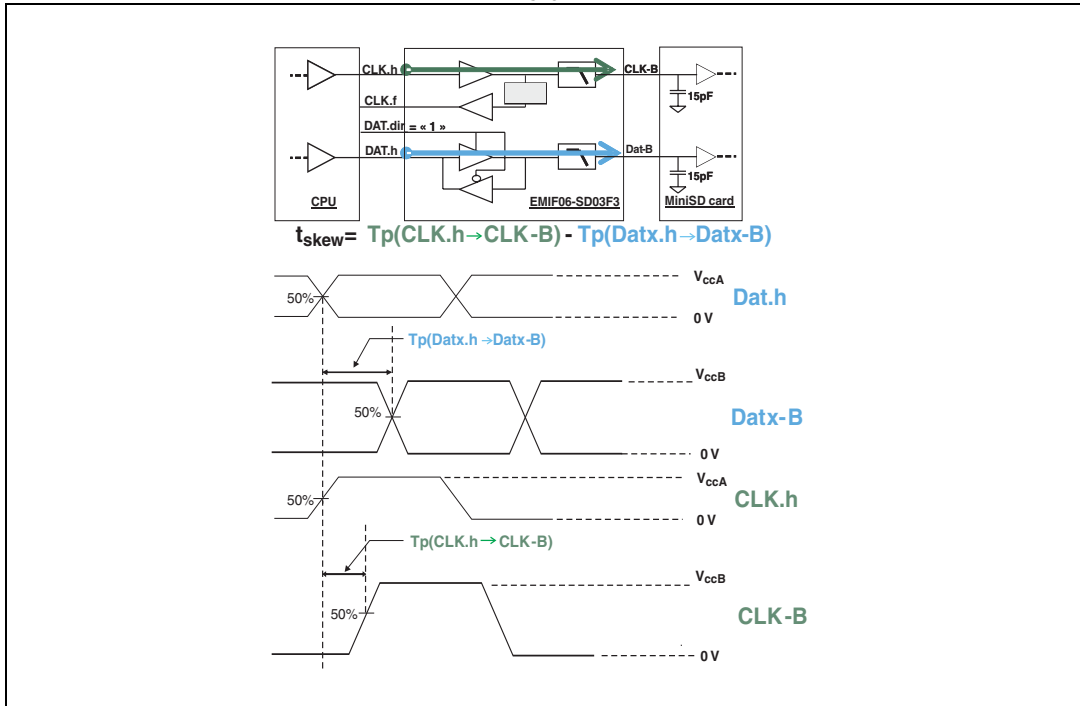

4.4 Measurement of $t_{skew.f}$ (read mode) from rising edge CLK.h

Figure 11. Example of measurement of $t_{skew.f}$ for read mode from rising edge of CLK.h

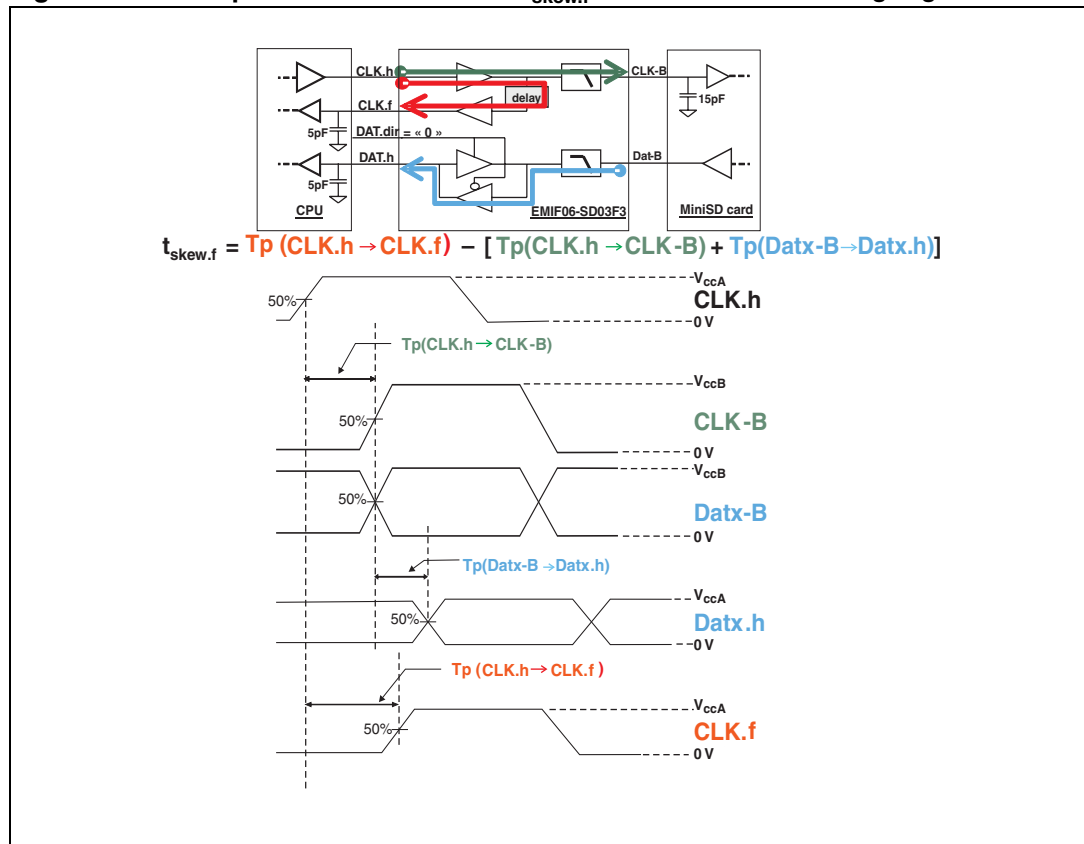

Datx.h = Dat0.h, Dat1.h, Dat2.h, Dat3.h, CMD.h

Datx-B = Dat0-B, Dat1-B, Dat2-B, Dat3-B, CMD.B

5 Low drop out voltage regulator

Figure 12. Low drop out voltage regulator

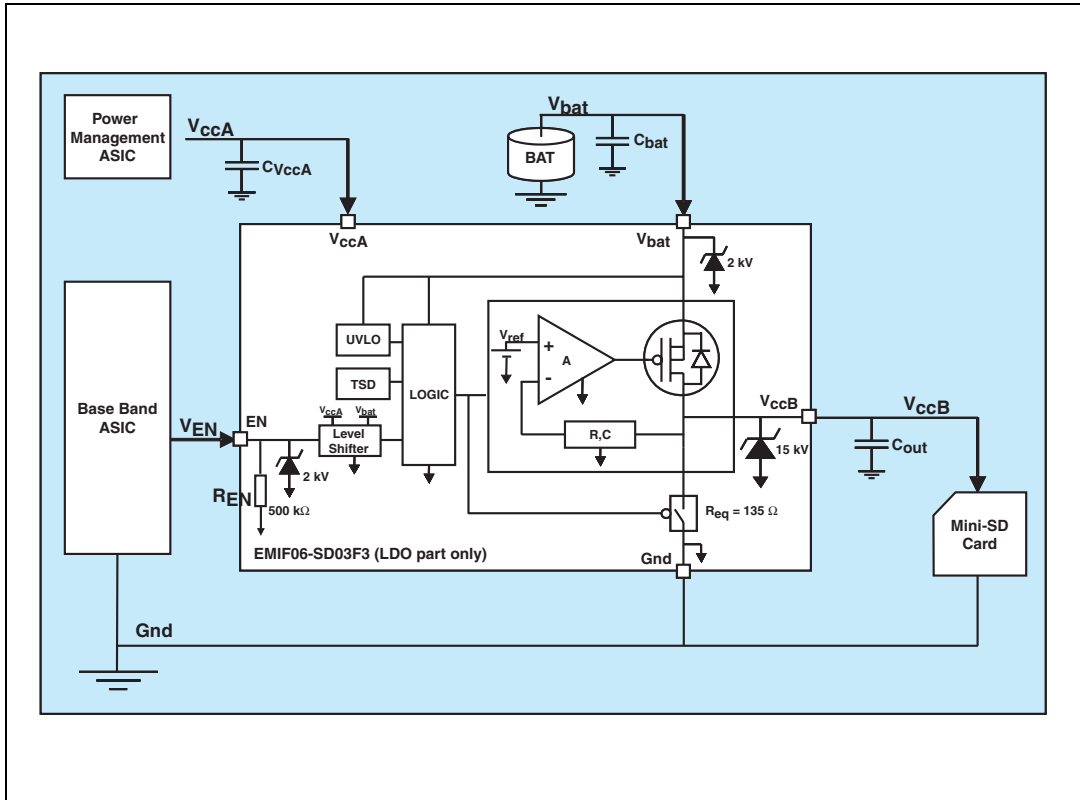

Table 12. Static parameters, $V_{EN} = V_{CCA}$ unless otherwise specified⁽¹⁾

Symbol	Parameter	Test conditions	Min.	Typ.	Max.	Unit	
V_{out}	Regulated output voltage (V_{CCB})	$V_{bat} = 3.4\text{ V}$, $I_{out} = 100\text{ mA}$, $T_j = 25\text{ °C}$	2.81 (-3%)	2.90	2.99 (+3%)	V	
		$V_{bat} = 3.4\text{ V}$, $I_{out} = 100\text{ mA}$, $T_j = -30\text{ to }125\text{ °C}$	2.81 (-3%)	-	2.99 (+3%)	V	
		$V_{bat} = 3.1\text{ to }5\text{ V}$, $I_{out} = 0.1\text{ to }200\text{ mA}$, $T_j = -30\text{ to }125\text{ °C}$	2.75 (-5%)	-	3.05 (+5%)	V	
LiR	Line regulation	$V_{bat} = 3.4\text{ to }5\text{ V}$ (Section 5.1), $I_{out} = 100\text{ mA}$, $T_j = 25\text{ °C}$	-	3	20	mV	
LdR	Load regulation	$V_{bat} = 3.4\text{ V}$, $I_{out} = 1\text{ to }200\text{ mA}$ (Section 5.2), $T_j = 25\text{ °C}$	-	50	100	mV	
V_{DO}	Dropout voltage	$V_{out(nom)} - 100\text{ mV}$ (Section 5.3), $T_j = -30\text{ to }85\text{ °C}$	$I_{out} = 50\text{ mA}$	-	25	37	mV
			$I_{out} = 100\text{ mA}$	-	50	75	mV
			$I_{out} = 200\text{ mA}$	-	100	150	mV
I_{sc}	Short circuit current limitation	$V_{bat} = 5\text{ V}$, $V_{out} = 0\text{ V}$, $T_j = 25\text{ °C}$	-	500	-	mA	
TSD	Thermal shutdown temperature	$V_{bat} = 3.4\text{ V}$	Shutdown (Temp ↑)	-	150	-	°C
			Reset (Temp ↓)	-	130	-	°C
			Hysteresis	-	20	-	°C
UVLO	Under voltage lockout	$T_j = -30\text{ to }125\text{ °C}$	Shutdown ($V_{bat} \downarrow$)	2.3	2.5	2.7	V
			Reset ($V_{bat} \uparrow$)	2.35	2.55	2.75	V
			Hysteresis	-	50	-	mV

1. Level shifter deactivated, *.dir = 0, CLK.h = V_{CCA} , all other pins floating.

Table 13. Dynamic parameters ($V_{EN} = V_{CCA}$ unless otherwise specified)

Symbol	Parameter	Test conditions	Min.	Typ.	Max.	Unit	
LiTr	Line transient peak voltage	$V_{bat} = 3.4\text{ V} \uparrow\downarrow 4\text{ V}$, $t_{tr} = 30\text{ }\mu\text{s}$, $I_{out} = 200\text{ mA}$ $T_j = 25\text{ }^\circ\text{C}$ (Section 5.1) $C_{out} = 2.2\text{ }\mu\text{F}$, $\text{ESR} = 5\text{ m}\Omega$	-	4.2	-	mV	
LdTr	Load transient peak voltage	$I_{out} = 1\text{ mA} \uparrow\downarrow 200\text{ mA}$, $t_{tr} = 10\text{ }\mu\text{s}$, $V_{bat} = 3.4\text{ V}$ $T_j = 25\text{ }^\circ\text{C}$ (Section 5.2) $C_{out} = 2.2\text{ }\mu\text{F}$, $\text{ESR} = 5\text{ m}\Omega$	-	9	-	mV	
PSRR	Power supply rejection ratio	$V_{bat} = 3.4\text{ V}$, $I_{out} = 100\text{ mA}$, $T_j = 25\text{ }^\circ\text{C}$, $C_{out} = 2.2\text{ }\mu\text{F}$, $\text{ESR} = 5\text{ m}\Omega$	F = 1 kHz	-	45	-	dB
			F = 10 kHz	-	35	-	dB
t_{start}	Settling time	$V_{out} \uparrow 95\%$ Nom, $V_{bat} = 5\text{ V}$, $I_{out} = 200\text{ mA}$ $T_j = -30\text{ }^\circ\text{C}$ to $125\text{ }^\circ\text{C}$, $C_{out} = 2.2\text{ }\mu\text{F}$, Enable L \rightarrow H	-	30	200	μs	
t_{stop}	Discharge time	$V_{out} \downarrow 10\%$ Nom, $V_{bat} = 3.4\text{ V}$, $I_{out} = 1\text{ mA}$ $T_j = 25\text{ }^\circ\text{C}$, $C_{out} = 2.2\text{ }\mu\text{F}$, Enable H \rightarrow L	-	600	-	μs	

5.1 Line regulation and transient line regulation

The line regulation (LiR) is a static variable that indicates the change in the output voltage of the voltage controller ΔV_{out} (at constant load) when there is a change ΔV_{bat} at the input voltage. By contrast the line transient response (LiTr) represents dynamic peak value to be observed during the change in input voltage

Thermal effects due to changes in the junction temperature are circumvented with pulsed voltage during the test and are to be taken into account separately.

The figure shows the boundary conditions for t_{rise} , t_{fall} , and ΔV_{bat} to be taken as the basis of the measurement of the line transient response without additional decoupling of the supply voltage by a buffer capacity C_{bat} . The values defined in the specification apply, however, only in the case of decoupling of the supply voltage with such a capacity C_{bat} , as a result of which the values for t_{rise} and t_{fall} are influenced to some extent.

Figure 13. Line regulation and transient line regulation

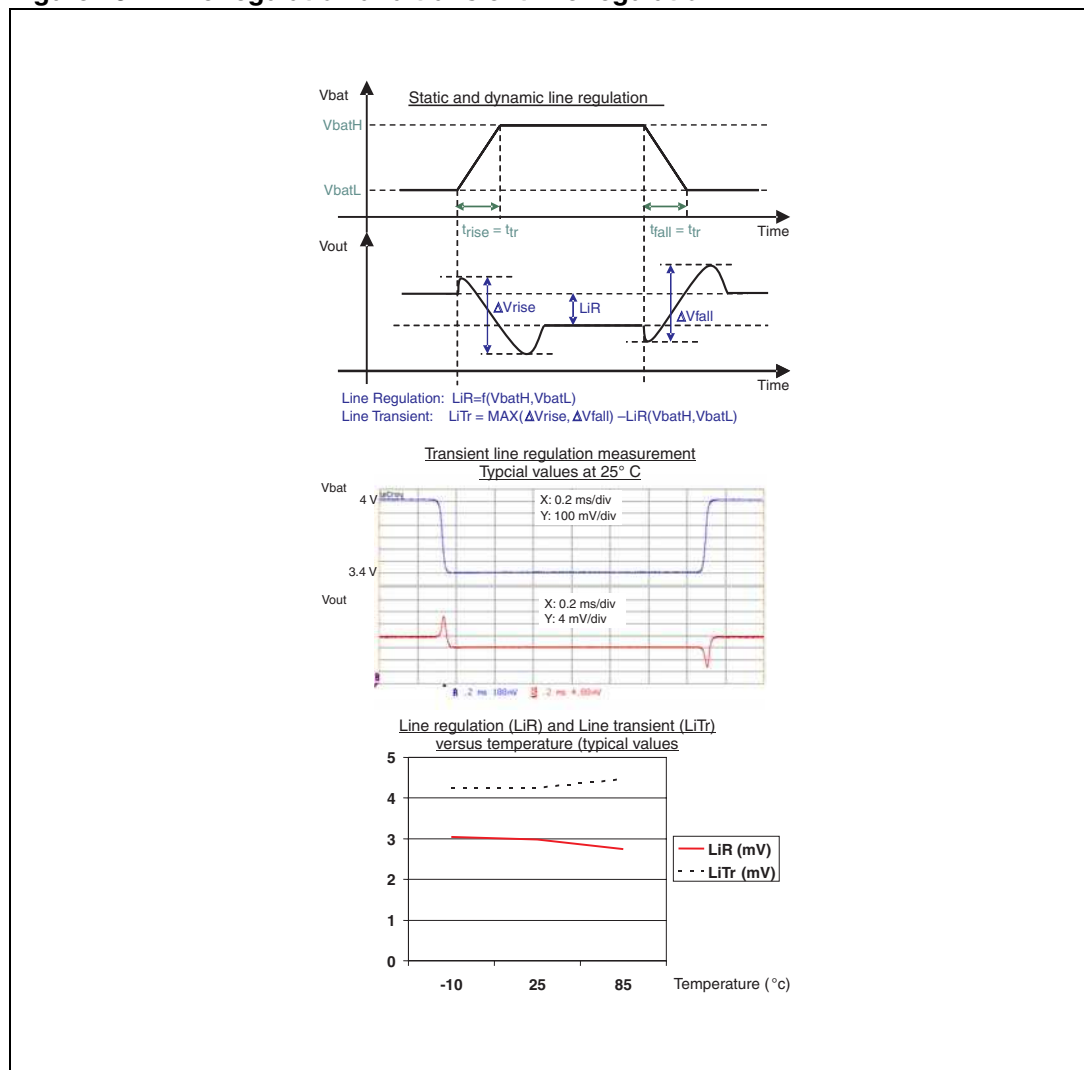

5.2 Load regulation and transient load regulation

The load regulation (LdR) is a static variable that indicates the change in output voltage of the voltage controller ΔV_{out} (at constant input voltage) in the event of a change in the load current ΔI_{out} . By contrast the load transient response (LdTr) represents the dynamic peak value to be observed during load variation.

Thermal effects due to changes in the junction temperature are circumvented by testing with pulsed load and are to be taken into account separately.

The figure shows the boundary conditions for t_{rise} , t_{fall} , and ΔI_{out} to be taken as the basis for the measurement of the load transient response.

Figure 14. Load regulation and transient load regulation

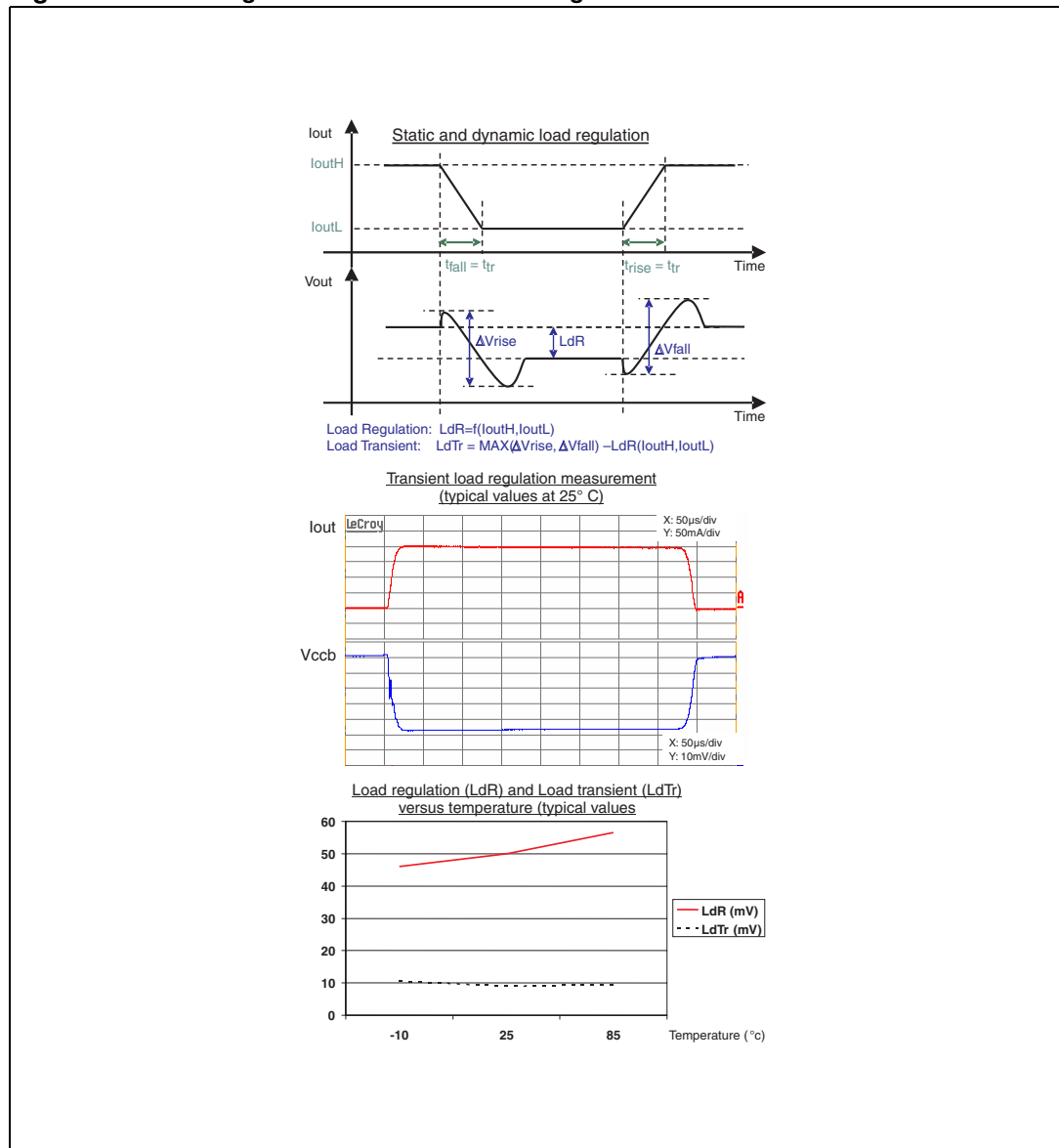

5.3 Dropout definition

The dropout voltage (V_{DO}) is measured by decreasing the input voltage till the output voltage will drop by 100 mV compared to the output voltage measured at the specified minimum supply voltage (3.1 V).

Worst case for dropout is maximum die temperature and maximum current load. This is done statically.

Figure 15. Dropout definition

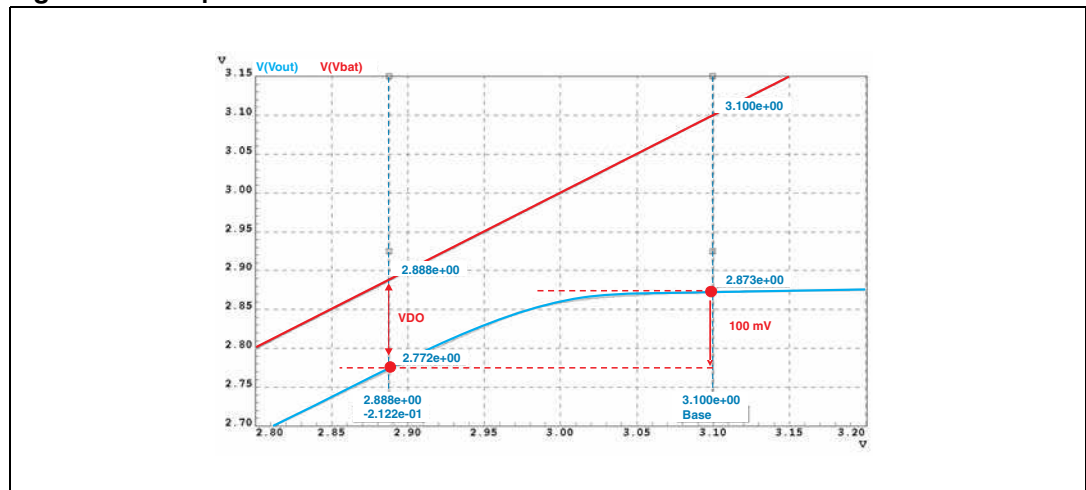

6 Application schematic

Figure 16. Application schematic

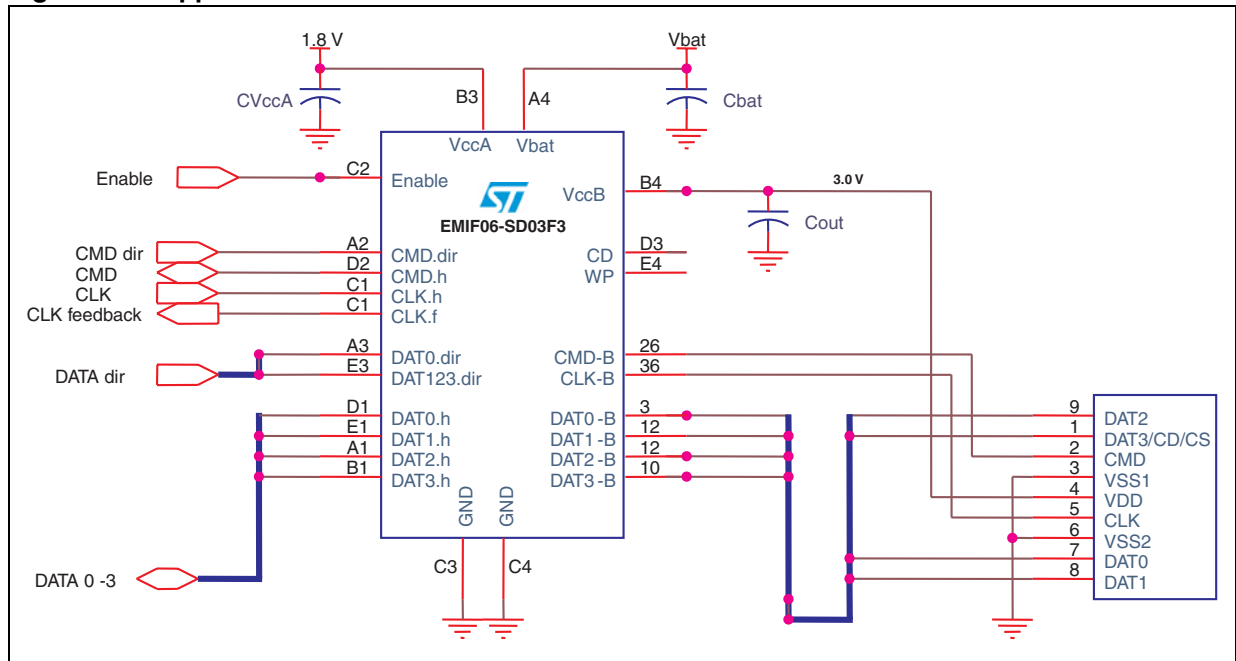

7 Ordering information scheme

Figure 17. Ordering information scheme

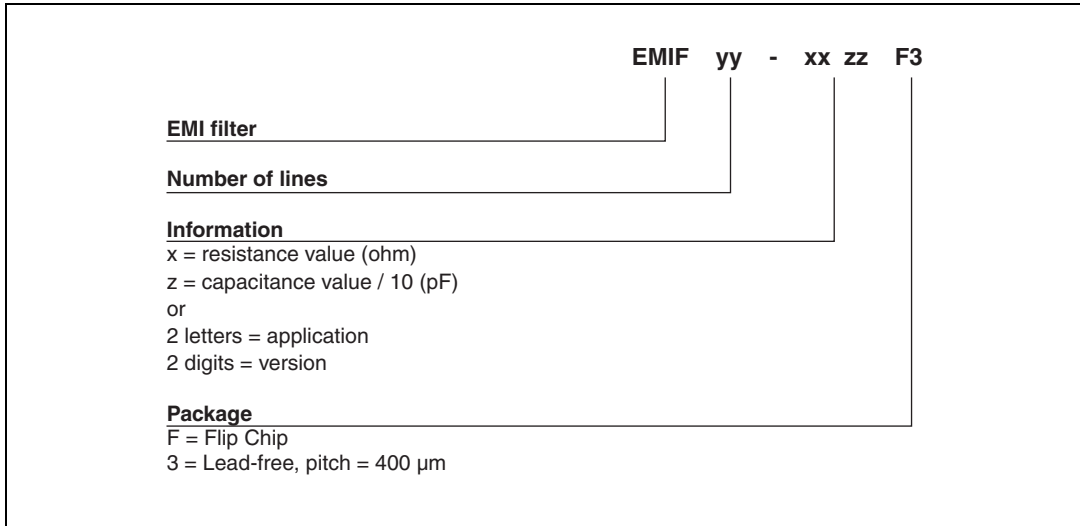

8 Package information

In order to meet environmental requirements, ST offers these devices in different grades of ECOPACK® packages, depending on their level of environmental compliance. ECOPACK® specifications, grade definitions and product status are available at: www.st.com. ECOPACK® is an ST trademark.

Figure 18. Flip Chip dimensions

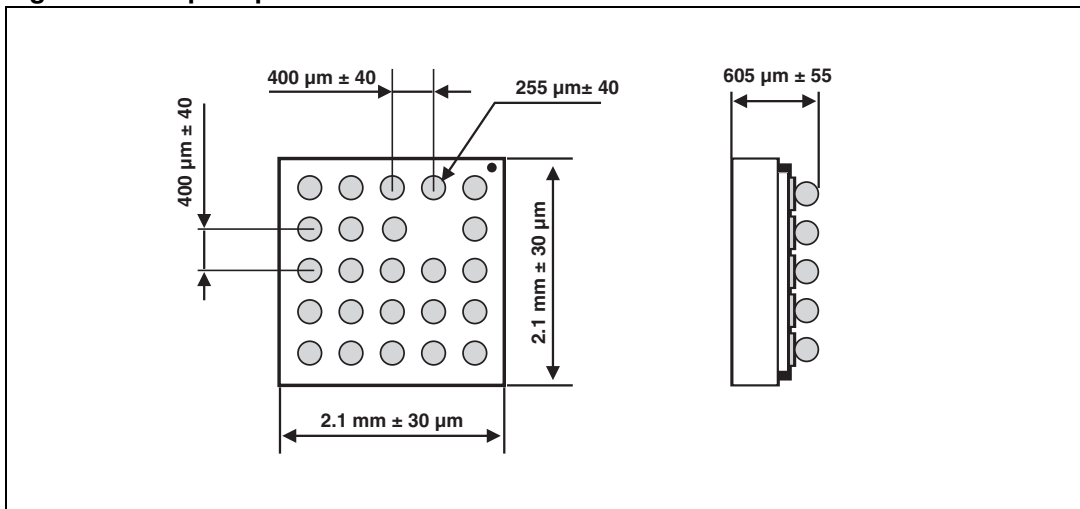

Figure 19. Footprint recommendations

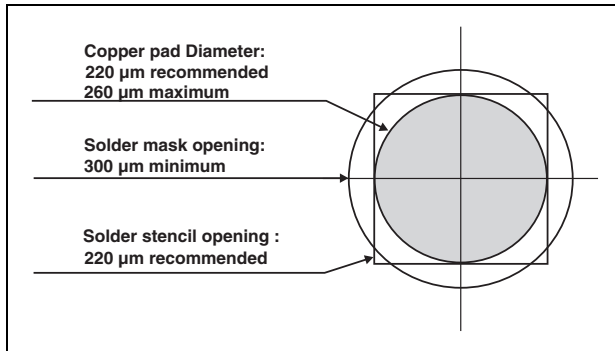

Figure 20. Marking

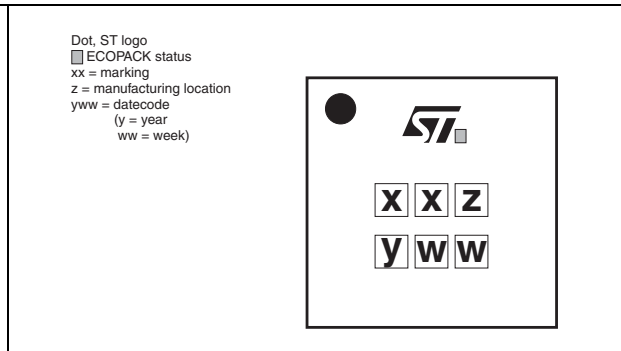
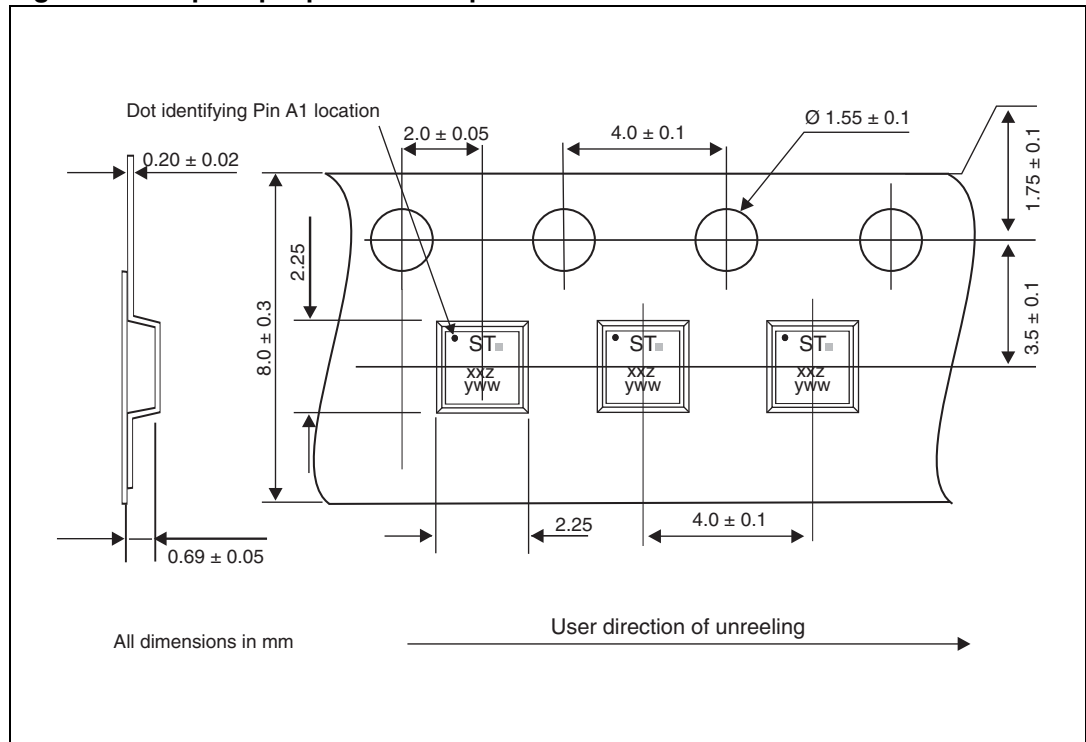

Figure 21. Flip Chip tape and reel specifications



9 Ordering information

Table 14. Ordering information

Order code	Marking	Package	Weight	Base qty	Delivery mode
EMIF06-SD03F3	HY	Flip Chip	5.46 mg	5000	Tape and reel (7")

Note: More information is available in the application notes:
 AN2348 : "Flip Chip : Package description and recommendations for use"
 AN1751 : EMI Filters: Recommendations and measurements

10 Revision history

Table 15. Document revision history

Date	Revision	Changes
21-Nov-2008	1	First issue
11-Feb-2010	2	AC timing characteristics updated in Table 11 .

Please Read Carefully:

Information in this document is provided solely in connection with ST products. STMicroelectronics NV and its subsidiaries ("ST") reserve the right to make changes, corrections, modifications or improvements, to this document, and the products and services described herein at any time, without notice.

All ST products are sold pursuant to ST's terms and conditions of sale.

Purchasers are solely responsible for the choice, selection and use of the ST products and services described herein, and ST assumes no liability whatsoever relating to the choice, selection or use of the ST products and services described herein.

No license, express or implied, by estoppel or otherwise, to any intellectual property rights is granted under this document. If any part of this document refers to any third party products or services it shall not be deemed a license grant by ST for the use of such third party products or services, or any intellectual property contained therein or considered as a warranty covering the use in any manner whatsoever of such third party products or services or any intellectual property contained therein.

UNLESS OTHERWISE SET FORTH IN ST'S TERMS AND CONDITIONS OF SALE ST DISCLAIMS ANY EXPRESS OR IMPLIED WARRANTY WITH RESPECT TO THE USE AND/OR SALE OF ST PRODUCTS INCLUDING WITHOUT LIMITATION IMPLIED WARRANTIES OF MERCHANTABILITY, FITNESS FOR A PARTICULAR PURPOSE (AND THEIR EQUIVALENTS UNDER THE LAWS OF ANY JURISDICTION), OR INFRINGEMENT OF ANY PATENT, COPYRIGHT OR OTHER INTELLECTUAL PROPERTY RIGHT.

UNLESS EXPRESSLY APPROVED IN WRITING BY AN AUTHORIZED ST REPRESENTATIVE, ST PRODUCTS ARE NOT RECOMMENDED, AUTHORIZED OR WARRANTED FOR USE IN MILITARY, AIR CRAFT, SPACE, LIFE SAVING, OR LIFE SUSTAINING APPLICATIONS, NOR IN PRODUCTS OR SYSTEMS WHERE FAILURE OR MALFUNCTION MAY RESULT IN PERSONAL INJURY, DEATH, OR SEVERE PROPERTY OR ENVIRONMENTAL DAMAGE. ST PRODUCTS WHICH ARE NOT SPECIFIED AS "AUTOMOTIVE GRADE" MAY ONLY BE USED IN AUTOMOTIVE APPLICATIONS AT USER'S OWN RISK.

Resale of ST products with provisions different from the statements and/or technical features set forth in this document shall immediately void any warranty granted by ST for the ST product or service described herein and shall not create or extend in any manner whatsoever, any liability of ST.

ST and the ST logo are trademarks or registered trademarks of ST in various countries.

Information in this document supersedes and replaces all information previously supplied.

The ST logo is a registered trademark of STMicroelectronics. All other names are the property of their respective owners.

© 2010 STMicroelectronics - All rights reserved

STMicroelectronics group of companies

Australia - Belgium - Brazil - Canada - China - Czech Republic - Finland - France - Germany - Hong Kong - India - Israel - Italy - Japan - Malaysia - Malta - Morocco - Philippines - Singapore - Spain - Sweden - Switzerland - United Kingdom - United States of America

www.st.com