

2-channel EMI filter and ESD protection for speaker phone

Datasheet – production data

Features

- 2-channel EMI symmetrical (I/O) low-pass filter
- High efficiency in EMI filtering:
 - S21 attenuation, -40 dB at 900 MHz
 - Xtalk, in audio band, -60 dB
- Very low PCB space consumption: 0.89 x 1.26 mm
- Very thin package: 0.6 mm after reflow
- High efficiency in ESD suppression on input pins (IEC 61000-4-2 level 4)
- High reliability offered by monolithic integration
- High reduction of parasitic elements through integration and wafer level packaging
- Packaged in lead-free Flip Chip

Complies with the following standards

- IEC 61000-4-2 level 4:
 - ±15 kV (air discharge)
 - ±8 kV (contact discharge)

Application

- Mobile phones
- Portable devices
- Connectivity devices

Description

The EMIF02-SPK03F2 chip is a highly integrated device designed to suppress EMI/RFI noise for interface line filtering.

The EMIF02-SPK03F2 is 2-channel, ultra compact, high attenuation filter available in 0.5 mm pitch WLCSP package. Additionally, this filter includes ESD protection circuitry, which prevents damage to the protected device when subjected to ESD surges up to 30 kV.

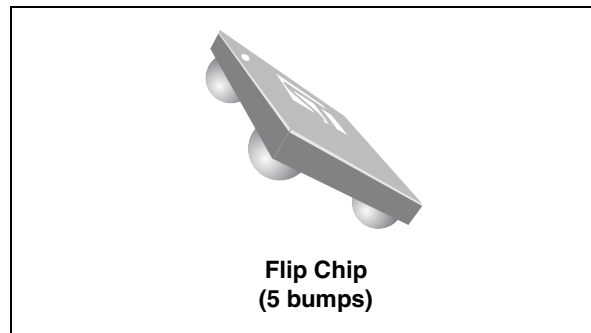

Figure 1. Pin configuration (bump side)

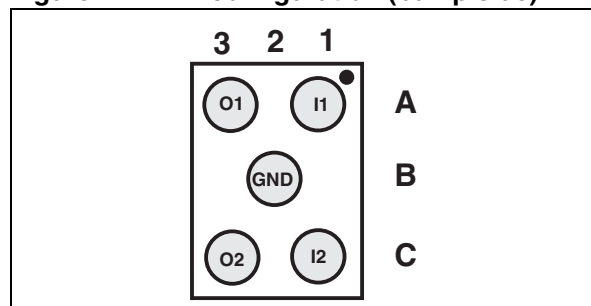
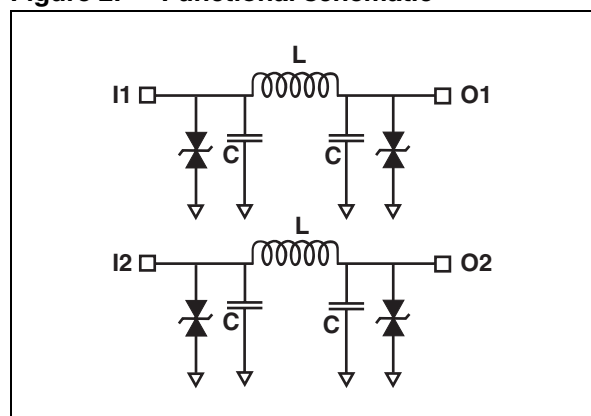

Figure 2. Functional schematic



1 Characteristics

Table 1. Absolute maximum ratings ($T_{amb} = 25\text{ }^{\circ}\text{C}$)

Symbol	Parameter	Value	Unit
V_{PP}	ESD discharge IEC 61000-4-2 ⁽¹⁾ Air discharge Contact discharge	30	kV
I_{SPK}	Maximum rms current per channel	800	mA
T_j	Maximum junction temperature	125	$^{\circ}\text{C}$
T_{op}	Operating temperature range	-30 to 85	$^{\circ}\text{C}$
T_{stg}	Storage temperature range	-55 to + 150	$^{\circ}\text{C}$

1. Measurements done on IEC 61000-4-2 test bench. For further details see Application note AN3353, "IEC 61000-4-2 standard testing".

Figure 3. Electrical characteristics - definitions

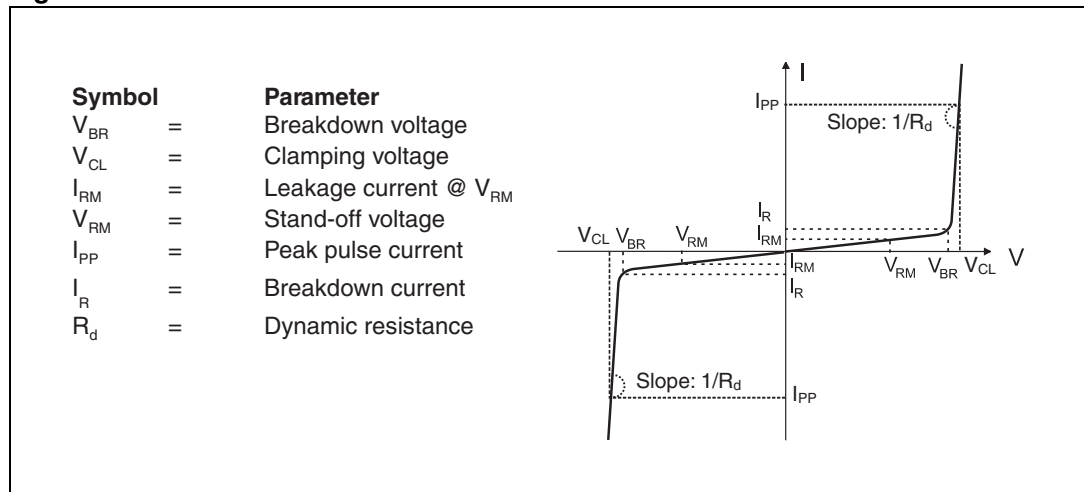

Table 2. Electrical characteristics - values ($T_{amb} = 25\text{ }^{\circ}\text{C}$)

Symbol	Test conditions	Min.	Typ.	Max.	Unit
V_{BR}	$I_R = 1\text{ mA}$	6			V
R_d	$t_p = 100\text{ ns}$		0.2		Ω
I_{RM}	$V_{RM} = 3\text{ V per line}$			0.3	μA
R_{DC_L}	DC resistance of the inductor		0.07	0.1	Ω
C_{line}	$V_{line} = 0\text{ V}, V_{OSC} = 30\text{ mV}, F = 1\text{ MHz}$		250		pF

Figure 4. Insertion losses versus frequency

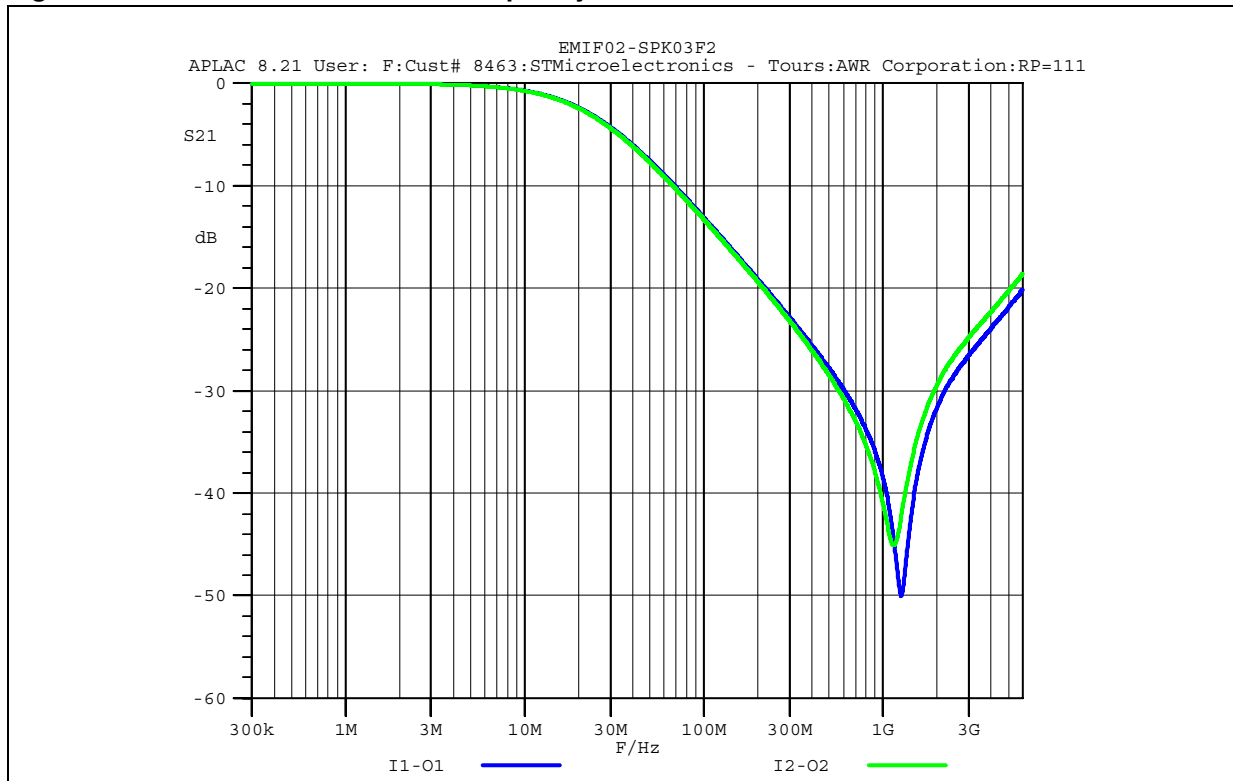

Figure 5. Analog crosstalk versus frequency

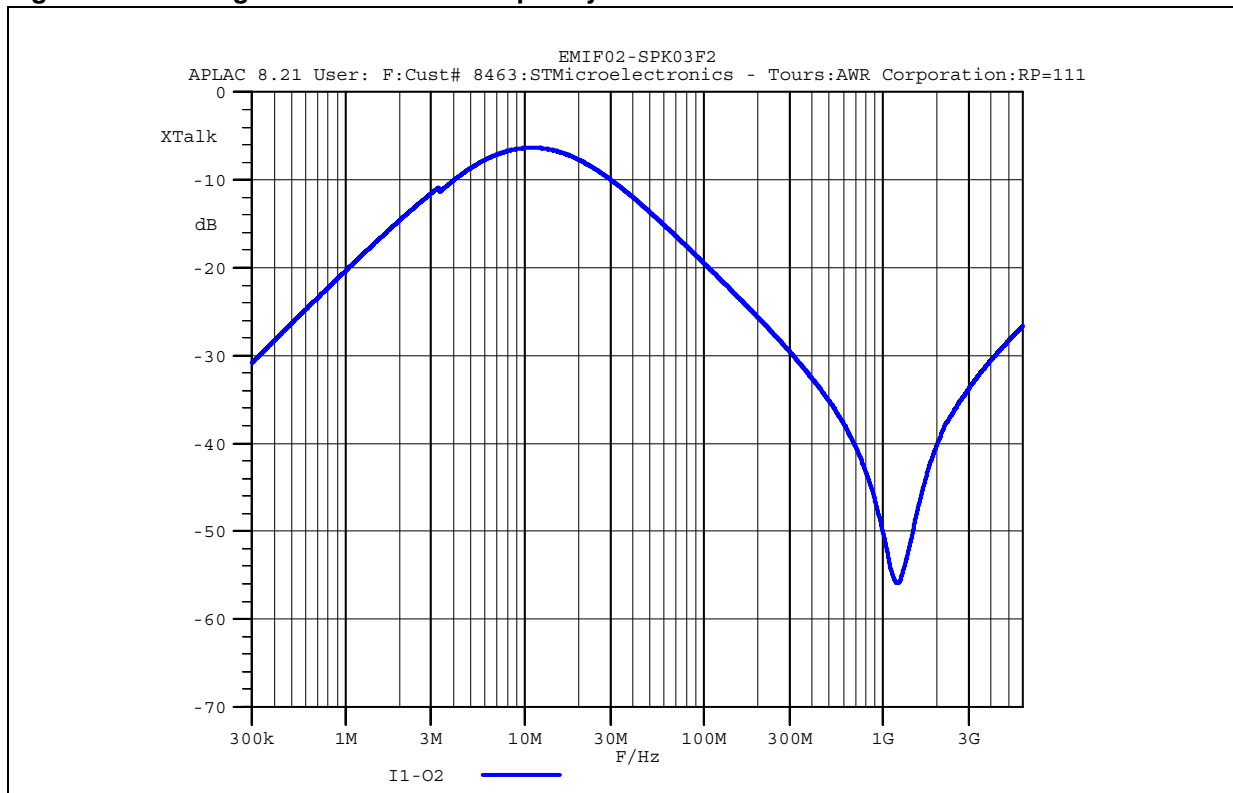
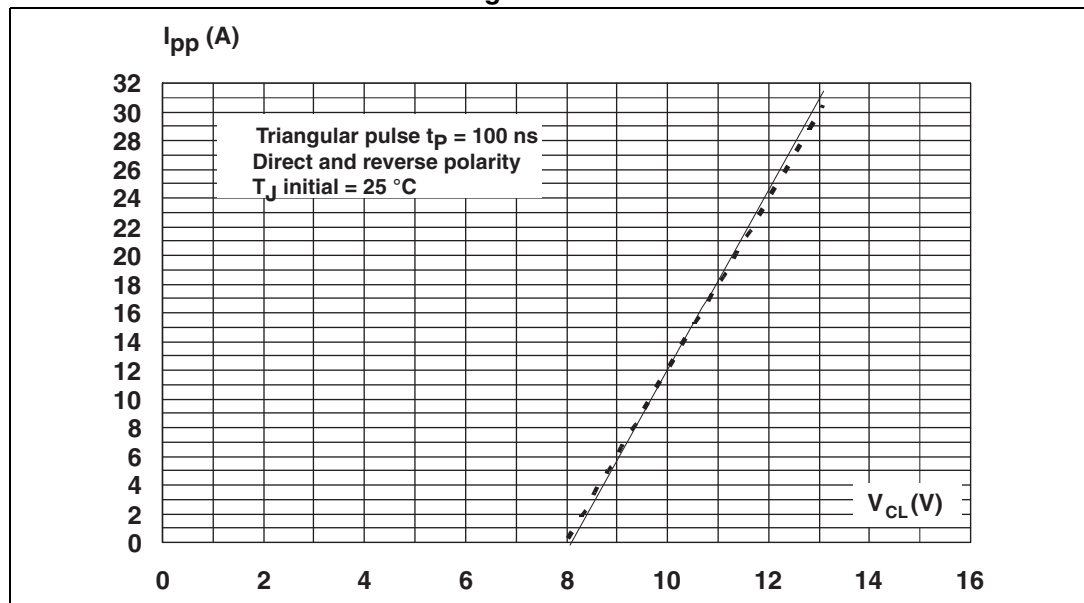

Figure 6. Audio band analog crosstalk



Figure 7. Clamping voltage V_{CL} versus peak pulse current I_{PP} for short pulse duration such as ESD surges



Note: For further information on the dynamic characteristic see the STMicroelectronics' application note AN4022, "TVS short pulse R_D measurement and correlation with TVS clamping voltage during ESD".

Figure 8. ESD test conditions

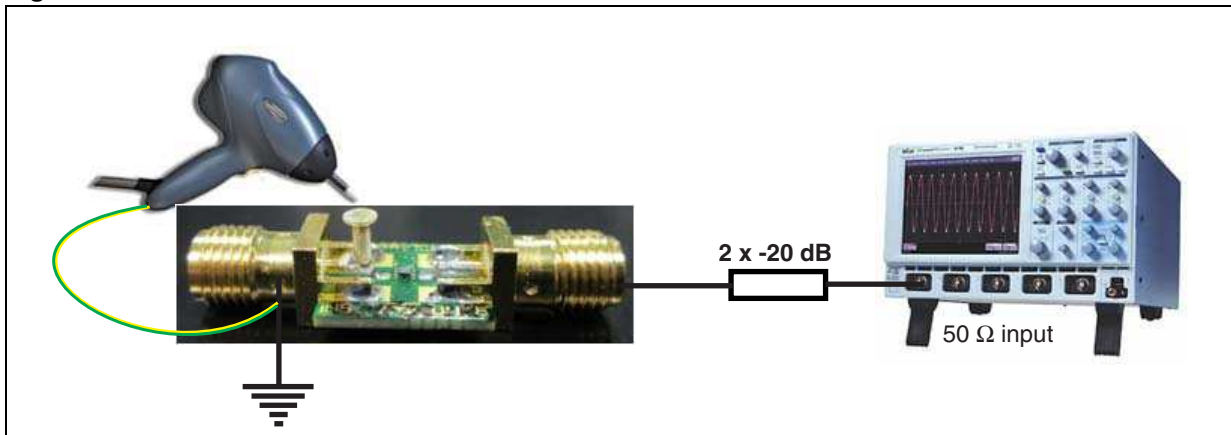

Figure 9. Output filter ESD response to IEC 61000-4-2 (+30 kV contact discharge) Ix to Ox

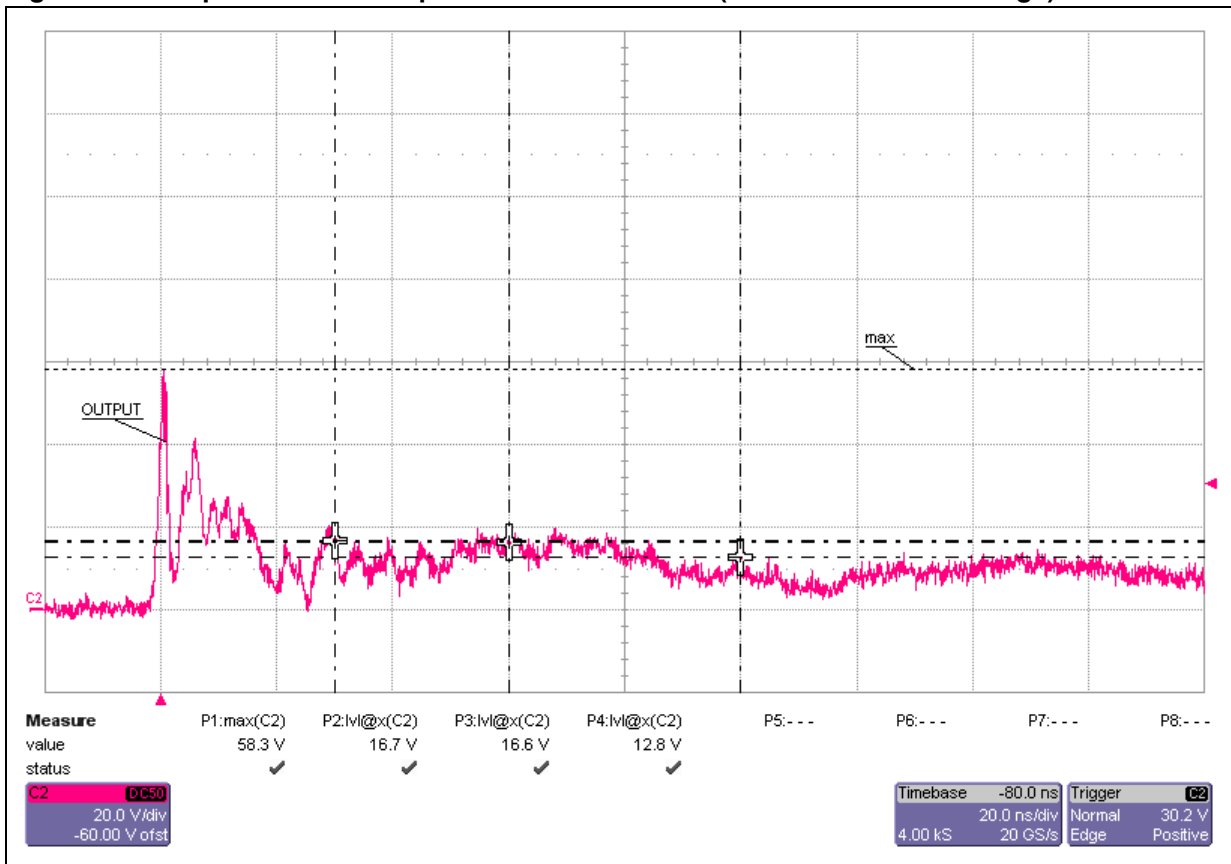

Figure 10. Output filter ESD response to IEC 61000-4-2 (-30 kV contact discharge) Ix to Ox

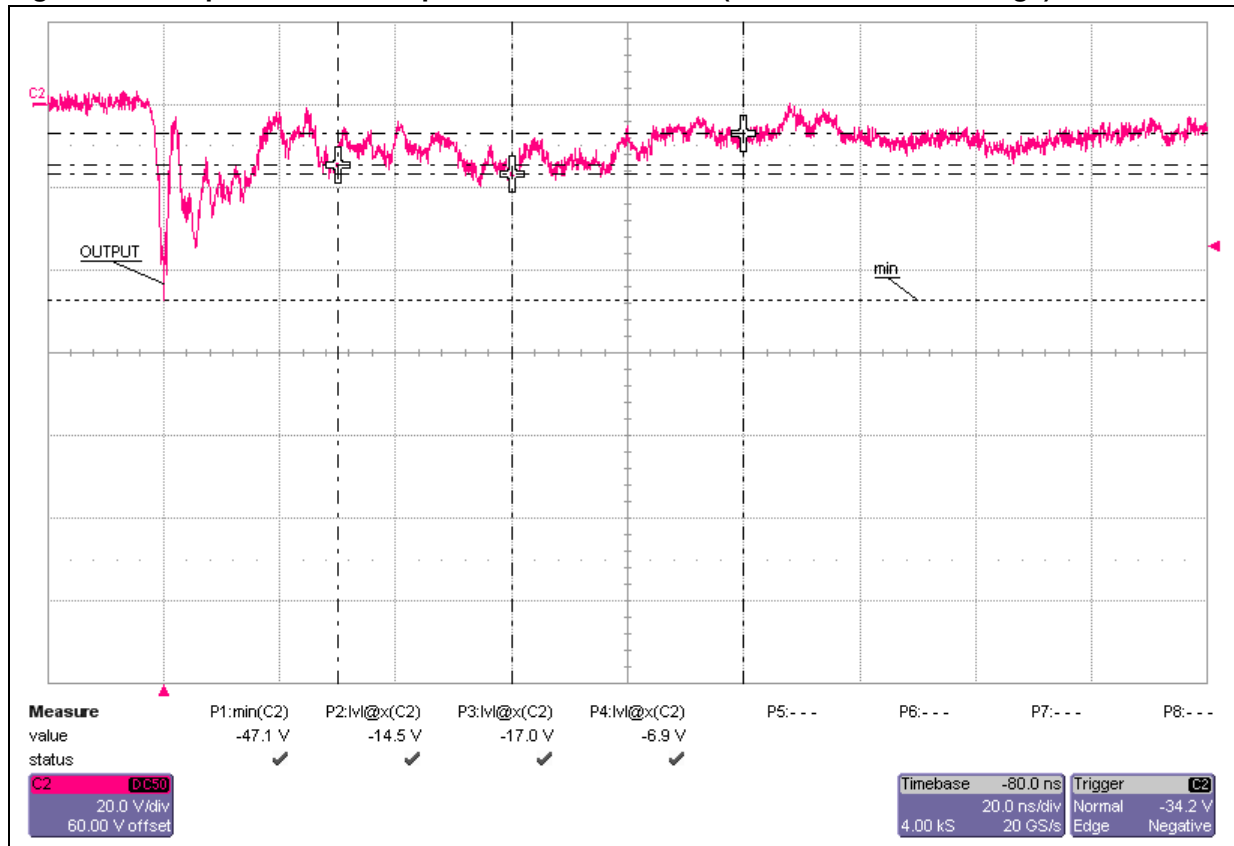
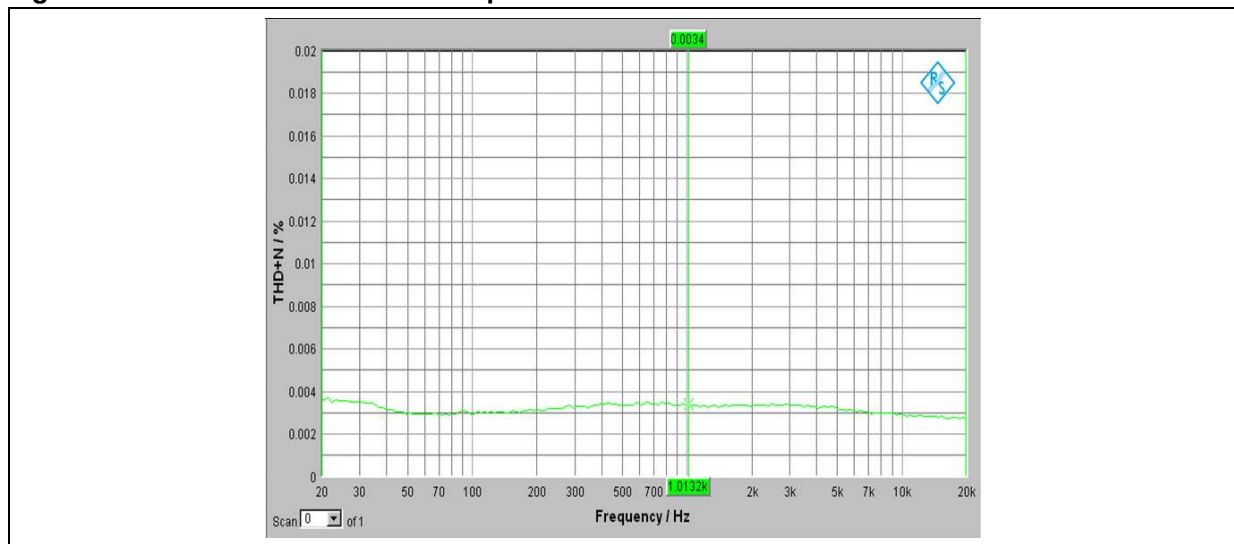
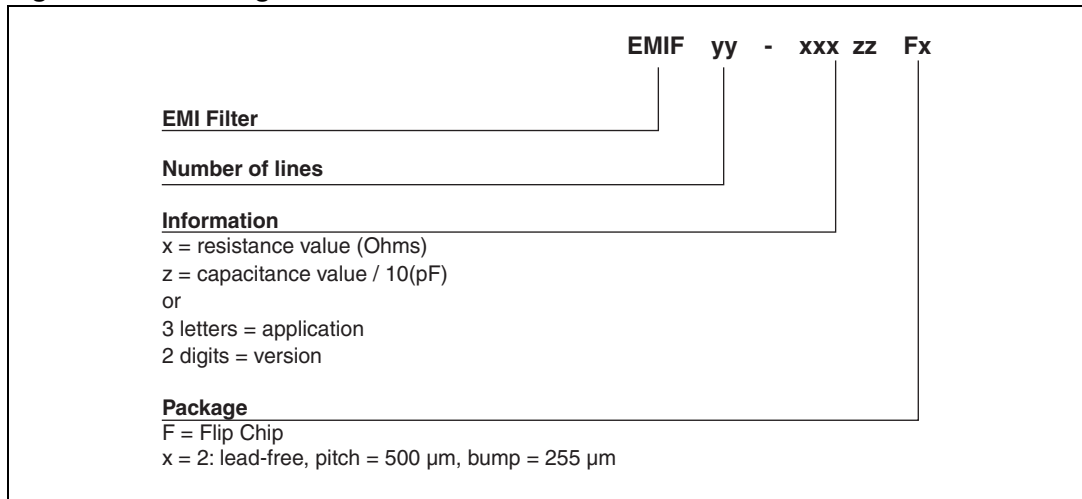

Figure 11. Total harmonic distortion plus noise



2 Ordering information scheme

Figure 12. Ordering information scheme



3 Package information

In order to meet environmental requirements, ST offers these devices in different grades of ECOPACK® packages, depending on their level of environmental compliance. ECOPACK® specifications, grade definitions and product status are available at: www.st.com. ECOPACK® is an ST trademark.

Figure 13. Package dimensions

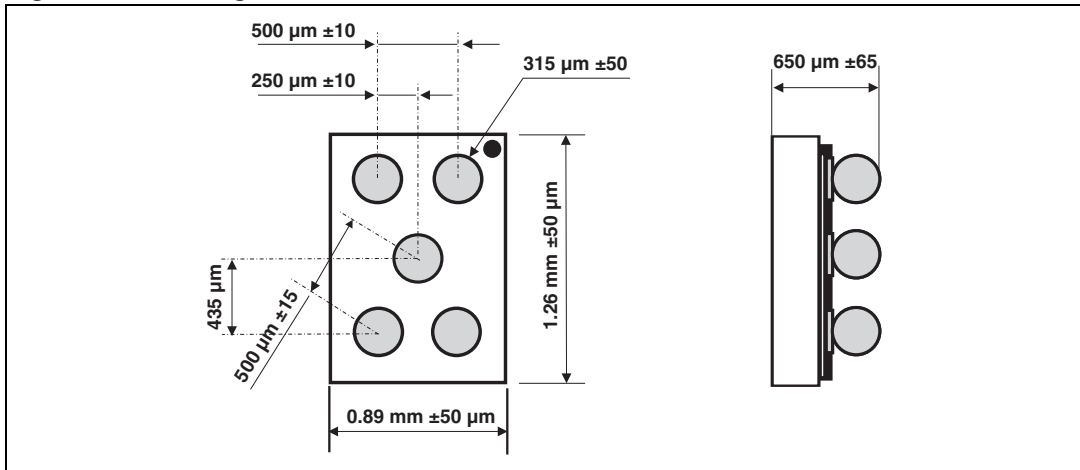

Figure 14. Footprint

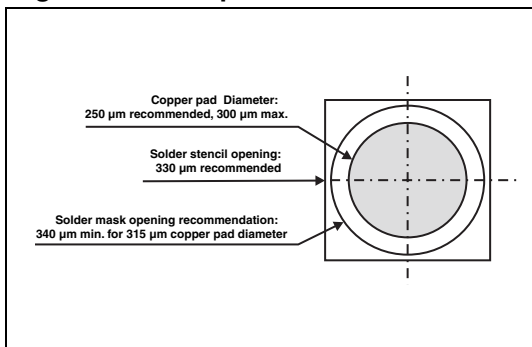

Figure 15. Marking

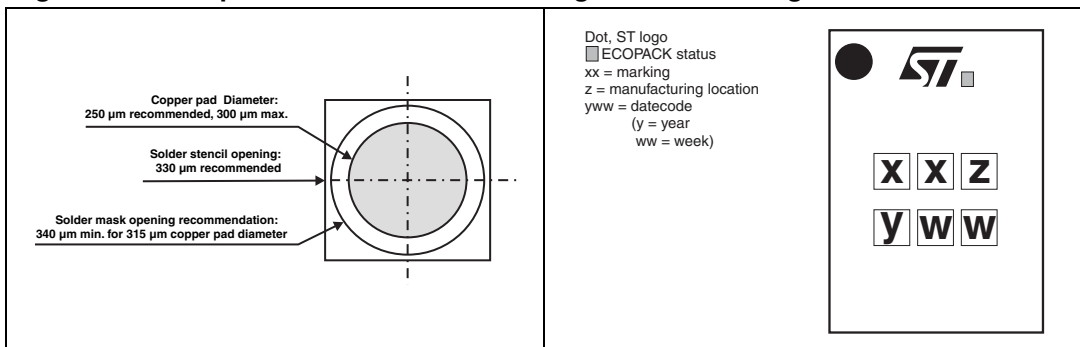
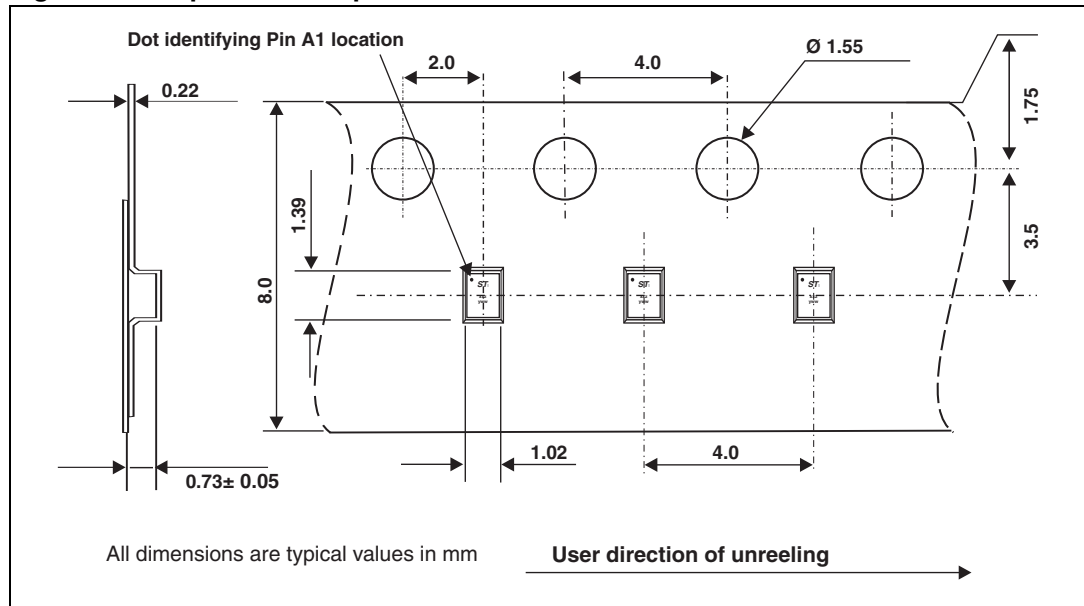

Figure 16. Tape and reel specification



Note: More information is available in the application notes:
 AN1235, "IPAD™ 400 μm Flip Chip: package description and recommendations for use"
 AN1751, "EMI filters: recommendations and measurements"

4 Ordering information

Table 3. Ordering information

Order code	Marking	Package	Weight	Base qty	Delivery mode
EMIF02-SPK03F2	JX	Flip Chip	1.8 mg	5000	Tape and reel 7"

5 Revision history

Table 4. Document revision history

Date	Revision	Changes
19-Jun-2012	1	Initial release.

Please Read Carefully:

Information in this document is provided solely in connection with ST products. STMicroelectronics NV and its subsidiaries ("ST") reserve the right to make changes, corrections, modifications or improvements, to this document, and the products and services described herein at any time, without notice.

All ST products are sold pursuant to ST's terms and conditions of sale.

Purchasers are solely responsible for the choice, selection and use of the ST products and services described herein, and ST assumes no liability whatsoever relating to the choice, selection or use of the ST products and services described herein.

No license, express or implied, by estoppel or otherwise, to any intellectual property rights is granted under this document. If any part of this document refers to any third party products or services it shall not be deemed a license grant by ST for the use of such third party products or services, or any intellectual property contained therein or considered as a warranty covering the use in any manner whatsoever of such third party products or services or any intellectual property contained therein.

UNLESS OTHERWISE SET FORTH IN ST'S TERMS AND CONDITIONS OF SALE ST DISCLAIMS ANY EXPRESS OR IMPLIED WARRANTY WITH RESPECT TO THE USE AND/OR SALE OF ST PRODUCTS INCLUDING WITHOUT LIMITATION IMPLIED WARRANTIES OF MERCHANTABILITY, FITNESS FOR A PARTICULAR PURPOSE (AND THEIR EQUIVALENTS UNDER THE LAWS OF ANY JURISDICTION), OR INFRINGEMENT OF ANY PATENT, COPYRIGHT OR OTHER INTELLECTUAL PROPERTY RIGHT.

UNLESS EXPRESSLY APPROVED IN WRITING BY TWO AUTHORIZED ST REPRESENTATIVES, ST PRODUCTS ARE NOT RECOMMENDED, AUTHORIZED OR WARRANTED FOR USE IN MILITARY, AIR CRAFT, SPACE, LIFE SAVING, OR LIFE SUSTAINING APPLICATIONS, NOR IN PRODUCTS OR SYSTEMS WHERE FAILURE OR MALFUNCTION MAY RESULT IN PERSONAL INJURY, DEATH, OR SEVERE PROPERTY OR ENVIRONMENTAL DAMAGE. ST PRODUCTS WHICH ARE NOT SPECIFIED AS "AUTOMOTIVE GRADE" MAY ONLY BE USED IN AUTOMOTIVE APPLICATIONS AT USER'S OWN RISK.

Resale of ST products with provisions different from the statements and/or technical features set forth in this document shall immediately void any warranty granted by ST for the ST product or service described herein and shall not create or extend in any manner whatsoever, any liability of ST.

ST and the ST logo are trademarks or registered trademarks of ST in various countries.

Information in this document supersedes and replaces all information previously supplied.

The ST logo is a registered trademark of STMicroelectronics. All other names are the property of their respective owners.

© 2012 STMicroelectronics - All rights reserved

STMicroelectronics group of companies

Australia - Belgium - Brazil - Canada - China - Czech Republic - Finland - France - Germany - Hong Kong - India - Israel - Italy - Japan - Malaysia - Malta - Morocco - Philippines - Singapore - Spain - Sweden - Switzerland - United Kingdom - United States of America

www.st.com