



TS331, TS332, TS334

Micropower low-voltage rail-to-rail comparators

Features

- Supply operation from 1.6 to 5 V
- Low current consumption: 20 μ A
- Rail-to-rail inputs
- Wide temperature range: -40°C to +125°C
- Low output saturation voltage
- Low propagation delay: 210 ns
- Open-drain output
- ESD tolerance: 2 kV HBM/200 V MM
- SMD packages

Applications

- Mobile phones
- Notebooks and PDAs
- Battery supplied electronics
- General-purpose portable devices
- General-purpose low voltage applications

Description

The TS331, TS332 and TS334 are single, dual and quad micropower and low-voltage comparators. They can operate with a supply voltage ranging from 1.6 to 5 V with a typical current consumption as low as 20 μ A. In addition, rail-to-rail inputs make them a perfect choice for low-voltage applications.

Their availability in tiny packages is a real advantage for space saving constraints.

The TS33x are specified for a wide temperature range of -40°C to +125°C, making them ideal for a wide range of applications.

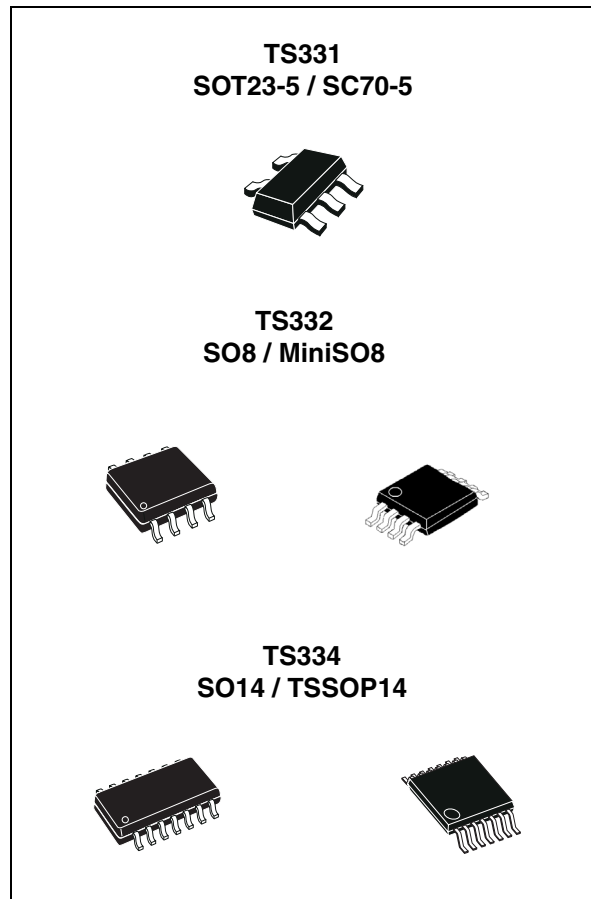

1 Package pin connections

Figure 1. Pin connections for each package (top view)

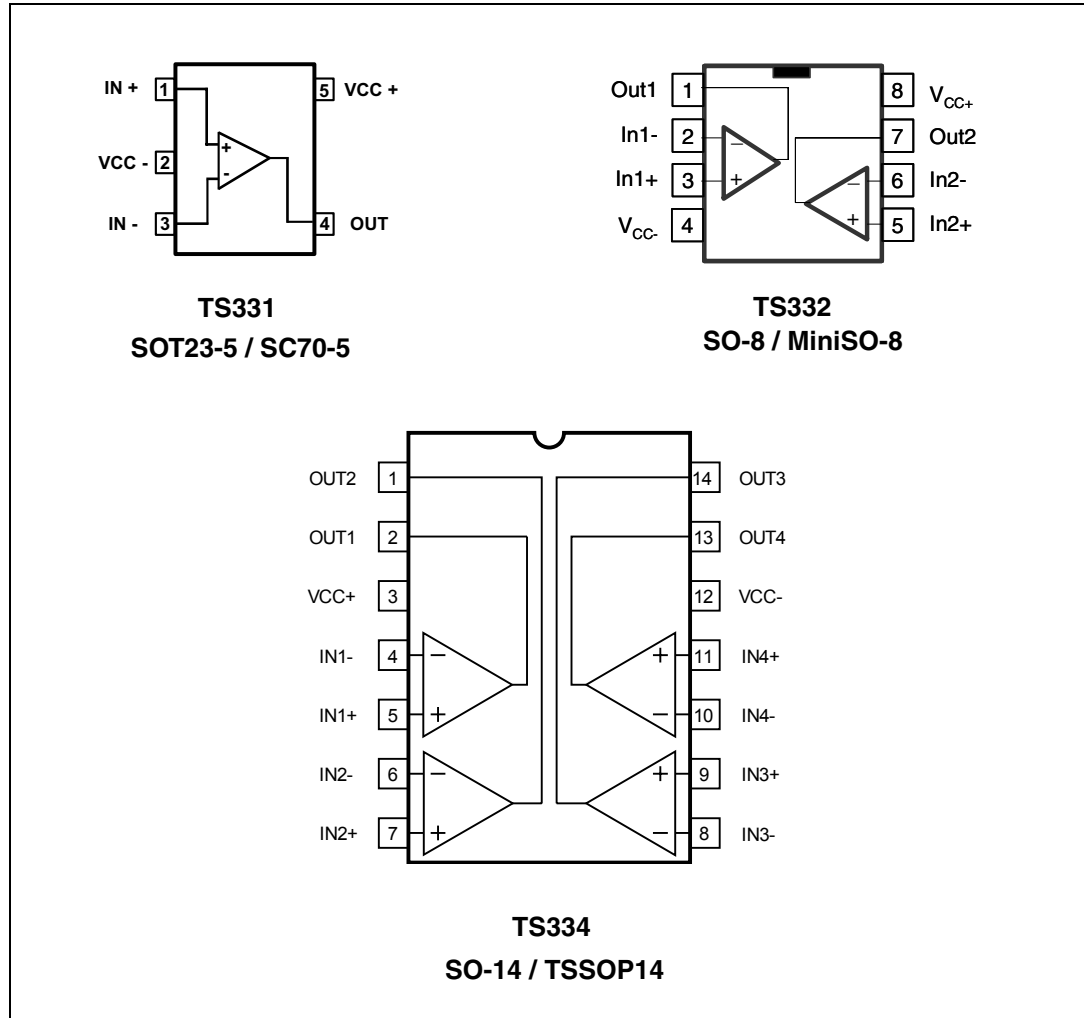

2 Absolute maximum ratings and operating conditions

Table 1. Absolute maximum ratings

Symbol	Parameter	Value	Unit
V_{CC}	Supply voltage ⁽¹⁾	5.5	V
V_{ID}	Differential input voltage	± 5.5	V
V_{IN}	Input voltage range	$(V_{CC-}) - 0.3$ to $(V_{CC+}) + 0.3$	V
V_{out}	Output voltage ⁽¹⁾	5.5	V
R_{thja}	Thermal resistance junction to ambient ⁽²⁾		°C/W
	SC70-5	205	
	SOT23-5	250	
	SO8	125	
	MiniSO8	190	
	SO14 TSSOP14	105 100	
R_{thjc}	Thermal resistance junction to case ⁽²⁾		°C/W
	SC70-5	172	
	SOT23-5	81	
	SO8	40	
	MiniSO8	39	
	SO14 TSSOP14	31 32	
T_{stg}	Storage temperature	-65 to +150	°C
T_j	Junction temperature	150	°C
T_{LEAD}	Lead temperature (soldering 10 seconds)	260	°C
ESD	Human body model (HBM) ⁽³⁾	2000	V
	Machine model (MM) ⁽⁴⁾	200	
	Charged device model (CDM) ⁽⁵⁾	1500	
	Latch-up immunity	200	mA

1. All voltage values, except differential voltage, are referenced to V_{CC-} .
2. Short-circuits can cause excessive heating. These values are typical.
3. Human body model: a 100 pF capacitor is charged to the specified voltage, then discharged through a 1.5 kΩ resistor between two pins of the device. This is done for all couples of connected pin combinations while the other pins are floating.
4. Machine model: a 200 pF capacitor is charged to the specified voltage, then discharged directly between two pins of the device with no external series resistor (internal resistor < 5 Ω). This is done for all couples of connected pin combinations while the other pins are floating.
5. Charged device model: all pins and package are charged together to the specified voltage and then discharged directly to ground through only one pin. This is done for all pins.

Table 2. Operating conditions

Symbol	Parameter	Value	Unit
T_{oper}	Operating temperature range	-40 to +125	°C
V_{CC}	Supply voltage (V_{CC+}) - (V_{CC-}) $-40^{\circ}\text{C} < T_{amb} < +125^{\circ}\text{C}$	1.6 to 5.0	V
V_{ICM}	Common mode input voltage range $T_{amb} = +25^{\circ}\text{C}$ $-40^{\circ}\text{C} < T_{amb} < +125^{\circ}\text{C}$	$(V_{CC-}) - 0.2$ to $(V_{CC+}) + 0.2$ (V_{CC-}) to (V_{CC+})	V

3 Electrical characteristics

Table 3. $V_{CC+} = +1.8\text{ V}$, $V_{CC-} = 0\text{ V}$, $T_{amb} = +25^{\circ}\text{C}$ (unless otherwise specified)

Symbol	Parameter	Test conditions	Min.	Typ.	Max.	Unit
V_{IO}	Input offset voltage	$-40^{\circ}\text{C} < T_{amb} < +125^{\circ}\text{C}$		0.5	5 6	mV
ΔV_{IO}	Input offset voltage drift	$-40^{\circ}\text{C} < T_{amb} < +125^{\circ}\text{C}$		4.5		$\mu\text{V}/^{\circ}\text{C}$
I_{IB}	Input bias current ⁽¹⁾	$-40^{\circ}\text{C} < T_{amb} < +125^{\circ}\text{C}$		25	40 100	nA
I_{IO}	Input offset current ⁽¹⁾	$-40^{\circ}\text{C} < T_{amb} < +125^{\circ}\text{C}$		1	10 100	nA
I_{CC}	Supply current	No load, output low, $V_{ICM} = 0\text{ V}$ $-40^{\circ}\text{C} < T_{amb} < +125^{\circ}\text{C}$		20	26 30	μA
		No load, output high, $V_{ICM} = 0\text{ V}$ $-40^{\circ}\text{C} < T_{amb} < +125^{\circ}\text{C}$		22	29 33	
I_{OH}	Output current leakage	$V_{OUT} = V_{CC+}$ $-40^{\circ}\text{C} < T_{amb} < +125^{\circ}\text{C}$		1	10 500	nA
V_{OL}	Output voltage low	$I_{SINK} = 1\text{ mA}$ $-40^{\circ}\text{C} < T_{amb} < +125^{\circ}\text{C}$		24	30 50	mV
I_{SINK}	Output sink current	$V_{OUT} = 1.5\text{ V}$ $-40^{\circ}\text{C} < T_{amb} < +125^{\circ}\text{C}$	20 15	22		mA
CMRR	Common mode rejection ratio	$0 < V_{ICM} < 1.8\text{ V}$	50	68		dB
TP_{HL}	Propagation delay ⁽²⁾ High to low output level	$V_{ICM} = 0\text{ V}$, $R_L = 5.1\text{ k}\Omega$, $C_L = 50\text{ pF}$ Overdrive = 10 mV Overdrive = 100 mV		300 210	310	ns
TP_{LH}	Propagation delay ⁽³⁾ Low to high output level	$V_{ICM} = 0\text{ V}$, $R_L = 5.1\text{ k}\Omega$, $C_L = 50\text{ pF}$ Overdrive = 10 mV Overdrive = 100 mV		540 420	620	ns

1. Maximum values include unavoidable inaccuracies of the industrial tests.
2. TP_{HL} is measured when the output signal crosses a voltage level at 50% of V_{CC} with the following conditions: inverting input voltage (IN-) = V_{ICM} and non-inverting input voltage (IN+) moving from $V_{ICM} + 100\text{ mV}$ to $V_{ICM} - \text{overdrive}$.
3. TP_{LH} is measured when the output signal crosses a voltage level at 50% of V_{CC} with the following conditions: inverting input voltage (IN-) = V_{ICM} and non-inverting input voltage (IN+) moving from $V_{ICM} - 100\text{ mV}$ to $V_{ICM} + \text{overdrive}$.

Table 4. $V_{CC+} = +2.7\text{ V}$, $V_{CC-} = 0\text{ V}$, $T_{amb} = +25^\circ\text{C}$ (unless otherwise specified)

Symbol	Parameter	Test conditions	Min.	Typ.	Max.	Unit
V_{IO}	Input offset voltage	$-40^\circ\text{C} < T_{amb} < +125^\circ\text{C}$		0.5	5 6	mV
ΔV_{IO}	Input offset voltage drift	$-40^\circ\text{C} < T_{amb} < +125^\circ\text{C}$		3.3		$\mu\text{V}/^\circ\text{C}$
I_{IB}	Input bias current ⁽¹⁾	$-40^\circ\text{C} < T_{amb} < +125^\circ\text{C}$		25	40 100	nA
I_{IO}	Input offset current ⁽¹⁾	$-40^\circ\text{C} < T_{amb} < +125^\circ\text{C}$		1	10 100	nA
I_{CC}	Supply current	No load, output low, $V_{ICM} = 0\text{ V}$ $-40^\circ\text{C} < T_{amb} < +125^\circ\text{C}$		21	27 31	μA
		No load, output high, $V_{ICM} = 0\text{ V}$ $-40^\circ\text{C} < T_{amb} < +125^\circ\text{C}$		23	30 34	
I_{OH}	Output current leakage	$V_{OUT} = V_{CC+}$ $-40^\circ\text{C} < T_{amb} < +125^\circ\text{C}$		1	10 500	nA
V_{OL}	Output voltage low	$I_{SINK} = 1\text{ mA}$ $-40^\circ\text{C} < T_{amb} < +125^\circ\text{C}$		17	30 50	mV
I_{SINK}	Output sink current	$V_{OUT} = 1.5\text{ V}$ $-40^\circ\text{C} < T_{amb} < +125^\circ\text{C}$	40 30	47		mA
CMRR	Common mode rejection ratio	$0 < V_{ICM} < 2.7\text{ V}$ $-40^\circ\text{C} < T_{amb} < +125^\circ\text{C}$	54 53	74		dB
TP_{HL}	Propagation delay ⁽²⁾ High to low output level	$V_{ICM} = 0\text{ V}$, $R_L = 5.1\text{ k}\Omega$, $C_L = 50\text{ pF}$ Overdrive = 10 mV Overdrive = 100 mV		320 220	320	ns
TP_{LH}	Propagation delay ⁽³⁾ Low to high output level	$V_{ICM} = 0\text{ V}$, $R_L = 5.1\text{ k}\Omega$, $C_L = 50\text{ pF}$ Overdrive = 10 mV Overdrive = 100 mV		550 420	640	ns

1. Maximum values include unavoidable inaccuracies of the industrial tests.
2. TP_{HL} is measured when the output signal crosses a voltage level at 50% of V_{CC} with the following conditions: Inverting input voltage (IN^-) = V_{ICM} and non-inverting input voltage (IN^+) moving from $V_{ICM} + 100\text{ mV}$ to $V_{ICM} - \text{overdrive}$.
3. TP_{LH} is measured when the output signal crosses a voltage level at 50% of V_{CC} with the following conditions: Inverting input voltage (IN^-) = V_{ICM} and non-inverting input voltage (IN^+) moving from $V_{ICM} - 100\text{ mV}$ to $V_{ICM} + \text{overdrive}$.

Table 5. $V_{CC+} = +5\text{ V}$, $V_{CC-} = 0\text{ V}$, $T_{amb} = +25^\circ\text{C}$ (unless otherwise specified)

Symbol	Parameter	Test conditions	Min.	Typ.	Max.	Unit
V_{IO}	Input offset voltage	$-40^\circ\text{C} < T_{amb} < +125^\circ\text{C}$		0.5	5 6	mV
ΔV_{IO}	Input offset voltage drift	$-40^\circ\text{C} < T_{amb} < +125^\circ\text{C}$		1.3		$\mu\text{V}/^\circ\text{C}$
I_{IB}	Input bias current ⁽¹⁾	$-40^\circ\text{C} < T_{amb} < +125^\circ\text{C}$		30	40 100	nA
I_{IO}	Input offset current ⁽¹⁾	$-40^\circ\text{C} < T_{amb} < +125^\circ\text{C}$		1	10 100	nA
I_{CC}	Supply current	No load, output low, $V_{ICM} = 0\text{ V}$ $-40^\circ\text{C} < T_{amb} < +125^\circ\text{C}$		23	30 34	μA
		No load, output high, $V_{ICM} = 0\text{ V}$ $-40^\circ\text{C} < T_{amb} < +125^\circ\text{C}$		26	34 38	
I_{OH}	Output current leakage	$V_{OUT} = V_{CC+}$ $-40^\circ\text{C} < T_{amb} < +125^\circ\text{C}$		1	10 600	nA
V_{OL}	Output voltage low	$I_{SINK} = 4\text{ mA}$ $-40^\circ\text{C} < T_{amb} < +125^\circ\text{C}$		48	60 80	mV
I_{SINK}	Output sink current	$V_{OUT} = 1.5\text{ V}$ $-40^\circ\text{C} < T_{amb} < +125^\circ\text{C}$	82 60	93		mA
A_V	Voltage gain		40	100		V/mV
CMRR	Common mode rejection ratio	$0 < V_{ICM} < 5\text{ V}$ $-40^\circ\text{C} < T_{amb} < +125^\circ\text{C}$	60	79		dB
			58			
SVR	Supply voltage rejection	$\Delta V_{CC} = 1.8\text{ to }5\text{ V}$ $-40^\circ\text{C} < T_{amb} < +125^\circ\text{C}$	56 56	75		dB
TP_{HL}	Propagation delay ⁽²⁾ High to low output level	$V_{ICM} = 0\text{ V}$, $R_L = 5.1\text{ k}\Omega$, $C_L = 50\text{ pF}$ Overdrive = 10 mV Overdrive = 100 mV		380 270	430	ns
TP_{LH}	Propagation delay ⁽³⁾ Low to high output level	$V_{ICM} = 0\text{ V}$, $R_L = 5.1\text{ k}\Omega$, $C_L = 50\text{ pF}$ Overdrive = 10 mV Overdrive = 100 mV		570 450	720	ns

- Maximum values include unavoidable inaccuracies of the industrial tests.
- TP_{HL} is measured when the output signal crosses a voltage level at 50% of V_{CC} with the following conditions: Inverting input voltage (IN-) = V_{ICM} and non-inverting input voltage (IN+) moving from $V_{ICM} + 100\text{ mV}$ to $V_{ICM} - \text{overdrive}$.
- TP_{LH} is measured when the output signal crosses a voltage level at 50% of V_{CC} with the following conditions: Inverting input voltage (IN-) = V_{ICM} and non-inverting input voltage (IN+) moving from $V_{ICM} - 100\text{ mV}$ to $V_{ICM} + \text{overdrive}$.

Figure 2. Supply current versus supply voltage with output high, $V_{ICM} = 0\text{ V}$

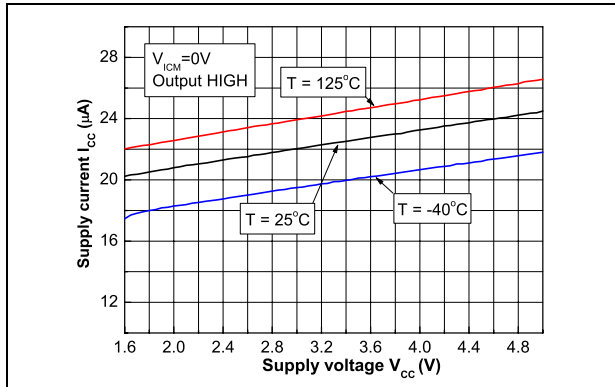

Figure 3. Supply current versus supply voltage with output high, $V_{ICM} = V_{CC}$

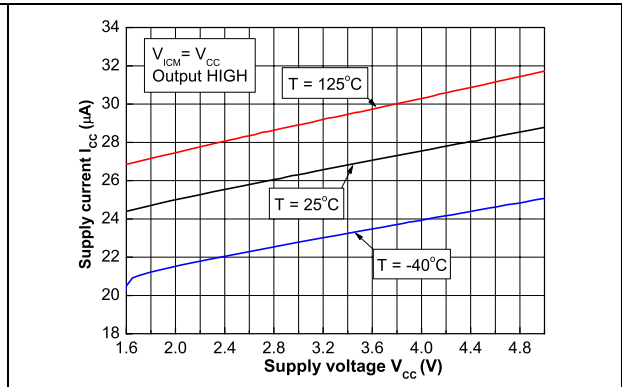

Figure 4. Supply current versus supply voltage with output low, $V_{ICM} = 0\text{ V}$

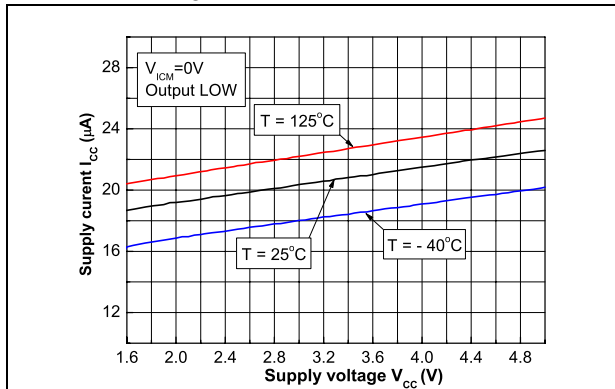

Figure 5. Supply current versus supply voltage with output low, $V_{ICM} = V_{CC}$

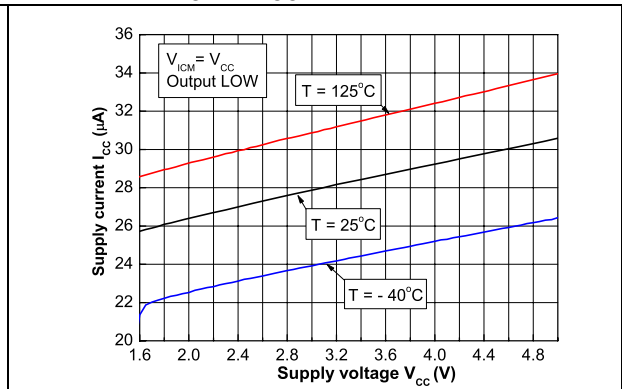

Figure 6. Supply current versus temperature

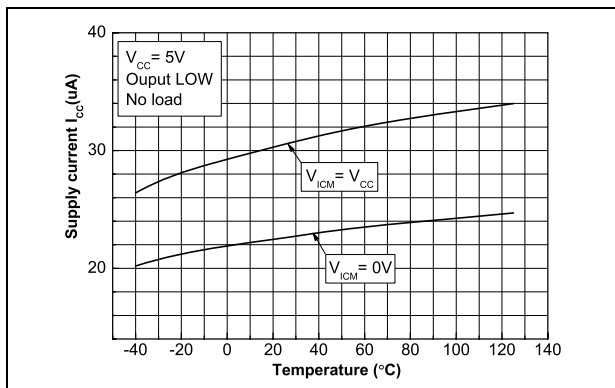

Figure 7. Input bias current versus input common-mode voltage

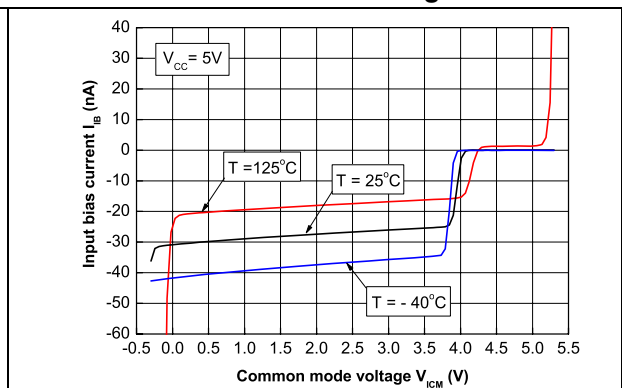

Figure 8. Input current versus differential input voltage

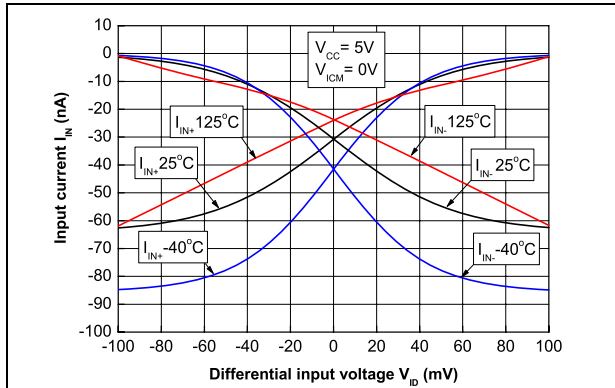

Figure 9. Input offset voltage versus temperature

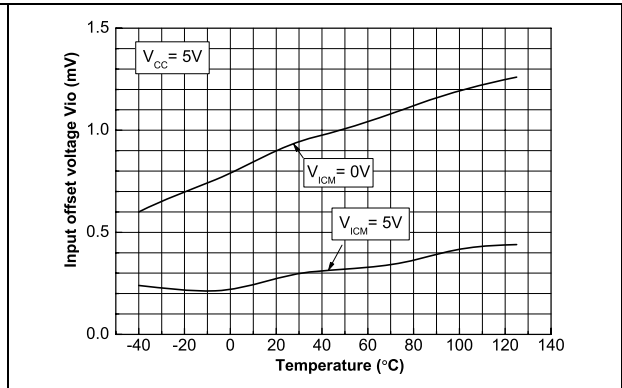

Figure 10. Output voltage versus output sink current, $V_{CC} = 1.8\text{ V}$

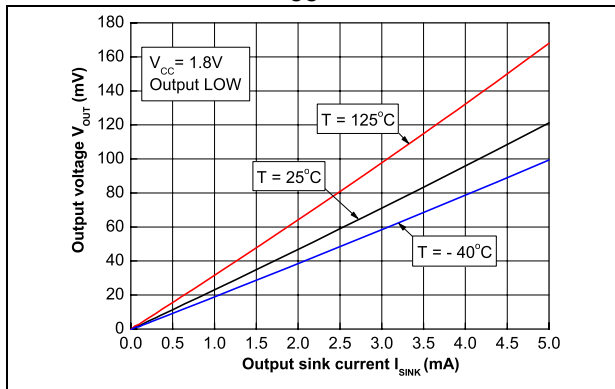

Figure 11. Output voltage versus output sink current, $V_{CC} = 2.7\text{ V}$

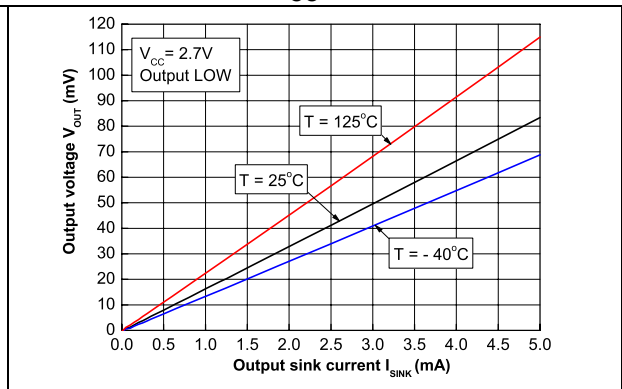

Figure 12. Output voltage versus output sink current, $V_{CC} = 5\text{ V}$

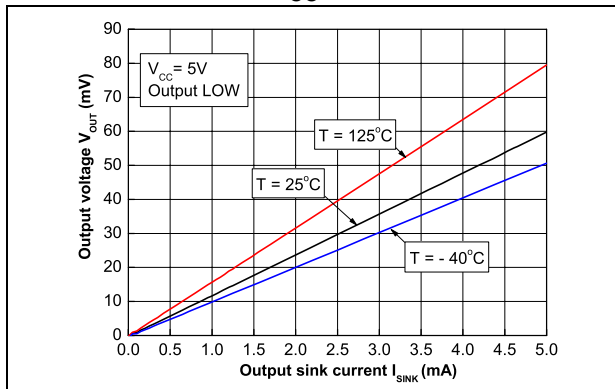

Figure 13. Output sink current versus output voltage

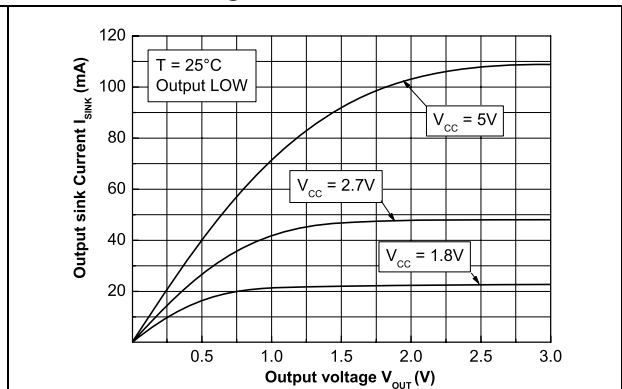

Figure 14. Output voltage versus temperature **Figure 15. Propagation delay versus overdrive with negative transition, $V_{CC} = 1.8\text{ V}$**

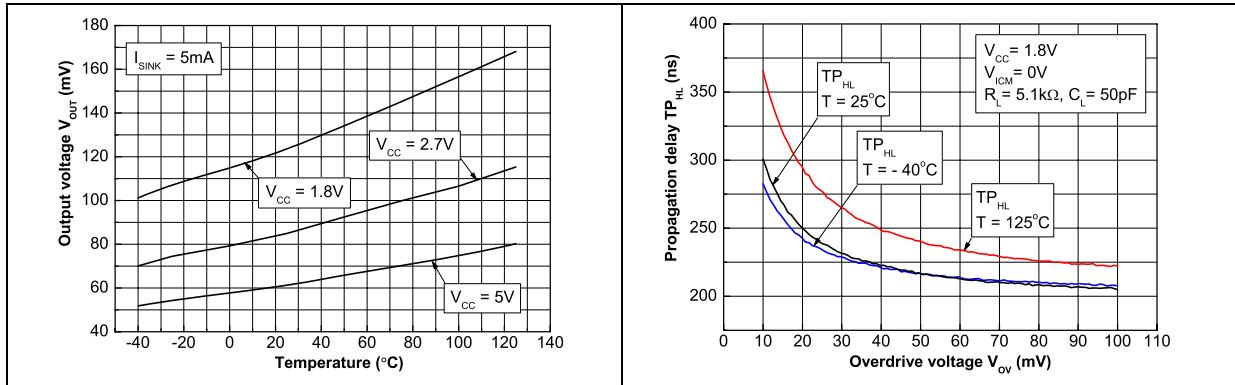

Figure 16. Propagation delay versus overdrive with positive transition, $V_{CC} = 1.8\text{ V}$ **Figure 17. Propagation delay versus common mode voltage, $V_{CC} = 1.8\text{ V}$**

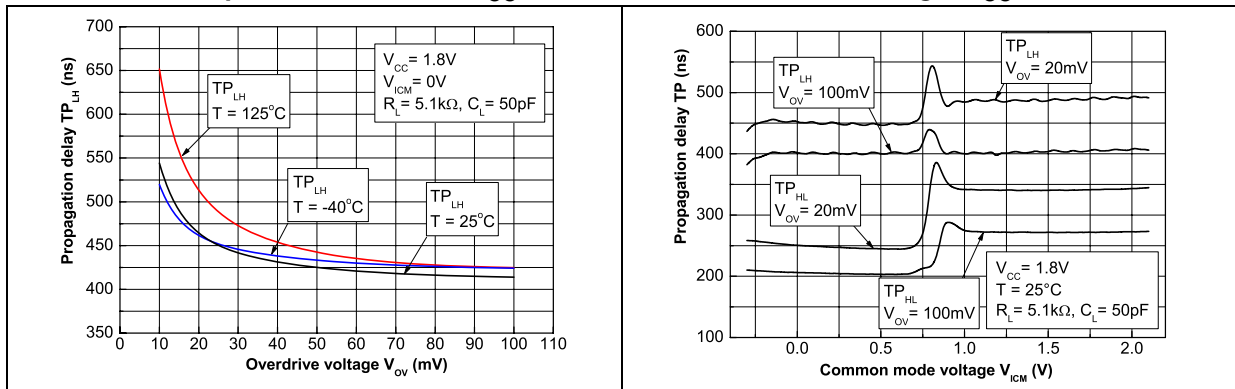

Figure 18. Propagation delay versus overdrive with negative transition, $V_{CC} = 2.7\text{ V}$ **Figure 19. Propagation delay versus overdrive with positive transition, $V_{CC} = 2.7\text{ V}$**

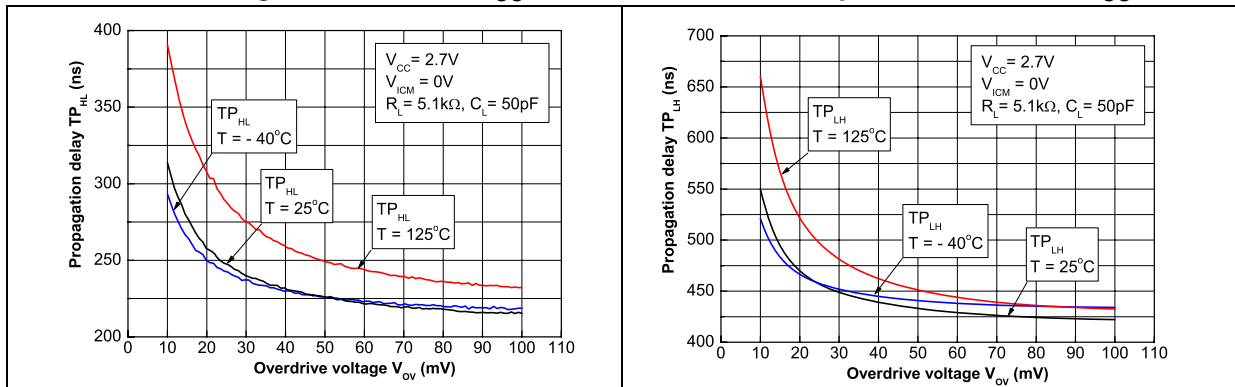

Figure 20. Propagation delay versus common mode voltage, $V_{CC} = 2.7\text{ V}$

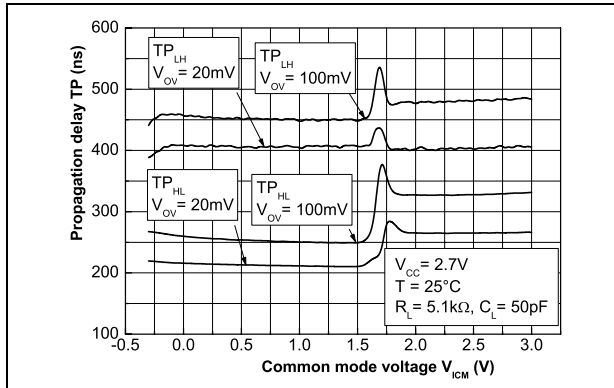

Figure 21. Propagation delay versus overdrive with negative transition, $V_{CC} = 5\text{ V}$

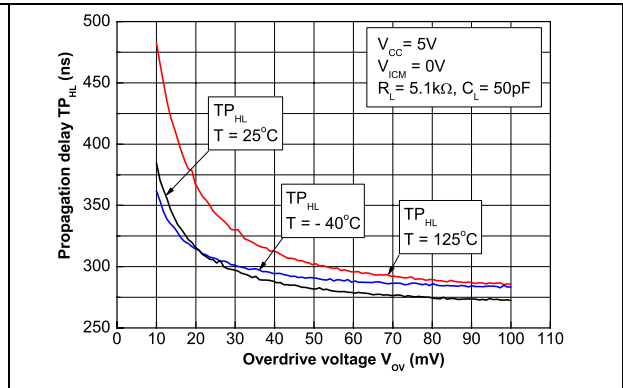

Figure 22. Propagation delay versus overdrive with positive transition, $V_{CC} = 5\text{ V}$

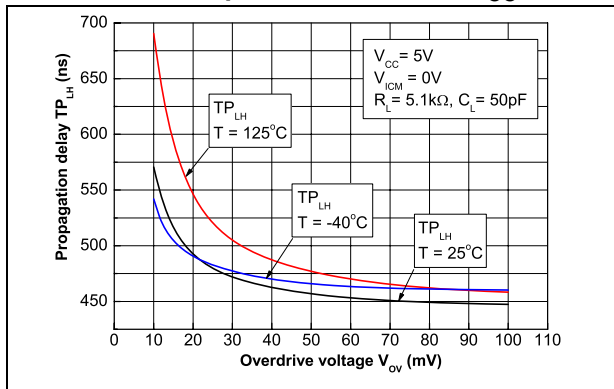

Figure 23. Propagation delay versus common mode voltage, $V_{CC} = 5\text{ V}$

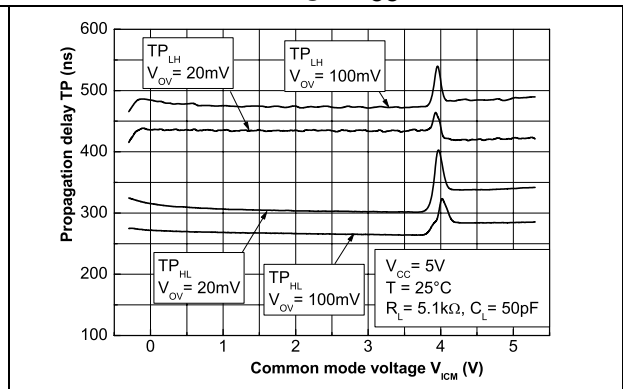

Figure 24. Propagation delay versus time with negative transition

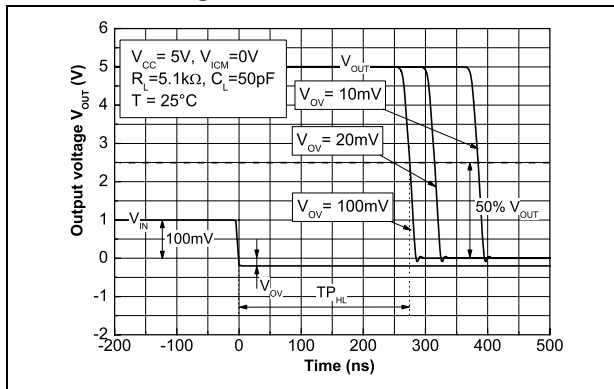
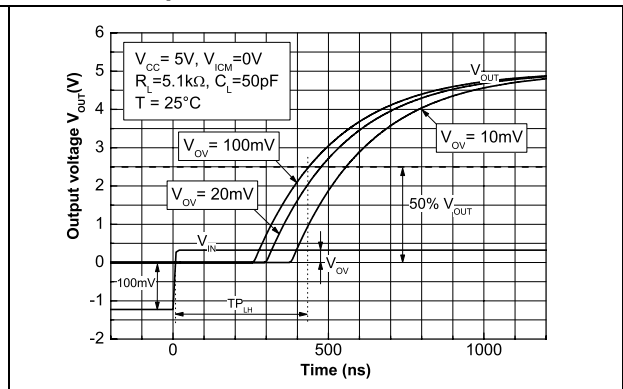

Figure 25. Propagation delay versus time with positive transition



4 Package information

In order to meet environmental requirements, ST offers these devices in different grades of ECOPACK[®] packages, depending on their level of environmental compliance. ECOPACK[®] specifications, grade definitions and product status are available at: www.st.com. ECOPACK[®] is an ST trademark.

4.1 SOT23-5 package

Figure 26. SOT23-5 package mechanical drawing

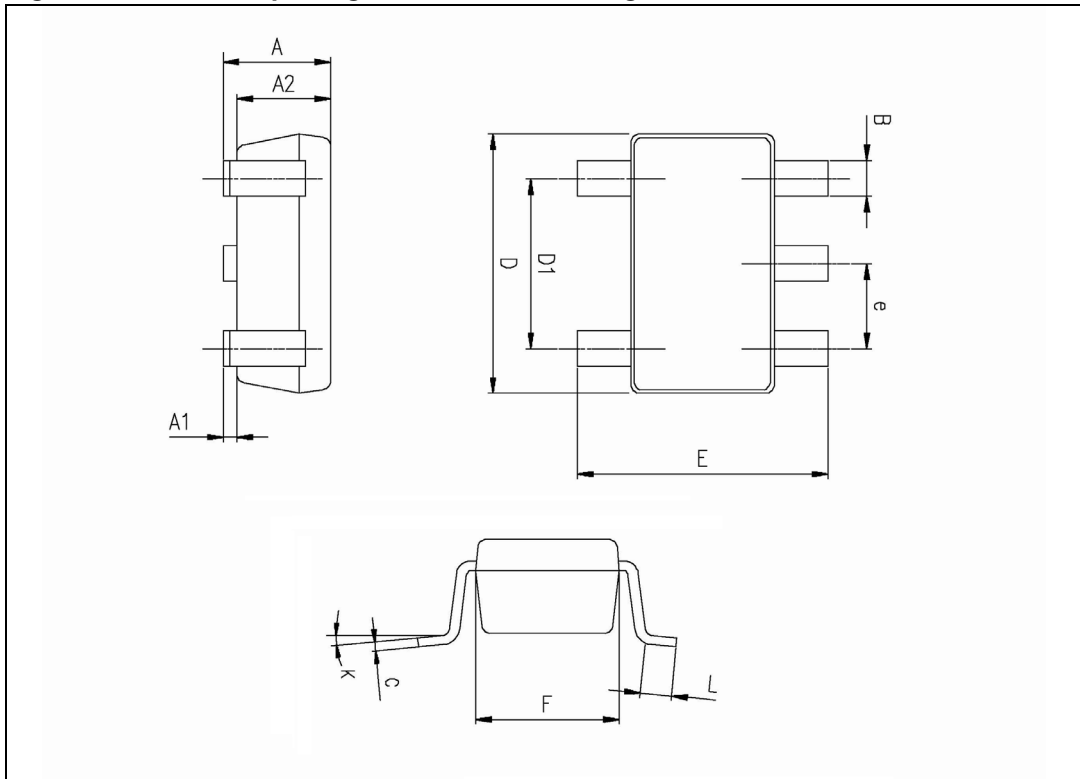

Table 6. SOT23-5 package mechanical data

Ref.	Dimensions					
	Millimeters			Inches		
	Min.	Typ.	Max.	Min.	Typ.	Max.
A	0.90	1.20	1.45	0.035	0.047	0.057
A1			0.15			0.006
A2	0.90	1.05	1.30	0.035	0.041	0.051
B	0.35	0.40	0.50	0.013	0.015	0.019
C	0.09	0.15	0.20	0.003	0.006	0.008
D	2.80	2.90	3.00	0.110	0.114	0.118
D1		1.90			0.075	
e		0.95			0.037	
E	2.60	2.80	3.00	0.102	0.110	0.118
F	1.50	1.60	1.75	0.059	0.063	0.069
L	0.10	0.35	0.60	0.004	0.013	0.023
K	0 degrees		10 degrees			

4.2 SC70-5 (SOT323-5) package

Figure 27. SC70-5 (SOT323-5) package mechanical drawing

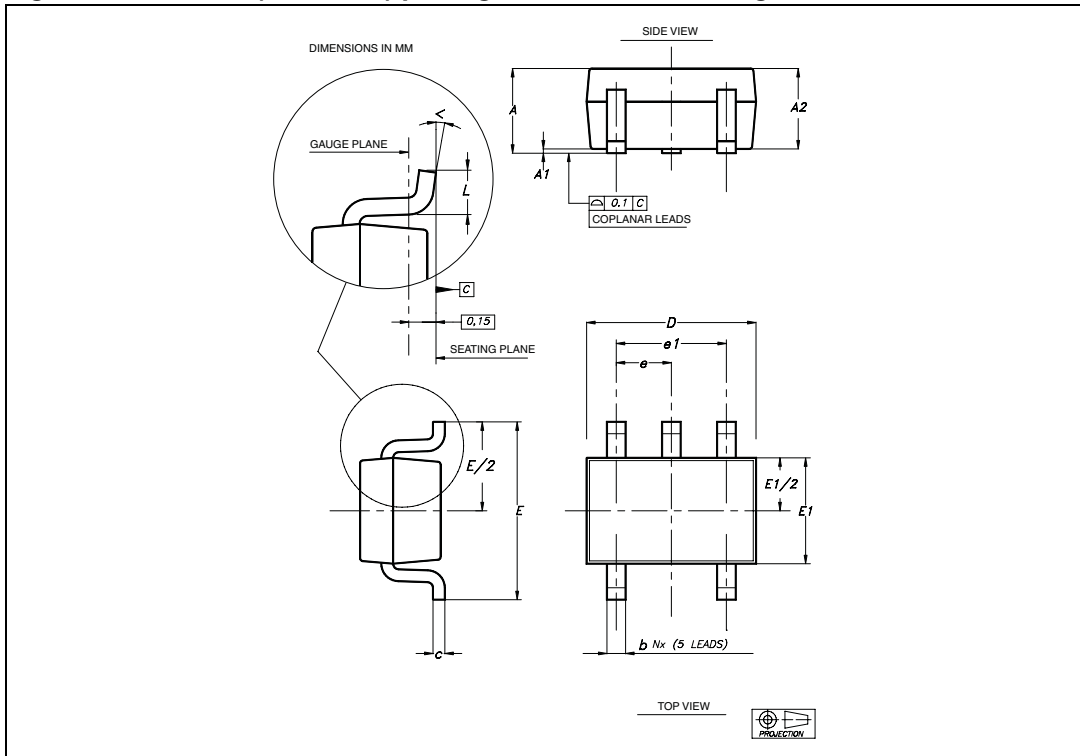

Table 7. SC70-5 (or SOT323-5) package mechanical data

Ref	Dimensions					
	Millimeters			Inches		
	Min	Typ	Max	Min	Typ	Max
A	0.80		1.10	0.315		0.043
A1			0.10			0.004
A2	0.80	0.90	1.00	0.315	0.035	0.039
b	0.15		0.30	0.006		0.012
c	0.10		0.22	0.004		0.009
D	1.80	2.00	2.20	0.071	0.079	0.087
E	1.80	2.10	2.40	0.071	0.083	0.094
E1	1.15	1.25	1.35	0.045	0.049	0.053
e		0.65			0.025	
e1		1.30			0.051	
L	0.26	0.36	0.46	0.010	0.014	0.018
<	0°		8°			

4.3 SO-8 package information

Figure 28. SO-8 package mechanical drawing

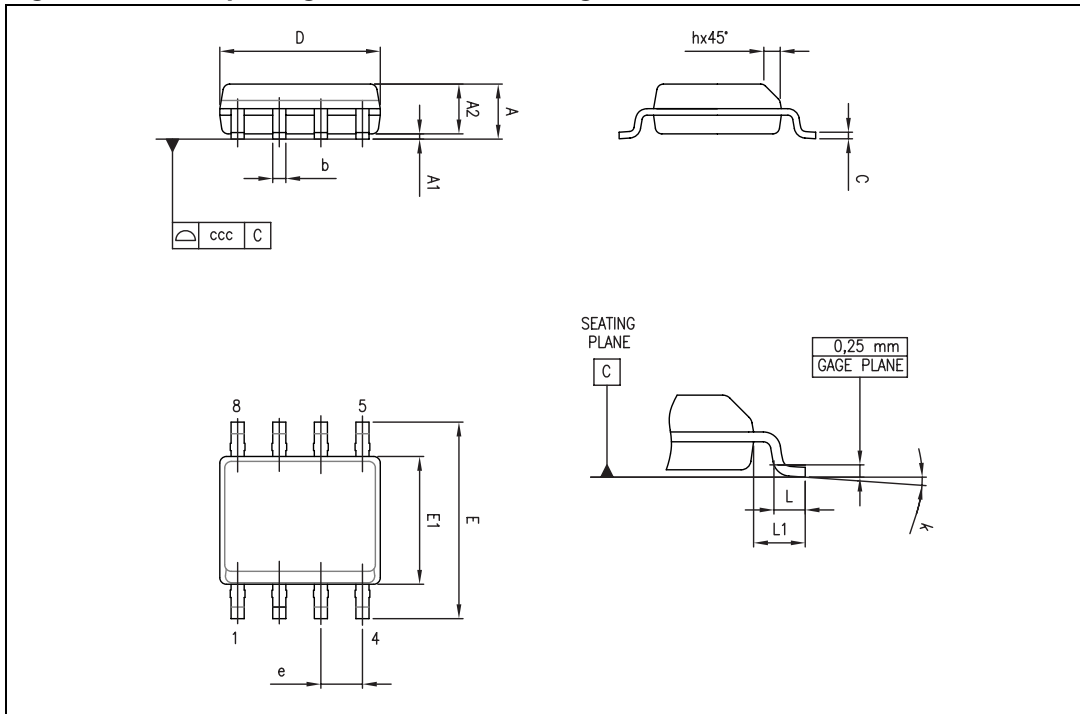

Table 8. SO-8 package mechanical data

Ref.	Dimensions					
	Millimeters			Inches		
	Min.	Typ.	Max.	Min.	Typ.	Max.
A			1.75			0.069
A1	0.10		0.25	0.004		0.010
A2	1.25			0.049		
b	0.28		0.48	0.011		0.019
c	0.17		0.23	0.007		0.010
D	4.80	4.90	5.00	0.189	0.193	0.197
E	5.80	6.00	6.20	0.228	0.236	0.244
E1	3.80	3.90	4.00	0.150	0.154	0.157
e		1.27			0.050	
h	0.25		0.50	0.010		0.020
L	0.40		1.27	0.016		0.050
L1		1.04			0.040	
k	0		8°	1°		8°
ccc			0.10			0.004

4.4 MiniSO-8 package information

Figure 29. MiniSO-8 package mechanical drawing

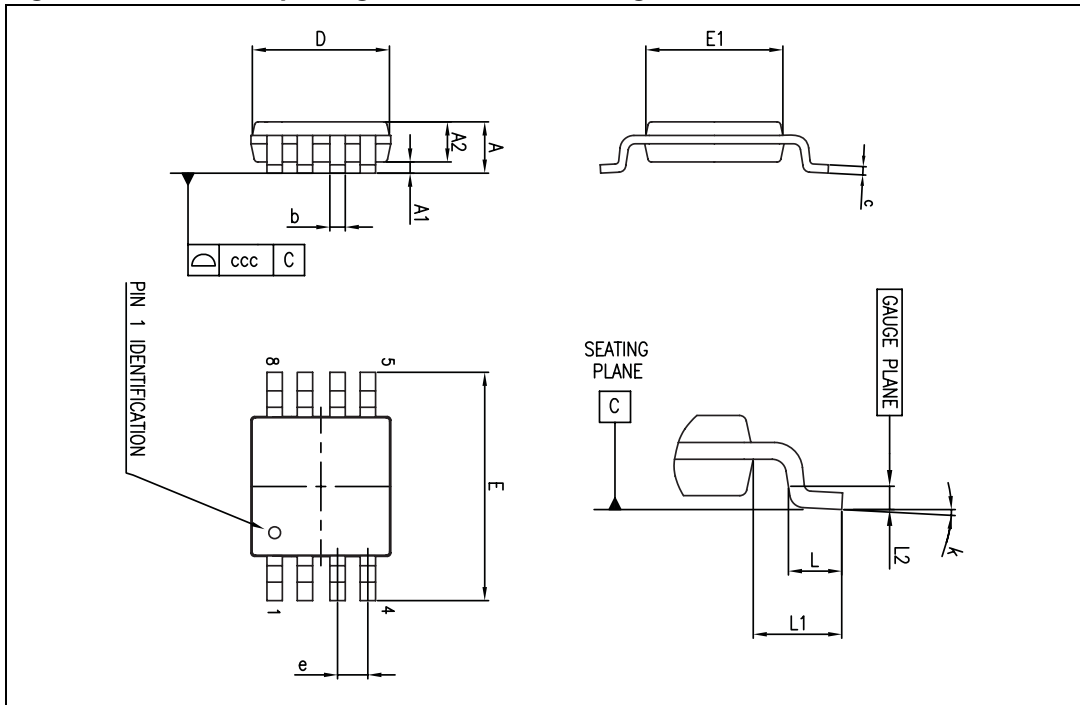

Table 9. MiniSO-8 package mechanical data

Ref.	Dimensions					
	Millimeters			Inches		
	Min.	Typ.	Max.	Min.	Typ.	Max.
A			1.1			0.043
A1	0		0.15	0		0.006
A2	0.75	0.85	0.95	0.030	0.033	0.037
b	0.22		0.40	0.009		0.016
c	0.08		0.23	0.003		0.009
D	2.80	3.00	3.20	0.11	0.118	0.126
E	4.65	4.90	5.15	0.183	0.193	0.203
E1	2.80	3.00	3.10	0.11	0.118	0.122
e		0.65			0.026	
L	0.40	0.60	0.80	0.016	0.024	0.031
L1		0.95			0.037	
L2		0.25			0.010	
k	0°		8°	0°		8°
ccc			0.10			0.004

4.5 SO-14 package information

Figure 30. SO-14 package mechanical drawing

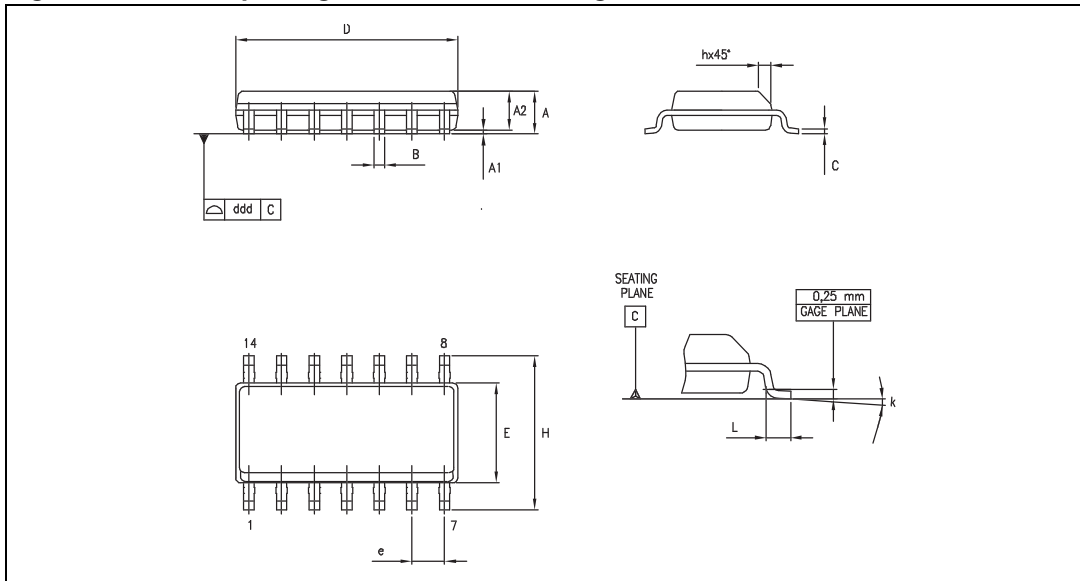

Table 10. SO-14 package mechanical data

Dimensions						
Ref.	Millimeters			Inches		
	Min.	Typ.	Max.	Min.	Typ.	Max.
A	1.35		1.75	0.05		0.068
A1	0.10		0.25	0.004		0.009
A2	1.10		1.65	0.04		0.06
B	0.33		0.51	0.01		0.02
C	0.19		0.25	0.007		0.009
D	8.55		8.75	0.33		0.34
E	3.80		4.0	0.15		0.15
e		1.27			0.05	
H	5.80		6.20	0.22		0.24
h	0.25		0.50	0.009		0.02
L	0.40		1.27	0.015		0.05
k	8° (max.)					
ddd			0.10			0.004

4.6 TSSOP14 package information

Figure 31. TSSOP14 package mechanical drawing

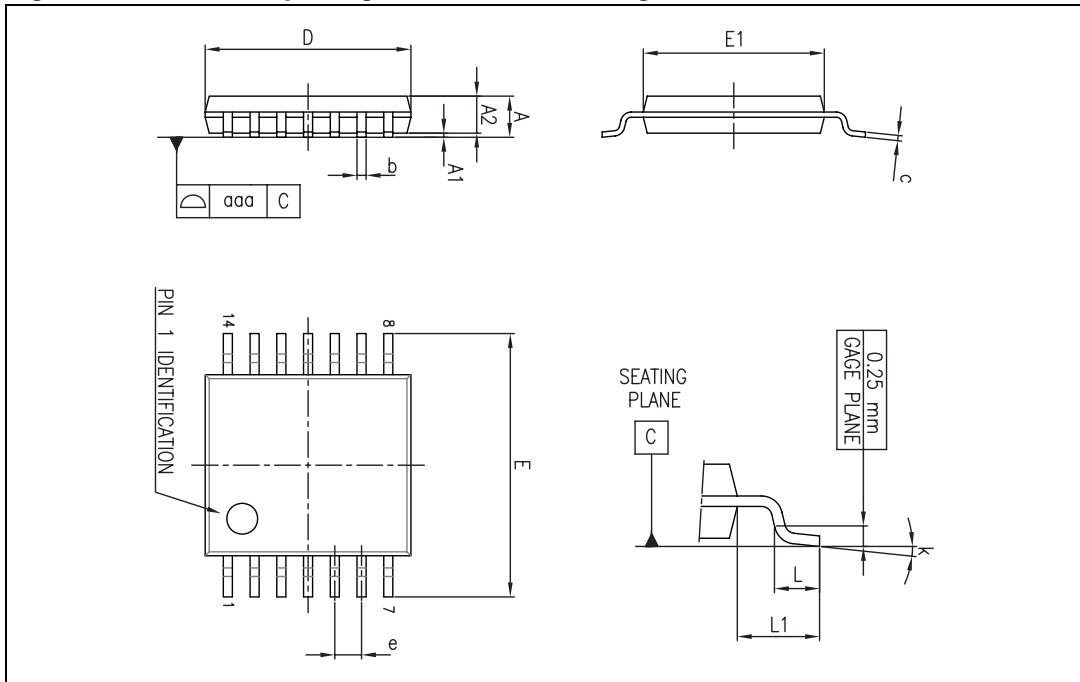

Table 11. TSSOP14 package mechanical data

Ref.	Dimensions					
	Millimeters			Inches		
	Min.	Typ.	Max.	Min.	Typ.	Max.
A			1.20			0.047
A1	0.05		0.15	0.002	0.004	0.006
A2	0.80	1.00	1.05	0.031	0.039	0.041
b	0.19		0.30	0.007		0.012
c	0.09		0.20	0.004		0.0089
D	4.90	5.00	5.10	0.193	0.197	0.201
E	6.20	6.40	6.60	0.244	0.252	0.260
E1	4.30	4.40	4.50	0.169	0.173	0.176
e		0.65			0.0256	
L	0.45	0.60	0.75	0.018	0.024	0.030
L1		1.00			0.039	
k	0°		8°	0°		8°
aaa			0.10			0.004

5 Ordering information

Table 12. Order codes

Part number	Temperature range	Package	Packaging	Marking
TS331ILT	-40°C, +125°C	SOT23-5	Tape & reel	K506
TS331ICT		SC70-5		K55
TS332IDT		SO8		332I
TS332IST		MiniSO8		K507
TS334IDT		SO14		334I
TS334IPT		TSSOP14		334I

6 Revision history

Table 13. Document revision history

Date	Revision	Changes
29-Mar-2010	1	Initial release.
01-Dec-2011	2	<ul style="list-style-type: none"> – Added TS332 and TS334 devices. – Added V_{out} parameter in Table 1: Absolute maximum ratings. – Removed note "The magnitude of input and output voltages must never exceed the supply rail ± 0.3 V." from Table 1. – Removed note "All values over the temperature range are guaranteed through correlation and simulation. No production tests have been performed at the temperature range limits." from Table 3, Table 4 and Table 5. – Removed "$V_{icm} = 0$ V" from Test conditions column in Table 3, Table 4 and Table 5. – Modified minimal I_{sink} value in Table 5.

Please Read Carefully:

Information in this document is provided solely in connection with ST products. STMicroelectronics NV and its subsidiaries ("ST") reserve the right to make changes, corrections, modifications or improvements, to this document, and the products and services described herein at any time, without notice.

All ST products are sold pursuant to ST's terms and conditions of sale.

Purchasers are solely responsible for the choice, selection and use of the ST products and services described herein, and ST assumes no liability whatsoever relating to the choice, selection or use of the ST products and services described herein.

No license, express or implied, by estoppel or otherwise, to any intellectual property rights is granted under this document. If any part of this document refers to any third party products or services it shall not be deemed a license grant by ST for the use of such third party products or services, or any intellectual property contained therein or considered as a warranty covering the use in any manner whatsoever of such third party products or services or any intellectual property contained therein.

UNLESS OTHERWISE SET FORTH IN ST'S TERMS AND CONDITIONS OF SALE ST DISCLAIMS ANY EXPRESS OR IMPLIED WARRANTY WITH RESPECT TO THE USE AND/OR SALE OF ST PRODUCTS INCLUDING WITHOUT LIMITATION IMPLIED WARRANTIES OF MERCHANTABILITY, FITNESS FOR A PARTICULAR PURPOSE (AND THEIR EQUIVALENTS UNDER THE LAWS OF ANY JURISDICTION), OR INFRINGEMENT OF ANY PATENT, COPYRIGHT OR OTHER INTELLECTUAL PROPERTY RIGHT.

UNLESS EXPRESSLY APPROVED IN WRITING BY TWO AUTHORIZED ST REPRESENTATIVES, ST PRODUCTS ARE NOT RECOMMENDED, AUTHORIZED OR WARRANTED FOR USE IN MILITARY, AIR CRAFT, SPACE, LIFE SAVING, OR LIFE SUSTAINING APPLICATIONS, NOR IN PRODUCTS OR SYSTEMS WHERE FAILURE OR MALFUNCTION MAY RESULT IN PERSONAL INJURY, DEATH, OR SEVERE PROPERTY OR ENVIRONMENTAL DAMAGE. ST PRODUCTS WHICH ARE NOT SPECIFIED AS "AUTOMOTIVE GRADE" MAY ONLY BE USED IN AUTOMOTIVE APPLICATIONS AT USER'S OWN RISK.

Resale of ST products with provisions different from the statements and/or technical features set forth in this document shall immediately void any warranty granted by ST for the ST product or service described herein and shall not create or extend in any manner whatsoever, any liability of ST.

ST and the ST logo are trademarks or registered trademarks of ST in various countries.

Information in this document supersedes and replaces all information previously supplied.

The ST logo is a registered trademark of STMicroelectronics. All other names are the property of their respective owners.

© 2011 STMicroelectronics - All rights reserved

STMicroelectronics group of companies

Australia - Belgium - Brazil - Canada - China - Czech Republic - Finland - France - Germany - Hong Kong - India - Israel - Italy - Japan - Malaysia - Malta - Morocco - Philippines - Singapore - Spain - Sweden - Switzerland - United Kingdom - United States of America

www.st.com