



# TSV85x, TSV85xA

Low-power, high accuracy, general-purpose operational amplifier

## Features

- Low power consumption: 180  $\mu$ A max at 5 V
- Low power shutdown mode: 50 nA max
- Low offset voltage: 0.8 mV max at 25°C
- Tiny packages
- Extended temperature range: -40°C to +125°C
- Low supply voltage: 2.5 V - 5.5 V
- Gain bandwidth product: 1.3 MHz

## Benefits

- Longer lifetime in battery-powered applications
- Higher accuracy without calibration
- Smaller form factor than equivalent competitor devices
- Application performances guaranteed over wide temperature ranges

## Related products

- See LMV82x series for higher gain bandwidth product (5.5 MHz)

## Applications

- Battery-powered applications
- Portable devices
- Signal conditioning
- Active filtering
- Medical instrumentation

## Description

The TSV85x series of single, dual and quad operational amplifiers offers low voltage operation with a rail-to-rail output swing. The TSV85x series outperforms the industry standard LMV321, proposing lower supply voltage capability, enhanced input offset voltage and smaller packages.

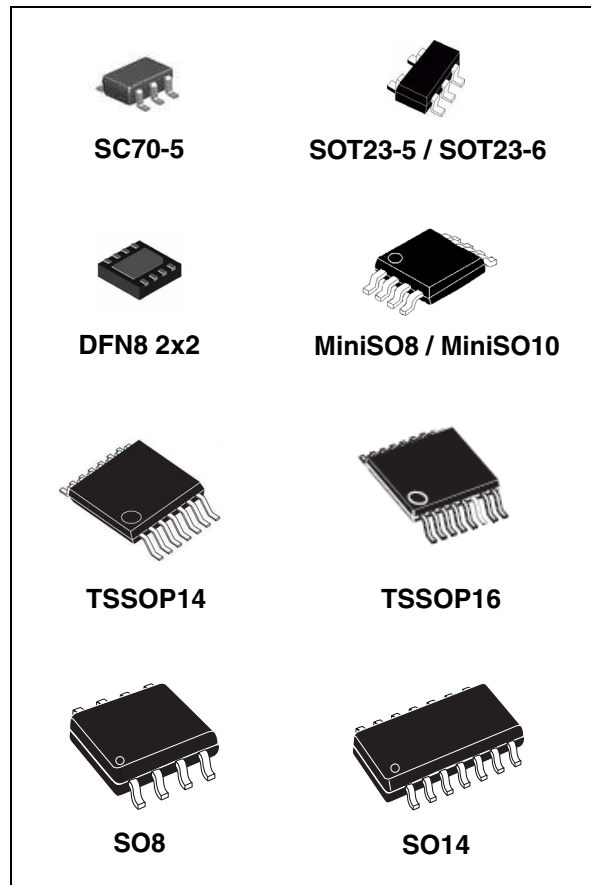

The devices are offered with either industry standard pinouts or with a power-saving shutdown feature that reduces the supply current to a maximum of 50 nA at 25°C.

**Table 1. Device summary**

	Without shutdown feature		With shutdown feature	
	Standard V <sub>io</sub>	Enhanced V <sub>io</sub>	Standard V <sub>io</sub>	Enhanced V <sub>io</sub>
Single	TSV851	TSV851A	TSV850	TSV850A
Dual	TSV852	TSV852A	TSV853	TSV853A
Quad	TSV854	TSV854A	TSV855	TSV855A

# Contents

<b>1</b>	<b>Package pin connections</b> .....	<b>3</b>
<b>2</b>	<b>Absolute maximum ratings and operating conditions</b> .....	<b>4</b>
<b>3</b>	<b>Electrical characteristics</b> .....	<b>6</b>
<b>4</b>	<b>Application information</b> .....	<b>14</b>
	4.1 Operating voltages .....	14
	4.2 Input common-mode range .....	14
	4.3 Rail-to-rail output .....	14
	4.4 Input offset voltage drift over temperature .....	14
	4.5 PCB layouts .....	14
	4.6 Macromodel .....	14
	4.7 Shutdown function .....	15
<b>5</b>	<b>Package information</b> .....	<b>16</b>
	5.1 SO-8 package information .....	17
	5.2 SO-14 package information .....	18
	5.3 TSSOP14 package information .....	19
	5.4 TSSOP16 package information .....	20
	5.5 MiniSO-8 package information .....	21
	5.6 MiniSO-10 package information .....	22
	5.7 DFN8 package information .....	23
	5.8 SOT23-5 package information .....	24
	5.9 SOT23-6 package information .....	25
	5.10 SC70-5 (or SOT323-5) package information .....	26
<b>6</b>	<b>Ordering information</b> .....	<b>27</b>
<b>7</b>	<b>Revision history</b> .....	<b>28</b>

# 1 Package pin connections

Figure 1. Pin connections for each package (top view)

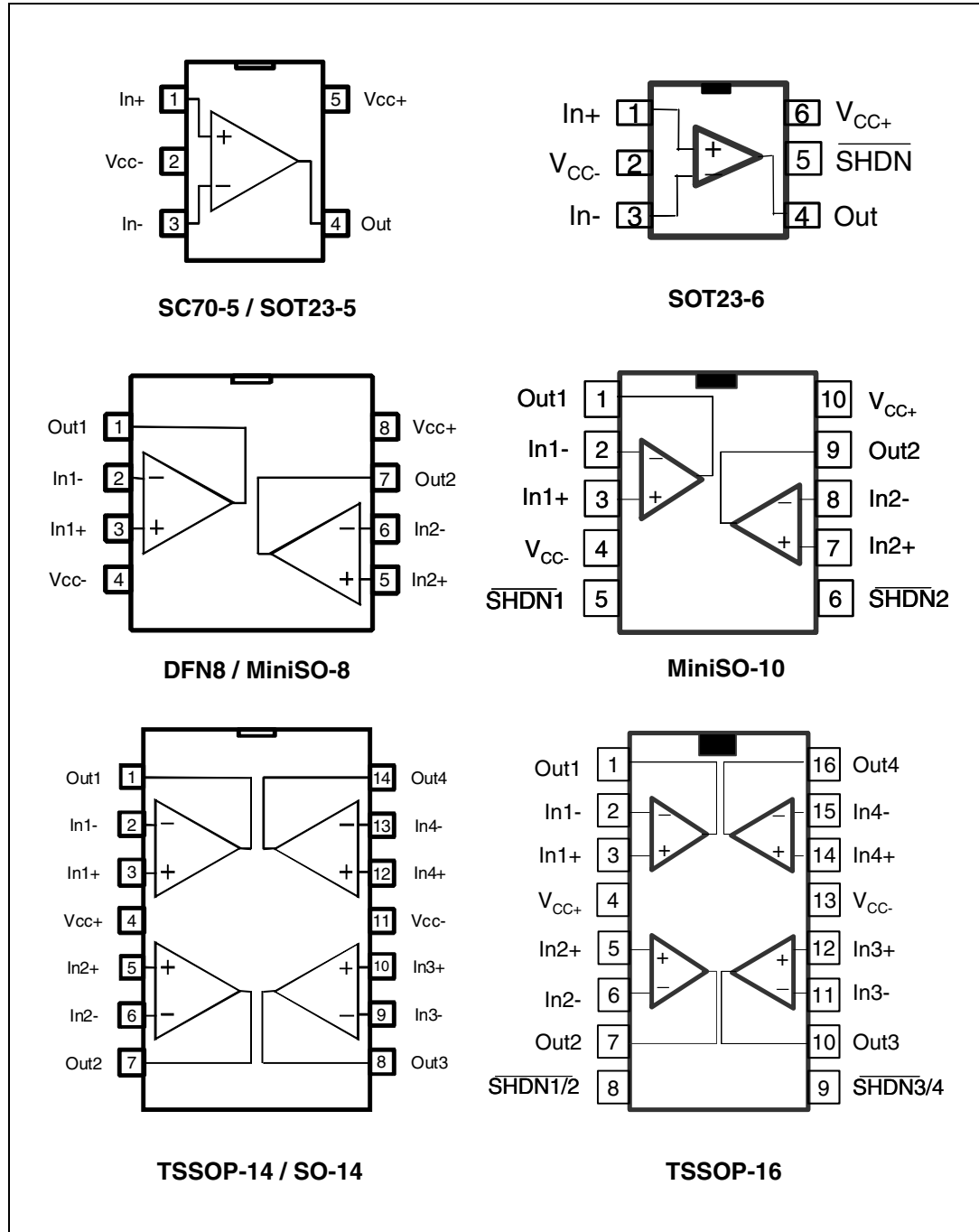

## 2 Absolute maximum ratings and operating conditions

**Table 2. Absolute maximum ratings (AMR)**

Symbol	Parameter	Value	Unit
$V_{CC}$	Supply voltage <sup>(1)</sup>	6	V
$V_{id}$	Differential input voltage <sup>(2)</sup>	$\pm V_{CC}$	V
$V_{in}$	Input pins (IN+ and IN- pins) voltage <sup>(3)</sup>	$V_{CC-} - 0.3$ to $V_{CC+} + 0.3$	V
$I_{in}$	Input current <sup>(4)</sup>	10	mA
$\overline{SHDN}$	Shutdown voltage <sup>(5)</sup>	$V_{CC-} - 0.2$ to $V_{CC+} + 0.2$	V
$T_{stg}$	Storage temperature	-65 to +150	°C
$R_{thja}$	Thermal resistance junction to ambient <sup>(6)(7)</sup>		°C/W
	SC70-5	205	
	SOT23-5	250	
	DFN8 2x2	57	
	MiniSO8	190	
	SO8	125	
	TSSOP14	100	
	SO14	105	
	SOT23-6	240	
	MiniSO10	113	
TSSOP16	95		
$T_j$	Maximum junction temperature	150	°C
ESD	HBM: human body model (except shutdown pin) <sup>(8)</sup>	4	kV
	HBM: human body model (shutdown pin) <sup>(8)</sup>	3.5	kV
	MM: machine model <sup>(9)</sup>	250	V
	CDM: charged device model <sup>(10)</sup>	1.3	kV
	CDM: charged device model TSV855 <sup>(10)</sup>	1	kV
	Latch-up immunity	200	mA

1. All voltage values, except differential voltage, are with respect to network ground terminal.
2. Differential voltages are the non-inverting input terminal with respect to the inverting input terminal.
3.  $V_{CC-} - V_{in}$  must not exceed 6 V,  $V_{in}$  must not exceed 6 V.
4. Input current must be limited by a resistor in series with the inputs.
5.  $V_{CC-} - V_{shdn}$  must not exceed 6 V,  $V_{in}$  must not exceed 6 V.
6. Short-circuits can cause excessive heating and destructive dissipation.
7.  $R_{th}$  are typical values.
8. Human body model: 100 pF discharged through a 1.5 kΩ resistor between two pins of the device, done for all couples of pin combinations with other pins floating.
9. Machine model: a 200 pF cap is charged to the specified voltage, then discharged directly between two pins of the device with no external series resistor (internal resistor < 5 Ω), done for all couples of pin combinations with other pins floating.
10. Charged device model: all pins plus package are charged together to the specified voltage and then discharged directly to the ground.

**Table 3. Operating conditions**

Symbol	Parameter	Value	Unit
$V_{CC}$	Supply voltage	2.5 to 5.5	V
$V_{icm}$	Common mode input voltage range	$V_{CC-} - 0.2$ to $V_{CC+} - 1$	V
$T_{oper}$	Operating free air temperature range	-40 to +125	°C

### 3 Electrical characteristics

Table 4. Electrical characteristics at  $V_{CC+} = 2.7\text{ V}$  with  $V_{CC-} = 0\text{ V}$ ,  $V_{icm} = V_{CC}/2$ ,  $T_{amb} = 25^\circ\text{ C}$ , and  $R_L$  connected to  $V_{CC}/2$  (unless otherwise specified)

Symbol	Parameter	Conditions	Min.	Typ.	Max.	Unit
<b>DC performance</b>						
$V_{io}$	Input offset voltage	TSV85xA, $T=25^\circ\text{C}$			0.8	mV
		TSV85x, $T=25^\circ\text{C}$			4	
		TSV85xA, $-40^\circ\text{C} < T < 125^\circ\text{C}$			2	
		TSV85x, $-40^\circ\text{C} < T < 125^\circ\text{C}$			6	
$\Delta V_{io}/\Delta T$	Input offset voltage drift <sup>(1)</sup>	$-40^\circ\text{C} < T < 125^\circ\text{C}$		1		$\mu\text{V}/^\circ\text{C}$
$I_{io}$	Input offset current ( $V_{out} = V_{CC}/2$ )	$T=25^\circ\text{C}$		0.5	30	nA
		$-40^\circ\text{C} < T < 125^\circ\text{C}$		1	50	
$I_{ib}$	Input bias current ( $V_{out} = V_{CC}/2$ )	$T=25^\circ\text{C}$		27	60	nA
		$-40^\circ\text{C} < T < 125^\circ\text{C}$			110	
CMR	Common mode rejection ratio $20 \log (\Delta V_{icm}/\Delta V_{io})$ ( $V_{ic} = 0\text{ V}$ to $V_{CC}-1\text{V}$ , $V_{out} = V_{CC}/2$ )	$T=25^\circ\text{C}$	70	75		dB
		$-40^\circ\text{C} < T < 125^\circ\text{C}$	68			
$A_{vd}$	Large signal voltage gain ( $V_{out} = 0.5\text{V}$ to $(V_{CC}-0.5\text{V})$ )	$R_L = 10\text{ k}\Omega$ , $T=25^\circ\text{C}$	100	110		dB
		$R_L = 10\text{ k}\Omega$ , $-40^\circ\text{C} < T < 125^\circ\text{C}$	90			
		$R_L = 2\text{ k}\Omega$ , $T=25^\circ\text{C}$	90	100		
		$R_L = 2\text{ k}\Omega$ , $-40^\circ\text{C} < T < 125^\circ\text{C}$	80			
$V_{CC}-V_{OH}$	High level output voltage	$R_L = 10\text{ k}\Omega$ , $T=25^\circ\text{C}$		10	100	mV
		$R_L = 10\text{ k}\Omega$ , $-40^\circ\text{C} < T < 125^\circ\text{C}$			200	
		$R_L = 2\text{ k}\Omega$ , $T=25^\circ\text{C}$		40	300	
		$R_L = 2\text{ k}\Omega$ , $-40^\circ\text{C} < T < 125^\circ\text{C}$			400	
$V_{OL}$	Low level output voltage	$R_L = 10\text{ k}\Omega$ , $T=25^\circ\text{C}$		65	180	mV
		$R_L = 10\text{ k}\Omega$ , $-40^\circ\text{C} < T < 125^\circ\text{C}$			280	
		$R_L = 2\text{ k}\Omega$ , $T=25^\circ\text{C}$		120	300	
		$R_L = 2\text{ k}\Omega$ , $-40^\circ\text{C} < T < 125^\circ\text{C}$			400	
$I_{out}$	$I_{sink}$ ( $V_{out} = V_{CC}$ ) $V_{id} = -1\text{ V}$	$T=25^\circ\text{C}$	15	26		mA
		$-40^\circ\text{C} < T < 125^\circ\text{C}$	15			
	$I_{source}$ ( $V_{out} = 0\text{ V}$ ) $V_{id} = 1\text{ V}$	$T = 25^\circ\text{C}$	15	21		mA
		$-40^\circ\text{C} < T < 125^\circ\text{C}$	12			
$I_{CC}$	Supply current (per channel) No load, $V_{out} = V_{CC}/2$	$T = 25^\circ\text{C}$		120	180	$\mu\text{A}$
		$-40^\circ\text{C} < T < 125^\circ\text{C}$			180	

**Table 4. Electrical characteristics at  $V_{CC+} = 2.7\text{ V}$  with  $V_{CC-} = 0\text{ V}$ ,  $V_{icm} = V_{CC}/2$ ,  $T_{amb} = 25^\circ\text{ C}$ , and  $R_L$  connected to  $V_{CC}/2$  (unless otherwise specified) (continued)**

Symbol	Parameter	Conditions	Min.	Typ.	Max.	Unit
<b>AC performance</b>						
GBP	Gain bandwidth product	$R_L > 1\text{ M}\Omega$ , $C_L = 200\text{ pF}$		1.3		MHz
$F_u$	Unity gain frequency	$R_L > 1\text{ M}\Omega$ , $C_L = 200\text{ pF}$		1		MHz
$\Phi_m$	Phase margin	$R_L > 1\text{ M}\Omega$ , $C_L = 200\text{ pF}$		60		degrees
$G_m$	Gain margin	$R_L > 1\text{ M}\Omega$ , $C_L = 200\text{ pF}$		10		dB
SR	Slew rate	$R_L > 1\text{ M}\Omega$ , $C_L = 200\text{ pF}$ $V_{out} = 0.5\text{ V}$ to $V_{CC} - 0.5\text{ V}$		0.6		V/ $\mu\text{s}$
$e_n$	Equivalent input noise voltage	$f = 1\text{ kHz}$ $f = 10\text{ kHz}$		31 20		$\frac{\text{nV}}{\sqrt{\text{Hz}}}$
$i_n$	Equivalent input noise current	$f = 1\text{ kHz}$		0.30		$\frac{\text{pA}}{\sqrt{\text{Hz}}}$
THD+N	Total harmonic distortion + noise	$f_{in} = 1\text{ kHz}$ , $A_{CL} = 1$ , $R_L = 10\text{ k}\Omega$ , $V_{icm} = V_{CC}/2$ , $BW = 22\text{ kHz}$ , $V_{out} = 1\text{ V}_{pp}$		0.002		%

**Table 5. Shutdown characteristics  $V_{CC} = 2.7\text{ V}$**

Symbol	Parameter	Conditions	Min.	Typ.	Max.	Unit
<b>DC performance</b>						
$I_{CC}$	Supply current in shutdown mode (all operators)	$\overline{\text{SHDN}} = V_{CC-}$		2.5	50	nA
		$-40^\circ\text{C} < T < 85^\circ\text{C}$			200	nA
		$-40^\circ\text{C} < T < 125^\circ\text{C}$			1.5	$\mu\text{A}$
$t_{on}$	Amplifier turn-on time <sup>(1)</sup>	$R_L = 2\text{ k}\Omega$ $V_{out} = V_{CC-}$ to $V_{CC-} + 0.2\text{ V}$		300		ns
$t_{off}$	Amplifier turn-off time <sup>(1)</sup>	$R_L = 2\text{ k}\Omega$ , $V_{out} = V_{CC+} - 1\text{ V}$ to $V_{CC+} - 1.2\text{ V}$		20		ns
$V_{IH}$	$\overline{\text{SHDN}}$ logic high		$V_{CC-}$ 0.5			V
$V_{IL}$	$\overline{\text{SHDN}}$ logic low				0.5	V
$I_{IH}$	$\overline{\text{SHDN}}$ current high	$\overline{\text{SHDN}} = V_{CC+}$		10		pA
$I_{IL}$	$\overline{\text{SHDN}}$ current low	$\overline{\text{SHDN}} = V_{CC-}$		10		pA
$I_{OLeak}$	Output leakage in shutdown mode	$\overline{\text{SHDN}} = V_{CC-}$		50		pA
		$-40^\circ\text{C} < T < 125^\circ\text{C}$		1		nA

1. See [Section 4.7: Shutdown function on page 15](#).

**Table 6. Electrical characteristics at  $V_{CC+} = 5\text{ V}$  with  $V_{CC-} = 0\text{ V}$ ,  $V_{icm} = V_{CC}/2$ ,  $T_{amb} = 25^\circ\text{ C}$ , and  $R_L$  connected to  $V_{CC}/2$  (unless otherwise specified)**

Symbol	Parameter	Conditions	Min.	Typ.	Max.	Unit
<b>DC performance</b>						
$V_{io}$	Input offset voltage	TSV85xA, $T = 25^\circ\text{C}$			0.8	mV
		TSV85x, $T = 25^\circ\text{C}$			4	
		TSV85xA, $-40^\circ\text{C} < T < 125^\circ\text{C}$			2	
		TSV85x, $-40^\circ\text{C} < T < 125^\circ\text{C}$			6	
$\Delta V_{io}/\Delta T$	Input offset voltage drift <sup>(1)</sup>	$-40^\circ\text{C} < T < 125^\circ\text{C}$		1		$\mu\text{V}/^\circ\text{C}$
$I_{io}$	Input offset current ( $V_{out} = V_{CC}/2$ )	$T = 25^\circ\text{C}$		0.5	30	nA
		$-40^\circ\text{C} < T < 125^\circ\text{C}$		1	50	
$I_{ib}$	Input bias current ( $V_{out} = V_{CC}/2$ )	$T = 25^\circ\text{C}$		27	60	nA
		$-40^\circ\text{C} < T < 125^\circ\text{C}$			110	
CMR	Common mode rejection ratio $20 \log (\Delta V_{icm}/\Delta V_{io})$ ( $V_{ic} = 0\text{ V}$ to $V_{CC}-1\text{ V}$ , $V_{out} = V_{CC}/2$ )	$T = 25^\circ\text{C}$	72	75		dB
		$-40^\circ\text{C} < T < 125^\circ\text{C}$	70			
SVR	Supply voltage rejection ratio: $20 \log (\Delta V_{CC}/\Delta V_{io})$ $V_{CC} = 2.5$ to $5\text{ V}$	$T = 25^\circ\text{C}$	72	79		dB
		$-40^\circ\text{C} < T < 125^\circ\text{C}$	70			
$A_{vd}$	Large signal voltage gain ( $V_{out} = 0.5\text{ V}$ to $(V_{CC}-0.5\text{ V})$ )	$R_L = 10\text{ k}\Omega$ , $T = 25^\circ\text{C}$	100	110		dB
		$R_L = 10\text{ k}\Omega$ , $-40^\circ\text{C} < T < 125^\circ\text{C}$	90			
		$R_L = 2\text{ k}\Omega$ , $T = 25^\circ\text{C}$	90	100		
		$R_L = 2\text{ k}\Omega$ , $-40^\circ\text{C} < T < 125^\circ\text{C}$	80			
$V_{CC}-V_{OH}$	High level output voltage	$R_L = 10\text{ k}\Omega$ , $T = 25^\circ\text{C}$		10	100	mV
		$R_L = 10\text{ k}\Omega$ , $-40^\circ\text{C} < T < 125^\circ\text{C}$			200	
		$R_L = 2\text{ k}\Omega$ , $T = 25^\circ\text{C}$		40	300	
		$R_L = 2\text{ k}\Omega$ , $-40^\circ\text{C} < T < 125^\circ\text{C}$			400	
$V_{OL}$	Low level output voltage	$R_L = 10\text{ k}\Omega$ , $T = 25^\circ\text{C}$		65	180	mV
		$R_L = 10\text{ k}\Omega$ , $-40^\circ\text{C} < T < 125^\circ\text{C}$			280	
		$R_L = 2\text{ k}\Omega$ , $T = 25^\circ\text{C}$		120	300	
		$R_L = 2\text{ k}\Omega$ , $-40^\circ\text{C} < T < 125^\circ\text{C}$			400	
$I_{out}$	$I_{sink}$ ( $V_{out} = V_{CC}$ ) $V_{id} = -1\text{ V}$	$T = 25^\circ\text{C}$	35	43		mA
		$-40^\circ\text{C} < T < 125^\circ\text{C}$	25			
	$I_{source}$ ( $V_{out} = 0\text{ V}$ ) $V_{id} = 1\text{ V}$	$T = 25^\circ\text{C}$	60	70		mA
		$-40^\circ\text{C} < T < 125^\circ\text{C}$	50			
$I_{CC}$	Supply current (per channel) No load, $V_{out} = V_{CC}/2$	$T = 25^\circ\text{C}$		130	180	$\mu\text{A}$
		$-40^\circ\text{C} < T < 125^\circ\text{C}$			180	



**Table 6. Electrical characteristics at  $V_{CC+} = 5\text{ V}$  with  $V_{CC-} = 0\text{ V}$ ,  $V_{icm} = V_{CC}/2$ ,  $T_{amb} = 25^\circ\text{ C}$ , and  $R_L$  connected to  $V_{CC}/2$  (unless otherwise specified) (continued)**

Symbol	Parameter	Conditions	Min.	Typ.	Max.	Unit
<b>AC performance</b>						
GBP	Gain bandwidth product	$R_L > 1\text{ M}\Omega$ , $C_L = 200\text{ pF}$		1.3		MHz
$F_u$	Unity gain frequency	$R_L > 1\text{ M}\Omega$ , $C_L = 200\text{ pF}$		1		MHz
$\Phi_m$	Phase margin	$R_L > 1\text{ M}\Omega$ , $C_L = 200\text{ pF}$		60		degrees
$G_m$	Gain margin	$R_L > 1\text{ M}\Omega$ , $C_L = 200\text{ pF}$		10		dB
SR	Slew rate	$R_L > 1\text{ M}\Omega$ , $C_L = 200\text{ pF}$ $V_{out} = 0.5\text{ V to } V_{CC} - 0.5\text{ V}$		0.7		V/ $\mu\text{s}$
$e_n$	Equivalent input noise voltage	$f = 1\text{ kHz}$ $f = 10\text{ kHz}$		30 20		$\frac{\text{nV}}{\sqrt{\text{Hz}}}$
$i_n$	Equivalent input noise current	$f = 1\text{ kHz}$		0.30		$\frac{\text{pA}}{\sqrt{\text{Hz}}}$
THD+N	Total harmonic distortion + noise	$f_{in} = 1\text{ kHz}$ , $A_{CL} = 1$ , $R_L = 10\text{ k}\Omega$ , $V_{icm} = V_{CC}/2$ , $BW = 22\text{ kHz}$ , $V_{out} = 1\text{ V}_{pp}$		0.002		%

1. See [Chapter 4.4: Input offset voltage drift over temperature](#).

**Table 7. Shutdown characteristics  $V_{CC} = 5\text{ V}$**

Symbol	Parameter	Conditions	Min.	Typ.	Max.	Unit
<b>DC performance</b>						
$I_{CC}$	Supply current in shutdown mode (per channel)	$\overline{\text{SHDN}} = V_{CC-}$		2.5	50	nA
		$-40^\circ\text{C} < T < 85^\circ\text{C}$			200	nA
		$-40^\circ\text{C} < T < 125^\circ\text{C}$			1.5	$\mu\text{A}$
$t_{on}$	Amplifier turn-on time <sup>(1)</sup>	$R_L = 2\text{ k}\Omega$ , $V_{out} = V_{CC-}$ to $V_{CC+} + 0.2\text{ V}$		300		ns
$t_{off}$	Amplifier turn-off time <sup>(1)</sup>	$R_L = 2\text{ k}\Omega$ , $V_{out} = V_{CC+} - 1\text{ V}$ to $V_{CC+} - 1.2\text{ V}$		20		ns
$V_{IH}$	$\overline{\text{SHDN}}$ logic high		$V_{CC-}$ 0.5			V
$V_{IL}$	$\overline{\text{SHDN}}$ logic low				0.5	V
$I_{IH}$	$\overline{\text{SHDN}}$ current high	$\overline{\text{SHDN}} = V_{CC+}$		10		pA
$I_{IL}$	$\overline{\text{SHDN}}$ current low	$\overline{\text{SHDN}} = V_{CC-}$		10		pA
$I_{OLeak}$	Output leakage in shutdown mode	$\overline{\text{SHDN}} = V_{CC-}$		50		pA
		$-40^\circ\text{C} < T < 125^\circ\text{C}$		1		nA

1. See [Section 4.7: Shutdown function on page 15](#).

Figure 2. Supply current vs. supply voltage at  $V_{icm} = V_{CC}/2$

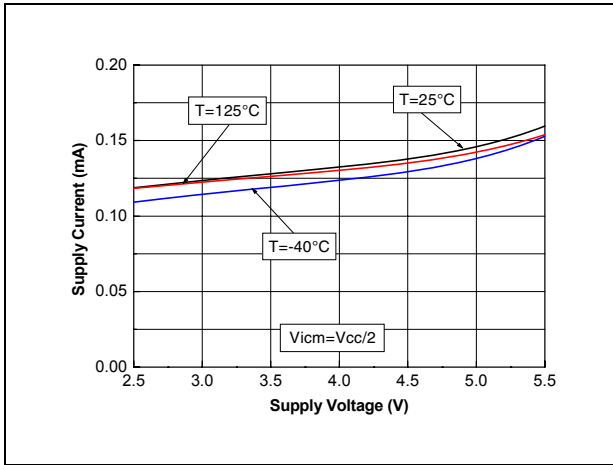

Figure 3. Vio distribution at  $V_{CC} = 5 V$

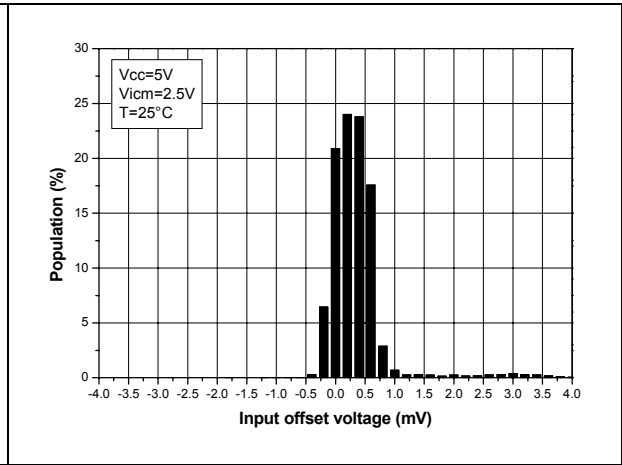

Figure 4. Input offset voltage vs. input common mode voltage at  $V_{CC} = 5 V$

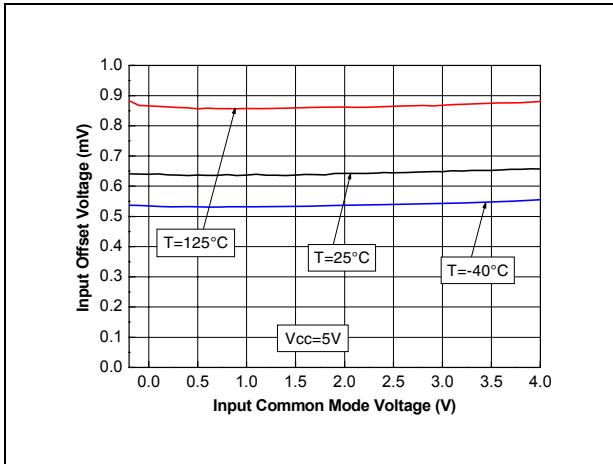

Figure 5. Output current vs. output voltage at  $V_{CC} = 2.7 V$

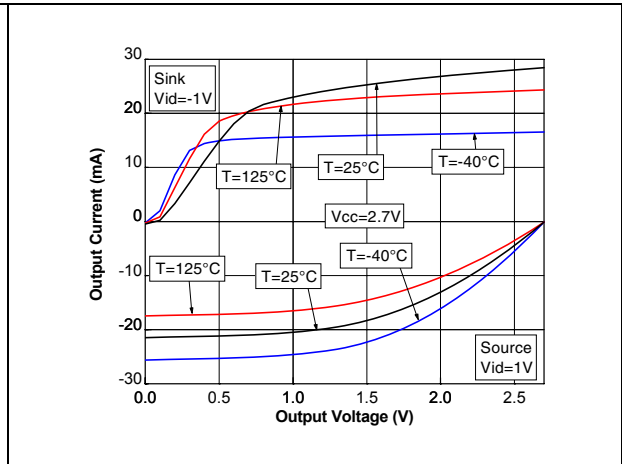

Figure 6. Output current vs. output voltage at  $V_{CC} = 5 V$

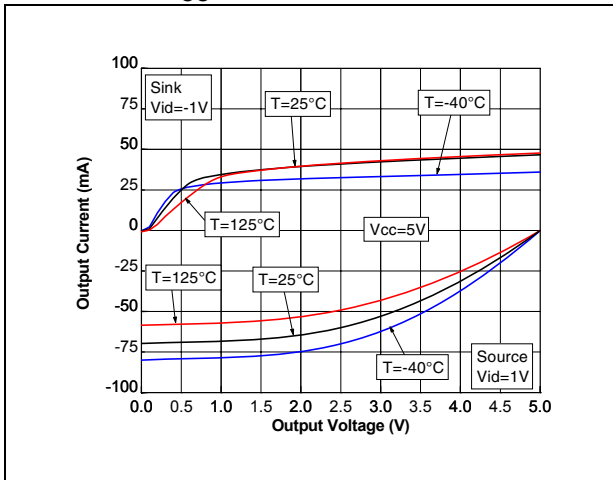

Figure 7. Output current vs. supply voltage at  $V_{icm} = V_{CC}/2$

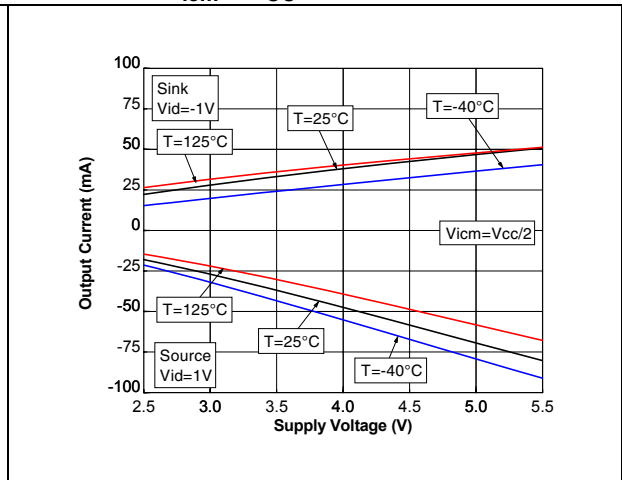

Figure 8. Voltage gain and phase with  $C_I = 100 \text{ pF}$

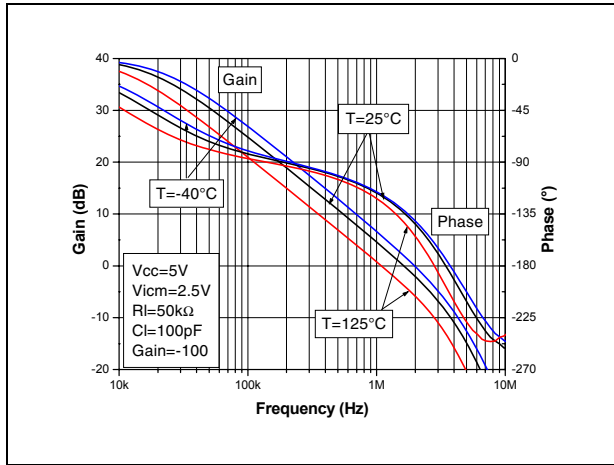

Figure 9. Voltage gain and phase with  $C_I = 200 \text{ pF}$

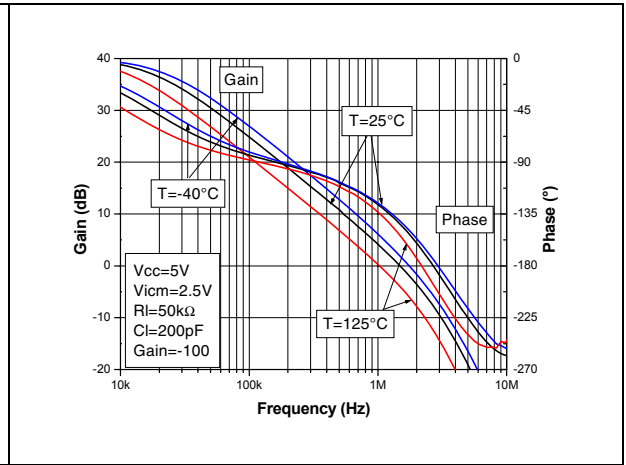

Figure 10. Gain margin vs. load capacitor at  $V_{CC} = 5 \text{ V}$

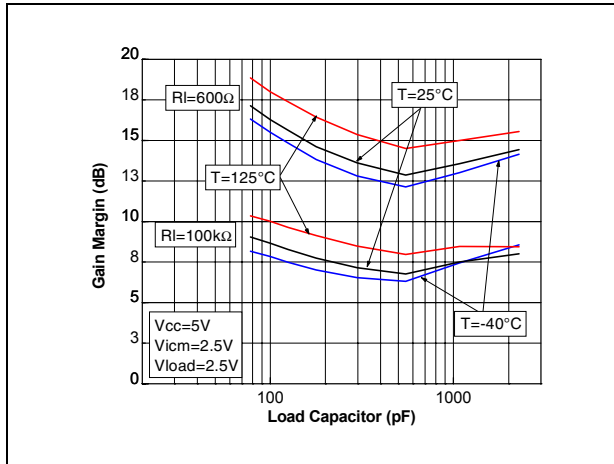
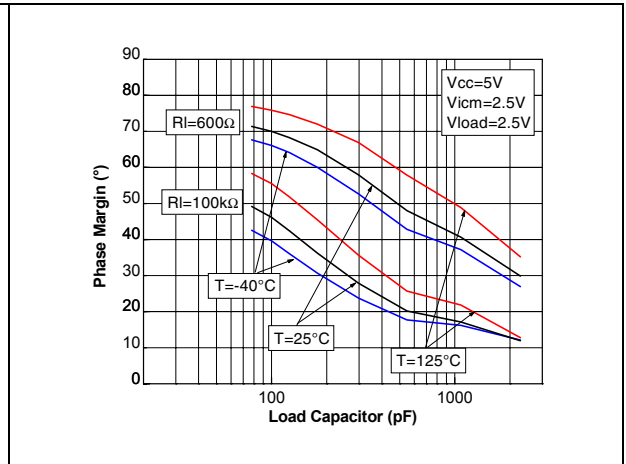
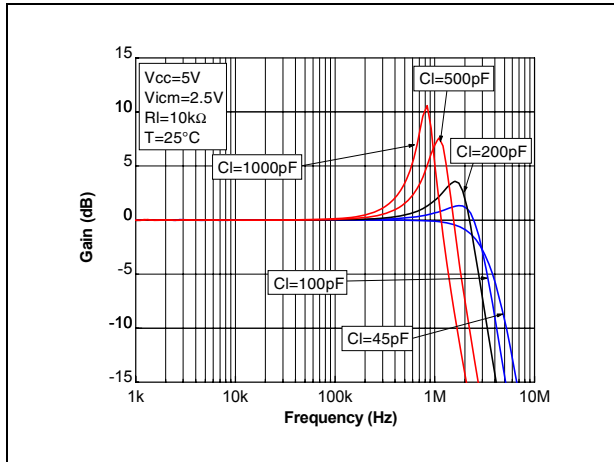

Figure 11. Phase margin vs. load capacitor at  $V_{CC} = 5 \text{ V}$



**Figure 12. Closed-loop gain in voltage follower configuration for different capacitive loads**



**Figure 13. Phase margin vs. output current at V<sub>CC</sub> = 5 V**

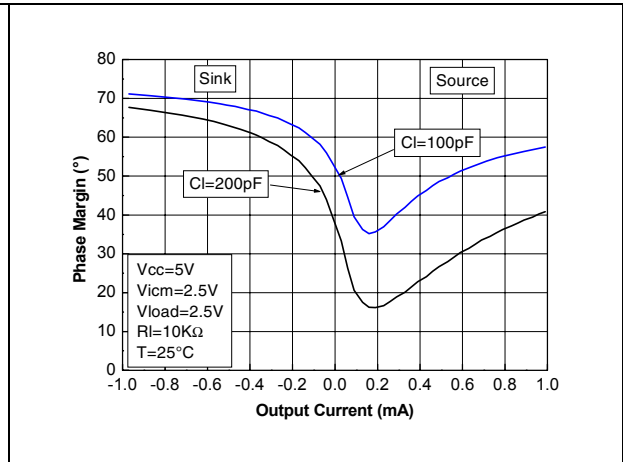

**Figure 14. Positive and negative slew rate vs. supply voltage**

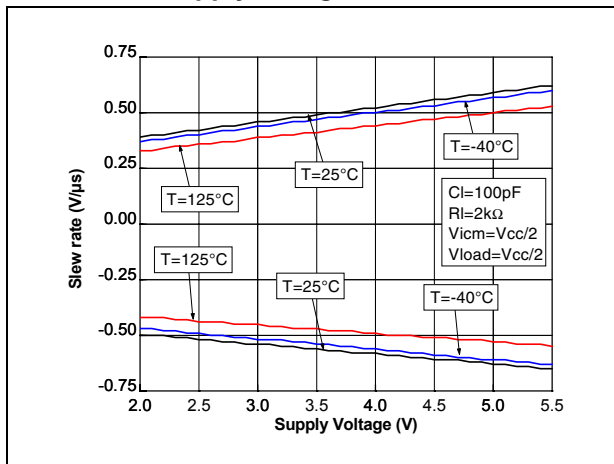

**Figure 15. Positive slew rate at V<sub>CC</sub> = 5 V with Cl = 100 pF**

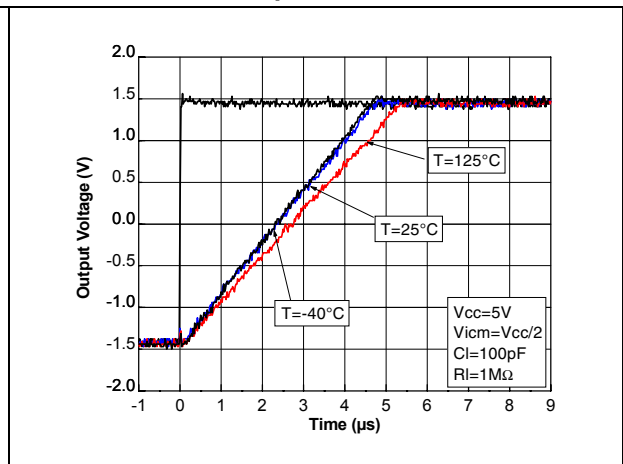

Figure 16. Negative slew rate at  $V_{CC} = 5\text{ V}$  with  $C_I = 100\text{ pF}$  Figure 17. Noise vs. frequency

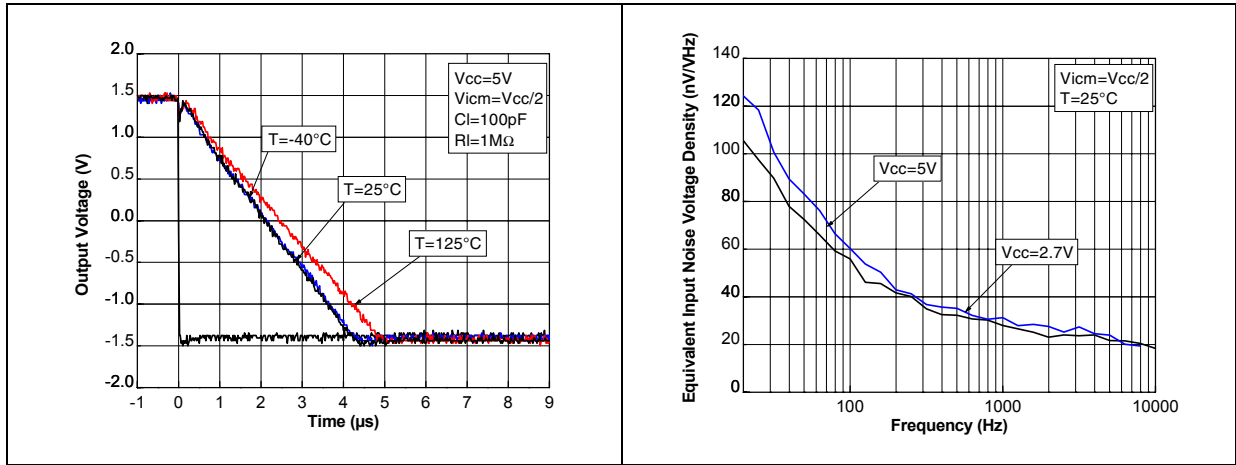

Figure 18. 0.1 Hz to 10 Hz noise at  $V_{CC} = 5\text{ V}$  Figure 19. Distortion + noise vs. frequency

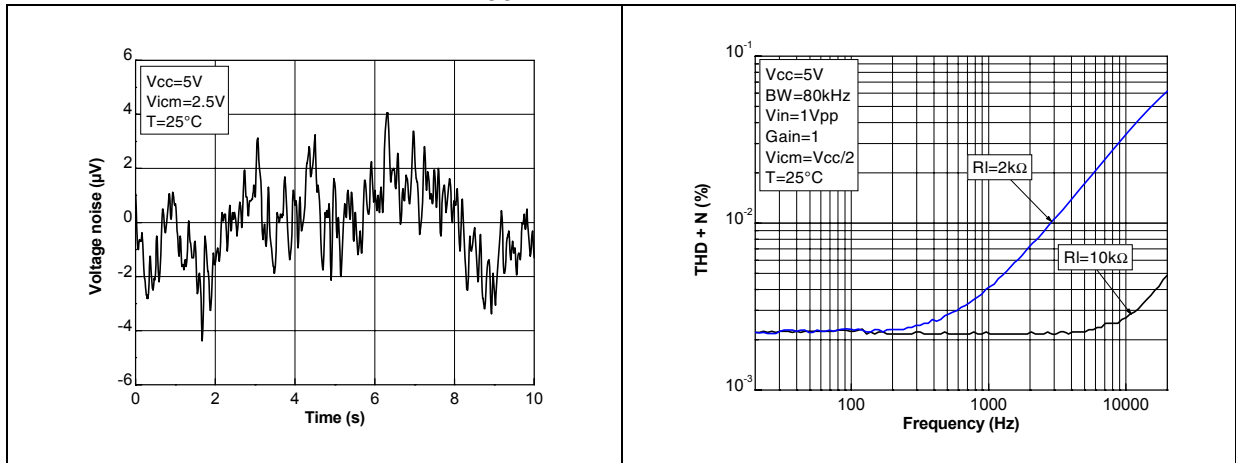
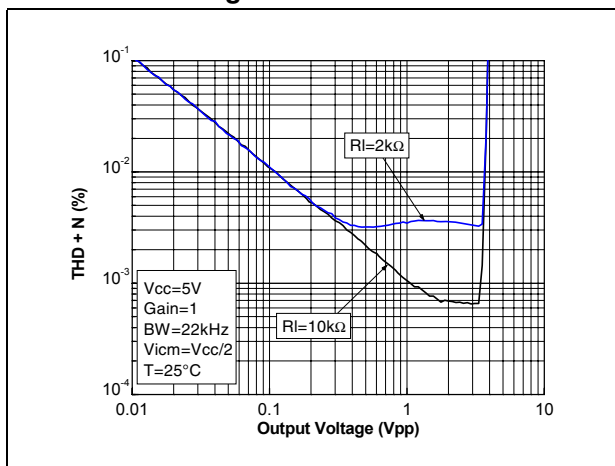

Figure 20. Distortion + noise vs. output voltage



## 4 Application information

### 4.1 Operating voltages

The TSV85x can operate from 2.5 to 5.5 V. The devices' parameters are fully specified for 2.7 and 5 V power supplies. Additionally, the main specifications are guaranteed in extended temperature ranges from -40° C to +125° C.

### 4.2 Input common-mode range

The TSV85x have an input common-mode range that includes ground. The input common-mode range is extended from  $V_{CC-} - 0.2$  V to  $V_{CC+} - 1$  V, with no output phase reversal.

### 4.3 Rail-to-rail output

The operational amplifiers' output levels can go close to the rails: 180 mV maximum above and below the rail when connected to a 10 k $\Omega$  resistive load to  $V_{CC}/2$ .

### 4.4 Input offset voltage drift over temperature

The maximum input voltage drift over the temperature variation is defined as follows.

$$\frac{\Delta V_{io}}{\Delta T} = \max \left| \frac{V_{io}(T) - V_{io}(25^\circ \text{C})}{T - 25^\circ \text{C}} \right|$$

for  $T_{\min} < T < T_{\max}$ .

### 4.5 PCB layouts

For correct operation, it is advised to add 10 nF decoupling capacitors as close as possible to the power supply pins.

### 4.6 Macromodel

Accurate macromodels of the TSV85x are available on STMicroelectronics' web site at [www.st.com](http://www.st.com). This model is a trade-off between accuracy and complexity (that is, time simulation) of the TSV85x operational amplifiers. It emulates the nominal performances of a typical device within the specified operating conditions mentioned in the datasheet. It also helps to validate a design approach and to select the right operational amplifier, *but it does not replace on-board measurements*.

### 4.7 Shutdown function

The operational amplifier is enabled when the  $\overline{\text{SHDN}}$  pin is pulled high. To disable the amplifier, the  $\overline{\text{SHDN}}$  pin must be pulled down to  $V_{CC-}$ . When in shutdown mode, the amplifier output is in a high impedance state. The  $\overline{\text{SHDN}}$  pin must never be left floating but tied to  $V_{CC+}$  or  $V_{CC-}$ .

The turn-on and turn-off times are calculated for an output variation of  $\pm 200$  mV (Figure 21 and Figure 22 show the test configurations).

Figure 21. Test configuration for turn-on time (Vout pulled down)

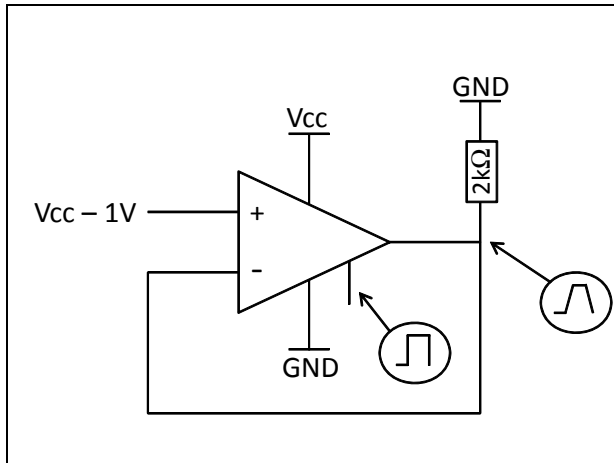

Figure 22. Test configuration for turn-off time (Vout pulled down)

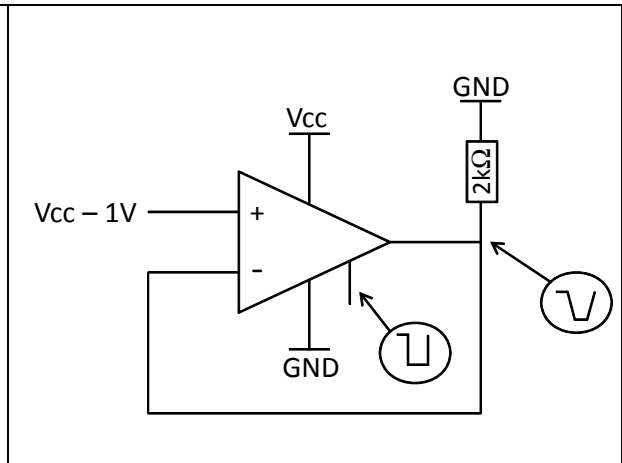

Figure 23. Turn-on time,  $V_{CC} = 5$  V, Vout pulled down,  $T = 25^\circ$  C

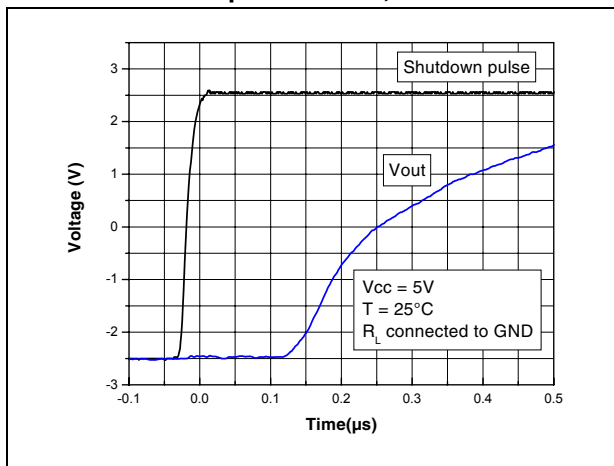
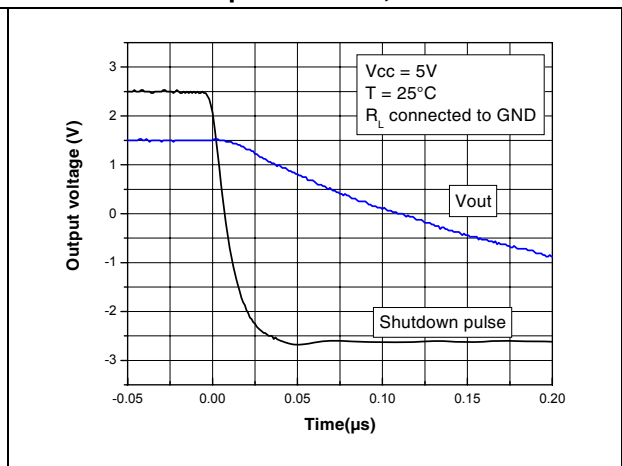

Figure 24. Turn-off time,  $V_{CC} = 5$  V, Vout pulled down,  $T = 25^\circ$  C



## 5 Package information

In order to meet environmental requirements, ST offers these devices in different grades of ECOPACK<sup>®</sup> packages, depending on their level of environmental compliance. ECOPACK<sup>®</sup> specifications, grade definitions and product status are available at: [www.st.com](http://www.st.com). ECOPACK<sup>®</sup> is an ST trademark.



### 5.1 SO-8 package information

Figure 25. SO-8 package mechanical drawing

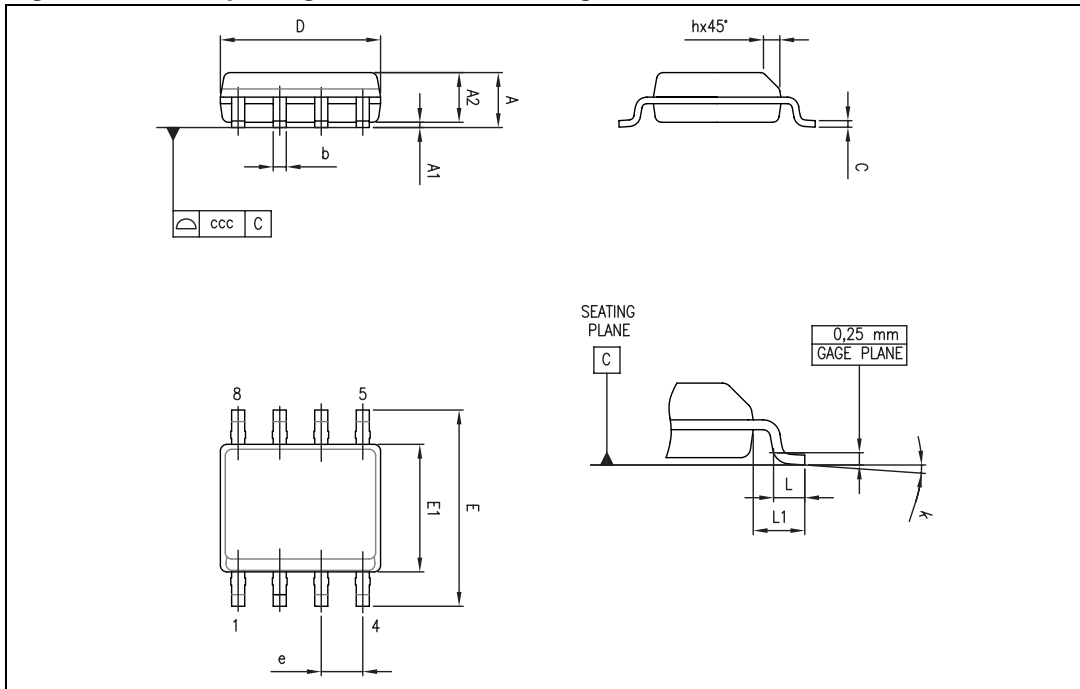

Table 8. SO-8 package mechanical data

Ref.	Dimensions					
	Millimeters			Inches		
	Min.	Typ.	Max.	Min.	Typ.	Max.
A			1.75			0.069
A1	0.10		0.25	0.004		0.010
A2	1.25			0.049		
b	0.28		0.48	0.011		0.019
c	0.17		0.23	0.007		0.010
D	4.80	4.90	5.00	0.189	0.193	0.197
E	5.80	6.00	6.20	0.228	0.236	0.244
E1	3.80	3.90	4.00	0.150	0.154	0.157
e		1.27			0.050	
h	0.25		0.50	0.010		0.020
L	0.40		1.27	0.016		0.050
L1		1.04			0.040	
k	1°		8°	1°		8°
ccc			0.10			0.004

## 5.2 SO-14 package information

Figure 26. SO-14 package mechanical drawing

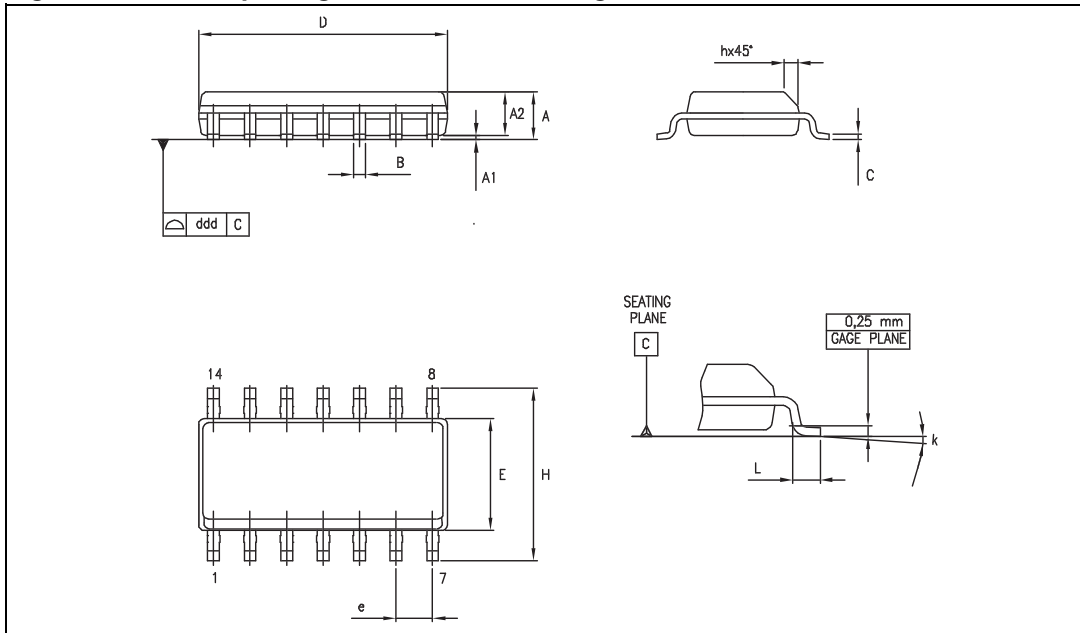

Table 9. SO-14 package mechanical data

Dimensions						
Ref.	Millimeters			Inches		
	Min.	Typ.	Max.	Min.	Typ.	Max.
A	1.35		1.75	0.05		0.068
A1	0.10		0.25	0.004		0.009
A2	1.10		1.65	0.04		0.06
B	0.33		0.51	0.01		0.02
C	0.19		0.25	0.007		0.009
D	8.55		8.75	0.33		0.34
E	3.80		4.0	0.15		0.15
e		1.27			0.05	
H	5.80		6.20	0.22		0.24
h	0.25		0.50	0.009		0.02
L	0.40		1.27	0.015		0.05
k	8° (max.)					
ddd			0.10			0.004

### 5.3 TSSOP14 package information

Figure 27. TSSOP14 package mechanical drawing

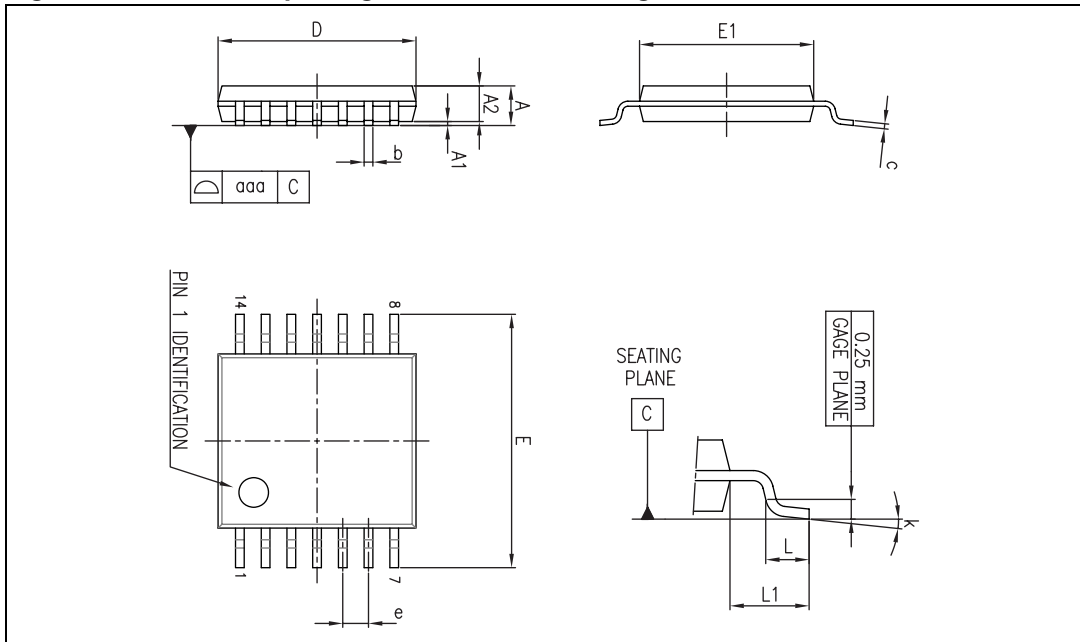

Table 10. TSSOP14 package mechanical data

Ref.	Dimensions					
	Millimeters			Inches		
	Min.	Typ.	Max.	Min.	Typ.	Max.
A			1.20			0.047
A1	0.05		0.15	0.002	0.004	0.006
A2	0.80	1.00	1.05	0.031	0.039	0.041
b	0.19		0.30	0.007		0.012
c	0.09		0.20	0.004		0.0089
D	4.90	5.00	5.10	0.193	0.197	0.201
E	6.20	6.40	6.60	0.244	0.252	0.260
E1	4.30	4.40	4.50	0.169	0.173	0.176
e		0.65			0.0256	
L	0.45	0.60	0.75	0.018	0.024	0.030
L1		1.00			0.039	
k	0°		8°	0°		8°
aaa			0.10			0.004

### 5.4 TSSOP16 package information

Figure 28. TSSOP16 package mechanical drawing

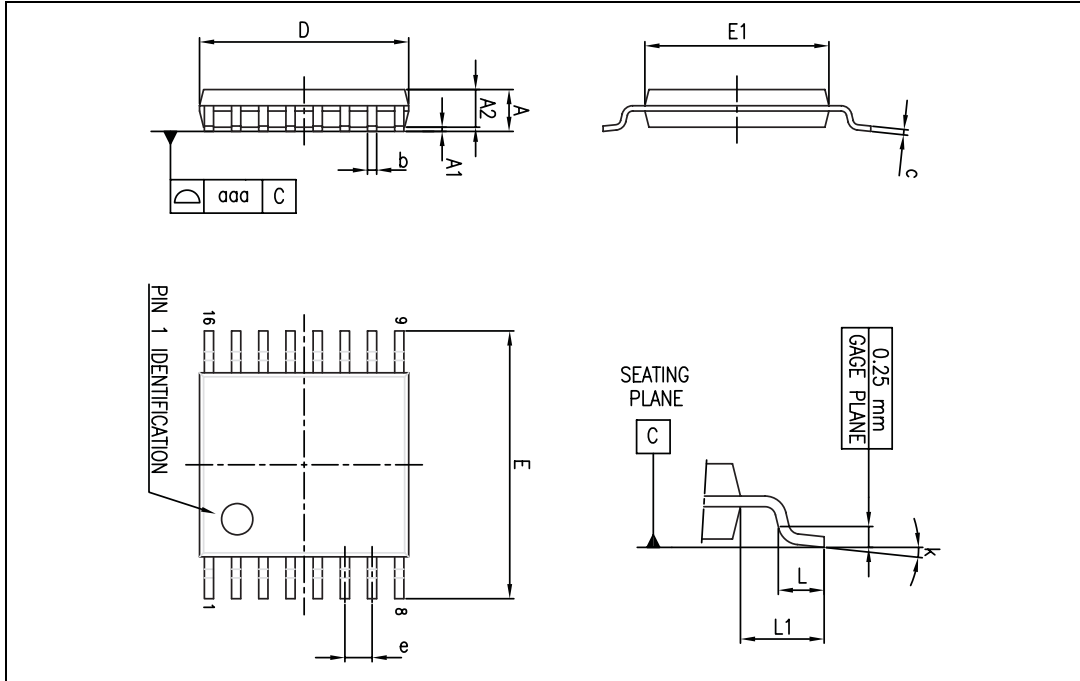

Table 11. TSSOP16 package mechanical data

Ref.	Dimensions					
	Millimeters			Inches		
	Min.	Typ.	Max.	Min.	Typ.	Max.
A			1.20			0.047
A1	0.05		0.15	0.002		0.006
A2	0.80	1.00	1.05	0.031	0.039	0.041
b	0.19		0.30	0.007		0.012
c	0.09		0.20	0.004		0.008
D	4.90	5.00	5.10	0.193	0.197	0.201
E	6.20	6.40	6.60	0.244	0.252	0.260
E1	4.30	4.40	4.50	0.169	0.173	0.177
e		0.65			0.0256	
k	0°		8°	0°		8°
L	0.45	0.60	0.75	0.018	0.024	0.030
L1		1.00			0.039	
aaa			0.10			0.004

### 5.5 MiniSO-8 package information

Figure 29. MiniSO-8 package mechanical drawing

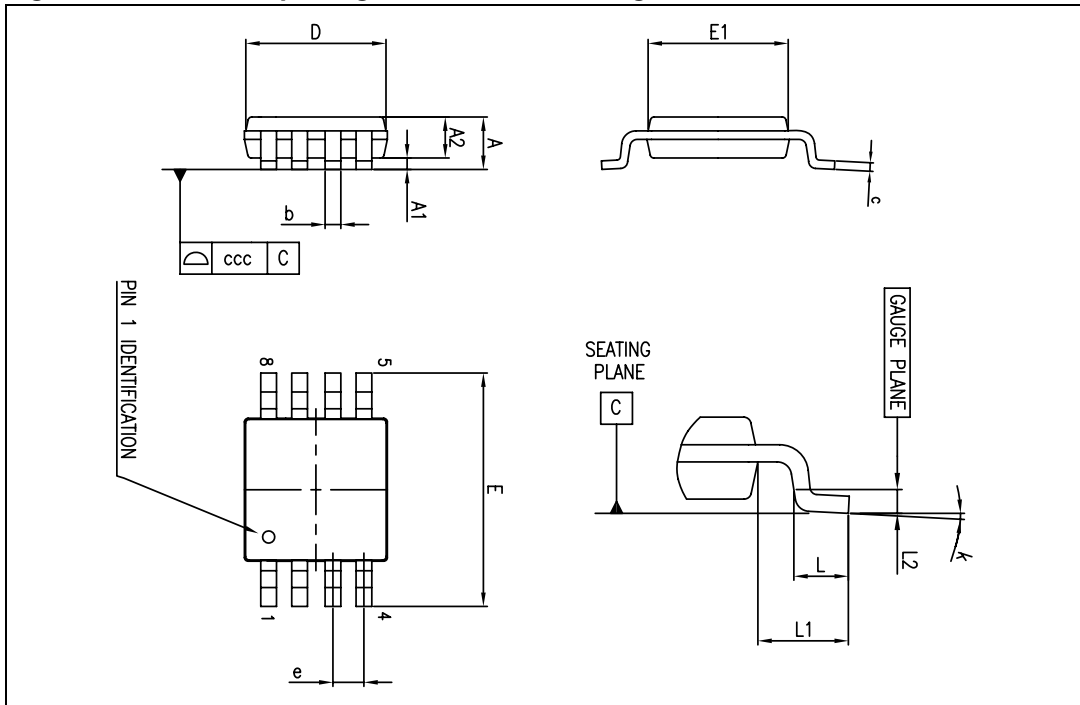

Table 12. MiniSO-8 package mechanical data

Ref.	Dimensions					
	Millimeters			Inches		
	Min.	Typ.	Max.	Min.	Typ.	Max.
A			1.1			0.043
A1	0		0.15	0		0.006
A2	0.75	0.85	0.95	0.030	0.033	0.037
b	0.22		0.40	0.009		0.016
c	0.08		0.23	0.003		0.009
D	2.80	3.00	3.20	0.11	0.118	0.126
E	4.65	4.90	5.15	0.183	0.193	0.203
E1	2.80	3.00	3.10	0.11	0.118	0.122
e		0.65			0.026	
L	0.40	0.60	0.80	0.016	0.024	0.031
L1		0.95			0.037	
L2		0.25			0.010	
k	0°		8°	0°		8°
ccc			0.10			0.004

### 5.6 MiniSO-10 package information

Figure 30. MiniSO-10 package mechanical drawing

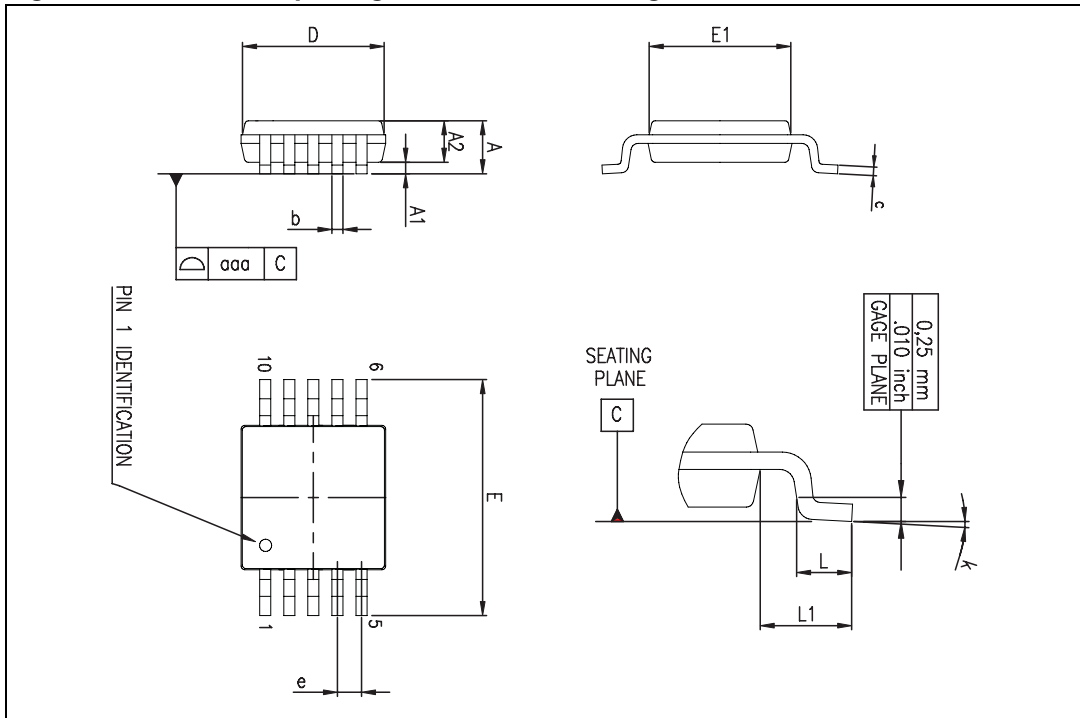

Table 13. MiniSO-10 package mechanical data

Ref.	Dimensions					
	Millimeters			Inches		
	Min.	Typ.	Max.	Min.	Typ.	Max.
A			1.10			0.043
A1	0.05	0.10	0.15	0.002	0.004	0.006
A2	0.78	0.86	0.94	0.031	0.034	0.037
b	0.25	0.33	0.40	0.010	0.013	0.016
c	0.15	0.23	0.30	0.006	0.009	0.012
D	2.90	3.00	3.10	0.114	0.118	0.122
E	4.75	4.90	5.05	0.187	0.193	0.199
E1	2.90	3.00	3.10	0.114	0.118	0.122
e		0.50			0.020	
L	0.40	0.55	0.70	0.016	0.022	0.028
L1		0.95			0.037	
k	0°	3°	6°	0°	3°	6°
aaa			0.10			0.004

### 5.7 DFN8 package information

Figure 31. DFN8 2 x 2 mm package mechanical drawing (pitch 0.5 mm)

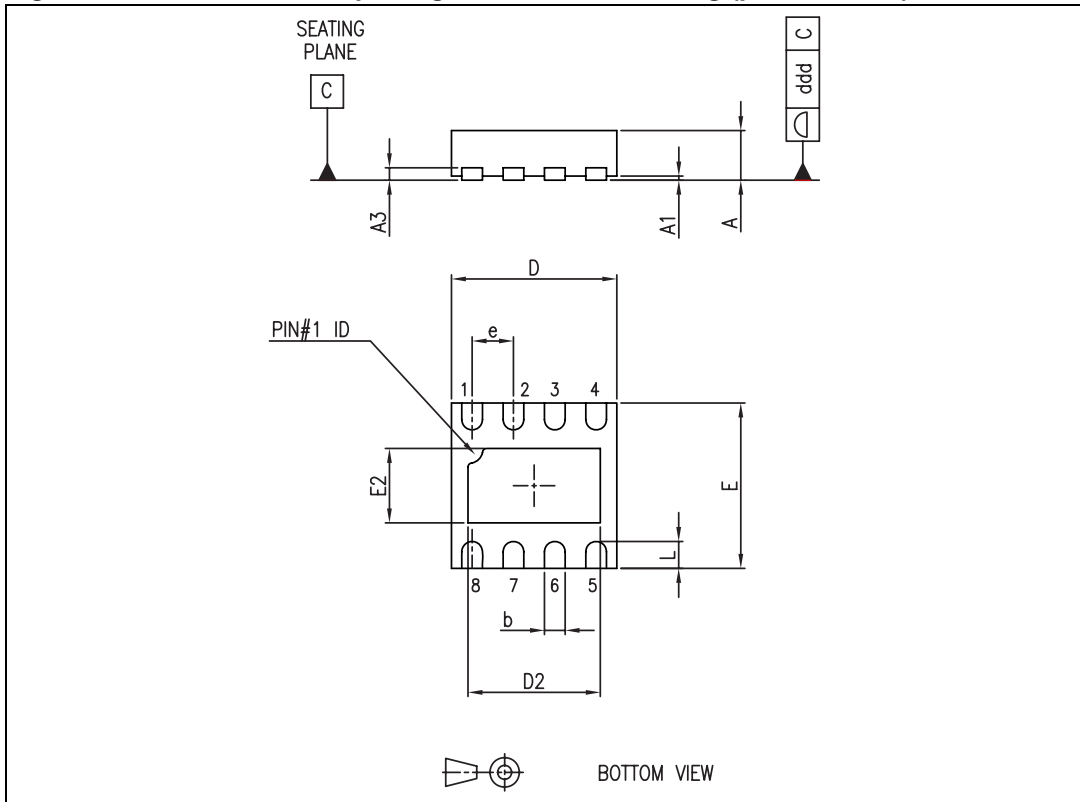

Table 14. DFN8 2 x 2 mm package mechanical data (pitch 0.5 mm)

Ref.	Dimensions					
	Millimeters			Inches		
	Min.	Typ.	Max.	Min.	Typ.	Max.
A	0.51	0.55	0.60	0.020	0.022	0.024
A1			0.05			0.002
A3		0.15			0.006	
b	0.18	0.25	0.30	0.007	0.010	0.012
D	1.85	2.00	2.15	0.073	0.079	0.085
D2	1.45	1.60	1.70	0.057	0.063	0.067
E	1.85	2.00	2.15	0.073	0.079	0.085
E2	0.75	0.90	1.00	0.030	0.035	0.040
e		0.50			0.020	
L			0.50			0.020
ddd			0.08			0.003

### 5.8 SOT23-5 package information

Figure 32. SOT23-5L package mechanical drawing

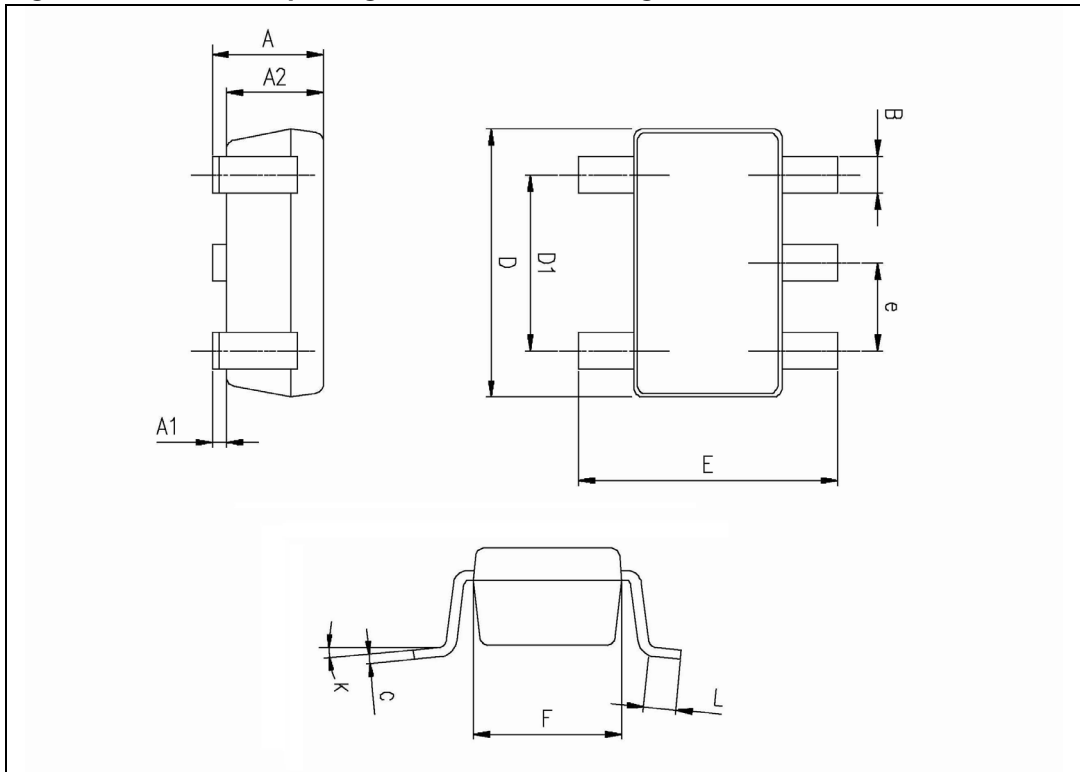

Table 15. SOT23-5L package mechanical data

Ref.	Dimensions					
	Millimeters			Inches		
	Min.	Typ.	Max.	Min.	Typ.	Max.
A	0.90	1.20	1.45	0.035	0.047	0.057
A1			0.15			0.006
A2	0.90	1.05	1.30	0.035	0.041	0.051
B	0.35	0.40	0.50	0.013	0.015	0.019
C	0.09	0.15	0.20	0.003	0.006	0.008
D	2.80	2.90	3.00	0.110	0.114	0.118
D1		1.90			0.075	
e		0.95			0.037	
E	2.60	2.80	3.00	0.102	0.110	0.118
F	1.50	1.60	1.75	0.059	0.063	0.069
L	0.10	0.35	0.60	0.004	0.013	0.023
K	0 degrees		10 degrees			



## 5.9 SOT23-6 package information

Figure 33. SOT23-6L package mechanical drawing

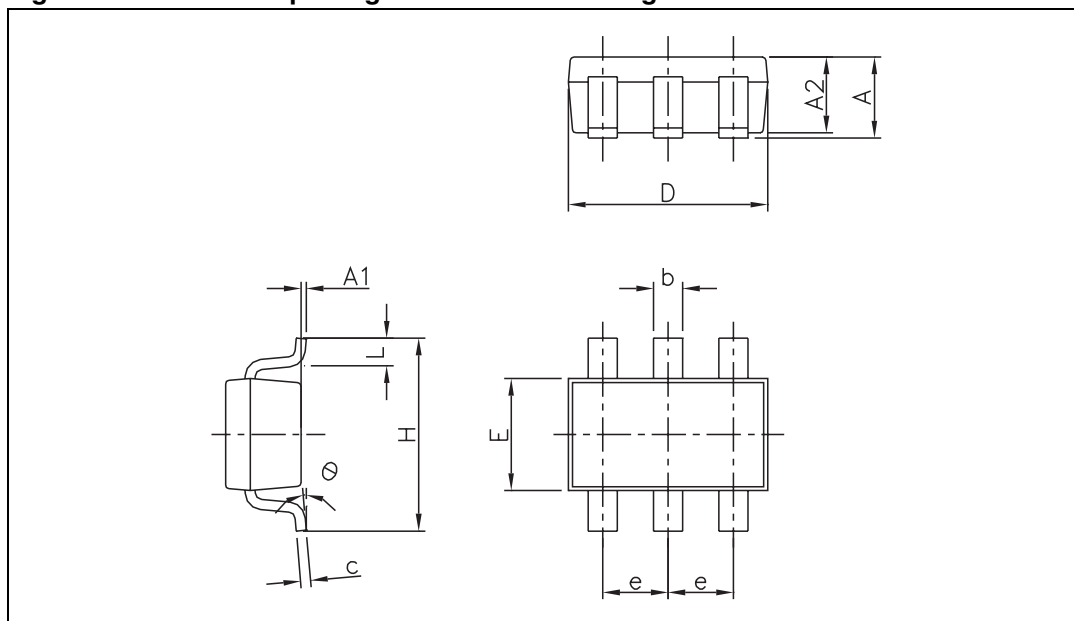

Table 16. SOT23-6L package mechanical data

Ref.	Dimensions					
	Millimeters			Inches		
	Min.	Typ.	Max.	Min.	Typ.	Max.
A	0.90		1.45	0.035		0.057
A1			0.10			0.004
A2	0.90		1.30	0.035		0.051
b	0.35		0.50	0.013		0.019
c	0.09		0.20	0.003		0.008
D	2.80		3.05	0.110		0.120
E	1.50		1.75	0.060		0.069
e		0.95			0.037	
H	2.60		3.00	0.102		0.118
L	0.10		0.60	0.004		0.024
°	0		10°			

### 5.10 SC70-5 (or SOT323-5) package information

Figure 34. SC70-5 (or SOT323-5) package mechanical drawing

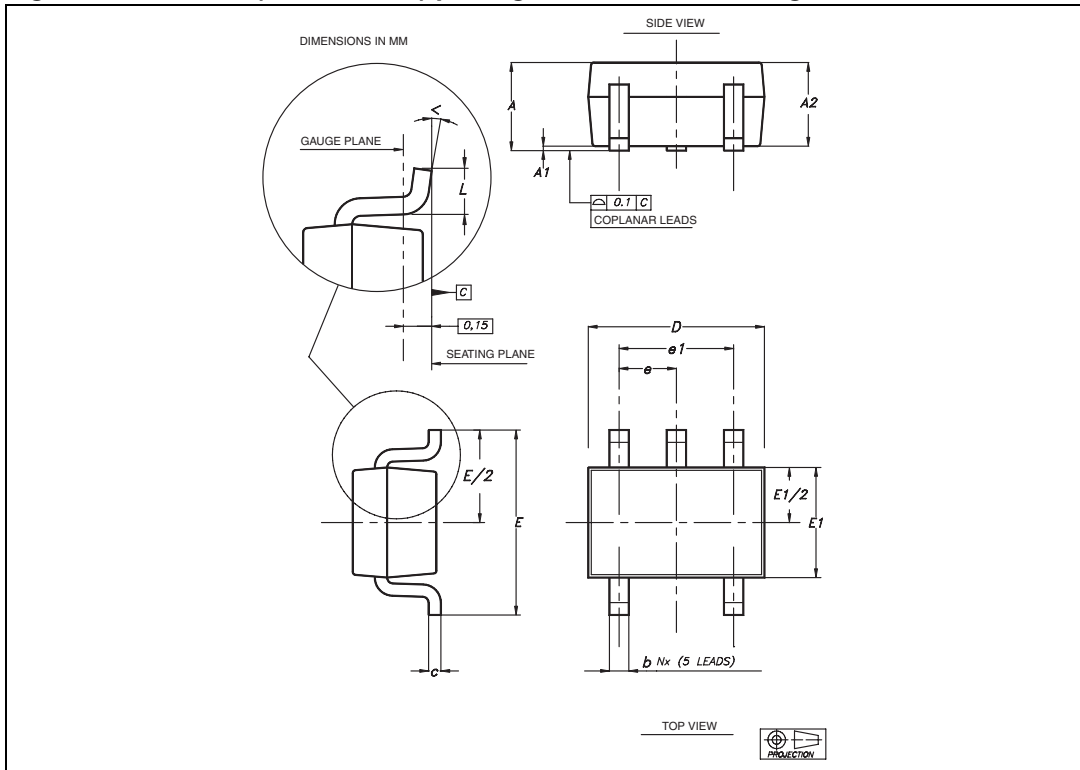

Table 17. SC70-5 (or SOT323-5) package mechanical data

Ref	Dimensions					
	Millimeters			Inches		
	Min	Typ	Max	Min	Typ	Max
A	0.80		1.10	0.032		0.043
A1			0.10			0.004
A2	0.80	0.90	1.00	0.032	0.035	0.039
b	0.15		0.30	0.006		0.012
c	0.10		0.22	0.004		0.009
D	1.80	2.00	2.20	0.071	0.079	0.087
E	1.80	2.10	2.40	0.071	0.083	0.094
E1	1.15	1.25	1.35	0.045	0.049	0.053
e		0.65			0.025	
e1		1.30			0.051	
L	0.26	0.36	0.46	0.010	0.014	0.018
<	0°		8°			

## 6 Ordering information

**Table 18. Order codes for devices without shutdown feature**

Order code	Temperature range	Package	Packing	Marking
TSV851ICT	-40° C to +125° C	SC70-5	Tape & reel	K5E
TSV851ILT		SOT23-5		K153
TSV852IQ2T		DFN8 2x2		K5E
TSV852IST		MiniSO8		K153
TSV852IDT		SO8		TSV852I
TSV854IPT		TSSOP14		TSV854I
TSV854IDT		SO14		TSV854I
TSV851AICT	-40° C to +125° C	SC70-5	Tape & reel	K5F
TSV851AILT		SOT23-5		K154
TSV852AIST		MiniSO8		K154
TSV852AIDT		SO8		TSV852AI
TSV854AIPT		TSSOP14		TSV854AI
TSV854AIDT		SO14		TSV854AI

**Table 19. Order codes for devices with shutdown feature**

Order code	Temperature range	Package	Packing	Marking
TSV850ILT	-40° C to +125° C	SOT23-6	Tape & reel	K153
TSV853IST		MiniSO10		K153
TSV855IPT		TSSOP16		TSV855I
TSV850AILT	-40° C to +125° C	SOT23-6	Tape & reel	K154
TSV853AIST		MiniSO10		K154
TSV855AIPT		TSSOP16		TSV855AI

## 7 Revision history

Table 20. Document revision history

Date	Revision	Changes
10-Nov-2011	1	Initial release.

**Please Read Carefully:**

Information in this document is provided solely in connection with ST products. STMicroelectronics NV and its subsidiaries ("ST") reserve the right to make changes, corrections, modifications or improvements, to this document, and the products and services described herein at any time, without notice.

All ST products are sold pursuant to ST's terms and conditions of sale.

Purchasers are solely responsible for the choice, selection and use of the ST products and services described herein, and ST assumes no liability whatsoever relating to the choice, selection or use of the ST products and services described herein.

No license, express or implied, by estoppel or otherwise, to any intellectual property rights is granted under this document. If any part of this document refers to any third party products or services it shall not be deemed a license grant by ST for the use of such third party products or services, or any intellectual property contained therein or considered as a warranty covering the use in any manner whatsoever of such third party products or services or any intellectual property contained therein.

**UNLESS OTHERWISE SET FORTH IN ST'S TERMS AND CONDITIONS OF SALE ST DISCLAIMS ANY EXPRESS OR IMPLIED WARRANTY WITH RESPECT TO THE USE AND/OR SALE OF ST PRODUCTS INCLUDING WITHOUT LIMITATION IMPLIED WARRANTIES OF MERCHANTABILITY, FITNESS FOR A PARTICULAR PURPOSE (AND THEIR EQUIVALENTS UNDER THE LAWS OF ANY JURISDICTION), OR INFRINGEMENT OF ANY PATENT, COPYRIGHT OR OTHER INTELLECTUAL PROPERTY RIGHT.**

**UNLESS EXPRESSLY APPROVED IN WRITING BY TWO AUTHORIZED ST REPRESENTATIVES, ST PRODUCTS ARE NOT RECOMMENDED, AUTHORIZED OR WARRANTED FOR USE IN MILITARY, AIR CRAFT, SPACE, LIFE SAVING, OR LIFE SUSTAINING APPLICATIONS, NOR IN PRODUCTS OR SYSTEMS WHERE FAILURE OR MALFUNCTION MAY RESULT IN PERSONAL INJURY, DEATH, OR SEVERE PROPERTY OR ENVIRONMENTAL DAMAGE. ST PRODUCTS WHICH ARE NOT SPECIFIED AS "AUTOMOTIVE GRADE" MAY ONLY BE USED IN AUTOMOTIVE APPLICATIONS AT USER'S OWN RISK.**

Resale of ST products with provisions different from the statements and/or technical features set forth in this document shall immediately void any warranty granted by ST for the ST product or service described herein and shall not create or extend in any manner whatsoever, any liability of ST.

ST and the ST logo are trademarks or registered trademarks of ST in various countries.

Information in this document supersedes and replaces all information previously supplied.

The ST logo is a registered trademark of STMicroelectronics. All other names are the property of their respective owners.

© 2011 STMicroelectronics - All rights reserved

STMicroelectronics group of companies

Australia - Belgium - Brazil - Canada - China - Czech Republic - Finland - France - Germany - Hong Kong - India - Israel - Italy - Japan - Malaysia - Malta - Morocco - Philippines - Singapore - Spain - Sweden - Switzerland - United Kingdom - United States of America

[www.st.com](http://www.st.com)