

■ Features :

- AC input range selectable by switch
- Built-in passive PFC function compliance to EN61000-3-2
- High efficiency 89% and low dissipation
- Protections: Short circuit / Overload / Over voltage / Over temperature
- Cooling by free air convection
- Built-in constant current limiting circuit
- Can be installed on DIN rail TS-35/7.5 or 15
- UL 508(industrial control equipment)approved
- EN61000-6-2(EN50082-2) industrial immunity level
- 100% full load burn-in test
- 3 years warranty

SPECIFICATION

MODEL	DRP-480S-24	DRP-480S-48	
OUTPUT	DC VOLTAGE	24V	48V
	RATED CURRENT	20A	10A
	CURRENT RANGE	0 ~ 20A	0 ~ 10A
	RATED POWER	480W	480W
	RIPPLE & NOISE (max.) Note.2	120mVp-p	120mVp-p
	VOLTAGE ADJ. RANGE	24 ~ 28V	48 ~ 55V
	VOLTAGE TOLERANCE Note.3	±1.0%	±1.0%
	LINE REGULATION	±0.5%	±0.5%
	LOAD REGULATION	±1.0%	±1.0%
	SETUP, RISE TIME	1200ms, 40ms/230VAC,115VAC at full load	
HOLD UP TIME (Typ.)	23ms/230VAC,115VAC at full load		
INPUT	VOLTAGE RANGE	90 ~ 132VAC/180 ~ 264VAC by switch	254 ~ 370VDC
	FREQUENCY RANGE	47 ~ 63Hz	
	POWER FACTOR (Typ.)	≥ 0.7/230VAC only	
	EFFICIENCY (Typ.)	89%	
	AC CURRENT (Typ.)	8A/115VAC	3.2A/230VAC
	INRUSH CURRENT (Typ.)	COLD START 27A/115VAC	45A/230VAC
LEAKAGE CURRENT	<3.5mA / 240VAC		
PROTECTION	OVERLOAD	105 ~ 150% rated output power Protection type : Constant current limiting, recovers automatically after fault condition is removed	
	OVER VOLTAGE	30 ~ 36V	59 ~66V Protection type : Shut down o/p voltage, re-power on to recover
	OVER TEMPERATURE	100°C ±5°C (TSW : detect on heatsink of power switch) Protection type : Shut down o/p voltage, recovers automatically after temperature goes down	
ENVIRONMENT	WORKING TEMP.	-20 ~ +70°C (Refer to "Derating Curve")	
	WORKING HUMIDITY	20 ~ 90% RH non-condensing	
	STORAGE TEMP., HUMIDITY	-40 ~ +85°C, 10 ~ 95% RH	
	TEMP. COEFFICIENT	±0.03%/°C (0 ~ 50°C)	
VIBRATION	Component:10 ~ 500Hz, 2G 10min./1cycle, 60min. each along X, Y, Z axes; Mounting: Compliance to IEC60068-2-6		
SAFETY & EMC (Note 4)	SAFETY STANDARDS	UL508, UL60950-1, TUV EN60950-1 approved	
	WITHSTAND VOLTAGE	I/P-O/P:3KVAC	I/P-FG:1.5KVAC O/P-FG:0.5KVAC
	ISOLATION RESISTANCE	I/P-O/P, I/P-FG, O/P-FG:100M Ohms / 500VDC / 25°C / 70% RH	
	EMC EMISSION	Compliance to EN55011 (CISPR11), EN55022 (CISPR22), EN61204-3 Class B, EN61000-3-2,-3	
	EMC IMMUNITY	Compliance to EN61000-4-2,3,4,5,6,8,11, EN61204-3, EN61000-6-2 (EN50082-2), heavy industry level, criteria A	
OTHERS	MTBF	187.9Khrs min. MIL-HDBK-217F (25°C)	
	DIMENSION	227*125.2*100mm (W*H*D)	
	PACKING	2.6Kg; 6pcs / 16.6Kg / 1.75CUFT	
NOTE	1. All parameters NOT specially mentioned are measured at 230VAC input, rated load and 25°C of ambient temperature. 2. Ripple & noise are measured at 20MHz of bandwidth by using a 12" twisted pair-wire terminated with a 0.1uf & 47uf parallel capacitor. 3. Tolerance : includes set up tolerance, line regulation and load regulation. 4. The power supply is considered a component which will be installed into a final equipment. The final equipment must be re-confirmed that it still meets EMC directives.		

Mechanical Specification

Case No.930 Unit:mm

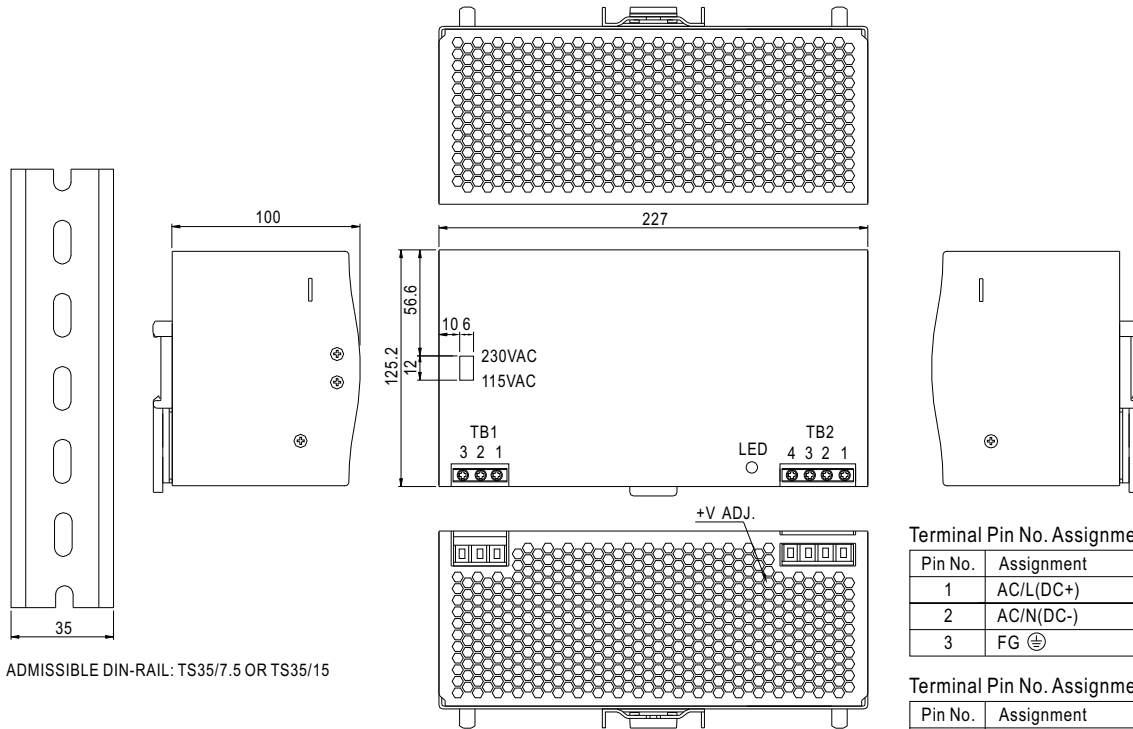

Block Diagram

fosc : 70KHz

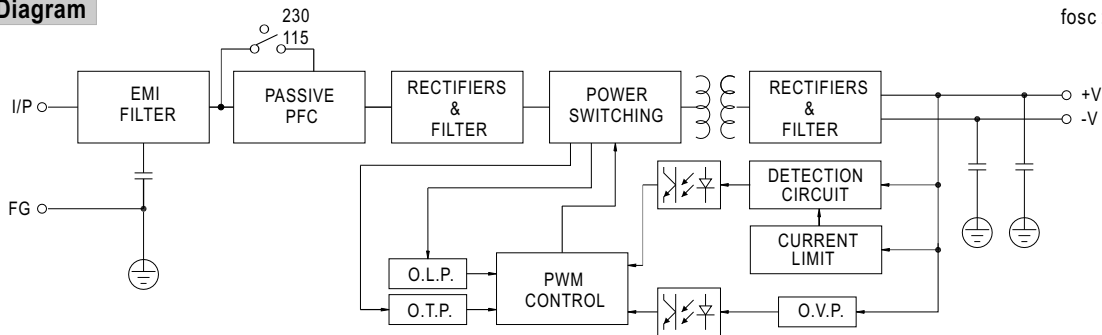

Derating Curve

Output Derating VS Input Voltage

