

Features

- Optocoupler, precision reference and error amplifier in single package
- Low voltage operation 2.7V
- 1.240V \pm 2.5% reference
- CTR Matching 15%
- >70dB THD
- 70dB CMRR
- 3,750V_{rms} isolation
- UL approval pending

Applications

- Power supply feedback
- Telecom central office supply
- Telecom bricks
- Modem transformer replacement
- Digital telephone isolation

Description

The LIA120 Optically Isolated Reference Amplifier combines Clare’s linear optical coupler technology with an industry standard 431 type precision programmable shunt regulator to provide very linear high gain with excellent temperature stability for a total gain error of less than 2dB. By using optical feedback, the LIA120 essentially eliminates temperature and gain variations due to current transfer ratio (CTR) changes in optocouplers while increasing the bandwidth up to 10X and easing engineering design constraints.

The LIA120 is very well suited for high gain feedback amplifiers that require excellent linearity and low temperature variation such as isolated power supply feedback stages, modem audio transformer replacement, isolated industrial control signals, and sensor feedback.

By using the LIA120, system designers can save precious board space and reduce component count. Available in an 8 pin surface mount package.

Block Diagram

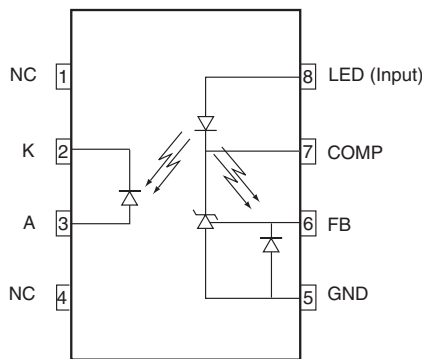

Ordering Information

Part #	Description
LIA120S	8 Pin Surface Mount (50/Tube)
LIA120STR	Tape and Reel (1000/Reel)

Absolute Maximum Ratings (@ 25° C)

Parameter	Symbol	Ratings	Units
Photodiode Cathode-Anode Voltage	V_{KAO}	20	V
Photodiode Anode-Cathode Voltage	V_{AKO}	0.5	V
Input Voltage	V_{LED}	9	V
Input DC Current	I_{LED}	20	mA
Total Power Dissipation (note 1)	P_D	145	mW
Operating Temperature	T	-40 to +85	°C
Storage Temperature	T	-40 to +125	°C

¹ Derate linearly from 25°C at a rate of 2.42 mW/°C.

Absolute Maximum Ratings are stress ratings. Stresses in excess of these ratings can cause permanent damage to the device. Functional operation of the device at conditions beyond those indicated in the operational sections of this data sheet is not implied.

Electrical Characteristics:

Parameter	Conditions	Symbol	Min	Typ	Max	Units
Input Characteristics @ 25°C						
LED forward voltage	$I_{LED} = 5 \text{ mA}, V_{COMP} = V_{FB}$ (Fig.1)	V_F	0.8	1.2	1.4	V
Reference voltage	$I_{LED} = 10 \text{ mA}, V_{COMP} = V_{FB}$ (Fig.1) $T_A = -40 \text{ to } +85^\circ\text{C}$ $T_A = 25^\circ\text{C}$	V_{REF}	1.210	-	1.265	V
			1.228	1.24	1.252	
Deviation of V_{REF} over temperature - See Note 1	$T_A = -40 \text{ to } +85^\circ\text{C}$	$V_{REF(DEV)}$	-	32	-	mV
Transfer Characteristics @ 25°C						
Current Transfer Ratio in Feedback (I_{REF}/I_{LED})	$I_{LED} = 5 \text{ mA}, V_{REF} = 0.5 \text{ V}$ (Fig.2)	K_1	1.0	2	3.0	%
Current transfer ratio (I_{KA}/I_{LED})	$I_{LED} = 5 \text{ mA}, V_{COMP} = V_{FB}, V_{KA} = 5 \text{ V}$ (Fig. 4)	K_2	1.0	2	3.0	%
Current Transfer Ratio Matching (I_{KA}/I_{REF})	$I_{LED} = 5 \text{ mA}, V_{KA} = 5.0 \text{ V}$	K_3	85	100	115	%
Feedback input current	$I_{LED} = 10 \text{ mA}, R_1 = 10 \text{ k}\Omega$ (Fig.2)	I_{REF}	-	226	-	μA
Deviation of I_{REF} over temperature - See Note 1	$T_A = -40 \text{ to } +85^\circ\text{C}$	$I_{REF(DEV)}$	-	110	-	μA
Minimum drive current	$V_{COMP} = V_{FB}$ (Fig.1)	$I_{LED(MIN)}$	1	-	-	mA
Off-state error amplifier current	$V_{IN} = 6 \text{ V}, V_{FB} = 0$ (Fig.3)	I_{OFF}	-	0.001	0.1	μA
Error amplifier output impedance - See Note 2	$I_{LED} = 0.1 \text{ mA to } 15 \text{ mA}, V_{COMP} = V_{FB}, f < 1 \text{ kHz}$ (Fig.1)	$ Z_{OUT} $	-	0.21	-	Ohm
Output Characteristics @ 25°C						
Cathode dark current	$V_{IN} = \text{Open}, V_{KA} = 10 \text{ V}$ (Fig. 3)	I_{KAO}	-	0.3	100	nA
Cathode-Anode voltage breakdown	$I_{KA} = 1 \mu\text{A}$	BV_{KA}	20	-	-	V
Isolation Characteristics @ 25°C						
Withstand insulation voltage	$RH \leq 50\%, T_A = 25^\circ\text{C}, t = 1 \text{ min}$ (Note 3)	V_{ISO}	3750	-	-	V_{rms}
Resistance (input to output)	$V_{I-O} = 500 \text{ V}_{DC}$ (Note 3)	R_{I-O}	-	10^{12}	-	Ω
AC Characteristics @ 25°C						
Bandwidth (LED) - See Note 4		B_W	-	100	-	kHz
Common mode rejection ratio - See Note 5	$I_{LED} = 1.0 \text{ mA}, R_L = 100 \text{ k}\Omega, f = 100 \text{ Hz}$ (Fig. 5)	CMRR	-	70	-	dB
Linearity	$I_{LED} = 5 \text{ mA}, 100 \text{ mV}_{PP}$	THD	-	70	-	dB

1. The deviation parameters $V_{REF(DEV)}$ and $I_{REF(DEV)}$ are defined as the differences between the maximum and minimum values obtained over the rated temperature range. The average full-range temperature coefficient of the reference input voltage, ΔV_{REF} is defined as:

$$|\Delta V_{REF}| (\text{ppm}/^\circ\text{C}) = (V_{REF(DEV)}/V_{REF}(T_A 25^\circ\text{C})) \times 10^6 / \Delta T_A$$

where ΔT_A is the rated operating free-air temperature range of the device.

2. The dynamic impedance is defined as $|Z_{OUT}| = \Delta V_{COMP}/\Delta I_{LED}$, for the application circuit in Figure 6, $|Z_{OUT}| \approx K_1 R_1$

3. Device is considered as a two terminal device: Pins 1, 2, 3 and 4 are shorted together and Pins 5, 6, 7 and 8 are shorted together.

4. See compensation section for calculating bandwidth of LIA120.

5. Common mode transient immunity at output high is the maximum tolerable (positive) dV_{cm}/dt on the leading edge of the common mode impulse signal, V_{cm} , to assure that the output will remain high. Common mode transient immunity at output low is the maximum tolerable (negative) dV_{cm}/dt on the trailing edge of the common pulse signal, V_{cm} , to assure that the output will remain low.

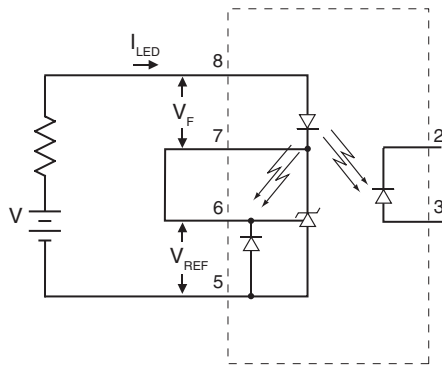

FIG. 1. V_{REF} , V_F , $I_{LED (MIN)}$ TEST CIRCUIT

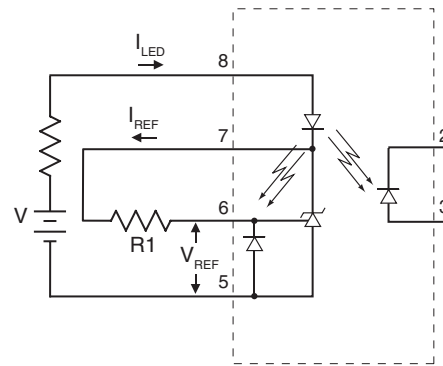

FIG. 2. I_{REF} TEST CIRCUIT

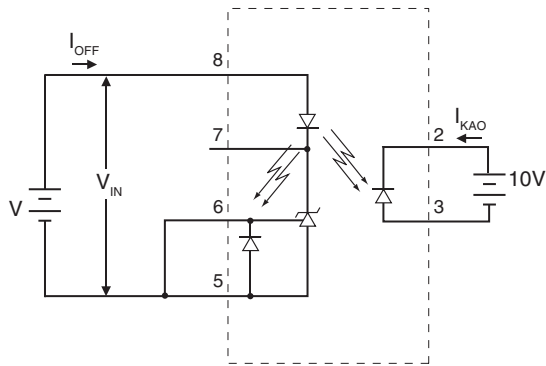

FIG. 3. I_{OFF} , I_{KAO} TEST CIRCUIT

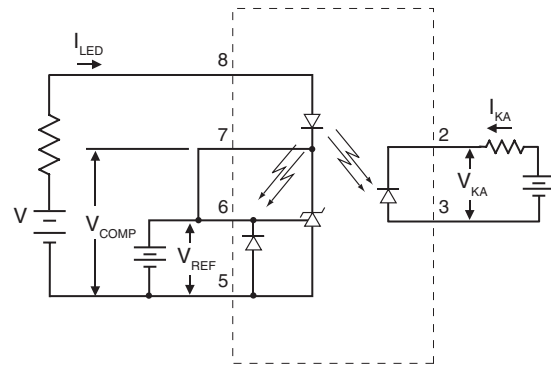

FIG. 4. CTR TEST CIRCUIT

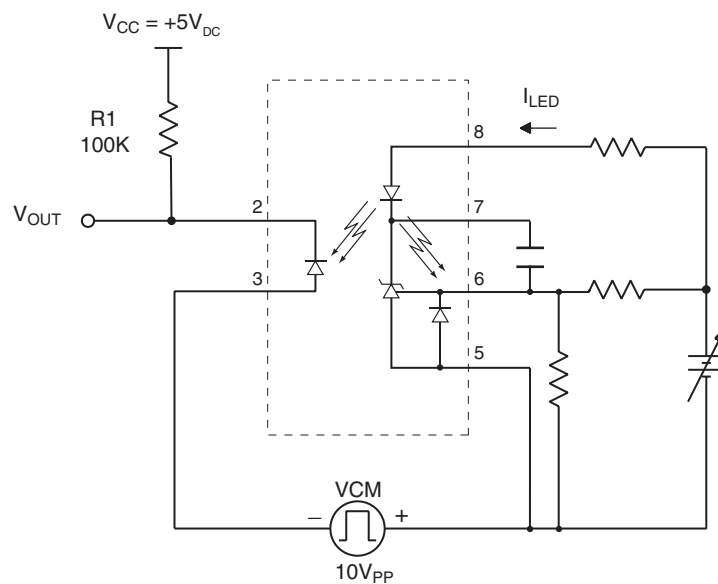
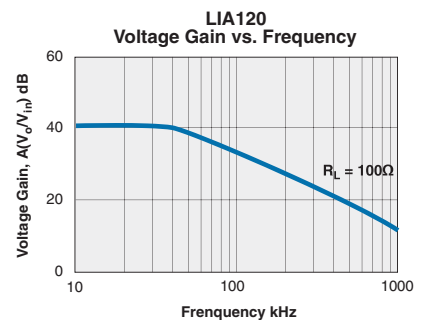
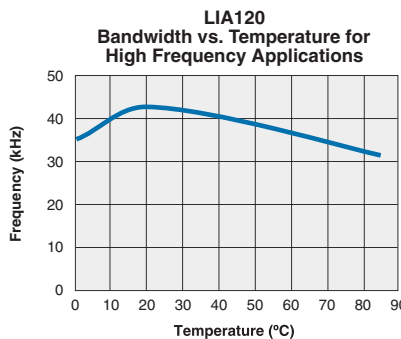
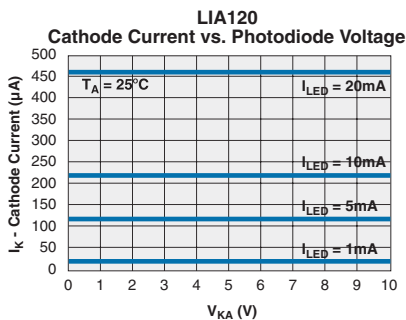
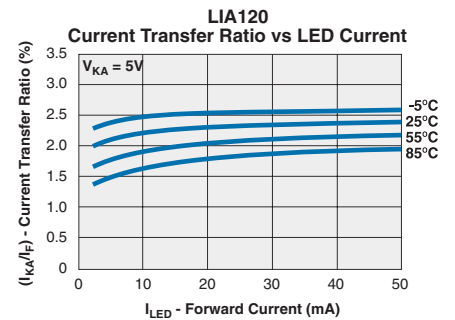
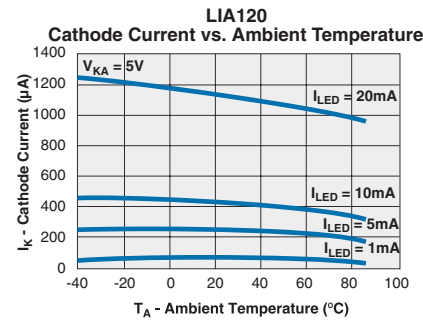
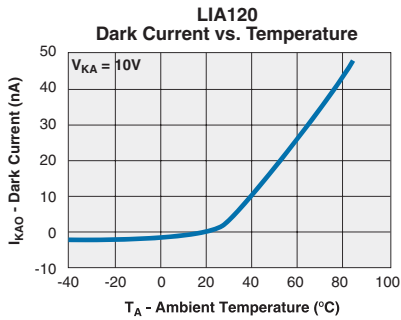
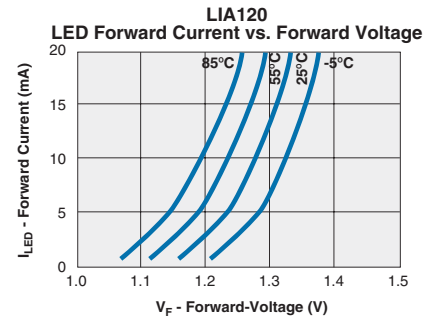
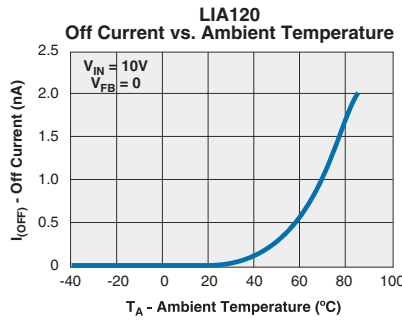
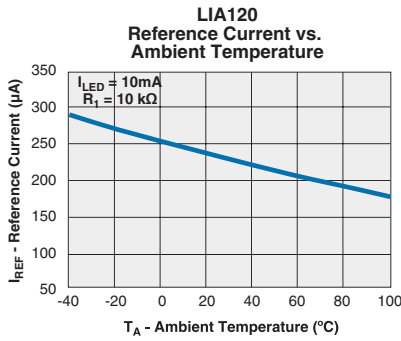
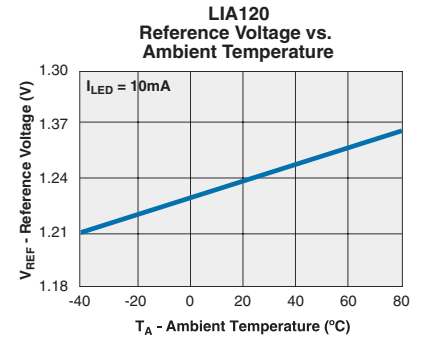
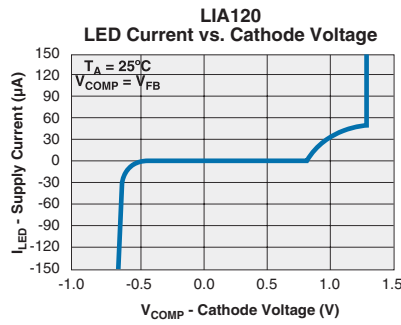
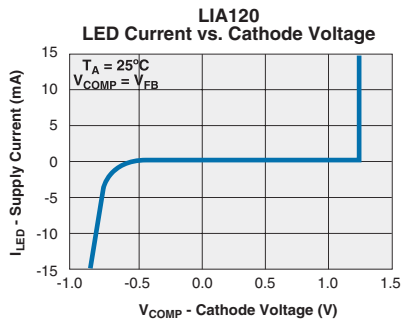

Fig. 5. CMRR Test Circuit

PERFORMANCE DATA*



*The Performance data shown in the graphs above is typical of device performance. For guaranteed parameters not indicated in the written specifications, please contact our application department.

PERFORMANCE DATA*

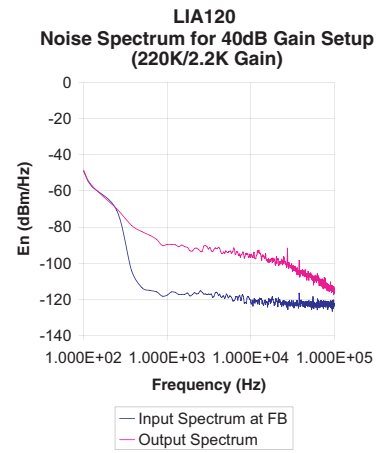
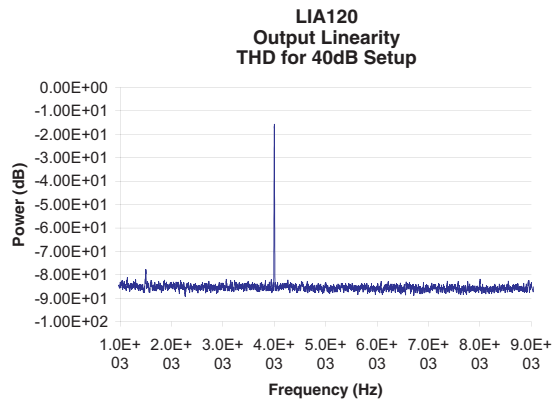

*The Performance data shown in the graphs above is typical of device performance. For guaranteed parameters not indicated in the written specifications, please contact our application department.

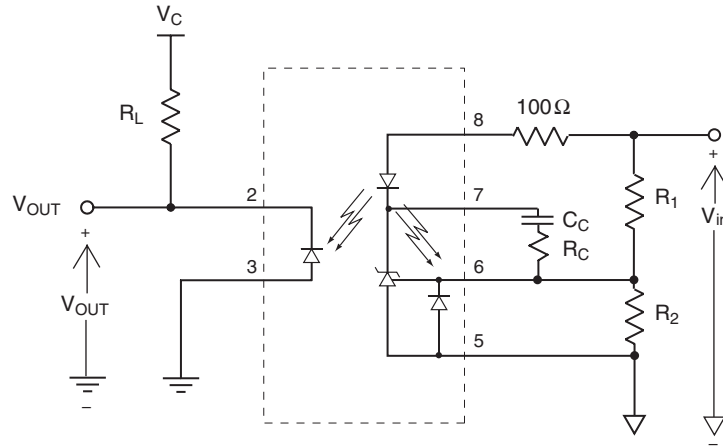

Fig. 6. Power Supply Feedback Application Circuit

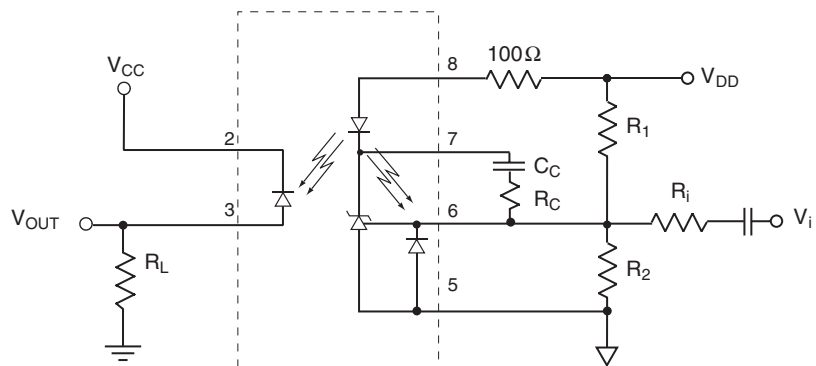

Fig. 7. Non-inverting Linear Amplifier Circuit

The LIA120

The LIA120 is an optically-coupled isolated linear error amplifier. It integrates three of the most fundamental elements necessary to make an isolated power supply: a reference voltage, an error amplifier, and an isolated coupling devices. It is functionally equivalent to a 431 type shunt regulator plus a linear optical amplifier.

Powering the Isolated Input

The isolated input of the LIA120 is powered through the LED pin (pin 8) via the part to it's isolated ground at pin 5. The typical operating current of the device is determined by the output voltage and current requirements as well as the CTR of the linear optocoupler. For Figure 7, the LED current requirement is set by the following equation.

$$I_{LED} = \frac{V_{out, bias}}{R_L \cdot K_1}$$

The output voltage is typically constrained by the user to satisfy the design requirements of the application circuit. Design considerations must also take into account that R_L affects the total gain and that CTR gains vary with process. Nominally the LED current should be around 1-2mA but can be as high as 10-15mA if the user requires.

LED current is limited by the resistor in series with pin 8, the LED pin, to the supply and is typically 10-100 ohms for operating currents of 1-2mA. The minimum operating voltage of 2.74V for the LIA120 from pin 8 to pin 5 is based on the sum of the voltage drop of the LED and the operational voltage headroom of the 431. Minimum operating voltage for the application circuit is therefore the sum of the LIA120 minimum operating voltage plus the voltage drop of the current limiting resistor. For a design with 1mA of LED current and a current limiting resistor of 100 ohms, the minimum operating voltage is calculated to be $2.74 + (0.001)(100) = 2.84V$.

Feedback

Setting the gain for the LIA120 is accomplished simply by setting two resistors. The application circuit in Figure 6 shows a resistor divider feeding the FB pin, so the operating conditions for the gain are governed by:

$$\frac{R_1}{R_2} = \frac{V_{in}}{V_{ref}} - \left(\frac{V_{out}}{V_{ref}} \cdot \frac{R_1}{R_L} \right) \cdot \frac{1}{K_3} - 1$$

K_3 is taken from the datasheet as 1 nominally. The ac gain of the setup can be represented by:

$$A_V(V_{OUT}/V_{IN}) = \frac{R_L}{R_1} \cdot \left(\frac{R_2 \parallel R_1 \parallel \left(\frac{1}{G_m \cdot CTR_{FB}} \right)}{\left(\frac{1}{G_m \cdot CTR_{Forward}} \right)} \right)$$

Where:

- $G_m = 1/Z_{OUT}$ which is ~ 3 Siemens
- CTR_{FB} is approximately $CTR_{Forward} = 0.02$ nominally
 $CTR_{FB} = K_1$, $CTR_{FORWARD} = K_2$, $CTR_{FORWARD}/CTR_{FB} = K_3$

This calculation provides a more accurate gain calculation but is only necessary when the voltage divider resistor's impedance is becoming close to the optical output impedance of the shunt regulator.

Compensation

The LIA120 is relatively easy to compensate but two factors must be considered when analyzing the circuit. The frequency response of the LIA120 can be as high as 40kHz, but must be limited because of the closed loop optical feedback to the input signal. In the localized optical feedback there are two poles to consider, the 431 dominant pole and the linear optical coupler pole. The open loop gain of the optical loop (for the application diagram) is:

$$A_{V, OPTICAL} = G_m \cdot CTR_{FB} \cdot R_1 \parallel R_2$$

The open loop gain is affected by the selection of R_1 and R_2 and without any compensation the circuit may oscillate. The addition of a compensation network (C_c and R_c) control the maximum bandwidth so that open loop gain is rolling off long before the optical pole causes the circuit to oscillate. The optical pole is at ~180kHz so the bandwidth is typically limited to less than 40kHz.

While there is flexibility in the part to change the compensation technique, the upper limit on frequency response is generally desired to be such that the circuit will not oscillate for a large selection of R_1 and R_2 . Therefore the compensation capacitor should not be less than 100pF which gives adequate bandwidth for most designs. The bandwidth through the part will be:

$$BW(Hz) = \frac{G_m \cdot CTR_{FB} \cdot R_1 \parallel R_2}{2 \cdot \pi \cdot \left(G_m \cdot R_{LED} \cdot C_c \cdot R_1 \parallel R_2 + \frac{1}{P_1} \right)} \leq BW(Hz)_{MAX}$$

Where:

P_1 max is 1kHz (6.28krad/s) due to the internal compensation of the 431.

CTR is the current transfer ratio of the feedback optocoupler (0.001-0.003).

R_{LED} is the combined impedance of the limiting resistor and the LED resistance (25 ohms) and G_m is the transconductance of the 431 (3 Siemens).

However, since some of these elements vary over operating conditions and temperature, the bandwidth should be practically limited to less than 40kHz to avoid oscillations, which is the value computed by 100pF.

Photodiode

The output of the LIA120 is a photodiode capable of withstanding high voltages. For the most accurate results, attempt to bias the voltage across the cathode anode the same as V_{REF} . The load resistors can be placed in series with the cathode or anode for desired output polarity.

Manufacturing Information

Soldering

Recommended soldering processes are limited to 245°C component body temperature for 10 seconds.

Washing

Clare does not recommend ultrasonic cleaning or the use of chlorinated solvents.

MECHANICAL DIMENSIONS

8 Pin Surface Mount (“S” Suffix)

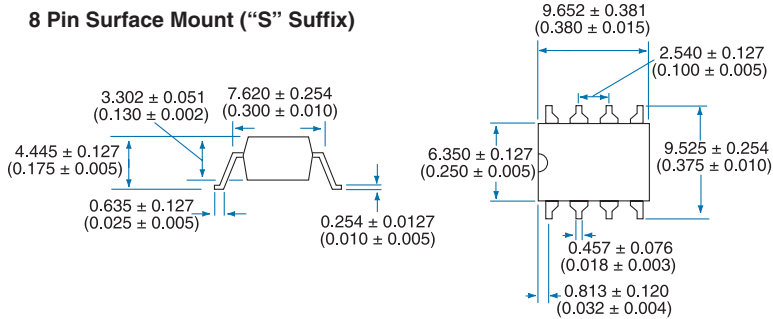

PC Board Pattern (Top View)

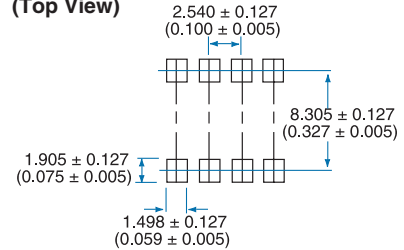

Tape and Reel Packaging for 8 Pin Surface Mount Package

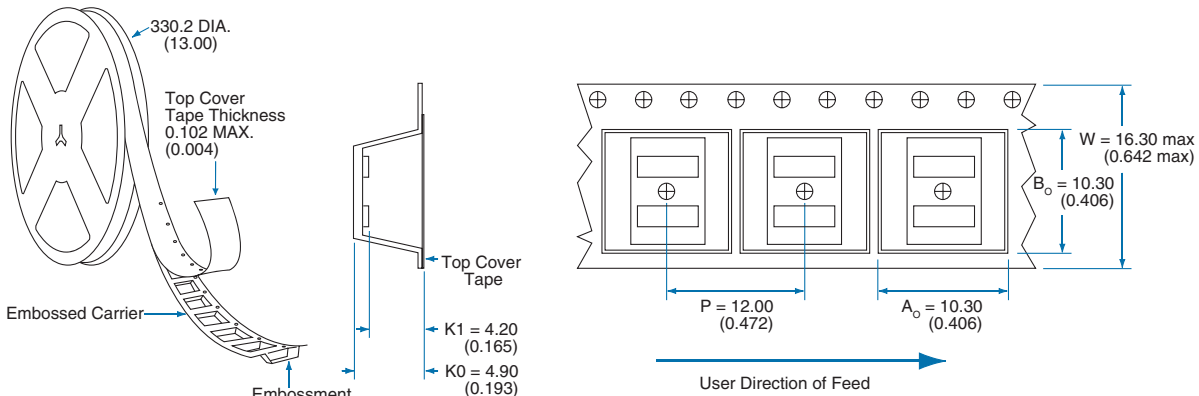

NOTE: Tape dimensions not shown, comply with JEDEC Standard EIA-481-2

Dimensions:
mm
(inches)

For additional information please visit our website at: www.clare.com

Clare, Inc. makes no representations or warranties with respect to the accuracy or completeness of the contents of this publication and reserves the right to make changes to specifications and product descriptions at any time without notice. Neither circuit patent licenses nor indemnity are expressed or implied. Except as set forth in Clare's Standard Terms and Conditions of Sale, Clare, Inc. assumes no liability whatsoever, and disclaims any express or implied warranty, relating to its products including, but not limited to, the implied warranty of merchantability, fitness for a particular purpose, or infringement of any intellectual property right.

The products described in this document are not designed, intended, authorized or warranted for use as components in systems intended for surgical implant into the body, or in other applications intended to support or sustain life, or where malfunction of Clare's product may result in direct physical harm, injury, or death to a person or severe property or environmental damage. Clare, Inc. reserves the right to discontinue or make changes to its products at any time without notice.