



Z86229

NTSC LINE 21 CCD DECODER

FEATURES

Devices	Speed (MHz)	Pin Count/ Package Types	Standard Temp. Range	Automatic Data Extraction		
				On-Screen Display & Closed Captioning	Program Rating	Time of Day
Z86229	12	18-Pin DIP, SOIC	0°C to +70°C	Yes	Yes	Yes

- Complete Stand-Alone Line 21 Decoder for Closed-Captioned and Extended Data Services (XDS)
- Preprogrammed to Provide Full Compliance with EIA-608 Specifications for Extended Data Services
- Automatic Extraction and Serial Output of Special XDS Packets (Time of Day, Local Time Zone, and Program Blocking)
- Programmable XDS Filter for a Specific XDS Packet
- Cost-Effective Solution for NTSC Violence Blocking inside Picture-in-Picture (PiP) Windows
- Minimal Communications and Control Overhead Provide Simple Implementation of Violence Blocking, Closed Captioning, and Auto Clock Set Features
- Programmable, On-Screen Display (OSD) for Creating Full Screen OSD or Captions inside a Picture-in-Picture (PiP) Window
- User-Programmable Horizontal Display Position for easy OSD Centering and Adjustment
- I²C Serial Data and Control Communication
- Supports 2 Selectable I²C Addresses

GENERAL DESCRIPTION

Capable of processing Vertical Blanking Interval (VBI) data from both fields of the video frame in data, the Z86229 Line 21 Decoder offers a feature-rich solution for any television or set-top application. The robust nature of the Z86229 helps the device conform to the transmission format defined in the Television Decoder Circuits Act of 1990, and in accordance with the Electronics Industry Association specification 608 (EIA-608).

The Line 21 data stream can consist of data from several data channels multiplexed together. Field 1 consists of four data channels: two Captions and two Texts. Field 2 consists of five additional data channels: two Captions, two Texts, and Extended Data Services (XDS). The XDS data structure is

defined in EIA-608. The Z86229 can recover and display data transmitted on any of these nine data channels.

The Z86229 can recover and output to a host processor via the I²C serial bus. The recovered XDS data packet is further defined in the EIA-608 specification. The on-chip XDS filters in the Z86229 are fully programmable, enabling recovery of only those XDS data packets selected by the user. This functionality allows the device to extract the required XDS information with proper XDS filter setup for compatibility in a variety of TVs, VCRs, and Set-Top boxes.

In addition, the Z86229 is ideally suited to monitor Line 21 video displayed in a PiP window for violence blocking, CCD, and other XDS data services. A block diagram of the Z86229 is illustrated in Figure 1.

GENERAL DESCRIPTION (Continued)

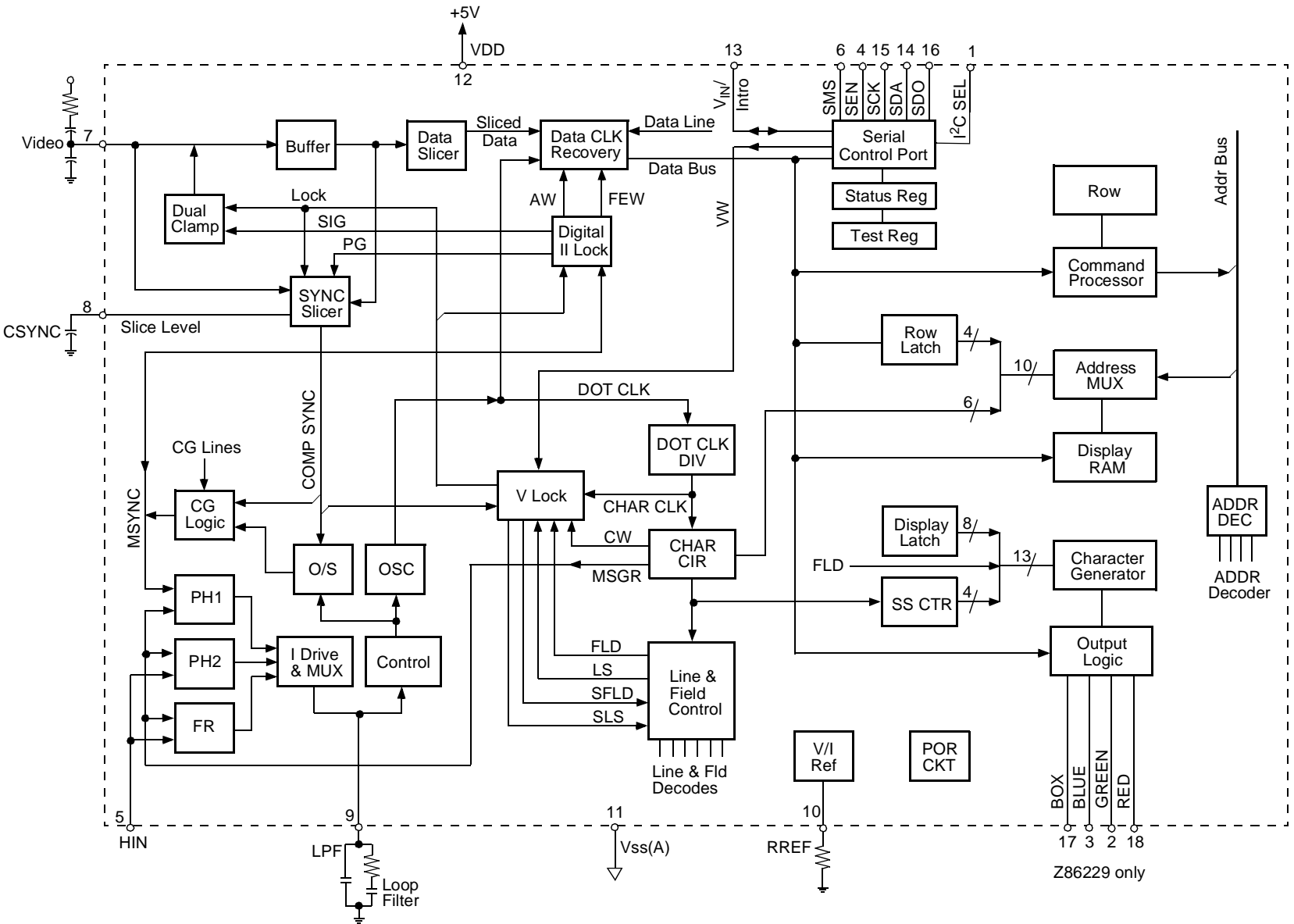

Figure 1. Z86229 Block Diagram

PIN DESCRIPTION

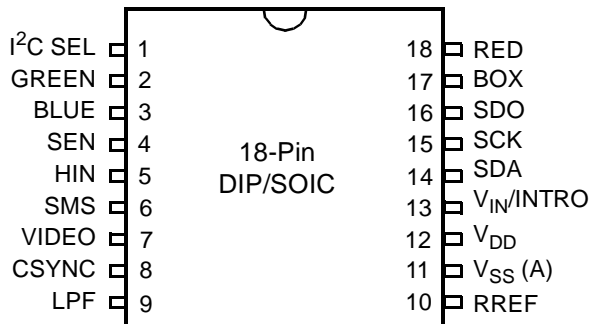

Figure 2. Z86229 Pin Configuration

Table 1. Z86229 Pin Identification*

No.	Symbol	Function	Direction
1	I ² C SEL	I ² C Address Selection	Input
2	GREEN	Video Output	Output
3	BLUE	Video Output	Output
4	SEN	Serial Enable	Input
5	HIN	Horizontal In	Input
6	SMS	Serial Mode Select	Input
7	VIDEO	Composite Video	Input
8	CSYNC	Composite Sync	Output
9	LPF	Loop Filter	Output
10	RREF	Resistor Reference	Input
11	V _{SS} (A)	Pwr. Supply (Analog) GND	
12	V _{DD}	Power Supply	
13	V _{IN} /INTRO	Vertical In/Interrupt Out	In/Output
14	SDA	Serial Data	In/Output
15	SCK	Serial Clock	Input
16	SDO	Serial Data Out	Output
17	BOX	OSD Timing Signal	Output
18	RED	Video Output	Output

Note: *DIP and SOIC pin configurations are identical.

ABSOLUTE MAXIMUM RATINGS*

Symbol	Parameter	Value	Unit
V _{DD}	DC Supply Voltage	-0.5 to 6.0	V
V _{IN}	DC Input Voltage	-0.5 to V _{DD} + 0.5	V
V _{OUT}	DC Output Voltage	-0.5 to V _{DD} + 0.5	V
I _{IN}	DC Input Current per Pin	+ 10	mA
I _{OUT}	DC Output Current per Pin	+ 20	mA
I _{DD}	DC Supply Current	+ 30	mA
P _D	Power Dissipation per Device	300	mW
T _{STG}	Storage Temperature	-65 to +150	°C
T _L	Lead Temperature, 1 mm from Case for 10 seconds	260	°C

Notes:

*Voltages referenced to V_{SS} (A). Values beyond the maximum ratings listed above may cause damage to the device. Functional operation should be restricted to the limits specified in the DC and AC Characteristics tables or Pin Description section.

STANDARD TEST CONDITIONS

The characteristics listed below apply for standard test conditions as noted. All voltages are referenced to Ground. Positive current flows into the referenced pin (Figure 3).

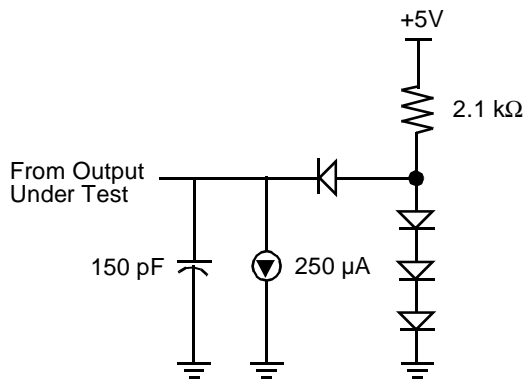

Figure 3. Standard Test Load

DC ELECTRICAL CHARACTERISTICS

Symbol	Parameter	Conditions	Minimum	Maximum	Unit
V_{IL}	Input Voltage Low		0	$0.2 V_{DD}$	V
V_{IH}	Input Voltage High		$0.7 V_{DD}$	V_{DD}	V
V_{OL}	Output Voltage Low	$I_{OL} = 1.00 \text{ mA}$	-	0.4	V
V_{OH}	Output Voltage High	$I_{OH} = 0.75 \text{ mA}$	$V_{DD} - 0.4V$	-	V
I_{IL}	Input Leakage	$0V, V_{DD}$	-3.0	3.0	μA
I_{DD}	Supply Current			30	mA

Notes: $T_A = 0^\circ\text{C}$ to $+70^\circ\text{C}$; $V_{DD} = +4.75V$ to $+5.25V$.

AC AND TIMING CHARACTERISTICS

Table 2. Composite Video Input

Parameter	Conditions
Amplitude	1.0V p-p $\pm 3 \text{ dB}$
Polarity	Sync tips negative
Bandwidth	600 kHz
Signal Type	Interlaced
Max Input R	470 ohms
DC Offset	Signal to be AC coupled with a minimum series capacitance of $0.1 \mu\text{F}$.

ELECTRICAL CHARACTERISTICS

Nonstandard Video Signals must have the characteristics indicated in Tables 3–6.

Table 3. Non-Standard Video Signal Characteristics

Parameter	Conditions
Sync Amplitude	200 mV minimum
Vertical Pulse Width	3H \pm 0.5H
Vertical Pulse Tilt	20 mV maximum
H Timing	Phase Step (Head Switch) \pm 10 μ s maximum Fh Deviation (long term) \pm 0.5% maximum Fh p-p Deviation (short term) \pm 0.3% maximum
Vertical Sync Signal	The internal sync circuits locks to all 525 or 625 line signals having a vertical sync pulse that meets the following conditions: <ul style="list-style-type: none"> • It is at least 3H \pm 0.5H wide. • It starts at the proper 2H boundary for its field. • If equalizing pulse serrations are present, they must be less than 0.125H in width.
Minimum Signal-to-Noise	The Z86229 functions down to a 25 dB signal-to-noise ratio (CCIR-weighted) with one error per row or better at that level.
Ratio to Composite Video	Input

Table 4. Horizontal Signal Input

Parameter	Conditions
Amplitude	CMOS level signal where Low \leq 0.2 V _{CC}
Video-Lock Mode	Polarity Any Frequency 15,734.263 Hz \pm 3%
HIN Lock Mode	Polarity Any Frequency Same as Display Horizontal Flyback Pulse (HFB) pulse

Table 5. Line Input Parameters

Parameter	Conditions
Code Amplitude	50 IRE
Code Zero Level	5 IRE, + 15 IRE relative to Back Porch
Start of Code	10.5 \pm 0.5 μ s (Measure from the midpoint of the leading edge of the composite video Hsync pulse to the midpoint of the rising edge of the first clock run-in cycle.)
Start of the Data	3.972 μ s, -0.00 μ s, + 0.30 μ s (Measure from the midpoint of the falling edge of the most recent clock run-in cycle to the midpoint of the rising edge of the start bit.)

Note: Line 21 must be in its proper position to the leading edge of the Vertical Sync signal.

ELECTRICAL CHARACTERISTICS (Continued)

Table 6. Timing Signals

Parameter	Conditions
Dot	$768 \times FH = 12.0839 \text{ MHz}$
Dot Period	82.75 ns
Character Cell Width	$1.324 \mu\text{s} (tH/48)$
Width of Row (Box)	$45.018 \mu\text{s} (34 \text{ chars} = 17/24 \times tH)$
Width of Row (Char)	$42.370 \mu\text{s} (32 \text{ chars} = 2/3 \times tH)$
Horizontal Display Timing	The timing of the output signals Box and RGB have been set to make a centered display. The positioning of these outputs can be adjusted in 330 ns increments by writing a new value to the Z86229 H Position Register (Address = 02h).

PIN DEFINITIONS

Inputs

I²C SEL (Pin 1). This pin selects 28h for writing and 29h for reading when this input is Low(0). When the input is High(1), the device selects 2Ah for writing and 2Bh for reading.

SEN (Pin 4). This pin enables the signal for the SPI mode of operation on the Serial Control Port. When this pin is Low (0), the SPI port is disabled and the SDO pin is in the high-impedance state. Transitions on the SCK and SDA pins are ignored. SPI mode operation is enabled when SMS is High (1).

HIN (Pin 5). For this pin, the Horizontal Sync input signal at the CMOS level must be supplied. When the device is used in VIDEO-LOCK mode, the signal pulls the on-chip VCO within the proper range. The circuit uses the frequency of this signal, which must be within $\pm 3\% F_H$, but the overall signal can be of either polarity. When used in the H-lock mode, the VCO phase locks to the rising edge of this signal. The HPOL bit of the H Position register can be set to operate with either polarity of input signal. This signal is usually the H Flyback signal. The timing difference between HIN rising edge and the leading edge of composite sync (of VIDEO input) is one of the factors which affects the horizontal position of the display. Any shift resulting from the timing of this signal can be compensated for with the horizontal timing value in the H Position Register. H-lock is intended for use when the part is generating an OSD display when no video signal is present.

SMS (Pin 6). This pin allows the mode select pin for the Serial Control Port. When this input is at a CMOS High state (1), the Serial Control Port operates in the SPI mode. When the input is Low (0), the Serial Control Port operates in the I²C slave mode. In SPI mode, the SEN pin must be tied High. (See Reset Operation section.)

VIDEO (Pin 7). This pin is a composite NTSC video input, 1.0V p-p (nom), band limited to 600 kHz. The circuit operates with signal variation between 0.7–1.4V p-p. The polarity is sync tips negative. This signal pin should be AC coupled through a 0.1 μ F capacitor, driven by a source impedance of 470 ohms or less.

SCK (Pin 15). This pin is an input for a serial clock signal from the master control device. In I²C mode operation, the clock rate is expected to be within I²C limits. In SPI mode, the maximum clock frequency is 10 MHz.

Reset Operation. When the SMS and SEN pins are both in the Low (0) state, the part is in the Reset state; therefore, in the I²C mode, the SEN pin can be used as an NReset input. When SPI mode is used, if three wire operation is required, both SMS and SEN can be tied together and used as the NReset input. In either mode, NReset must be held Low (0) for at least 100 ns.

Input/Output

V_{IN}/INTRO (Pin 13). In external (EXT) vertical lock mode of operation, the internal vertical sync circuits lock to the V_{IN} input signal applied at this pin. The part locks to the rising or falling edge of the signal in accordance with the setting of the V Polarity command. The default is rising edge. The V_{IN} pulse must be at least 2 lines wide.

In INTRO Mode, when configured for internal vertical synchronization, this pin is an output pin providing an interrupt signal to the master control device in accordance with the settings in the Interrupt Mask Register.

SDA (Pin 14). When the Serial Control Port has been set to I²C mode operation, this pin serves as the bidirectional data line for sending and receiving serial data. In SPI mode operation, the device operates as a serial data input. SPI mode output data is available on the SDO pin.

Outputs

RED, GREEN, BLUE (Pins 2, 3, 18). These pins are ositive-acting CMOS-level signals.

- **Color Mode:** Red, Green, and Blue characters are incorporated as video outputs for use in a color receiver
- **Mono Mode:** In this mode, all three outputs carry the character luminance information

Note: The selection of Color/Mono Mode is user controlled in bit D₁ of the Configuration Register (Address=00h). (See Internal Registers section.)

CSync (Pin 8). Sync slice level. A 0.1 μ F capacitor must be tied between this pin and analog ground V_{SS(A)}. This capacitor stores the sync slice level voltage.

LPF (Pin 9). Loop Filter. A series RC low-pass filter must be tied between this pin and analog ground V_{SS(A)}. There must also be second capacitor from the pin to V_{SS(A)}.

PIN DEFINITIONS (Continued)

RREF (Pin 10). Reference setting resistor. Resistor must be 10 kOhms, $\pm 2\%$.

SDO (Pin 16). This pin provides the serial data output when SPI mode communications have been selected. This pin is not used in I²C mode operation.

BOX (Pin 17). Black box keying output is an active High, CMOS-level signal used to key in the black box for captions/text displays. This output is in a high-impedance state when the background attribute has been set to semi-transparent.

Power Supply

V_{SS} (Pins 11). These pins are the lowest potential power pins for the analog and digital circuits. They are normally tied to system ground.

V_{DD} (Pin 12). The voltage on this pin is nominally 5.0 Volts, and may range between 4.75 to 5.25 Volts with respect to the V_{SS} pins.

Note: The recommended printed circuit pattern for implementing the power connection and critical components is referenced in the Recommended Application Information section on page 49.

Z86229 BLOCK DIAGRAM DESCRIPTION

The Z86229 is designed to process both fields of Line 21 on a television VBI and provide the functional performance of a Line 21 Closed-Caption decoder and Extended Data Service decoder. This device requires two input signals, Composite Video and a horizontal timing signal (HIN), and several passive components for proper operation. A vertical input signal is also required if OSD display mode is required when no video signal is present. The Decoder performs several functions, including extraction of data from Line 21, separation of the normal Line 21 data from the XDS data, on-screen display of the selected data channel, and outputting of the XDS data through the serial communications channel.

Input Signals

The Composite Video input signal is rated at a nominal 1.0 Volt p-p, with sync tips negative and band-limited to 600 kHz. The Z86229 operates with an input level variation of ± 3 dB.

The HIN input signal is necessary to bring the VCO close to the required operating frequency. This signal must be a CMOS-level signal. The HIN signal can have positive or negative polarity, and the signal is only required to be within 3% of the standard H frequency. When configured for EXT HLK operation, this signal should correspond to the H Fly-back signal.

The timing difference between the HIN rising edge and the leading edge of composite sync (of VIDEO input) is one of the factors that affects the horizontal position of the display. Any shift resulting from the timing of this signal can be compensated for with the horizontal timing value in the H Position register.

Video Input Signal Processing

The Composite Video input is AC-coupled to the device. The sync tip is internally clamped to a fixed reference voltage by means of a dual clamp. Initially, the unlocked signal is clamped using a simple clamp. Improved impulse noise performance is then achieved after the internal sync circuits lock to the incoming signal. Noise rejection is obtained by making the clamp operative only during the sync tip. The clamped composite video signal is fed to both the Data Slicer and Sync Slicer blocks.

The Data Slicer generates a clean CMOS-level data signal by slicing the signal at its midpoint. The slice level is established on an adaptive basis during Line 21. The resulting value is stored until the next occurrence of Line 21. A high level of noise immunity is achieved by using this process.

The Sync Slicer processes the clamped Comp Video signal to extract Comp Sync. This signal is used to lock the internally generated sync to the incoming video when the video-lock mode of operation has been enabled. Sync slicing is performed in two steps. In the non-locked mode, the sync is sliced at a fixed offset level from the sync tip. When proper lock operation has been achieved, the slice level voltage switches from a fixed reference level to an adaptive level. The slice level is stored on the sync slice capacitor (CSYNC).

The Data Clock Recovery circuit operates in conjunction with the Digital H-lock circuit. The circuit produces a 32H clock signal (DCLK) that is locked in phase to the clock run-in burst portion of the sliced data obtained from the Data Slicer. When the Line 21 code appears, the DCLK phase lock is achieved during the clock run-in burst and is used to reclock the sliced data. After phase lock is established it is maintained until a change in the video signal occurs.

The Digital H-Lock circuit produces a variety of signals, including the video timing gates, PG and STG. These signals are all locked in-phase with the HSYNC and the video timing signal, no matter which H-lock mode is used in the display generation circuits. This independent phase lock loop is able to respond quickly to changes in video timing without concern for display stability requirements.

VCO and One Shot

All internal timing and synchronizing signals are derived from the on-board 12-MHz VCO. The VCO output is the DOT CLK signal used to drive both the Horizontal and Vertical counter chains and display timing. The One Shot circuit produces a horizontal timing signal which is derived from the incoming video, and qualified by a Copy Guard logic circuit.

The VCO can be locked in phase to two different sources. For television operation, where a good horizontal display timing signal is available, the VCO is locked to the HIN input through the action of the Phase Detector (PH2). When a proper HIN signal is not available (such as in a VCR), the VCO can be locked to the incoming video through the Phase Detector (PH1). In this case, the frequency detector (FR) circuit is activated (as required) to bring the VCO within the pull-in range of PH1.

Timing and Counting Circuits

The DOT CLK is first divided down to produce the character timing clock CHAR CLK. This signal is then further divided to generate the horizontal timing signals H, 2H and

Z86229 BLOCK DIAGRAM DESCRIPTION (Continued)

HSQR. These timing signals are used in the data output (display) circuits.

The H signal is further divided in the LINE and FLD CNTR to produce the various decodes used to establish vertical lock, time displays, and control functions required for proper operation. The H signal is also used to generate the Smooth Scroll timing signal for display.

The V Lock circuits produce a noise free vertical pulse derived from the horizontal timing signal. When the user selects Video as the vertical lock source, the internal synchronizing signals are phased up with the incoming video by comparing the internally generated vertical pulse to an input vertical pulse. These pulses are derived from the Comp Sync signal provided by the Sync Slicer. In the vertical lock set to V_{IN} mode, the V_{IN} signal is used in place of the signal derived from Comp Sync. In either case, when proper phasing has been established, this circuit outputs the LOCK signal which is used to provide additional noise immunity to the slicing circuits.

The LOCKed state is established only after several successive fields have occurred and the two vertical pulses remain in sync. When LOCKed, the internal timing will flywheel until the timing of the two vertical pulses lose coincidence for a number of consecutive fields. Until LOCK is established, the decoder operates on a pulse-by-pulse basis.

Command Processor

The Command Processor circuit controls the manipulation of the data for storage and display. This circuit processes the Control Port input commands to determine the display status required and the data channel selected. During the display time (lines 43–237), this information is used to control the loading, addressing, clearing of the Display RAM, and the operations of the Character ROM and Output Logic circuits.

During data recovery time (TV lines 21–42), the Command Processor, in conjunction with the data recovery circuits, recovers the XDS data and the data for the selected data channel. Data is sent to the RAM for storage and display and/or to the serial port, as appropriate. Where necessary, the Command Processor converts the input data to the appropriate form.

Output Logic

The Output Logic circuits operate together to generate the output color signals RED, GREEN and BLUE, and the Box signal. When MONOchrome mode is selected, all three color outputs carry the luminance information. These outputs are positive output logic signals.

The character ROM contains the dot pattern for all the characters. The output logic provides the hardware underline, graphics characters, and the Italics slant-generator circuits. The smooth scroll display is achieved by the smooth scroll counter logic, which controls the addressing of the Character ROM.

Decoder Control Circuit

The Decoder Control Circuit block is the users communications port. The circuit converts the information provided to the control port into the necessary internal control signals required to establish the operating mode of the decoder. This port can be operated in one of two serial modes. The SMS pin is used to establish either of the two serial control modes.

In the two wire (I^2C) control mode, the Z86229 responds to its slave address for both the read and write conditions. If the read bit is Low (indicating a WRITE sequence), then the Z86229 responds with an acknowledge. The master should then send an address byte followed by a data byte. If the read bit is High (indicating a READ sequence), then the Z86229 responds with an acknowledge followed by a status byte and a data byte, respectively. Read data, however, is only available through indirect addressing; write addressing exhibits both indirect and direct modes. The busy bit in the status byte indicates whether the write operation has been completed or if read data is available.

The SPI mode is a three wire bus with the Z86229 acting as the slave device. Communication is synchronized by the SCK signal generated by the master. Typically, the serial data output is transmitted on the falling edge of SCK and the received data is captured on the rising edge of SCK. All data is exchanged as 8-bit bytes.

Voltage/Current Reference

The Voltage/Current Reference circuit uses an externally-connected resistor to establish the reference levels that are used throughout the Z86229. For a minimal cost, an external resistor can provide improved internal precision.

Z86229 FUNCTIONAL DESCRIPTION

The Z86229 provides full function NTSC, Line 21 performance. Input commands are included to enable the decoder to process and display any of the eight Caption/Text data channels (CC1, CC2, CC3, CC4, T1, T2, T3 or T4) contained in Line 21 of either field of the incoming video. XDS data can also be selected for the display. The DECODER ON/OFF commands control whether or not the Line 21 data in the selected channel is actually displayed. When switched to the DECODER OFF (TV) state, incoming data in the selected channel is still processed, but not displayed.

The Z86229 can also be configured to operate with PAL or SECAM video signals. The device decodes information encoded into its VBI in Line 22. The encoded data must conform to the waveform and command structure defined for NTSC Line 21 operation.

VCO Lock

The Z86229 includes a VCO with stable gain characteristics and good power supply rejection. The internal horizontal and vertical synchronizing circuits provide a high degree of noise immunity. There are options for both horizontal and vertical lock. The VCO can be phase locked either to the horizontal signal derived from the video input signal (VIDEO) or to the externally supplied HIN signal, typically horizontal flyback.

A HIN lock is used to provide a display having a minimum amount of observable jitter. The low jitter requires a HIN signal derived from a TV display that exhibits proper polarity. This type of signal is readily available in a television receiver. Video-Lock mode enables the VCO to lock in-phase to the incoming video signal, thus providing good operation in an application where no display-related HIN signal is available (such as in a VCR).

Video Timing

Timing signals are derived from the VCO for use in the line counting and display circuits. Line counting requires proper identification of the input signal's vertical pulse. Default operation uses the vertical sync signal derived from the video input signal as the source for vertical lock. This method results in locking characteristics having good performance and good noise immunity.

In the event that OSD operation is required under conditions when no input video is present, it would be necessary to set the Z86229 for V_{IN} lock. In this mode, the vertical timing is determined from the vertical pulse signal supplied to the V_{IN} pin.

The horizontal position of the caption display is determined by the internal timing circuits. A default condition has been

established that should result in a well centered display in a typical application; however, signal delays through video-processing circuits can vary between designs. The Z86229 provides the user with the ability to change the default timing. No matter which of the horizontal lock modes are selected, the display horizontal position on the screen can be adjusted in quarter character (330 ns) steps by serial port commands.

Displayable Character Set

Normal Mode. Characters are displayed as white or colored dot matrix characters on an opaque background. The Box is normally black, but the Z86229 can be set to a blue background Box with a serial command. The characters are described by a 12 by 18 dot pattern within a character cell which is 16 dots wide by 26 dots high per frame. The location of the character luminance within the character cell varies from character to character to allow for the display of lower case letters with descenders. All characters have at least a 1-dot border of black around each character. Underline is also provided. Figure 4 illustrates the Z86229 standard character map and font.

The character ROM consists of a 12 by 18 dot matrix pattern per character. Alternate rows and columns are read out in each field to produce an interleaved and rounded character. A display row contains a maximum of 32 characters plus a leading and trailing black box, each a character cell in width, making the overall width of a display row $34 \times 8 = 272$ dots. Successive display rows are butted together so that the total display occupies 195 dots high.

The black box is 34 character cells wide by 195 dots high, resulting in a box size of $45.018 \mu\text{s}$ in width by 195 scan lines in height. The Box starts in scan line 43 and extends to scan line 237. Theoretically, the display is horizontally centered in the video display when the Box starts $13.2 \mu\text{s}$ after the leading edge of H.

The default setting of the Z86229 places the center of the Box at about $13.5 \mu\text{s}$ to allow for some delay in the normal video path. However, the Box horizontal position can be adjusted by the user in 330 ns increments. The display is approximately within the safe title area for NTSC receivers. Character width is $42.37 \mu\text{s}$, also centered on the screen, resulting in a leading and trailing $1.32 \mu\text{s}$ black border.

An optional Caption display mode, Drop Shadow, can be selected by the user through the serial port. This display mode eliminates the black box around the characters, placing a 2-dot black shadow to the right and below the character luminance dots when the 15 scan line per row mode is active. This display mode is usable in Captions, Text, and

Z86229 FUNCTIONAL DESCRIPTION (Continued)

OSD displays. Figure 5 illustrates the characters with a drop-shadow added.

Extended Features

The EIA-608 specification has defined new extended features such as optional Background and Foreground display attributes and optional Extended Characters. The Z86229 always responds to the Extended Characters, but the Extended Background/Foreground response can be controlled by the user. The Background and Foreground attributes add codes for background colors, black and transparent foreground, opaque, and semi-transparent backgrounds. The BOX signal output pin is set to a tri-state condition whenever one of the semi-transparent attribute codes is active. The external keying circuits can then use this condition to implement the intended video display.

The font for the Extended Characters are illustrated in Figure 6. The accented capital letters have been implemented by placing the accent marks above the character cell. When selected, this mode results in the accent marks being written into the character cell space of the row above. In some operating modes, the Z86229 expands the size of the overall box height by adding two additional scan lines at the top and one additional line at the bottom. There is now room for the accent marks in the topmost row and an added black

line below the descenders of any lowercase characters in the last row.

This approach is desirable because shrinking the capitals to make room for the accent mark within the character cell makes poor quality characters. In some cases, there would be no differentiation between the capital and lower case letter. Extended characters also have the advantage of minimizing the ROM size and providing a good readable font that closely matches what is normally seen in print.

In the unlikely case of a conflict between an accented capital letter in one row and a lower case descender in the same character position in the row above, the descender is given priority. The improved readability of this approach over shrunk capital letters far outweighs this potential conflict and results in a cost-effective compromise for providing a full, extended features implementation.

The Extended Characters share their address space with the OSD Graphics Characters. When a BOX display is used, the Extended Character set is in force; however, if a Drop Shadow display is used, the Graphics Characters are in force. For Caption and Text display modes, if the Drop Shadow is set, the user must also command the Z86229 to switch back to Extended Characters.

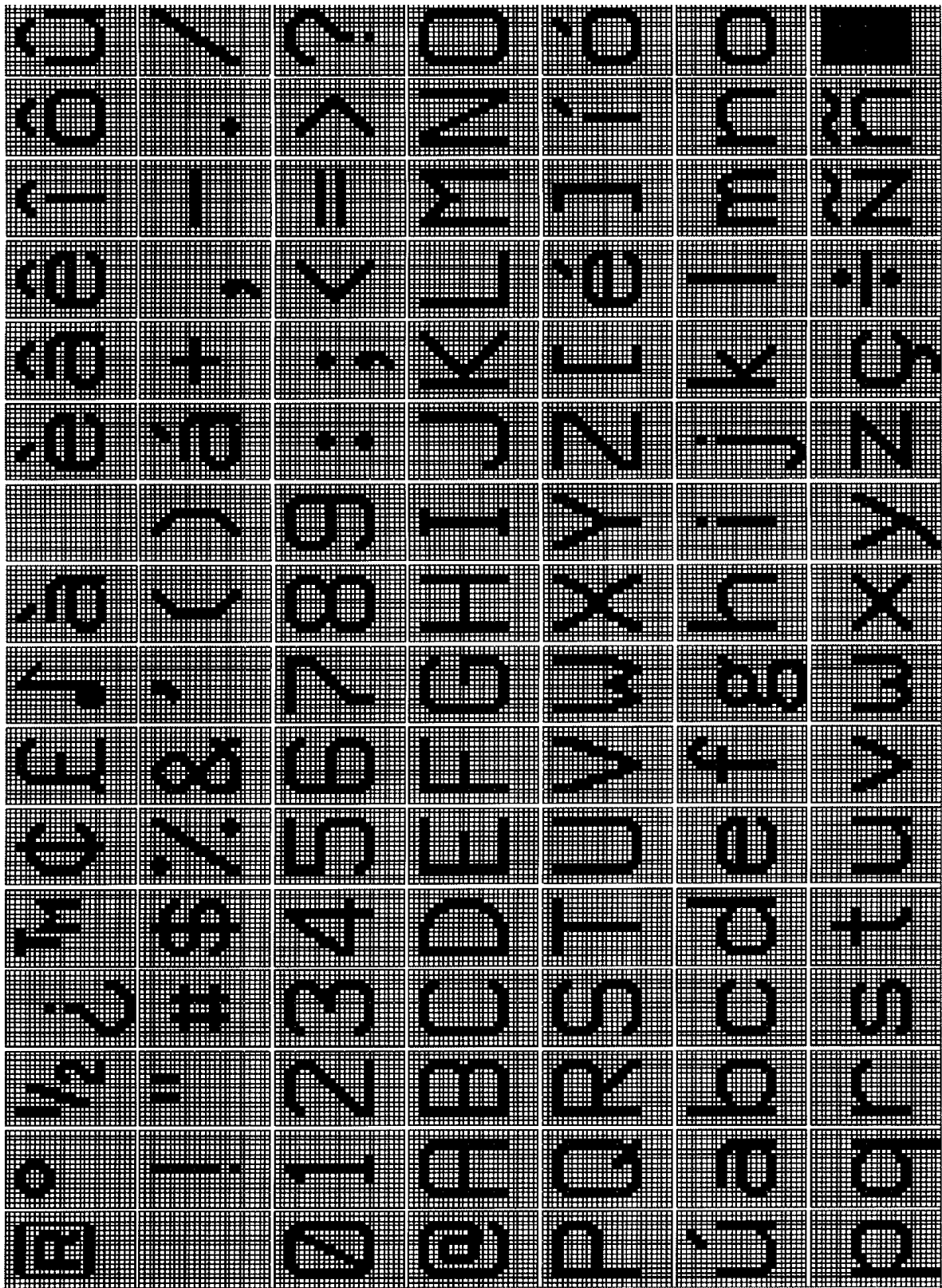

Figure 4. Z86229 Standard Character Map and Font

Z86229 FUNCTIONAL DESCRIPTION (Continued)



Figure 5. Caption Display Mode, Drop Shadow

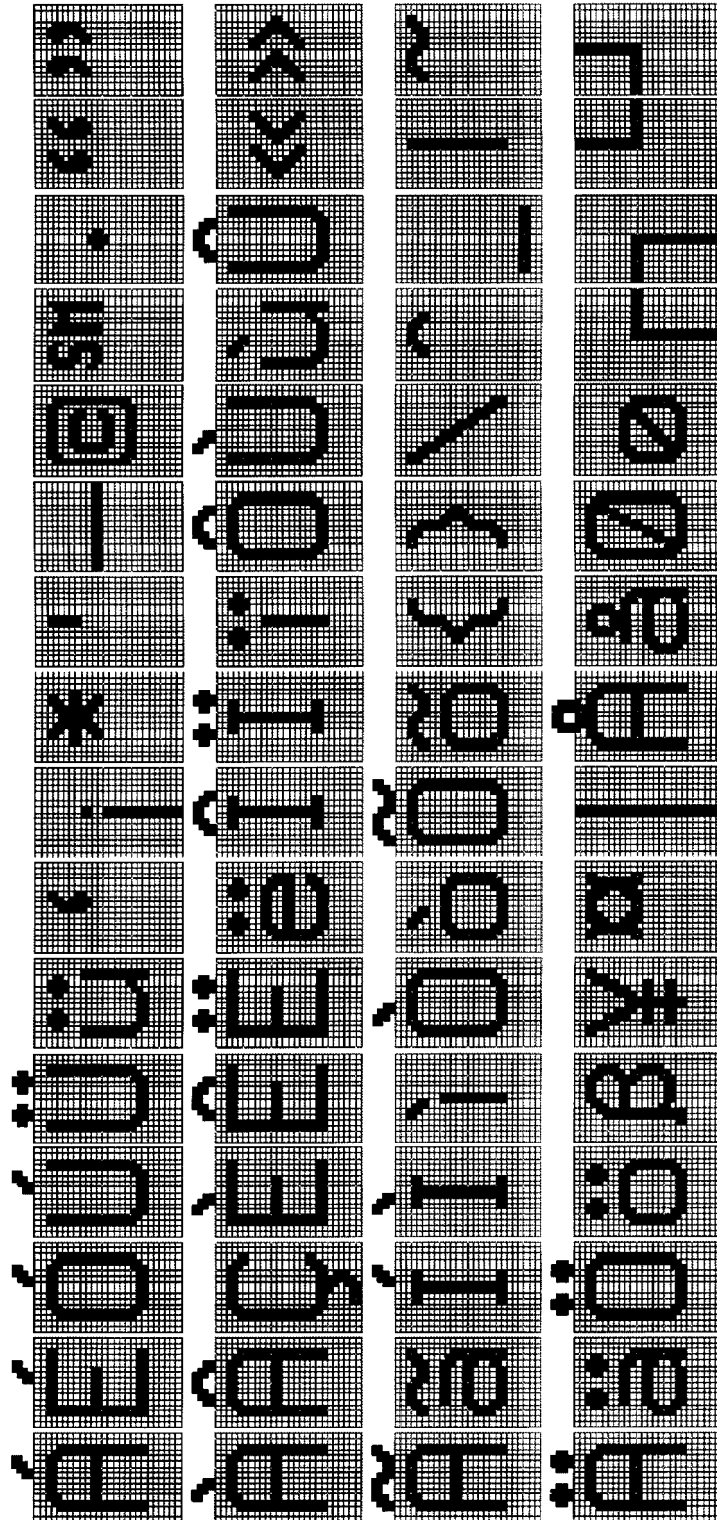

Figure 6. Extended Characters Font

Z86229 FUNCTIONAL DESCRIPTION (Continued)

Text Mode Display

When the Text mode is selected, a black box is displayed as long as a valid Line 21 code in the specified field is being detected. The Z86229 provides the option to make the box blue instead of black. This option holds for captions and text.

The default Text display mode uses a 15 row by 34 character black box. Text characters are displayed as they are received starting at the top row. Successive carriage returns move the display down successive rows until all 15 rows have been displayed. Thereafter, the text scrolls up as new characters are added to the bottom row.

If the data for the selected channel is interrupted by a command for another channel, data processing stops; however, the display remains. When a Resume Text command is received, data processing resumes and the new characters are added.

Note: The data processing begins at the position that the display row/column pointer was in at the interruption of data processing.

If a Start Text command is received, the display is cleared, and the new characters are displayed starting in row 1, column 1 (left side).

The number of display rows and the location (base row) of the Text box can be altered by the user. In this way, the user can decide how much of the screen can be covered when displaying non-program related information.

When scrolling, the display shifts one scan line per frame until a complete row has been scrolled. If a carriage return is received before scrolling is complete, the display immediately completes the "scroll" by jumping up the remaining scan lines and starting the display of the new text.

Caption Display Mode

According to FCC specifications, caption data can appear in any of the 15 display rows, but a single caption may consist of no more than 4 rows. The form of the caption display depends on the caption mode indicated by the transmitted caption command, Pop-on, Paint-on, or Roll-up. The Z86229 can display a single caption having as many as eight rows. When any of the caption display modes are selected, the screen becomes transparent

Note: Display box is only present when a caption is being displayed.

Pop-on captions work with two caption memories. One of them is normally displayed while the other is being used to accumulate new caption data. A new caption is popped-on by swapping the two memories with the End Of Caption (EOC) command. When the on-screen memory is erased, the screen is blank (transparent), and the memory defaults to the row/column pointer at row 1, column 1, and monochrome are non-underlined.

When caption mode is selected, the decoder processes data following the Resume Caption Loading (RCL) command (or the EOC). Normally, this command is followed by a Preamble Address Code (PAC) to indicate the row, column, and character attributes to be used with the following data. If no PAC is received, the data is added to the location most recently indicated by the row/column pointer prior to the receipt of the RCL command.

The Paint-on caption mode is essentially equivalent to the Pop-on mode; however, the data received after the Resume Direct Captioning (RDC) command is written to the on-screen memory rather than the off-screen memory. All the rules for PACs, Midcodes, and so on, are otherwise the same.

The Roll-up caption mode presents a "text" like display that is limited to 2, 3, or 4 rows, depending on the Resume Roll-up (RUN) command used. The PAC following the RUN command is used as the BASE ROW for the ROLL-UP display. The BASE ROW is the "bottom" row of the ROLL-UP display. In this case, the black box does not appear until characters are being displayed, and the Box is only wide enough to provide a leading and trailing box in each line. The new data appears in the bottom row, and as each carriage return is received, the row scrolls up and the new data is added to the bottom. When the number of rows indicated by the Resume command have been reached, the data in the top row scrolls off as new data is added to the bottom.

The TAB (INDENT) PAC permits placing captions starting at 4 character boundaries in any caption row. The TAB OFFSET command provides the means for adjusting the starting position for a caption at any column position in the current row.

XDS Display Modes

Two preprogrammed XDS display modes are provided. One provides information about the current program that would be of interest for "channel grazing". The second display shows the grazing packets, plus additional XDS packets which informs the viewer about the program content. Information is displayed as it is received. The displays use a drop-shadow mode with 15 scan lines per row.

The XDSG mode is the GRAZE (channel grazing) display (Figure 7). The display contains three rows of information at the top of the screen that have been formatted for easy reading. They contain the following XDS packet information:

- OSD Row 1 Network Name, Call Letters (Green)
- OSD Row 2 Program Name (Italics, Underline, White)
- OSD Row 3 Program Length, Time In Show (Cyan)

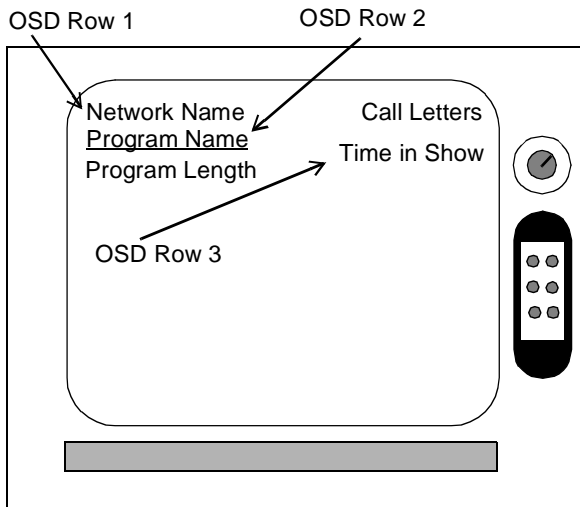

Figure 7. XDSG (Graze) Mode Sample Display

When an XDS display mode has been selected, the information is displayed as the appropriate packets are received. The display remains on-screen as long as valid XDS data continues to be received. If the 16-Second Erase Timer is enabled (the default condition), the XDS display is erased when no valid XDS data has been received for 16 Seconds. If subsequent XDS data is received with displayable packets, that information reappears on the screen. XDS data recovery can be active in the XDS display mode.

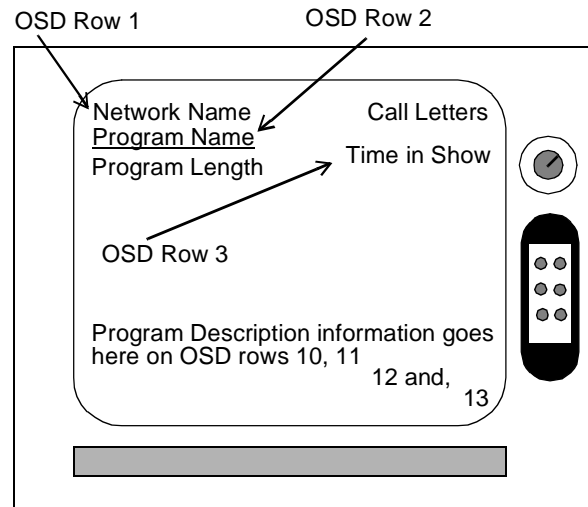

Figure 8. XDSF Mode Sample Display

The XDSF mode is the FULL (information) display (Figure 8). This display shows the same information as the GRAZE display; however, this display adds the program type as well the first four program description rows (if transmitted). Although XDS defines eight program description rows, the first four are identified as containing the most important information. The display of Program Description is limited to the first four rows. This limitation occurs because:

1. Eight rows would obscure much of the screen.
2. More than four rows are not likely to be sent due to the time required for transmission.

Because 15 scan lines per row mode are being used, rows 10–13 appear at the bottom of the screen.

- OSD Row 1 Network Name, Call Letters (Green)
- OSD Row 2 Program Name (Italics, Underline, White)
- OSD Row 3 Program Length, Program Type, Time In Show (Cyan)
- OSD Row 10 Program Description Row 1 (Yellow)
- OSD Row 11 Program Description Row 2 (Yellow)
- OSD Row 12 Program Description Row 3 (Yellow)
- OSD Row 13 Program Description Row 4 (Yellow)

The XDS display mode is turned off by selecting a different display mode.

Display Erase and Autoblanking

The display is erased in the Text mode by the Start Text command (but the box is maintained) and in the CAPTION mode by the Erase Displayed Memory (EDM) command. The non-displayed memory can be erased by the Erase Non-displayed Memory (ENM) command.

Four other events can also cause the display to be erased.

1. The first action is a change in the display mode, such as from CC1 to T1 or CC1 to XDSF. A change in display mode clears the memory and the display.
2. A loss of video lock, such as on a channel change, can cause the screen to be cleared. The current active display mode is not changed. For example, if CC1 is selected and ON before the channel change, the device will remain in the CC1/ON state after the channel change.
3. The third action that clears the displayed memory is when the autoblanking circuit is activated. The autoblanking circuit monitors the presence of a Line

Z86229 FUNCTIONAL DESCRIPTION (Continued)

21 waveform in the video field corresponding to the data channel selected for display. The decoder is held in the Decoder OFF (TV) state until a Line 21 waveform is continuously detected for a period of 0.5 seconds. After a valid Line 21 waveform has been detected for 0.5 seconds, and assuming that the user has selected the Decoder ON state, the normal display for the data channel selected is presented. The autoblanking circuit is not activated again until a valid Line 21 waveform has been lost for 1.5 seconds. Any data received during the 1.5-second period resets the counter. As a result, autoblanking is only activated on continuous loss of the Line 21 waveform for 1.5 seconds.

Note: A valid Line 21 waveform is defined as the presence of a 7-cycle run-in clock, in addition to a start bit on Line 21 of the field being examined.

4. The fourth method of clearing the screen is by the action of the 16-Second Erase Timer. This function is only active when a CAPTION or XDS display mode has been selected. If no data is received for the display channel selected for a 16-Second period, the on-screen memory is erased; however, the decoder is still on the selected channel (with the decoder ON), allowing data for the selected channel to be displayed.

Z86229 FEATURE SET

The primary features of the Z86229 are summarized below. More complete descriptions can be found in later sections of this document.

VBI Data Processing

The Z86229 extracts Line 21 data from the incoming video signal. All data channels in both video fields are supported. Incorporating the VBI decoding feature, the Z86229 can perform the following:

- Process data from both fields of Line 21 simultaneously
- Output XDS data through the serial port while displaying selected data
- Output XDS data through the serial port raw or filtered
- Select XDS filters from a list of pre-programmed values including Program Rating and Time of Day/Local Time
- Select NTSC or PAL operation

The video data extracted from Line 21 may be displayed in different ways according to the user selection and the type of data. Display choices include:

- Ten different Line 21 data-display modes; CC1–CC4 and T1–T4, plus two standard templates for XDS displays
- Pop-on, Paint-on, and Roll-up CAPTION displays
- Text display default as a full screen, 15 row display
- User can vertically reduce and reposition the Text display as required
- Color or Monochrome display mode selectable
- XDSG Display Mode (channel grazing): automatic display of Network Name, Call Letters, Program Name, Program Length, and Time In Show data packets
- XDSF Display Mode (full information): automatic display of XDSG Display Mode information in addition to Program Type (only basic types) and Program Description

General Purpose OSD Modes

Apart from displaying data extracted from Line 21 of the incoming video, the Z86229 can also display information

supplied through its serial port. This condition is referred to as On-Screen Display (OSD) mode. This mode provides:

- Programmable Full Screen OSD: 15 display rows by 32 character columns
- Graphics characters
- Double-High and Double-Wide characters
- Fully programmable display positioning (information may be placed anywhere on the screen)
- Accepts externally supplied (or internally generated) VSYNC to enable OSD even when no video is present

Character Set

The Z86229 has a new character set with extended features, such as:

- New font with descenders on lower case letters
- Optional display mode using the drop-shadow font (in other words, fringing appears on each character rather than a solid, “black box” background)
- EIA–608 Extended Characters
- EIA–608 Background and Foreground attributes
- Special framing and graphics characters for OSD display
- Double-High and Double-Wide character display for OSD
- Fifteen scan lines per character row for OSD and Text

Note: Contact the nearest ZiLOG Sales office for additional information on how to define your own custom OSD character set.

Serial Communications Interface

Communications and control of the Z86229 is possible through a serial control interface. Two Serial Control Modes are available with the Z86229 performing as a slave device. These modes are:

1. A two wire, I²C interface.
2. A three wire, Serial Peripheral Interface (SPI).

A total of five device pins are dedicated to the serial control port function. These pins are indicated in Table 7.

Z86229 FEATURE SET (Continued)

Table 7. Z86229 Serial Control Signals

Signal	SMS	SCK	SDA	SDO	SEN
Pin #	6	15	14	16	4
I/O	I	I	I/O	O	I
I ² C	0	CLK	Data	NA	1
SPI	1	CLK	Data In	Data Out	Enable

Notes:

SMS = Serial Mode Select High = SPI and Low = I²C.
 SCK = Serial port clock for either Serial Mode.
 SDA = Serial port data for I²C Mode and Data In for SPI Mode.
 SDO = Serial Data Out for SPI Mode. Not used in I²C Mode.
 SEN = SPI Mode Enable signal. Must be High for I²C Mode.

I²C Mode. The I²C port on the Z86229 always acts as a slave device. I²C Mode is selected by bringing the SMS pin Low and the SEN pin High. SEN must remain High whenever I²C mode is required. If the SEN pin is brought Low, with the SMS also Low, the part is reset. SDA and SCK are the data and clock lines of the I²C port, respectively. During I²C mode operation, the V_{IN}/INTRO signal (pin 13), can be configured to generate interrupt requests to the master device on selected events (see Note paragraph page 22).

SPI Mode. SPI Mode is selected by making the SMS pin High. In SPI mode, the Z86229 acts as a slave device. All communications are clocked in and out as 8-bit bytes. SCK is the serial clock (input), SDA is Data-In, and SDO is Data-Out. The SEN pin enables communication when High. When Low, the SDO pin is tri-stated.

When SEN is brought High, the part is synchronized and waiting for a Command. If SEN is tied High, the part can also be synchronized by a command string. During SPI mode operation, the V_{IN}/INTRO signal (pin 13) can be configured to generate interrupt requests to the master device on selected events

Caution: When the SEN and SMS pins are made Low simultaneously, the part is reset.

Interrupt Generation. The V_{IN}/INTRO signal (pin 13) can be configured to provide an interrupt output on selected events. The configuration of V_{IN}/INTRO (pin 13) is user programmable to be either:

1. An INPUT pin for acceptance of an external VSYNC timing signal.
2. An OUTPUT pin for interrupt generation on selected events.

Note: Configuring V_{IN}/INTRO as an output for interrupt generation is particularly useful when implementing the Program Blocking feature with the Z86229 in TVs and VCRs. In this configuration, Pin 13 is used to interrupt the host processor when the XDS Program Rating data packet is found. As a result, the host processor is not burdened with monitoring or filtering the line 21 data stream. The Z86229 filters the Line 21 data stream for the host processor, and generates an interrupt only when the required packet is found.

Setup and Operational Control

The Z86229 is extremely flexible and fully programmable through its serial communication port. The following tables provide a partial list of User-Programmable Features, User Selectable Display Modes, and Default Conditions upon Reset.

Z86229 Programmable Features

- Decoder ON/OFF
- TV scan lines per OSD row (13 or 15 lines)
- EIA-608 extended attributes ON/OFF
- OSD drop shadow ON/OFF
- Color/Monochrome
- OSD Horizontal start position
- Text box size (# of rows)
- Text box starting row position
- NTSC or PAL
- Vertical Lock Source: Video or External V_{IN}
- XDS Data Output, Raw or Filtered
- H-lock Source: Video or External HIN

In addition to the programmable features just listed, the Z86229 offers a choice of eleven display modes for user selection.

Table 8. Z86229 Display Modes

Display Mode	Display Data	NTSC Field ¹	Language ²
CC1	L21 Closed Captions	1	I
CC2	L21 Closed Captions	1	II
CC3	L21 Closed Captions	2	I
CC4	L21 Closed Captions	2	II
T1	L21 Text	1	I
T2	L21 Text	1	II
T3	L21 Text	2	I
T4	L21 Text	2	II
XDSF	XDS	2	N/A
XDSG	XDS	2	N/A
OSD	User Defined via Serial Port	N/A	N/A

Notes:

1. In NTSC-interlaced mode, there are two fields, or horizontal pixel-display lines, exhibiting alternate refreshes to the display.
2. Language I refers to synchronous captioning, and language II refers to supplementary captioning.

The Z86229 is initialized on RESET to the following default conditions:

Table 9. RESET Default Conditions

Parameter	Reset Condition
Display Channel	CC1
Decoder	OFF
Text Size	15 rows
Lines/Row	13
Background	BOX
EIA-608 Extended Attributes	ON
Data Outputs	OFF
Video Standard	NTSC
Data Outputs	OFF
VCO Lock	Video
BOX Timing	13.5 μ sec
Vertical Lock	Video
V _{IN} /INTRO	INTRO & Disabled
Horizontal Lock	Video
Color/Mono	Color
OSD Display	Drop Shadow 15 lines/row

SERIAL COMMUNICATIONS INTERFACE

Commands and data are sent to and from the Z86229 through its serial communications interface. Two Serial Control Modes are available. One mode is a two wire I²C bus interface. The other serial mode is a three wire, synchronous serial peripheral interface (SPI). In both cases, the Z86229 acts as a slave device.

The serial communications port is the path for setting the configuration and operational modes of the device. It is also the port for outputting the recovered XDS data and for inputting the OSD data for display.

When the Vertical Lock = VIDEO, the V_{IN}/INTRO (pin13) is configured as an output, providing the INTRO signal. This interrupt operation is available in either serial control mode.

The Z86229 is able to generate an interrupt on the occurrence of any set of specified events. The master device clears the interrupt by writing to the Interrupt Request Register.

I²C Bus Operation

The serial control mode in use is selected by the state of the SMS pin. When SMS is set Low, the Z86229 is in the I²C mode. In this mode, the Z86229 also supports a bidirectional two wire bus and data transmission protocol. The bus is controlled by the master device, which generates the serial clock (SCK), controls the bus access, and generates the Start and Stop conditions. The SDA pin is the bidirectional data line. In this mode, the SDO output is not used, and the pin is in its high-impedance state.

The Z86229 can receive or transmit data under the control of a master device. Remember that the Z86229 is a slave device. Communication is initiated when the master device sends the start condition followed by the Z86229 Slave Address Read byte (29h or 2Bh) or Slave Address Write byte (28h or 2Ah). The Z86229 responds with an Acknowledge. The I²C RD/nWR bit is the Least Significant Bit (LSB) of the I²C addresses (Table 10).

Table 10. Z8612 I²C Slave Addresses*

	READ	WRITE
1st I ² C Address	29h	28h
2nd I ² C Address	2Bh	2Ah

Note: *When the SMS and SEN pins are both Low, the part is in the Reset state. Therefore, the SEN pin can be used to reset the part while in the I²C mode. The SEN pin may be tied to a NReset signal or tied High if no reset is required. The I²C Address is selected by pin 1 input. When pin 1 input is Low(0), it selects the 1st address. When pin 1 input is High(1), it selects the second address.

The I²C Bus Protocol

Under the I²C bus protocol, the following conditions must be present:

1. Data transfer can only be started when the bus is not busy.
2. During data transfer, data transitions must not occur while the clock is High.

Bus Conditions are Defined as:

Not Busy. Data and Clock lines are both High.

Start. A High to Low transition of an SDA line while the SCK line is High.

Stop. A Low to High transition of an SDA line while the SCK line is High.

Acknowledge. When addressed, the receiving device must output an acknowledge after the reception of each byte. The master device must generate the clock for the acknowledge bit. Acknowledge is SDA=Low. A Not ACKnowledge result (NACK) is SDA=High.

Data. The data (SDA) is output by the transmitting device on the falling edge of SCK, MSB first. The receiving device reads the data, MSB first, on the rising edge of SCK.

Communication with the Z86229 is initiated when the master device sends the Z86229 slave address following a start condition. The Z86229 has a single preset, consisting of a seven-bit slave address. The Z86229 responds with an acknowledge. The eighth bit of the slave address is driven High for Read operations and Low for Write operations.

Writing to the I²C Bus

All write commands are either one- or two-byte commands. The Z86229 is enabled when a Start condition, followed by its Slave Address Write byte, is received. The Start condition is disabled when it deems the command to have been completed, or when a Stop condition occurs. A new Start condition without a Stop condition begins a new sequence. Therefore, successive commands may be executed by successive strings of “Start—Slave Address—Command” sequences without any intervening Stop condition being sent.

Note: The number of data bytes to be received by the Z86229 is inherent in the command. The Z86229 responds with the acknowledge signal only for the number of bytes expected. If the master writes more bytes than expected, there is no acknowledge for the extra bytes.

A write command to the Z86229 should always be preceded by executing a Status read to verify that the Z86229 is not busy. The Status register data is output immediately following the reception of the Slave Address Read. If the RDY bit is set, the master device can initiate its write sequence, always beginning with the Start condition. The first byte of a two-byte command is always written first.

An example of the master's sequence for writing a two-byte command (after RDY had been checked) would be:

Start
Slave Address Write/Slave ACK
CMD (master)/ Slave ACK
DATA (master)/Slave ACK
Stop

I²C Two-Byte Write (Command & Data)



I²C One-Byte Write (Command)

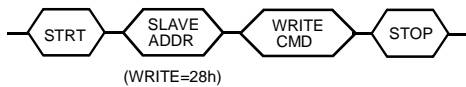

Note: A Status Register RDY bit must be read and checked prior to the STRT condition of either WRITE sequence above. See the One-Byte Read (Status Only) in Figure 10 for more information on reading the Status Register.

Figure 9. I²C Bus WRITE (Command)

Reading Data Using the I²C Bus

With the exception of the Serial Status (SS) register, which may be read at any time, each read operation must be set up before the data can be read from the serial output registers of the Z86229. Data is set up for a read operation either automatically or manually. The XDS data reads are set up automatically upon recovery by setting a valid XDS FILTER register selection. All other data read operations must be set up manually using the READ SELECT commands RDS1 and RDS2. These commands load the selected data byte or pair of bytes into the serial output register(s), setting the SS register RD2 bit according to the number of data bytes requested. The SS register DAV bit is also set at that time to indicate the availability of data.

The Z86229 I²C Bus supports one-, two-, and three-byte read sequences. All read sequences output the SS register as the first output byte. If the serial status DAV bit is set, a two or three byte read sequence can then be initiated, beginning with a new STRT condition.

Caution: If the DAV bit is not set, the I²C master device should not attempt to read any data bytes. Attempting to read data bytes from the I²C master device may cause a loss of data from the Z86229 output registers.

The number of data bytes available is indicated by the state of the RD2 bit of the serial status. In a typical read operation, the status byte is read, and the DAV and RD2 bits are examined. If one or two data bytes are available, the data is read in sequence, separated by acknowledges.

Note: In all I²C Read operations (one, two, and three byte as defined in Figure 10) the most recent byte read from the Z86229 should be acknowledged by the master with a NACK (Not ACKnowledge). It is also necessary to read all available data in a read operation to clear the DAV bit and permit subsequent reads. The DAV is cleared by the master clocking out of the eighth bit of the most recent data-byte read. The DAV is never cleared by just reading the SSB (one-byte read) alone. All data is first output as MSB.

The slave's sequence for reading two data bytes (total of three bytes including SSB) from the Z86229 is given as:

Start
Slave Address Read/Slave ACK
SS Byte/Master ACK
Byte (slave)/Master ACK
Byte (slave)/Master NACK
Stop

I²C One-Byte Read (Status Only)

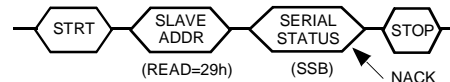

I²C Two-Byte Read (Status & Data1)

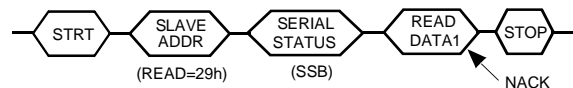

I²C Three-Byte Read (Status, Data1, & Data2)

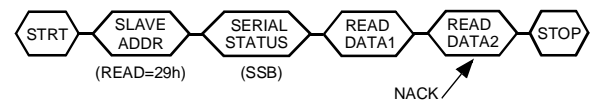

Note: In all I²C Read operations defined herein, the last byte read from the Z86229 must be acknowledged by the master with a NACK (Not ACKnowledge).

Figure 10. I²C Bus READ (Command)

SERIAL COMMUNICATIONS INTERFACE (Continued)

Clock and Data Transitions. The SCK and SDA bus lines are normally pulled High with a resistor. Data on the SDA bus may only change during SCK Low time periods. Data changes during SCK High periods indicate a start or stop condition (Table 11) defined as:

Start Condition. A High-to-Low transition of SDA, with a SCK High as a start condition which must precede any other command.

Stop Condition. A Low-to-High transition of SDA, with a SCK High as a stop condition which terminates all communications.

Acknowledge. All address and data words are serially transmitted to and from the Z86229 in eight-bit words. The instance of a ninth bit generates an acknowledge. The device acknowledges the data by pulling the SDA bus Low during the ninth bit. A Not Acknowledge (NACK) is given by SDA=High during the ninth clock time.

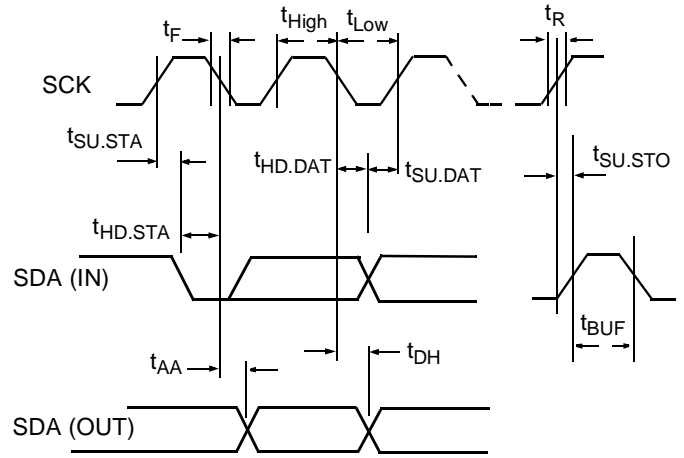

Figure 11. I²C Serial Timing

Table 11. I²C Serial Timing Min/Max

Symbol	Parameter	Min	Max	Units
f_{SCK}	Clock Frequency		100	kHz
t_{LOW}	Clock Pulse Width Low	4.7	-	μ s
t_{High}	Clock Pulse Width High	4.0	-	μ s
t_R	SDA and SCL Rise Time	-	1.0	μ s
t_F	SDA and SCL Fall Time	-	300	ns
t_{AA}	Clock Low to Data Out Valid	0.1	3.5	μ s
t_{BUF}	Bus Free Time	4.7	-	μ s
$t_{HD.STA}$	Start Hold Time	4.0	-	μ s
$t_{SU.STA}$	Start Set-up Time	4.7	-	μ s
$t_{HD.DAT}$	Data In Hold Time	0	-	μ s
$t_{SU.DAT}$	Data In Set-up Time	250	-	ns
$t_{SU.STO}$	Stop Set-up Time	4.7	-	μ s
t_{DH}	Data Out Hold Time	100	-	ns
t_l	Input Filter Time Constant		100	ns

SPI Bus Operation

When the SMS pin is High, the Z86229 is in the SPI serial control mode. The clock line should be tied to the SCK pin. The DATA IN signal and DATA OUT signal from the master device should be connected to the SDA and SDO pins, respectively. The SEN pin is used to select the Z86229 when there are multiple peripherals on the bus.

As noted above, when both the SMS and SEN pins are Low, the part is in the RESET state. When the SPI bus is used in a dedicated fashion between the master and the Z86229, both the SEN and SMS pins would be tied High. The RESET

function would require that both of these pins be tied to the NReset signal. To ensure synchronization, the master device should send the serial synchronization signal after the reset is released.

When the SPI mode is used in a multiple peripheral environment, the SEN pin is used as the Z86229 enable signal. The SMS could then be used for the NReset signal as long as the reset was only applied while SEN is Low. In this case, there would be no requirement for the master device to send a serial synchronization string after reset if there was at least 100 ns between the end of the reset and the start of the port enable.

A command string can be interrupted at any time. The port is resynchronized by sending the Serial Sync signal or by activating the rising edge of SEN.

The SPI bus is a three-wire bus when used in a dedicated manner between the Z86229 and the master device. If other peripherals are connected to the bus, then the SEN pin must be used to place this device on the bus at the appropriate time. When SEN is Low, the SDO pin becomes tri-stated, transitioning on the SCK and SDA pins, which, as a result, are ignored.

If data output is not required from the Z86229, then control can be accomplished using only the SCK and SDA pins. Because this type of operation precludes the ability to check the RDY bit, it is very important that commands be spaced by at least two frames (66 msec) to ensure that one command has been executed before initiating another.

The bus is controlled by the master device, which generates the serial clock (SCK) and initiates all actions. Clocking data in on the SDA simultaneously produces a data out on the SDO. The master should always check for the appropriate handshake signal before executing any command other than a NOP.

Writing to the part requires that the RDY bit be set, while reading from the part requires checking the SS register to see if the DAV bit is set. Both of these bits are contained in the Serial Status (SS) register. Writing to the Z86229 concurrently outputs the contents of the SS register, MSB first, unless other data is being output as a result of one of the READ commands. If it is required to read the SS without executing a command, the NOP command can be written at any time, even if the serial status RDY bit is not set.

The RDY status bit is driven onto the SDO pin between command transmissions. The controlling MCU can test the state of this pin, without clocking, in order to determine if subsequent serial transfers are possible. The DAV bit can only be checked by outputting the contents of the SS register.

Writing to the SPI Bus

All write commands are either one or two-byte commands. The number of data bytes to be received by the Z86229 is inherent in the command. If the master device writes more bytes than expected, the command may be overwritten or corrupted by the extraneous bytes.

A write to the Z86229 should always be preceded by executing a Status read to verify that the device is ready. The serial status is output by the device, concurrent with the input of any command byte. If the RDY bit of the serial status register is set, the master device can write a new command.

The command and data bytes are written MSB first. Typically, the first byte of a two-byte command is sent first. The bits are clocked into the Z86229 by placing the data on the SDA input and bringing the SCK High.

Reading Data Using the SPI Bus

With the exception of the SS read, each read operation must be set up before the data can actually be read from the serial output registers of the device. Data is set up for a read operation either automatically or manually. The XDS data is set up for a READ automatically upon recovery by setting a valid XDS FILTER register selection. All other data read operations must be set up manually, using the READ SELECT commands RDS1 and RDS2. These commands load the selected data byte (or pair of bytes) into the serial output registers, set the SS register RD2 bit according to the number of data bytes requested, and set the serial status DAV bit to indicate the availability of data.

The Z86229 SPI Bus supports two and three byte read sequences. In SPI mode, the SS must be read before a read sequence is started, so that the DAV and RD2 bits can be checked. The number of data bytes available is indicated by the state of the RD2 bit. The special command, READ1 or READ2, is then used to read the one or two available data bytes. The serial status is clocked out during the write of the READ1 or READ2 command. The data byte or bytes are then clocked-out in sequence, MSB first, while the NOP commands are written into the device. Data bits are clocked-out on the rising edge of SCK. All available data bytes must be read to clear the DAV bit and permit subsequent reads.

The SPI Bus Protocol

The SPI Bus Protocol is defined as follows:

1. The first bit of the first output byte is driven out on the SDO. This action is followed by the rising edge of SCK on the last bit (LSB) of the READ1 or READ2 command.
2. A three-wire bus is defined with a Clock signal on the SCK pin, a Serial Data Input on the SDA pin, and a Serial Data Output on the SDO pin.
3. The SEN pin Low disables the port, placing the SDO pin in a tri-state. Signal transitions on SCK and SDA are ignored.
4. The SEN pin High enables the port for operation.
5. The SEN and SMS pins Low indicate a hardware reset for the part. These pins must be held Low for at least 100 ns.
6. Serial synchronization can be established by clocking in the minimum required SSR string of FFh, FFh, FEh. More than two bytes of FFh may be input, but the string must end with FEh.

COMMANDS

Serial Port Commands

The majority of the Z86229 commands are common to both the I²C and SPI modes. In the I²C mode, the commands must be contained within the specified sequence (Start—Slave Address—etc.).

Note: In the following Command descriptions, the letter “h” following a command code designates hexadecimal notation.

Reset

RESET = FBh, FCh, 00h. RESET is a three byte command sequence in SPI or I²C mode. The RESET command establishes all the specified default settings in the device, but it does not reset the serial port itself. This sequence can be entered without RDY being set.

No Operation

NOP = 00h. NOP is a one-byte command for use in SPI or I²C mode. The NOP command does not affect the status of the RDY bit in the Serial Status (SS) register and can be executed independent of the RDY status.

Serial Sync Bytes

SSB = FFh, ..., FFh, FEh. Serial Sync Bytes are used in SPI mode only. This command actually consists of a string of single-byte commands in the form FFh, ..., FFh, FEh. SPI mode communications can be synchronized by sending a synchronizing data string to the part. This string should consist of at least two SSB bytes of FFh, followed by one SSB byte of FEh. At the end of the FEh byte, the port is ready for use.

Table 12. Basic Serial Commands

Serial Command	Command Code	Notes
RESET	FBh, FCh, 00h	SPI or I ² C
NOP	00h	SPI or I ² C
SSB	FFh, ..., FFh, FEh	SPI mode only

Caption/Text Display Mode Commands

CPTX = 10h–1Fh. These caption and text display-mode commands are one-byte commands that select the Line 21 data stream (caption or text) for display.

Bit	CM7	CM6	CM5	CM4	CM3	CM2	CM1	CM0
	0	0	0	1	FLD	CPTX	LANG	DONOF
	R/W	R/W	R/W	R/W	R/W	R/W	R/W	R/W

Figure 12. CPTX—Caption/Text Display (CPTX = 10h–1Fh)

A data channel can be selected for display with the display either enabled (DEC ON) or disabled (DEC OFF). All these commands turn off the active XDS display mode. Table 13 summarizes the device’s caption and text display modes and the proper command code to activate them.

Table 13. Caption and Display Commands

CPTX Command	CPTX Command Code	
	Decoder ON	Decoder OFF
CC1	17h	16h
CC2	15h	14h
CC3	1Fh	1Eh
CC4	1Dh	1Ch
T1	13h	12h
T2	11h	10h
T3	1Bh	1A
T4	19h	18

XDS Display Mode and 16-Second Erase Timer Commands

XDS DISP = 20h–27h. XDS Display commands are one-byte commands. These commands control the selection of XDS display modes and the state of the 16-Second Erase Timer. The 16-Second Erase Timer is active only for caption and XDS display modes. The 16-Second Erase Timer has no affect on Text mode displays.

Table 14. XDS Display Commands*

XDS Display Command	XDS Display Command Code	
	16 Sec Tmr ON	16 Sec Tmr OFF
	XDSG	23h
XDSF	21h	25h
16-Second Erase Timer	20h	24h

Note: *Changing the ON/OFF state of the 16-Second Erase Timer has no affect on the current display mode in operation.

Read And Write Commands

Read Selects. There are two Read Select commands (RDS1 and RDS2) in the Z86229. Each command is one byte in size and indicates that a read should take place. RDS1 specifies that one byte is read from the Z86229; likewise, RDS2 indicates that two bytes are read.

RDS1 = 40h–47h. RDS1 is a one-byte command used to initiate a one-byte read sequence. This action is performed by moving the contents of the register identified by the address field (AD00:02) of the command to the output register. Addresses 0h–7h are valid in the RDS1 command field AD00:02.

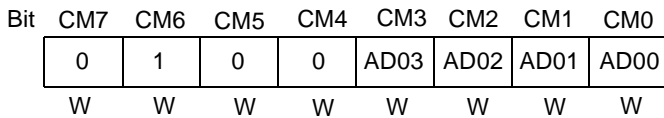

Figure 13. RDS1–Read One Byte (RDS1 = 40h–47h)

RDS2 = 60h–66h. RDS2 is a one-byte command which is used to initiate a two-byte read sequence. This action is performed by moving the contents of the two consecutive registers, starting with the one identified by the address portion of the command (AD00:AD02), to the output registers, setting the RD2 bit in the SS register. Only Addresses 0h–6h are valid in the RDS2 command field AD00:02.

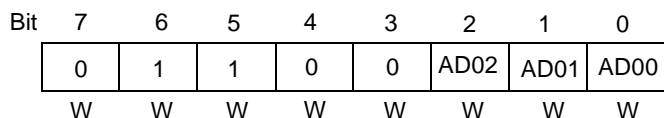

Figure 14. RSD2–Read Two Bytes (RDS2 = 60h–66h)

Note: For XDS data recovery, when the XDS Filter Register (see Internal Register section) is enabled for the packets, the Z86229 automatically establishes the two-byte recovery mode, moving the recovered data bytes to the output register.

Reading Data From The Z86229

READ1 = F8h. This command reads one byte in the SPI mode.

READ2 = F9h. This command reads two bytes in the SPI mode.

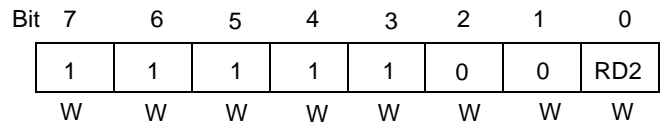

Figure 15. READx–Read x Bytes (READ1/2 = F8h/F9h)

The READx commands do not affect the status of the RDY bit in the Serial Status (SS) register, and can be executed independent of the RDY status.

In both serial communications modes, the DAV bit in the SS register indicates when the data is available. When the RD2 bit is Low, the DAV is cleared on the rising edge of SCK at the LSB of the first data byte. When the RD2 bit is High, the DAV is cleared on the rising edge of SCK at the LSB of the second data byte. The RD2 bit is only valid if the DAV is High.

Reading in the I²C mode is selected by the R/NW bit in the Slave Address byte. The first byte after the Slave Address byte is SS followed by the data in output buffers (A and B, respectively). If the instruction being executed is a one-byte read, then buffer A contains the read data and buffer B contains all ones.

Writing to the Z86229

WRxx = C0h–DFh

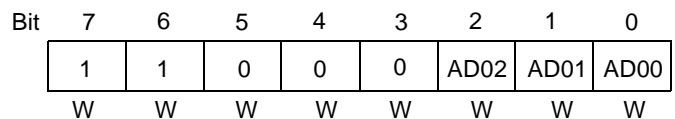

Figure 16. WRxx–Write Register xx (WRx = C0h–DFh)

COMMANDS (Continued)

The WRITE commands require two bytes to execute. The first byte is the write command. This byte includes the Z86229 register address (AD00:04). The second byte is the data to be written.

OSD Display Mode Commands

OSD commands are one and two-byte commands. They are used to control the loading of data for OSD display and their

presentation to the screen. Normally, the OSD display mode uses 15 TV lines per display row to enhance the screen appearance. The following tables summarize the single- and two-byte control commands for the Z86229 On-Screen Display.

Table 15. Single-Byte OSD Display Mode Commands

Command Name	Code	Command Function
RETURN	30h	Carriage return for OSD when in TEXTSET mode
CLRE	31h	OSD equivalent of delete to end of row (DER)
TEXTSET	32h	Establishes a Text type of OSD display
POPSET	33h	Establishes a pop-on type of OSD display
FLIP	36h	OSD equivalent of pop-on caption, end of caption (EOC)
OEDM	37h	OSD equivalent of erase displayed memory
OENM	38h	OSD equivalent of erase non-displayed memory

Table 16. Two-Byte OSD Display Mode Commands

Command Name	First Byte	Second Byte	Command Function
POP ROW SEL (with Double-High Option)	A0h	rrh	This command sets the display row and moves the cursor to char column 1. The low order nibble of rr designates the display row. Bit 5 of rr specifies a Double-High row. For example, rr=0Eh would select display row 14; rr=23h would select display row three, Double-High.
PHYS ROW SEL	A1h	rrh	This command sets the physical row, where the low order nibble of rr designates the physical row. rr can be any value from 00h to 0Fh.
CURSOR SET	A2h	cch	This command places the cursor at the character column position designated by cc, which can be any value from 00h to 20h (column 0–32). Zero is the PAC space.
WRITE CHAR	A3h	ddh	This command writes the data byte dd to the current cursor location and then increments the cursor.
WRITE MAP	A4h	rrh	This command maps the current physical row to the display row designated by the low nibble of the rr byte. Bit 4 of rr=1 enables display of the row. Bit 5 of rr=1 indicates a Double-High row.
WRITE CHAR DBL WIDE	A5h	ddh	This command is the same as the A3 command, but specifies a Double-Wide character.
WAIT	A6h	nnh	This command sets the RDY bit of SS, suspending the serial command execution for approximately the number of frames designated by the nn byte.

Figure 17 illustrates the two different character sets, Graphics or Extended, that share the address space C0h–FFh. The

Graphics Character set is in force when the OSD display is in Drop-Shadow mode (the default condition).

The two-byte commands (GRAPHICS and EXTENDED) above can be used to switch from the Graphics Characters to the Extended Characters and vice versa.

Note: An OSD screen can only use one set at a time.

	Ø	1	2	3	4	5	6	7	8	9	A	B	C	D	E	F
C	À	Á	Â	Ã	Ä	Å			È	É	Ê	Ë	Ï			
D	Ì	Í	Î	Ï	Ò	Ó	Ô	Õ	Ù	Ú	Û	Ü	Ö			
E				ä	å	ä						ë				
F	ì			ï	ò			ö	ù			ü	ö			

	Ø	1	2	3	4	5	6	7	8	9	A	B	C	D	E	F
C																
D																
E																
F																

Figure 17. Z86229 Graphics or Extended Character Set

INTERNAL REGISTERS

Information controlling the setup and operation of the Z86229 are maintained in several registers. The user may read or alter the contents of these registers as required.

Serial Status (SS) Register Address = Not Required

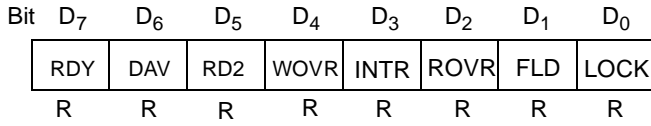

Figure 18. Serial Status Register
(Address not required)

D₀–LOCK. Active High, indicating that the internal sync circuits are locked. This bit may be used as an indication of the presence of a video signal.

D₁–FLD. This bit signals the current video field. Low = Field 2, High = Field 1.

D₂–ROVR. Active High, indicating that the data available in the output buffer has not been read out and, new data has been written over it.

D₃–INTR. Active High, indicating that an interrupt other than DAV is pending.

D₄–WOVR. Active High, indicating a serial input data overrun has occurred.

D₅–RD2. Signals the number of bytes available for output. Low = 1 byte, High = 2 bytes.

D₆–DAV. Active High, indicating that data is available to be read out.

D₇–RDY. Active High, indicating that the port input buffer is empty. Only the NOP, RESET, and READ instructions may be sent if RDY is Low.

Configuration Register Address = 00h

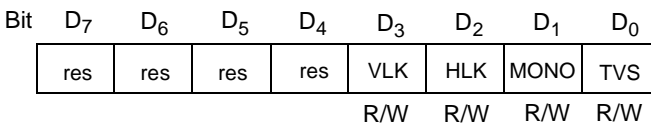

Figure 19. Configuration Register (Address = 00h)

D₀–TVS. This bit selects the television standard. High selects PAL and Low selects NTSC. The default is NTSC.

When PAL is selected, the display defaults to 15 TV scan lines per display row.

D₁–MONO. This bit selects monochrome operation. Active High indicates that the character luminance is output on all three color pins (RGB). The default is Low, selecting COLOR operation.

D₂–HLK. This bit selects the horizontal signal source to be used to lock the VCO (Low = Internal, High = HIN). The default is Internal.

D₃–VLK. This bit selects the vertical signal source to be used to establish a vertical sync lock (Low = Internal, High = V_{IN}). The default is Internal. When the Internal lock is enabled, the V_{IN}/INTRO pin defaults to the INTRO output mode. Interrupts should not be selected in the Interrupt Mask register if the VLK mode is used.

D₄–D₇. Reserved.

Display Register Address = 01h

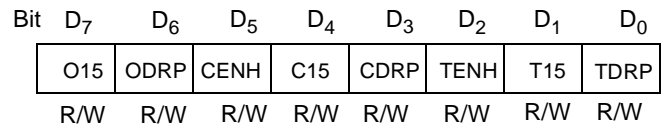

Figure 20. Display Register (Address = 01h)

D₀–TDRP. This bit selects Drop Shadow or Full Box in Text mode (High = DROP SHADOW and Low = BOX). The default is Low.

D₁–T15. This bit selects the number of TV lines per character row in a Text display (High = 15 lines/row and Low = 13 lines/row). The default is Low.

D₂–TENH. This bit enables Enhanced Attributes for a Text display (High = Disabled, Low = Enabled). The default is Low.

D₃–CDRP. This bit selects Drop Shadow or Full Box in CAPTION mode (High = DROP SHADOW and Low = BOX). The default is Low.

D₄–C15. This bit selects the number of TV lines per character row in a CAPTION display (High = 15 lines/row and Low = 13 lines/row). The default is Low.

D₅–CENH. This bit enables Enhanced Attributes for a CAPTION display (High = Disabled, Low = Enabled). The default is Low.

Note: OSD and XDS display modes always have Enhanced Attributes enabled.

D₆–ODRP. This bit selects the Drop Shadow or Full Box mode in the OSD and XDS displays (High = DROP SHADOW and Low = BOX). The default is High.

D₇–O15. This bit selects the number of TV lines per character row in the OSD and XDS display modes (High = 15 lines/row and Low = 13 lines/row). The default is High.

H Position Register Address = 02h

Bit	D ₇	D ₆	D ₅	D ₄	D ₃	D ₂	D ₁	D ₀
	BLUBX	HPO	h ₅	h ₄	h ₃	h ₂	h ₁	h ₀
	R/W	R/W	R/W	R/W	R/W	R/W	R/W	R/W

Figure 21. H Position Register (Address = 02h)

D₀–D₅–h₀–h₅. This bit is used to set the Horizontal Timing of the display. The default value in this register is 26h. Each count change represents an incremental timing change of 330 ns. Decreasing the value of this field moves the display to the RIGHT. Conversely, increasing the value of this field moves the display to the LEFT.

D₆–HPO. This bit sets the polarity to be used for locking to the HIN signal when in the EXT HLK mode (Low = Rising Edge, High = Falling Edge). The default is Low.

D₇–BLUBX. This bit designates the color of BOX (High = Blue Box and Low = Black Box). The default is Low.

Text Position Register Address = 03h

Bit	D ₇	D ₆	D ₅	D ₄	D ₃	D ₂	D ₁	D ₀
	y ₃	y ₂	y ₁	y ₀	x ₃	x ₂	x ₁	x ₀
	R/W	R/W	R/W	R/W	R/W	R/W	R/W	R/W

Figure 22. Text Position Register (Address = 03h)

D₀–D₃–x₀–x₃. This bit sets the Number Of Rows in the Text display. The default is 15 rows.

D₄–D₇–y₀–y₃. This bit sets the Base Row of the Text display.

The default value in this register is set to FFh, which produces a 15-row display with base row 15. Entering a new value in this register can alter the size and placement of the Text display. For example, to produce an 8-row Text display

with a base row of 12, this register should be set to C8h. If the value of the x and y bits result in a display where Text rows are off the top of the screen, then the first row of the Text display starts in row 1, having the number of rows determined by the x value.

Line 21 Activity Register Address = 04h

Bit	D ₇	D ₆	D ₅	D ₄	D ₃	D ₂	D ₁	D ₀
	res	res	res	res	res	res	XDS	SCH
							R	R

Figure 23. Line 21 Activity Register (Address = 04h)

D₀–SCH. This bit indicates data being processed in the Data Channel selected for display. The display becomes inactive if no data is received for the selected channel within the previous 16 seconds (High = Active, Low = Inactive). The reset state is Low.

D₁–XDS. This bit indicates that XDS data is being processed. The display becomes inactive if no XDS data is received within the previous 16 seconds (High = Active, Low = Inactive). The reset state is Low.

D₂–D₇. Reserved.

XDS Filter Register Address = 05h

Bit	D ₇	D ₆	D ₅	D ₄	D ₃	D ₂	D ₁	D ₀
	s ₂	s ₁	s ₀	PUBL	MISC	CHAN	FUTR	CURR
	R/W	R/W	R/W	R/W	R/W	R/W	R/W	R/W

Figure 24. XDS Filter Register (Address = 05h)

D₀–CURR. This bit selects the Current Class packets for output through the Serial Control port when XDS recovery has been enabled.

D₁–FUTR. This bit selects the Future Class packets for output through the Serial Control port when XDS recovery has been enabled.

D₂–CHAN. This bit selects the Channel Information Class packets for output through the Serial Control port when XDS recovery has been enabled.

D₃–MISC. This bit selects the Miscellaneous Class packets for output through the Serial Control port when XDS recovery has been enabled.

INTERNAL REGISTERS (Continued)

D₄-PUBL. This bit selects Public Service Class packets for output through the Serial Control port when XDS recovery has been enabled.

D₅-D₇-s₀-s₂. This bit selects a set of secondary parameters, tabulated below, to be used in filtering the XDS data when XDS recovery has been enabled.

Table 17. XDS Secondary Filter Settings¹

Secondary Filter	Filter Value (s0:s2)
All	0h
Time Information ²	1h
In Band Only	2h
Program Rating	3h
VCR Information ³	4h
Reserved	5h
Reserved	6h
Reserved	7h

Notes:

- Setting this register to 00h turns XDS data recovery off. Setting bits D₀ through D₄ enables XDS recovery for the classes selected, as qualified by the secondary filter (bits D₅-D₇). If bits D₀-D₄ are all set to "1", all classes of XDS data will be output, even the reserved and undefined classes.
- The Time Information includes the Time of Day (TOD) and Local Time Zone (LTZ) packets.
- The VCR Information selects TOD, LTZ, Net ID, Local Call Letters, Impulse Capture, Tape Delay, Composite 2, and Out-of-Band Channel Number packets for recovery.

Interrupt Request Register Address = 06h

Bit	D ₇	D ₆	D ₅	D ₄	D ₃	D ₂	D ₁	D ₀
	dTXT	dCAP	dXDS	dSCH	dLOK	EOF	DLE	res
	R/W	R/W	R/W	R/W	R/W	R	R	R

Figure 25. Interrupt Request Register (Address = 06h)

D₀-res. Reserved.

D₁-DLE. Active High, indicating that the data line has ended. This bit clears in each field a few lines after row 15.

D₂-EOF. Active High, indicating that the video signal is currently at the end of a field. This bit clears in each field a few lines after row 15.

D₃-dLOK. Active High, indicating that the state of the LOCK signal has changed. The SS register must be read to determine the current state.

D₄-dSCH. Active High, indicating that a change in selected channel activity has occurred. The Line 21 Activity register must be read in order to determine if the selected data channel is active.

D₅-dXDS. Active High, indicating that a change in XDS activity has occurred. The Line 21 Activity register must be read to determine if XDS data is active.

D₅-dXDS. Active High, indicating that a change in XDS activity has occurred. The Line 21 Activity register must be read to determine if XDS data is active.

D₆-dCAP. Active High, indicating that a change in a caption data channel activity has occurred. The Caption Activity Register (Address 08h) must be read to determine exactly which caption channels are now active.

D₇-dTXT. Active High, indicating that a change in a Text data channel activity has occurred. The Caption Activity Register (Address 08h) must be read to determine exactly which text channels are now active.

Note: Except as noted for the case of D₁ and D₂ above, the master device must write a 1 to the appropriate bit in the Interrupt Request Register to clear the Interrupt. Writing a 1 to any valid bit position, the Interrupt Request Register is equivalent to CLEARing an interrupt request on that bit.

Interrupt Mask Register Address = 07h

Bit	D ₇	D ₆	D ₅	D ₄	D ₃	D ₂	D ₁	D ₀
	dTXT	dCAP	dXDS	dSCH	dLOK	EOF	DLE	DAV
	R/W	R/W	R/W	R/W	R/W	R/W	R/W	R/W

Figure 26. Interrupt Mask Register Address = 07h

This register identifies which activities in the Interrupt Request Register are used to cause an interrupt. Setting a bit to a 1 enables the interrupt when the corresponding event becomes active. Setting all bits of this register to zero disables interrupts. The Caption Activity Register Address = 08h.

Caption Activity Register Address = 08h

Bit	D ₇	D ₆	D ₅	D ₄	D ₃	D ₂	D ₁	D ₀
	T4	T3	T2	T1	CC4	CC3	CC2	CC1
	R	R	R	R	R	R	R	R

Figure 27. Caption Activity Register (Address = 08h)

D₀–D₇—Activity Bits. These locations indicate the activity bits for the Line 21 data channels CC1–T4. Each bit is set High when a mode setting command for its data channel has been received on Line 21. The bit is cleared to the Low state if no activity is detected in that data channel during the next 12–16 seconds or if there is a loss of lock.

XDS Data Recovery

The Z86229 is able to recover Extended Data Services (XDS) information from the input video signal. This data, formatted according to EIA–608 specification, can contain a wide variety of information about current and future programs, the channel currently tuned, other channels, and miscellaneous data including time of day.

Note: XDS data is only present in the even field.

The Z86229 can recover XDS data even while performing its normal caption decoder or OSD functions.

XDS data packets are tagged according to a Class/Type system defined by the EIA–608 specification. The Z86229 can be programmed to filter the XDS data stream to extract only the classes of interest to the application. An additional level of filtering is provided that permits selection of certain groups of packets that are useful in specific applications. XDS filtering not only reduces the traffic on the serial bus, but it also reduces the load of the TV/VCR control processor, thereby simplifying external XDS decoding.

XDS data recovery is enabled by selecting one or more classes in the XDS Filter register. Optionally, a secondary filter code can be specified which further limits the packets to be recovered. When XDS recovery is enabled, filtered data pairs are loaded into the serial output registers of the Z86229 immediately upon receipt and in the order received. The DAV and RD2 bits of the Serial Status (SS) register then goes High, indicating the availability of two output

bytes. The external TV control processor is not required to send a READ SELECT command in order to read these data bytes.

When the XDS Filter register is set to 00h (the default state), XDS recovery is disabled.

Caution: When XDS data recovery is enabled, the external controller should never perform any other read operation, except for SS reads in the beginning of field 2. This situation is most easily accomplished by using the end of field (EOF) or data line end (DLE) interrupt to locate the end of field 2 or the vertical blanking interval (VBI) of field 1. From that point, the controller can perform the READ SELECT and READ functions during this portion of the video frame. Commands other than READ SELECTS do not interfere with XDS data recovery regardless of their position in the video frame.

Some examples of the WRITE commands used to set the XDS Filter Register in the Z86229 are indicated in Table 18. The XDS Filter Register bit assignments are defined in the Z86229 Internal Register section of this specification (see page 30 for details).

Table 18. XDS Data Extraction—
Example Filter Settings

{Write CMD, Filter Code}	XDS Filter Output
{C5,41}	All-In-Band, Current Class packets recovered.
{C5,61}	Program Rating, Current Class packets recovered. This filter may be used for Program Blocking data packet recovery.
{C5,1F}	All XDS packets recovered.
{C5,01}	All Current Class packets recovered.
{C5,28}	Time information recovered. This filter extracts the Time of Day (TOD) and Local Time Zone (LTZ) packets from the Miscellaneous Class data. This filter may be used to implement Auto Clock-Settings in TVs and VCRs
{C5,9F}	VCR Information recovered. Selects TOD, LTZ, Net ID, Local Call Letters, Impulse Capture, Tape Delay, Composite 2, and Out-of-Band Channel Number packets for recovery.

INTERNAL REGISTERS (Continued)

Filtered XDS Data Format

Filtered XDS data is output from the Z86229 in the order it is received on Line 21. The XDS filter function is essentially creating a new, smaller stream of XDS data packets. This new data stream looks exactly as though the Class and Type specified in the XDS Filter Register (05h) are the only data encoded on Line 21 of field 2. The filtered data output from the Z86229 is in full compliance with EIA-608 specifications for XDS data streams (headers and control codes intact). See the Note paragraph in the next column for a special exception to this rule.

XDS data and header information (including START, CONTINUE, and END commands) are passed through the filter for the XDS class and type specified in the XDS Filter Register. All other Line 21 data is filtered out. This data is neither output nor used to generate a data available flag (DAV) in the Serial Status Register.

To properly read filtered XDS data from the Z86229, the master device must first write the XDS Filter Register (05h) with its required XDS Class and Type information. For example in Z86229, in order to extract ONLY the Line 21 Program Rating information, the master must write the value 61h to the XDS Filter Register. The master should then poll the state of the DAV bit in the SSR until DAV = 1.

As soon as DAV=1, the master may initiate a 3-byte read in the normal manner (XDS data bytes always arrive in pairs, so it is safe to assume that RD2=1 when DAV=1 in the SSB). A 3-byte read always yields two data bytes, which in this case is the first two bytes of the Current Class, Program Rating Type XDS data stream encountered on Line21 field 2. The master device must then interpret those two

bytes according to the EIA-608 specifications for Current Class, Program Rating Type data. Refer to EIA-608 for data formats.

The XDS filters on the Z86229 greatly reduce the amount of field 2 data passed on to the master device for further processing and interpretation; however, the master device must still interpret the filtered data stream in accordance with EIA-608. The filtered data stream from the Z86229 is in full compliance with the EIA-608 specification. In other words, the filtered data stream contains all the XDS command and data packets, in standard EIA-608 format, but only for the selected XDS Class and Type(s).

Note: The Z86229 XDS filter for Program Rating information behaves differently than all other Z86229 predefined XDS filters. This change has been made to minimize the amount of data passed through the Program Rating XDS filter, thereby minimizing the interpretation and communications load on the master device. When the XDS Filter Register is set to 61h (Class=01h (Current), Type=05h (Program Rating) is the only data from the Line 21 field 2 that passes through the filter.

1. Program Rating Packet: [xxh,xxh]. The Current Class Program Rating data byte pair as defined in EIA-608. The program's rating is encoded per EIA-608 in the xxh byte pair.

2. The END Packet [0Fh,CHKSUM]. A two-byte packet that includes a CHKSUM computed per EIA-608. The checksum calculation includes the START packet [01h,05h], even though this value was not passed through the filter.

Z86229 COMMANDS AND REGISTER SUMMARY

Table 19. Z86229 Summary of Control Commands

Command Name	Command Code	Function
RESET	FBh, FCh, 00h	RESET is a three-byte command sequence in SPI or I ² C mode. The RESET command establishes all the specified default settings in the device, but it does not reset the serial port itself. This sequence can be entered without RDY being set.
NOP	00h	NOP is a one-byte command for use in SPI or I ² C mode. The NOP command does not affect the status of the RDY bit in the Serial Status (SS) register and can be executed independent of the RDY status.
SSB	FFh, ...Fh, FEh	Serial Sync Bytes (SSBs) are used in SPI mode only. This command actually consists of a string of single-byte commands in the form FFh, ..., FFh, FEh. SPI mode communications can be synchronized by sending a synchronizing data string to the part. This string should consist of at least two SSB bytes of FFh followed by one SSB byte of FEh. At the end of the FEh byte, the port is ready for use.
CPTX	10h–1Fh	CPTX selects a Closed Caption (CC1–CC4) or Text (T1–T4) data channel for processing or display.
DISP	20h–28h	DISP selects a preprogrammed XDS screen template for display, with or without a 16-Second Erase timer enabled.
RDS1	40h–47h	RDS1 is a one-byte command used to initiate a one-byte read sequence by moving the contents of the register identified by the address field (AD00:02) of the command to the output register. Addresses 0h–7h are valid in the RDS1 command field AD00:02.
RDS2	60h–66h	RDS2 is a one-byte command which is used to initiate a two-byte read sequence by moving the contents of the two consecutive registers, starting with the one identified by the address portion of the command (AD00:AD02), to the output registers and setting the RD2 bit in the SS register. Only Addresses 0h–6h are valid in the RDS2 command field AD00:02.
READ1	F8h	A command to read one byte in the SPI mode.
READ2	F9h	A command to read two bytes in the SPI mode.
WRxx	C0h–DFh, XXh	The WRITE commands require two bytes to execute. The first byte is the write command and includes the Z86229 register address (AD00:04) being written. The second byte (XXh) is the data to be written.

INTERNAL REGISTERS (Continued)

Table 20. Z86229 OSD Display Mode Commands

Command Name	Command Code	Function
RETURN	30h	Carriage return for OSD when in TEXTSET mode
CLRE	31h	OSD equivalent of delete to end of row(DER)
TEXTSET	32h	Establishes a Text type of OSD display
POPSET	33h	Establishes a pop-on type of OSD display
FLIP	36h	OSD equivalent of pop-on caption, end of caption(EOC)
OEDM	37h	OSD equivalent of erase displayed memory
OENM	38h	OSD equivalent of erase non-displayed memory
POP ROW SEL (with Double-High Option)	A0h,rrh	This command sets the display row and moves the cursor to char column 1. The low order nibble of rr designates the display row. Bit 5 of rr specifies a Double-High row. For example, rr = 0Eh would select display row 14; rr = 23h would select display row three, Double-High.
PHYS ROW SEL	A1h,rrh	This command sets the physical row, where the low order nibble of rr designates the physical row rr value from 00h to Fh.
CURSOR SET	A2h,cch	This command places the cursor at the character column position designated by cc, which can be any value from 00h to 20h (column 0–32). Zero is the PAC space.
WRITE CHAR	A3h,ddh	This command writes the data byte dd to the current cursor location and then increments the cursor.
WRITE MAP	A4h,rrh	This command maps the current physical row to the display row designated by the low nibble of the rr byte. Bit 4 of rr = 1 enables display of the row. Bit 5 of rr = 1 indicates a Double-High row.
WRITE CHAR DBL WIDE	A5,ddh	This command is the same as the A3 command, but specifies a Double-Wide character.
WAIT	A6h,nnh	This command sets the RDY bit of SS, thereby suspending the serial command execution for approximately the number of frames designated by the nn byte.
GRAPHICS	84h,30h	This command sets the Graphics Character set in force.
EXTENDED	8Ch,30h	This command sets the Extended Character set in force.

Table 21. Summary of Z86229 Internal Registers

Register Name	Address	D ₇	D ₆	D ₅	D ₄	D ₃	D ₂	D ₁	D ₀
Serial Status Register (SSR)	None	RDY	DAV	RD2	WOVR	INTR	ROVR	FLD	LOCK
Configuration	00h	res	res	res	res	VLK	HLK	MONO	TVS
Display	01h	O15	ODRP	CENH	C15	CDRP	TENH	T15	TDRP
H Position	02h	BLUBX	HPO	h ₅	h ₄	h ₃	h ₂	h ₁	h ₀
Text Position	03h	y ₃	y ₂	y ₁	y ₀	x ₃	x ₂	x ₁	x ₀
Line 21 Activity	04h	res	res	res	res	res	res	XDS	SCH
XDS Filter	05h	s ₂	s ₁	s ₀	PUBL	MISC	CHAN	FUTR	CURR
Interrupt Request	06h	dTXT	dCAP	dXDS	dSCH	dLOK	EOF	DLE	res
Interrupt Mask	07h	dTXT	dCAP	dXDS	dSCH	dLOK	EOF	DLE	DAV
Caption Activity	08h	T4	T3	T2	T1	CC4	CC3	CC2	CC1

ON-SCREEN DISPLAY

OSD Operation

The Z86229 has a fully programmable, general purpose On-Screen Display (OSD) built in. The user can supply information for display through the serial port. In addition to all the normal and extended features of the VBI data display modes, the OSD mode also has available added graphics characters, Double-High and Double-Wide characters, and the ability to position the display anywhere on the screen with an adjustable (vertical) box size. The Double-High and Double-Wide characters are especially useful for creating OSD screens for display inside a Picture-in-Picture (PiP) window. The OSD display mode can use either 13 or 15 lines per row, with a box or drop shadow. The default is 15 scan lines per row in addition to the drop shadow. Enhanced attributes are always enabled.

The 15 scan line per row display can only show 13 rows on-screen when in the NTSC mode. Rows 14 and 15 is off-screen and should not be addressed. In the PAL mode all rows are visible.

The 15 scan lines per row mode display can show the full graphic characters and accented capital letters and descenders without the potential overlap that would result from the 13 scan line per row display. If the OSD display mode is changed to a 13 scan line per row mode, the top two scan lines of any graphics or accented capital letter is "ORed" together with the bottom two scan lines from the row above. In 13 line-drop-shadow mode, it also results in a side shadow effect. Graphics characters should not be used in the 13-line drop-shadow mode.

OSD Character Set

There are 256 possible addresses in the OSD character set. Figure 28 illustrates the address map in the range 00h–BFh. This portion of the addressable space contains the control bytes and regular character set. The address map in the range C0h–FFh is illustrated in Figure 17.

These addresses are shared by the Extended Character set and the Graphics Character set. Any particular OSD screen can use one or the other of these sets of characters but not both.

The character set in force is controlled by the type of display mode being invoked. When the Drop Shadow is being used,

by default, the Graphics Character set is displayed in response to an address in the C0h–FFh range; however, if a BOX display is used, the Extended Character set is invoked. In either case the user can switch to the other set by means of the appropriate command (GRAPHICS or EXTENDED).

The $V_{IN}/INTRO$ pin serves as the input for a Vertical Pulse from the TV receiver when V Lock = V_{IN} mode is enabled. This condition permits an OSD display even when no video input is present. If this mode is not required, the default state V Lock = VIDEO should be active. This pin then carries the INTRO output signal.

OSD Commands

OSD commands are one- and two-byte commands. They are used to control the loading of data for OSD display and their presentation to the screen. Normally, the OSD display mode uses 15 TV lines per display row to enhance the OSD presentation.

The two-byte commands enable direct access to any location on the display screen. The user can customize displays by using these commands. Each command byte pair consists of an instruction byte followed by a data byte. (See A Sample OSD Program on page 39.)

Note: In this product specification, one- and two-byte commands are written as one or two two-digit Hex values, separated by a comma, within curly braces. For example, the WRITE CHAR command for entering the letter A as a single-width character would be shown in this document as {A3,41}. This command would write the letter A to the current cursor position of the display row being addressed. Refer to the Serial Communications Interface and Commands sections for further details of the serial communications and the OSD commands (see pages 22 and 26, respectively).

The one-byte commands provide a simple means of creating OSD displays using preset screen formats built into the part. These built-in modes provide the user with a simple way to generate OSD screens. Two preset display modes are available called POPSET and TEXTSET.

ON-SCREEN DISPLAY (Continued)

Second Nibble	0	1	2	3	4	5	6	7	8	9	A	B	C	D	E	F	
First Nibble	0	White Char	White Underline Char	Green Char	Green Underline Char	Blue Char	Blue Underline Char	Cyan Char	Cyan Underline Char	Red Char	Red Underline Char	Yellow Char	Yellow Underline Char	Magenta Char	Magenta Underline Char	Italic Char	Italic Underline Char
1	®	°	½	¿	™	¢	£	♫	à	¡	è	â	ê	î	ô	û	
2	Opaque Space	!	"	#	\$	%	&	'	()	á	+	,	-	.	/	
3	0	1	2	3	4	5	6	7	8	9	:	;	<	=	>	?	
4	@	A	B	C	D	E	F	G	H	I	J	K	L	M	N	O	
5	P	Q	R	S	T	U	V	W	X	Y	Z	[é]	í	ó	
6	ú	a	b	c	d	e	f	g	h	i	j	k	l	m	n	o	
7	p	q	r	s	t	u	v	w	x	y	z	ç	÷	Ñ	ñ	■	
8	‘	’	@	SH	.	“	”	ß	¥	¤	ø	ç	”	°	«	»	
9	White Opaque Background	White Semitrans Background	Green Opaque Background	Green Semitrans Background	Blue Opaque Background	Blue Semitrans Background	Cyan Opaque Background	Cyan Semitrans Background	Red Opaque Background	Red Semitrans Background	Yellow Opaque Background	Yellow Semitrans Background	Magenta Opaque Background	Magenta Semitrans Background	Black Opaque Background	Black Semitrans Background	
A		—	—		┌	┐		└	┘		┌	┐		└	┘		
B	*	{	}	\	^	_		~	Transparent Space	Flash	Double Wide	Transparent Background	Transparent White Foreground	Transparent White Underline Foreground	Black Foreground	Black Underline Foreground	

Figure 28. OSD Character Set

Using POPSET

POPSET provides an OSD mode that operates in a fashion similar to the Caption Pop-on mode. The POPSET command organizes the memory into two eight row blocks, one visible on-screen and the other off-screen. An OSD screen can then be created by loading the off-screen memory by the command sequence POP ROW SEL, WRITE CHAR .. WRITE CHAR .. POP ROW SEL .. WRITE CHAR .. WRITE CHAR. The data can then be presented for on-screen display with the FLIP command.

The following is an example of a command sequence that creates an OSD screen using the POPSET mode. It creates

A Sample OSD Program

OSD Commands	Function
{33}	Select POPSET mode. The first block of commands display VIDEO in Double-Wide chars. Each character is entered with the WRITE CHARD command.
{A0,02}	Select POPROW 2, cursor at character column 1
{A2,00}	Move cursor to 0
{A3,08}	PAC for RED chars written in PAC location.
{A5,3e}	Double-Wide char ">" displays in char col 1 & 2
{A3,02}	Green mid code written to char col 3
{A5,56}	'V' written to char col 4 & 5.
{A5,49}	'I'
{A5,44}	'D'
{A5,45}	'E'
{A5,4F}	'O'
The next block of commands displays AUDIO in row 4 with Double-Width.	
{A0,04}	Select POPROW 4, cursor in char col 1
{A2,03}	Cursor to char col 3
{A3,02}	Green mid code written to char col 3
{A5,41}	'A' written to char col 4 & 5.
{A5,55}	'U'
{A5,44}	'D'
{A5,49}	'I'
{A5,4F}	'O'
The next set of commands displays the word "TIME" in row 6 with Double-Wide characters. Spacing is obtained without the A2 Cursor Set command to illustrate an alternate means of column alignment.	
{A0,06}	Select POPROW 6, cursor in char col 1

a typical menu screen used in television receivers. It should be noted that in this document, commands are written as either a one- or two-byte HEX value, separated by a comma, within curly braces (that is, a sample two-byte OSD command: {A1,00}).

In the sample programs below, a comment field can be written following the command to describe the action of the command or sequence of commands, where appropriate. The comment field is identified by an asterisk (*), and any text following the * is taken as a "comment". Therefore, to include a comment in the program, simply add the * at the beginning of the function description.

OSD Commands	Function
{A3,02}	Green mid code written to character col 1
{A5,20}	Double-Wide space char written to character columns 2 & 3
{A5,54}	'T' written to char col 4 & 5.
{A5,49}	'I'
{A5,4d}	'M'
{A5,45}	'E'
{A0,06}	Select POPROW 6, cursor in char col 1 SET UP is displayed in row 8 using Double-Wide chars.
{A0,08}	Select POPROW 8
{A2,03}	Cursor to 3
{A3,02}	Green characters
{A5,53}	'S'
{A5,45}	'E'
{A5,54}	'T'
{A5,20}	' '
{A5,55}	'U'
{A5,50}	'P'
CLOSED CAPTION displayed in row 10 using Double-Wide characters. The last letter, N, appears in character column 30 and 31.	
{A0,0A}	Select POPROW a
{A2,03}	Cursor to 3
{A3,02}	Green char
{A5,43}	'C'
{A5,4C}	'L'
{A5,4F}	'O'
{A5,53}	'S'
{A5,45}	'E'
{A5,44}	'D'
{A5,20}	' '
{A5,43}	'C'

ON-SCREEN DISPLAY (Continued)

OSD	
Commands	Function
{A5,41}	'A'
{A5,50}	'P'
{A5,54}	'T'
{A5,49}	'I'
{A5,4F}	'O'
{A5,4E}	'N'

The line, Select: ENTER EXIT: MENU, appears in row 12, starting in character column 2. These are displayed as single-wide characters.

{A0,0C}	select POPROW c
{A3,06}	CYAN char
{A3,53}	'S'
{A3,65}	'e'
{A3,6C}	'I'
{A3,65}	'e'
{A3,63}	'c'
{A3,74}	't'
{A3,3A}	':'
{A3,20}	''
{A3,45}	'E'
{A3,4E}	'N'
{A3,54}	'T'
{A3,45}	'E'
{A3,52}	'R'
{A3,20}	''
{A3,20}	''
{A3,45}	'E'
{A3,78}	'x'
{A3,69}	'i'
{A3,74}	't'
{A3,3A}	':'
{A3,20}	''
{A3,4D}	'M'
{A3,45}	'E'
{A3,4E}	'N'
{A3,55}	'U'
{36}	FLIP command flips memories, popping the full menu on-screen.

Using Textset

TEXTSET features an OSD mode that paints on the screen in a manner similar to a Text Mode display. The memory is organized using the current information in the Text Position register, and the display follows the current setting

in the Display register. The default display parameters for the OSD are 15 lines per row, Drop-Shadow mode. The TEXTSET command can be followed by successive WRITE CHAR commands interspersed with the RETURN command at the appropriate points to paint on an OSD display starting at the top of the Text window. These commands are set by the Text Position register, moving to the next line at each RETURN command. The display scrolls if a RETURN command is sent when at the bottom of the Text window. A subsequent TEXTSET command clears the screen, thereby generating a new OSD screen.

The following example shows an OSD display generated using TEXTSET. This screen is a paint-on rather than pop-on. Features like flash are included in the command sequence for demonstration purposes.

The Text display is first set to 4 rows at the bottom of the screen.

OSD	
Commands	Function
{C3,D4}	Set Textpos reg for base row 13, 4 rows
{C1,80}	Set OSD display for BOX mode, 15 lines/row
{C2,A6}	Set BOX to Blue, keep HPOS unchanged
{32}	Select TEXTSET mode
The next two commands are used for positioning and color.	
{A2,05}	Cursor to char pos 5
{A3,08}	Mid code to make Red chars. Cursor moves to 6
{A3,B9}	Mid code to start Flash, Cursor moves to 7
{A5,57}	'W' Double-Wide, char col 7,8
{A5,41}	'A' Double-Wide, char col 9,10
{A5,52}	'R' Double-Wide, char col 11,12
{A5,4E}	'N' Double-Wide, char col 13,14
{A5,49}	'I' Double-Wide, char col 15,16
{A5,4E}	'N' Double-Wide, char col 17,18
{A5,47}	'G' Double-Wide, char col 19,20
{A5,20}	'' Double-Wide, char col 21,22
{30}	Return moves cursor to next row, char pos 1
{A2,00}	Cursor to char pos 0
{A3,0A}	PAC sets color to Yellow, cursor moves to char pos 1
{A3,54}	'T' single-width, cursor moves to char pos 2
{A3,68}	'h'
{A3,65}	'e'

OSD Commands	Function
{A3,72}	'r'
{A3,65}	'e'
{A3,20}	' '
{A3,69}	'i'
{A3,73}	's'
{A3,20}	' '
{A3,61}	'a'
{A3,20}	' '
{A3,74}	't'
{A3,6F}	'o'
{A3,72}	'r'
{A3,6E}	'n'
{A3,61}	'a'
{A3,64}	'd'
{A3,6F}	'o'
{A3,20}	' '
{A3,69}	'i'
{A3,6E}	'n'
{A3,20}	' '
{A3,74}	't'
{A3,68}	'h'
{A3,65}	'e'
{A3,20}	' '
{A3,61}	'a'
{A3,72}	'r'
{A3,65}	'e'
{A3,61}	'a'
{A3,2E}	'.'
{30}	Return moves cursor to next row, char pos 1
{A3,50}	'P'
{A3,6C}	'l'
{A3,65}	'e'
{A3,61}	'a'
{A3,73}	's'
{A3,65}	'e'
{A3,20}	' '
{A3,74}	't'
{A3,61}	'a'
{A3,6B}	'k'
{A3,65}	'e'
{A3,20}	' '
{A3,61}	'a'
{A3,6C}	'l'
{A3,6C}	'l'
{A3,20}	' '

OSD Commands	Function
{A3,6E}	'n'
{A3,65}	'e'
{A3,63}	'c'
{A3,65}	'e'
{A3,73}	's'
{A3,73}	's'
{A3,61}	'a'
{A3,72}	'r'
{A3,79}	'y'
{30}	
{A3,70}	'p'
{A3,72}	'r'
{A3,65}	'e'
{A3,63}	'c'
{A3,61}	'a'
{A3,75}	'u'
{A3,74}	't'
{A3,69}	'i'
{A3,6F}	'o'
{A3,6E}	'n'
{A3,73}	's'
{A3,20}	' '
{A3,69}	'i'
{A3,6D}	'm'
{A3,6D}	'm'
{A3,65}	'e'
{A3,64}	'd'
{A3,69}	'i'
{A3,61}	'a'
{A3,74}	't'
{A3,65}	'e'
{A3,6C}	'l'
{A3,79}	'y'
{A3,2E}	'.'
At this point all 4 rows are on-screen. The following wait command holds the display for a period = (12x16)/30 seconds.	
{A6,2E}	Wait for 6.4 seconds
Create a smooth scroll to clear the screen with the following 4-row sequence.	
{30}	Return, first row.
{A6,0F}	wait 15 frames
{30}	Return second row.
{A6,0F}	
{30}	Return third row.
{A6,0F}	
{30}	Return fourth row.

ON-SCREEN DISPLAY (Continued)

OSD	
Commands	Function
{A6,0F}	Create a new screen display.
{A3,74}	't'
{A3,68}	'h'
{A3,69}	'i'
{A3,73}	's'
{A3,20}	' '
{A3,77}	'w'
{A3,61}	'a'
{A3,73}	's'
{A3,20}	' '
{A3,6F}	'o'
{A3,6E}	'n'
{A3,6C}	'l'
{A3,79}	'y'
{A3,20}	' '
{A3,61}	'a'
{A3,20}	' '
{A3,74}	't'
{A3,65}	'e'
{A3,73}	's'
{A3,74}	't'
{30}	Return
{A3,64}	'd'
{A3,6F}	'o'
{A3,6E}	'n'
{A3,27}	'' '
{A3,74}	't'
{A3,20}	' '
{A3,70}	'p'
{A3,61}	'a'
{A3,6E}	'n'
{A3,69}	'i'
{A3,63}	'c'
{A3,2E}	'.'

Using the WAIT Command

The WAIT command suspends serial port communications for a period of time. The TEXTSET example above used the WAIT command in two ways: first, to hold a display on-screen for a period of time before taking a second action, and second, it was used to create a smooth scroll by timing the wait to the scroll rate.

The WAIT command can also be used to control the appearance of two OSD displays in sequence without tying up the master device for the total display time. In the following example, the POPSET mode is used to pop on two sequential menu screens with a built-in pause between the two displays. In this case, the WAIT is placed just before the most recent FLIP command. This condition allows the entire command sequence to be sent to the Z86229 at one time. Because the RDY bit is set by the WAIT command, this condition also allows the FLIP to be input as well.

The command sequence would be as follows:

OSD	
Commands	Function
{33}	Select pop mode
{..}	Screen generation commands for first display
{..}	
{..}	
{36}	FLIP command. Flips memories, popping the first menu on-screen.
{38}	OENM, to ensure non-displayed memory is erased.
{..}	Screen generation commands for second display
{..}	
{..}	
{A6,C0}	Wait 6 seconds
{36}	FLIP command flips memories, popping the second menu on-screen.

Using The Graphics Character Set

The following example creates an OSD screen which illustrates several features of the Z86229 including the use of the Graphics character set to generate a large font word. The particular features shown are purely for demonstration purposes and are not intended to suggest a particular application.

For the sake of brevity, the "text" to be displayed is shown as a string within quotes rather than as the actual command sequences required. Single quotes (' ') signifies standard characters, while double quotes ("") signifies Double-Wide characters.

{33}	Select pop mode
{A0,02}	Select POPROW 2
{A2,00}	Move cursor to 0

{33}	Select pop mode
{A3,03}	PAC, GREEN chars
'THIS IS A DEMONSTRATION OF OSD'	
{A0,03}	Select POPROW 3
{A2,00}	Cursor to 0
{A3,08}	PAC, RED char
'The Z86229 has many features'	
{A0,04}	Select POPROW 4
{A2,00}	Cursor to 0
{A3,04}	Blue char
'besides displaying Captions.'	
{A0,06}	Select POPROW 6
{A2,00}	Move cursor to 0
{A3,07}	PAC, Cyan Underlined
'Color and Underline may be used'	
{A0,08}	Select POPROW 8
{A2,00}	Move cursor to 0
{A3,0a}	PAC, Yellow chars
'Double-Wide'	
{A0,09}	Select POPROW 9
{A2,00}	Move cursor to 0
{A3,0c}	PAC, Magenta chars
'Graphics can be created like'	
The next group of commands use Graphic Char patterns to make the two row word HELLO. The data byte of the WRITE CHAR command is the address location for the graphic cell required as illustrated in Figure 5.	
{A0,0b}	Select POPROW 11
{A2,00}	Move cursor to 0
{A3,06}	PAC, Cyan chars
{84,30}	Set Graphics mode in case another user had changed it earlier.
{A5,20}	' '
{A5,20}	' '
{A5,20}	' '
{A5,20}	' '
{A3,20}	' '
{A3,eb}	Graphic Cell
{A3,ea}	Graphic Cell
{A3,20}	' '
{A3,fb}	Graphic Cell
{A3,20}	' '
{A3,ea}	Graphic Cell
{A3,20}	' '
{A3,ea}	Graphic Cell
{A3,20}	' '
{A3,fa}	Graphic Cell
{A3,f5}	Graphic Cell

{33}	Select pop mode
{A0,0c}	Select POPROW 12
{A2,00}	Move cursor to 0
{A3,06}	PAC, Cyan chars
{A5,20}	' '
{A5,20}	' '
{A5,20}	' '
{A5,20}	' '
{A3,20}	' '
{A3,ea}	Graphic Cell
{A3,ea}	Graphic Cell
{A3,20}	' '
{A3,eb}	Graphic Cell
{A3,20}	' '
{A3,eb}	Graphic Cell
{A3,20}	' '
{A3,eb}	Graphic Cell
{A3,20}	' '
{A3,eb}	Graphic Cell
{A3,d7}	Graphic Cell
{36}	flip

Manual Row Mapping and Control

For most OSD displays, the POPSET, POP ROW SEL, FLIP, TEXTSET, and RETURN commands should be used to control row positioning.

TEXTSET mode provides automatic row allocation from the top to bottom of a screen with all rows continuously visible. Additionally, TEXTSET screens have a definable vertical window size and position, allowing support of automatic text scrolling at the bottom of the window.

POPSET screens are created in off-screen memory while the previous screen is displaying. Up to 8 rows of characters can be defined. These rows can be mapped to any of 15 display rows using the POP ROW SEL command. Double-high rows may also be defined with POP ROW SEL. The FLIP command is then used to “pop-on” up to 8 rows of characters replacing the previous screen. The off-screen rows may be mapped to the same row numbers as the on-screen rows.

In some applications, it may be necessary to access the display hardware at a lower level to achieve special screen effects. Examples of these special situations include the following:

1. More than 8 on-screen rows required in a “pop-on” style screen.

ON-SCREEN DISPLAY (Continued)

2. Characters must be added dynamically to an on-screen display.
3. On-screen rows must be dynamically moved, disabled, or enabled.

The Z86229 supports manual screen mapping and display control commands to handle these special applications. These commands allow each of the 16 physical rows of character memory implemented in the device to be mapped to any of 15 display row positions.

Additionally, the 16 physical rows can be set for single or double height and independently enabled and disabled. Manual row mapping and control commands should only be used in the POPSET OSD mode.

The procedure for manual row control is as follows:

1. Use the POPSET command to select the OSD pop-up mode. This command prepares the Z86229 for OSD input, clears the row maps, and erases character memory.
2. Select a physical row (0 through 15) using the PHY ROW SEL command.
3. Use the WRITE MAP command to set the display row (1 through 15), Double-High bit, and enable bit of the selected physical row.

The CURSOR SET, WRITE CHAR and WRITE CHARD commands are used to position the cursor and write the characters in the selected physical row.

A physical row may be re-selected at any time to change its characters, row maps, Double-High mode, or enable status. For example, it may be desirable to load several rows of characters into physical memory without enabling them. All of the rows could then be made to “pop” onto the screen simultaneously by setting their enable bits.

The following example uses manual row mapping and control to write three rows of characters. The first row is a Double-High row that is enabled before the characters are sent. This condition allows the characters to “paint” onto the screen as they are received. The second and third row are not initially mapped or enabled when the characters are written. They are then mapped and enabled after a two second pause. A new row is then created off-screen to replace the third row. Finally, after a 2 second pause, the second row

is moved to a new display row, the original third row is disabled, and the new third row is mapped and enabled.

OSD Cmds	Function
{33}	Select POPSET mode
{A1,00}	Select physical row 0
{A4,31}	Map it to display row 1, enable, double
{A2,02}	Cursor to 1
{A3,02}	Green
	Double-Wide text
	'The First Row'
{A1,01}	Select physical row 1
{A2,00}	Cursor to 0
{A3,0a}	Yellow
	Single wide text
	'These two rows are'
{A1,07}	Select prow 7
{A2,00}	Cursor to 0
{A3,06}	Cyan
	'Single wide text enabled after a pause'
{A6,40}	Wait 2 seconds
	Do the map and enable
{A1,01}	Select physical row 1
{A4,16}	Map it to display row 6, enable
{A1,07}	Select prow 7
{A4,17}	Map it to draw 7, enable
	Prepare a new row to replace row 7
{A1,08}	Select physical row 8
{A2,00}	Cursor to 0
{A3,06}	Cyan
	Single wide text
	'Moved after a pause'
{A6,40}	Wait 2 seconds
	Make the modified display
{A1,01}	Select physical row 1
{A4,1A}	Map it to display row 10, enable, double
{A1,07}	Select prow 7
{A4,00}	Disable it
{A1,08}	Select prow 8
{A4,1B}	Map it to row 11,enable, double

DEMONSTRATION PROGRAMS

Communicating with the Z86229

Communications with the Z86229 is accomplished using its serial communications interface. Through hardware setup, this interface can be configured into either of two serial protocols, I²C or SPI. The details of hardware setup have been provided in the Serial Communications Interface section (page 22) and are not dealt with here. It is assumed that the user is familiar with the serial protocol requirements.

Note: In the following descriptions <ENTER> means press the Enter key.

I²C Operation

The Z86229 is configurable as an I²C slave device. The PC communicates with the Z86229 through its parallel port. These programs are not intended as examples of how to program the application, but are only provided as a means of illustrating the serial control process and the capability of the Z86229.

The three programs available are titled IICO, SCRIPTI, and XDSCAP. These programs have been compiled and run satisfactorily with the Z86229 in a test board. Compiled versions are available on disk. Contact your local ZiLOG sales office for further information on these programs.

IICO Program

This program sends one byte to the Z86229 without checking the status of the READY bit. The program returns the contents of the Serial Status (SS) Register after the command has been entered. When the program is active the screen displays:

```
IIC Command Byte >
```

The user may enter any valid one-byte command such as FBh (Reset) or 00h (NOP) and then hit the ENTER key. The screen then displays the byte entered and the SS register contents read:

```
IIC Byte = 00
```

```
IIC Status = 83h
```

The text above shows that the NOP command was entered. The SS register contents, 83h, indicates that the RDY, FLD,

and LOCK bits are High. This condition indicates that the serial port is ready for further input, that the input video signal was in Field 1 at the time the status was read, and that the part is operating in video-lock mode.

The IICO program is exited by entering a Control+C (^C) character.

For example, entering the following single byte commands would generate the following:

Command	Command Code
Reset the part	FB, FC, 00
Set the part to CC1 display mode, decoder ON.	17h
Change to the XDS Graze display mode, 16-Second Timer ON.	23h
Return to the CC1 display mode, decoder ON.	17h

The commands that control most of the display capability of the Z86229 are all one-byte commands which can be entered using the IICO program. These commands are tabulated below for convenience.

General Commands

Serial Command	Command Code
RESET	FBh, FCh, 00h
NOP	00h
SSB	FFh,...FFh,FEh

Caption/Text Display Mode Commands

CPTX Command	CPTX Command Code	
	Decoder ON	Decoder OFF
CC1	17h	16h
CC2	15h	14h
CC3	1Fh	1Eh
CC4	1Dh	1Ch
T1	13h	12h
T2	11h	10h
T3	1Bh	1A
T4	19h	18

DEMONSTRATION PROGRAMS (Continued)

XDS & Miscellaneous Display Mode

Commands

XDS Command		
CMD Byte	XDS Disp	16 Sec Timer*
23h	XDSG	ON
27h	XDSG	OFF
21h	XDSF	ON
25h	XDSF	OFF
20h	Note	ON
24h	Note	OFF

Note: *Changing the ON/OFF state of the 16-Second Erase Timer has no affect on the current display mode in operation.

SCRIPTI Program

This program is designed to send any number of one or two-byte commands to the Z86229. The list of commands to be executed are contained in Script files that have the extension .SER. Examples of such files are presented in the following paragraphs. SCRIPTI can be used to control the display modes in the same manner as the IICO program, except that the one-byte command to be sent must be in a Script file. For example, a file called CC1.SER would contain the one-byte command:

```
{17}* send CC1, decoder ON
```

The program is invoked by typing:

```
SI File_name<ENTER>
```

Note: Enter the file_name without the .SER extension.

The screen displays:

```
EEG CCD2 Serial Interface Script Player  
Version x.xx
```

```
Slave Address is 28h
```

```
Script File Done
```

The responding slave address is reported to the screen. When all the commands in the file have been successfully sent to the Z86229, the PC returns to the system prompt.

The program checks the RDY status before sending each byte. If, during the entry of a command, the RDY bit is not found to be a "one" after an extended wait, the program reports the contents of the SS register and then continue checking for RDY Script Files.

Script Files

Script files can be generated to perform all of the setup and control functions required to use the part in an application. The script files that follow are examples of such files used to setup the Z86229 for different operating conditions. Some of the files contain only a single command, while others include several commands. The user should refer to the Command and Registers section for details. Although the following examples are organized according to a particular register, some of the files contain information for several registers.

Configuration Register Script Files

File Name	Command	Function
FIGM	{C0,02}	Set config to mono
FIGVH	{C7,00}	Set INT Mask register clear
	{C0,0C}	Set config to ext VLK & HLK
	{83,12}	Bit set ext V pulse for pos
	{C2,1D}	Center h display
FIGN	{C0,00}	Set config back to default state
	{C2,26}	Return h display to center
FIGPAL	{C1,D2}	Change display register to C15 & T15
	{C3,FF}	Change text pos register to base row 15, 15 rows
	{C0,01}	Set config register to TVS = 1 Changes VBI line to L22 PAL

Display Register Script Files

File Name	Command	Function
DN	{C1,C0}	Set display register to default conditions
DT1	{C1,C1}	Set display register to Text drop shadow
DT2	{C1,C2}	Set display register to Text 15 lines per row
DT3	{C1,C3}	Set display register to Text drop shadow, 15 lines
DT3A	{C1,C3}	15 tv lines and drop text
	{C3,DD}	13 rows of text, base row 13
DCE	{C1,e0}	Disable CAP Enhanced mode

H Position Register Script Files

File Name	Command	Function
HPOSC	{C2,26}	Center box
HPOSR	{C2,1D}	Move box right 2.97 μ s (from center)
HPOSL	{C2,29}	move box left 0.99 μ s (from center)
HPOSCB	{C2,a6}	center box & make Box Blue

Text Position Register Script Files

File Name	Command	Function
TPOS15	{C3,FF}	Text, base row 15, 15 rows
TPOS13	{C3,FD}	Text, base row 15, 13 rows
TPOS10	{C3,FA}	Text, base row 15, 10 rows
TPOS10A	{C3,BA}	Text, base row 11, 10 rows

XDSCAP Program

This program performs the application's task of XDS data recovery. XDS recovery must first have been enabled through the appropriate XDS Filter command. Script file examples for setting the XDS Filter are shown below.

The program is invoked by typing:

```
xdscap<ENTER>
```

When the program is invoked the PC screen shows:

```
EEG CCD2 XDS Data Recovery Test Program
Version x.xx
```

```
Slave Address is 28h
```

The responding slave address is reported to the screen.

After communication is acknowledged, the program displays all XDS data recovered from those packets that were enabled through the XDS Filter command:

```
{01,03}Current Program{00}{0F,7F}...etc
```

The ASCII characters are shown as ASCII characters while the non-printing characters are displayed by their Hex value within curly braces. Byte pairs, such as Class,Type, are shown as pairs within the curly braces, separated by a comma (that is, {01,03}).

If no data is received within approximately 45 seconds, the program times out, reports "Data Not Available", and exits.

Note: The XDSCAP program can also be exited by entering a Control C (^C) character.

XDS Filter Register Script Files

File Name	Command	Function
FILA	{C5,1F}	Set XDS filter to all
FILO	{C5,00}	Set XDS filter to none. Turns off XDS recovery
FILCA	{C5,01}	Set XDS filter to all current class
FILC	{C5,41}	Set XDS filter to current, in band class
FILFA	{C5,02}	Set XDS filter to all future class
FILCH	{C5,04}	Set XDS filter to channel class
FILM	{C5,08}	Set XDS filter for misc. info
FILTIME	{C5,28}	Set XDS filter time only
FILVCR	{C5,9E}	Set XDS filter vcr info

Using Interrupts

Interrupts involve the use of the Line 21 Activity Register, the Interrupt Request Register, and the Interrupt Mask Register. The Z86229 must be configured for VLK internal so that the V_{IN} signal (Pin 13) is an output providing the interrupt output signal.

The interrupt status can be polled through bit D_3 of the Serial Status (SS) Register if the interrupt signal cannot be used.

Interrupts are disabled when the Interrupt Mask Register has been set to all zeros. Conversely, interrupts are enabled by setting one or more of the active bits to a "1". When enabled, the INTRO signal becomes a "1" when the enabled mask event(s) becomes active. If more than one event has been activated, the Interrupt Request Register must be queried to determine which event has occurred. The DLE and EOF interrupts are cleared at the end of the field in which they occurred.

Interrupt Mask Register Script Files

File Name	Command	Function
INTRD	{C7,02}	Set DLE active
INTRLK	{C7,08}	Set dLOK active
INTRX	{C7,20}	Set dXDS active
INTRC	{C7,12}	Set DLE & dC/T active

DEMONSTRATION PROGRAMS (Continued)

SPI Operation

The serial port of the Z86229 may be configured to operate as an I²C or SPI interface. The Z86229 always acts as the slave device with the master generating the required clock and input data signals. Two C language programs available from ZiLOG enable a PC to perform as the I²C or SPI master device of an application. The PC communicates with the Z86229 through its parallel port. These programs are not intended as examples of how to program the application, but are only provided as a means of illustrating the serial control process.

The two programs available, SEROUT and SCRIPT, are the SPI equivalent to the I²C programs IICO and SCRIPTI, respectively.

SEROUT Program

This program sends one byte to the Z86229 without checking the status of the READY bit. The program returns the contents of the Serial Status (SS) Register after the command has been entered. When the program is active the screen displays:

```
SPI Command Byte >
```

SPI Command Byte

The user may enter any valid one-byte command, such as 00h (NOP), and then hit the ENTER key. The screen then displays the byte entered and the SS register contents as follows:

```
SPI Byte = 00
```

```
SPI Return Val = 83h
```

The illustration above shows the NOP command was entered. The SS register contents, 83h, indicates that the RDY,

FLD, and LOCK bits are “ones”. This condition indicates that the serial port is ready for further input, that the input video signal was in Field 1 at the time the status was read, and that the part is operating in the video-lock mode.

When this program is used, only a modified version of the RESET can be used. It is entered as two, one-byte commands (FBh and 00h).

The SEROUT program is exited by entering a Control C (^C) character.

Script Program

This program is designed to send any number of one or two-byte commands to the Z86229. The list of commands to be executed are contained in Script files that have the extension .SER. The Script files used with the I²C version, SCRIPTI, can be used with this program.

The program is invoked by typing:

```
SI File_name<ENTER>
```

Note: Enter the file_name without the .SER extension.

The screen displays:

```
EEG CCD2 Serial Interface Script Player  
Version x.xx
```

```
Script File Done
```

When all the commands in the file have been successfully sent to the Z86229, the PC returns to the system prompt.

The program checks the RDY status before sending each byte. If, during the entry of a command, the RDY bit is not found to be a “one”, the program reports the contents of the SS register and then continue checking for RDY.

APPLICATION INFORMATION

The recommended schematic, component placement, and PCB layout for a single-sided DIP design are provided in the following figures. EMI and noise in the video frequency range is kept to an absolute minimum by running the ground plane underneath the entire Z86229 package length. This design is recommended for both SOIC and DIP package styles. Though it is not shown in the following application information, the SMS (pin 6) must be grounded for I²C application. If necessary, please contact your local ZiLOG sales office with any questions regarding this or other information represented in this document.

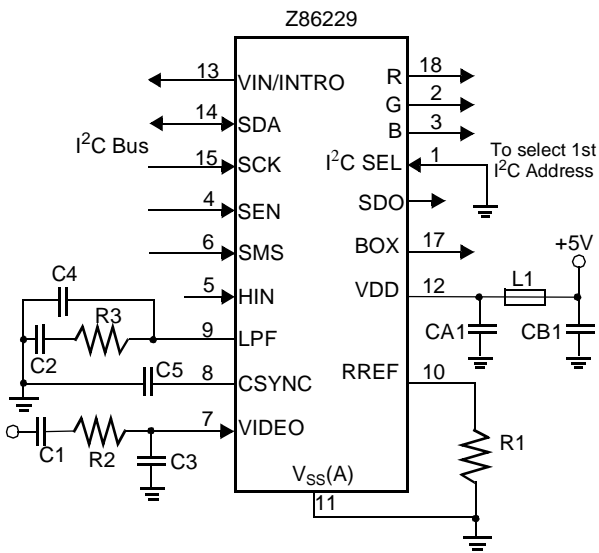
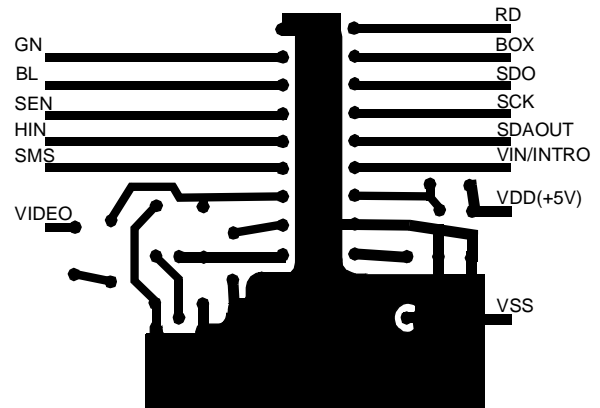

Figure 29. Z86229 Application Circuit with I²C

Figure 30. Z86229 Application Circuit with I²C

Table 22. Recommended Component Values for the Z86229 Application Circuit

Component	Value	Units
R1	10	KΩ
R2	470	Ω
R3	6.8	KΩ
C1	0.1	μF
C2	0.068	μF
C3	560	pF
C4	6800	pF
C5	0.1	μF
CA1	0.1	μF
CB1	0.1	μF
L1	bead	TBD
U1	Z86229	N/A

PACKAGING INFORMATION

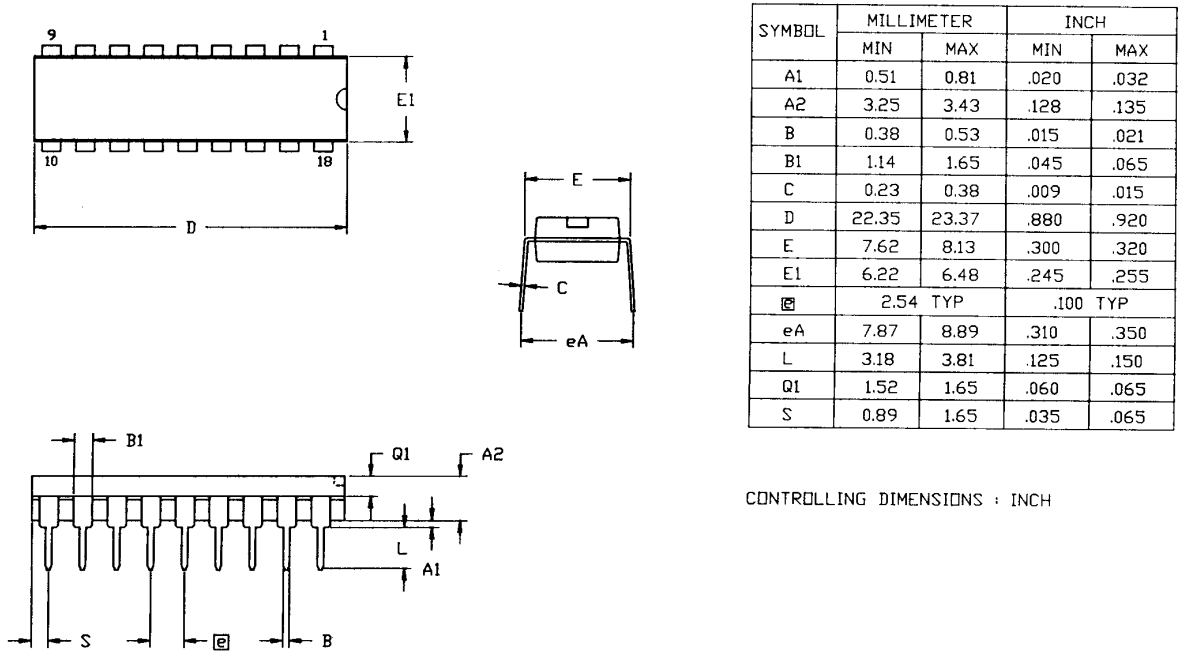

Figure 31. 18-Lead DIP Package Diagram

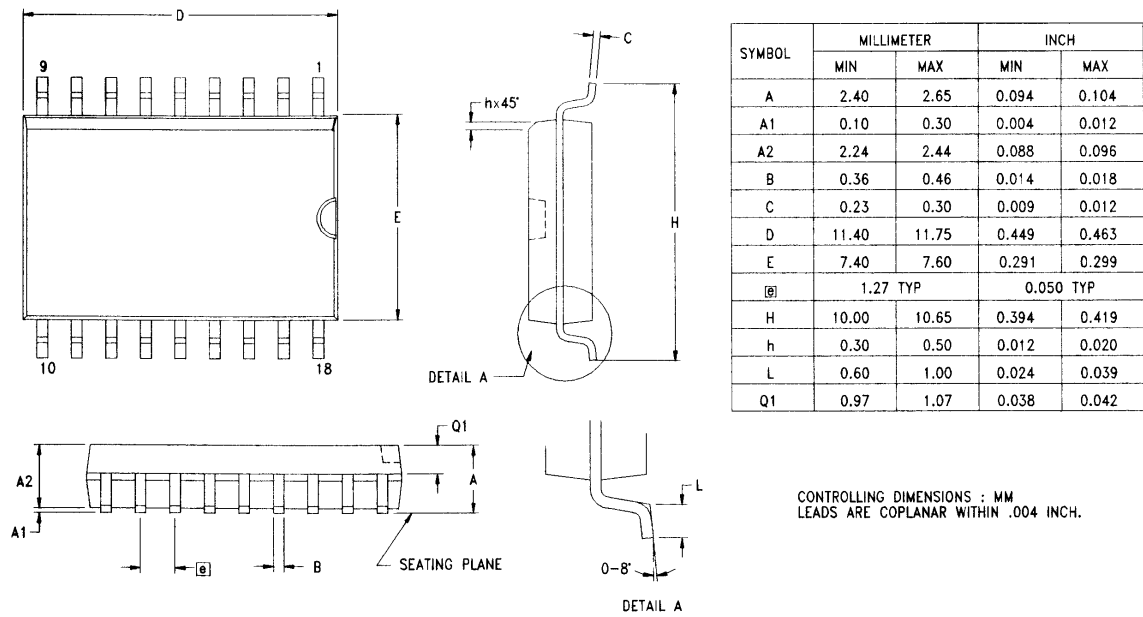

Figure 32. 18-Lead SOIC Package Diagram

ORDERING INFORMATION

Z86229 (12 MHz)	
18-Pin DIP	18-Pin SOIC
Z8622912PSC	Z8622912SSC

For fast results, contact your local ZiLOG sales office for assistance in ordering the part required.

CODES

Package	P = Plastic DIP S = Plastic SOIC
Temperature	S = 0°C to + 70°C
Speed	12 = 12 MHz
Environmental	C = Plastic Standard

Example:

Z 86229 12 P S C is a Z86229, 12 MHz, DIP, 0°C to + 70°C, Plastic Standard Flow

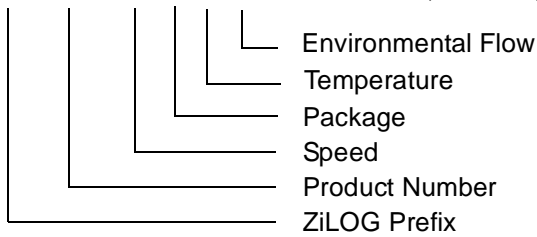

Pre-Characterization Product

The product represented by this document is newly introduced and ZiLOG has not completed the full characterization of the product. The document states what ZiLOG knows about this product at this time, but additional features or nonconformance with some aspects of the document may be found, either by ZiLOG or its customers in the course of further application and characterization work. In addition, ZiLOG cautions that delivery may be uncertain at times, due to start-up yield issues.

Development Projects

Customer is cautioned that while reasonable efforts will be employed to meet performance objectives and milestone dates, development is subject to unanticipated problems and delays. No production release is authorized or committed until the Customer and ZiLOG have agreed upon a Product Specification for this product.

Low Margin

Customer is advised that this product does not meet ZiLOG's internal guardbanded test policies for the specification requested and is supplied on an exception basis. Customer is cautioned that delivery may be uncertain and that, in addition to all other limitations on ZiLOG liability stated on the front and back of the acknowledgment, ZiLOG makes no claim as to quality and reliability according to the Data Sheet. The product remains subject to standard warranty for replacement due to defects in materials and workmanship.

Document Disclaimer

©2001 by ZiLOG, Inc. All rights reserved. Information in this publication concerning the devices, applications, or technology described is intended to suggest possible uses and may be superseded. ZiLOG, INC. DOES NOT ASSUME LIABILITY FOR OR PROVIDE A REPRESENTATION OF ACCURACY OF THE INFORMATION, DEVICES, OR TECHNOLOGY DESCRIBED IN THIS DOCUMENT. ZiLOG ALSO DOES NOT ASSUME LIABILITY FOR INTELLECTUAL PROPERTY INFRINGEMENT RELATED IN ANY MANNER TO USE OF INFORMATION, DEVICES, OR TECHNOLOGY DESCRIBED HEREIN OR OTHERWISE. Devices sold by ZiLOG, Inc. are covered by warranty and limitation of liability provisions appearing in the ZiLOG, Inc. Terms and Conditions of Sale. ZiLOG, Inc. makes no warranty of merchantability or fitness for any purpose. Except with the express written approval of ZiLOG, use of information, devices, or technology as critical components of life support systems is not authorized. No licenses are conveyed, implicitly or otherwise, by this document under any intellectual property rights.