

# XPT IGBT phaseleg

## ISOPLUS™

### Surface Mount Power Device

$$I_{C25} = 43 \text{ A}$$

$$V_{CES} = 1200 \text{ V}$$

$$V_{CE(sat) \text{ typ}} = 1.9 \text{ V}$$

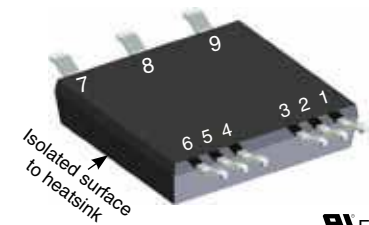
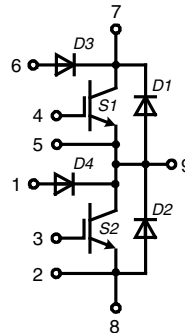

E72873

**IGBTs S1, S2**

Symbol	Conditions	Maximum Ratings
$V_{CES}$	$T_{VJ} = 25^{\circ}\text{C to } 150^{\circ}\text{C}$	1200 V
$V_{GES}$		$\pm 20$ V
$I_{C25}$	$T_C = 25^{\circ}\text{C}$	43 A
$I_{C80}$	$T_C = 80^{\circ}\text{C}$	30 A
$I_{CM}$ $V_{CEK}$	$V_{GE} = 15 \text{ V}; R_G = 39 \Omega; T_{VJ} = 125^{\circ}\text{C}$ RBSOA, clamped inductive load; $L = 100 \mu\text{H}$	75 A $V_{CES}$
$t_{SC}$ (SCSOA)	$V_{CE} = 900 \text{ V}; V_{GE} = \pm 15 \text{ V}; R_G = 39 \Omega; T_{VJ} = 125^{\circ}\text{C}$ none repetitive	10 $\mu\text{s}$
$P_{tot}$	$T_C = 25^{\circ}\text{C}$	150 W

Symbol	Conditions	Characteristic Values				
( $T_{VJ} = 25^{\circ}\text{C}$ , unless otherwise specified)						
		min.	typ.	max.		
$V_{CE(sat)}$	$I_C = 25 \text{ A}; V_{GE} = 15 \text{ V}; T_{VJ} = 25^{\circ}\text{C}$ $T_{VJ} = 125^{\circ}\text{C}$		1.9 2.2	2.2	V V	
$V_{GE(th)}$	$I_C = 1 \text{ mA}; V_{GE} = V_{CE}$	5.4		6.5	V	
$I_{CES}$	$V_{CE} = V_{CES}; V_{GE} = 0 \text{ V}; T_{VJ} = 25^{\circ}\text{C}$ $T_{VJ} = 125^{\circ}\text{C}$		200	2.1	mA $\mu\text{A}$	
$I_{GES}$	$V_{CE} = 0 \text{ V}; V_{GE} = \pm 20 \text{ V}$			500	nA	
$t_{d(on)}$ $t_r$ $t_{d(off)}$ $t_f$ $E_{on}$ $E_{off}$ $E_{(rec)off}$	Inductive load; $T_{VJ} = 125^{\circ}\text{C}$ $V_{CE} = 600 \text{ V}; I_C = 25 \text{ A}$ $V_{GE} = \pm 15 \text{ V}; R_G = 39 \Omega$		70 40 250 100 2.5 3.0 tbd		ns ns ns ns mJ mJ	
$C_{ies}$		$V_{CE} = 25 \text{ V}; V_{GE} = 0 \text{ V}; f = 1 \text{ MHz}$		tbd		pF
$Q_{Gon}$		$V_{CE} = 600 \text{ V}; V_{GE} = 15 \text{ V}; I_C = 25 \text{ A}$		76		nC
$R_{thJC}$					0.85	K/W
$R_{thJH}$		with heatsink compound (IXYS test setup)		0.95	1.3	K/W

**Features**

- **XPT IGBT**
  - low saturation voltage
  - positive temperature coefficient for easy paralleling
  - fast switching
  - short tail current for optimized performance in resonant circuits
- **Sonic™ diode**
  - fast reverse recovery
  - low operating forward voltage
  - low leakage current
- **$V_{CE(sat)}$  detection diode**
  - integrated into package
  - very fast diode
- **Package**
  - isolated back surface
  - low coupling capacity between pins and heatsink
  - PCB space saving
  - enlarged creepage towards heatsink
  - application friendly pinout
  - low inductive current path
  - high reliability

**Applications**

- **Phaseleg**
  - buck-boost chopper
- **Full bridge**
  - power supplies
  - induction heating
  - four quadrant DC drives
  - controlled rectifier
- **Three phase bridge**
  - AC drives
  - controlled rectifier

**Diodes D1, D2**

Symbol	Conditions	Maximum Ratings			
$I_{F25}$	$T_C = 25^\circ\text{C}$	40	A		
$I_{F80}$	$T_C = 80^\circ\text{C}$	27	A		
Symbol	Conditions	Characteristic Values			
( $T_{VJ} = 25^\circ\text{C}$ , unless otherwise specified)					
		min.	typ.	max.	
$V_F$	$I_F = 20\text{ A}$		1.9	2.4	V
			1.9		V
$I_{RM}$	$I_F = 20\text{ A}; R_G = 39\ \Omega; T_{VJ} = 125^\circ\text{C}$ $V_R = 600\text{ V}; V_{GE} = -15\text{ V}$		30		A
$t_{rr}$			350		ns
$E_{rec}$			0.85		mJ
$R_{thJC}$	per diode			0.9	K/W
$R_{thJH}$	with heatsink compound (IXYS test setup)		1.2	1.5	K/W

**Diodes D3, D4**

Symbol	Conditions	Maximum Ratings			
$V_R$	$T_C = 25^\circ\text{C}$ to $150^\circ\text{C}$	1200	V		
Symbol	Conditions	Characteristic Values			
( $T_{VJ} = 25^\circ\text{C}$ , unless otherwise specified)					
		min.	typ.	max.	
$V_F$	$I_F = 1\text{ A}$		1.7	2.2	V
			1.5		V
$I_R$	$V_R = 1200\text{ V}$			2	$\mu\text{A}$
			30		$\mu\text{A}$
$I_{RM}$	$I_F = 1\text{ A}; di_F/dt = -100\text{ A}/\mu\text{s}; T_{VJ} = 25^\circ\text{C}$ $V_R = 100\text{ V}; V_{GE} = 0\text{ V}$		2.3		A
$t_{rr}$			40		ns

**Component**

Symbol	Conditions	Maximum Ratings			
$T_{VJ}$		-55...+150	$^\circ\text{C}$		
$T_{stg}$		-55...+125	$^\circ\text{C}$		
$V_{ISOL}$	$I_{ISOL} \leq 1\text{ mA}; 50/60\text{ Hz}$	2500	V~		
$F_C$	mounting force	40 ... 130	N		
Symbol	Conditions	Characteristic Values			
		min.	typ.	max.	
$C_P$	coupling capacity between shorted pins and backside metal		90		pF
$d_S, d_A$	pin - pin	1.65			mm
$d_S, d_A$	pin - backside metal	4			mm
<b>CTI</b>		400			
<b>Weight</b>			8		g

Ordering	Ordering Name	Marking on Product	Delivering Mode	Base Qty	Ordering Code
Standard	IXA30PG1200DHGLB-TRR	IXA30PG1200DHGLB	Tape&Reel	200	511846

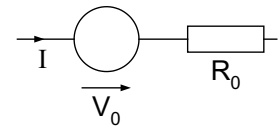
**Equivalent Circuits for Simulation**
**Conduction**

 IGBTs (typ. at  $V_{GE} = 15\text{ V}; T_J = 125^\circ\text{C}$ )  
 S1, S2  $V_0 = 1.1\text{ V}; R_0 = 60\text{ m}\Omega$ 

 Diodes (typ. at  $T_J = 125^\circ\text{C}$ )  
 D1, D2  $V_0 = 1.3\text{ V}; R_0 = 28\text{ m}\Omega$

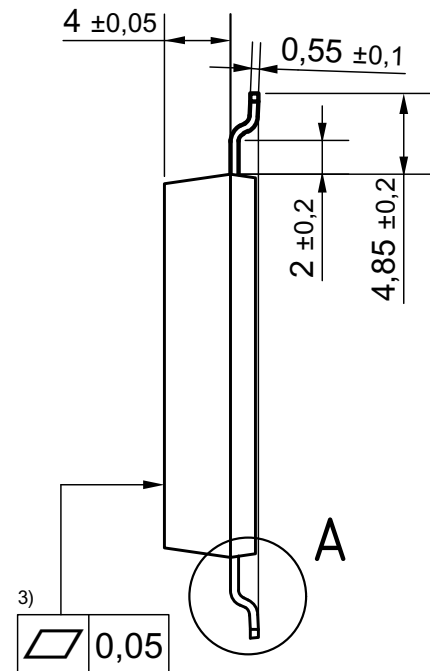
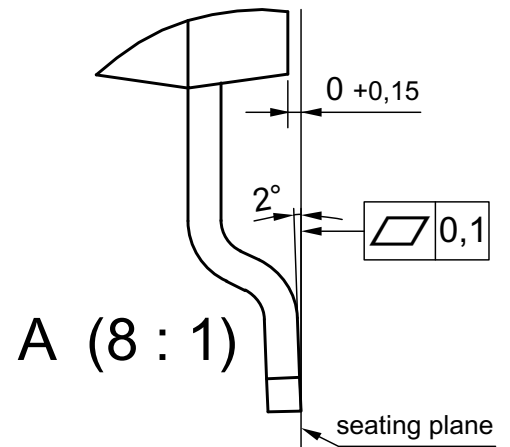
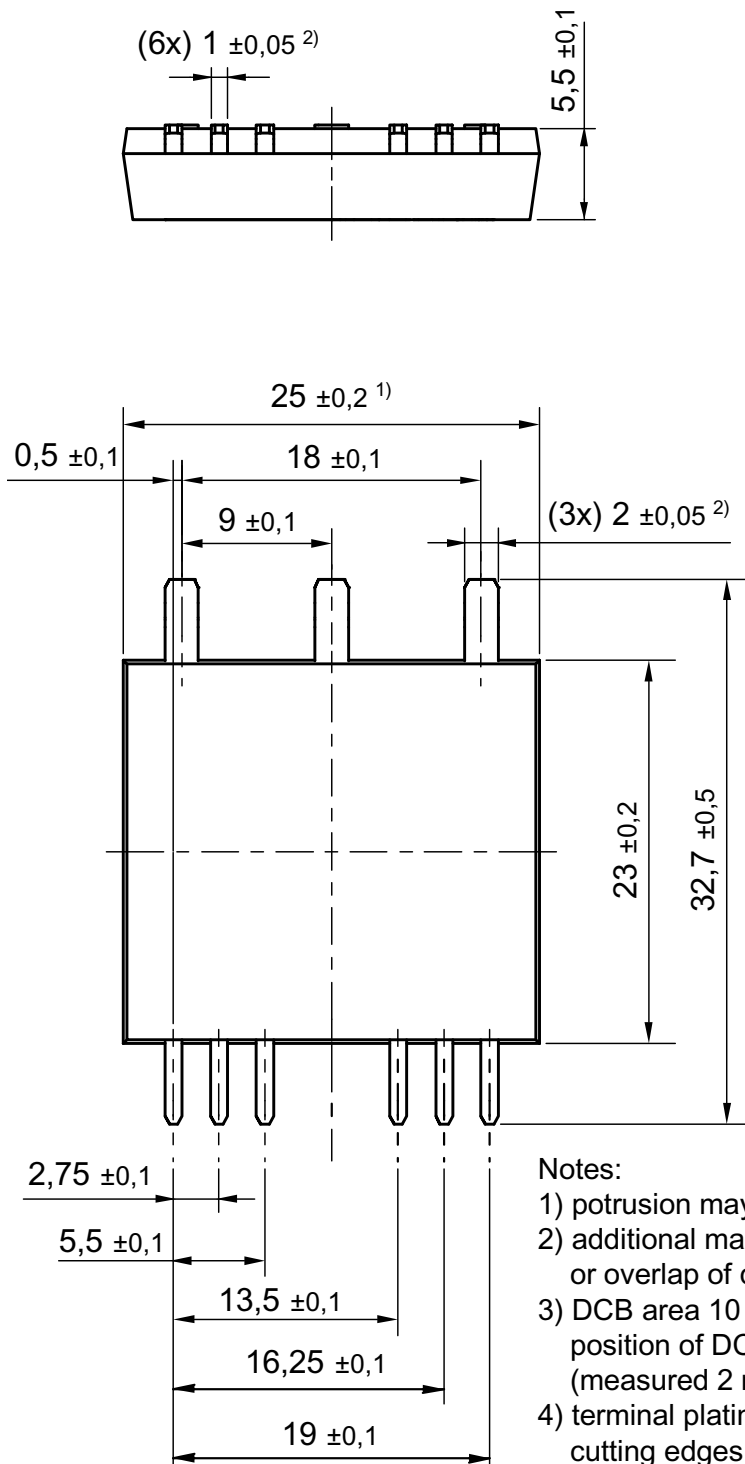
Dimensions in mm (1 mm = 0.0394")

**Notes:**

- 1) potrusion may add 0.2 mm max. on each side
- 2) additional max. 0.05 mm per side by punching misalignment or overlap of dam bar or bending compression
- 3) DCB area 10 to 50  $\mu\text{m}$  convex;  
position of DCB area in relation to plastic rim:  $\pm 25 \mu\text{m}$  (measured 2 mm from Cu rim)
- 4) terminal plating: 0.2 - 1  $\mu\text{m}$  Ni + 10 - 25  $\mu\text{m}$  Sn (gal v.)  
cutting edges may be partially free of plating

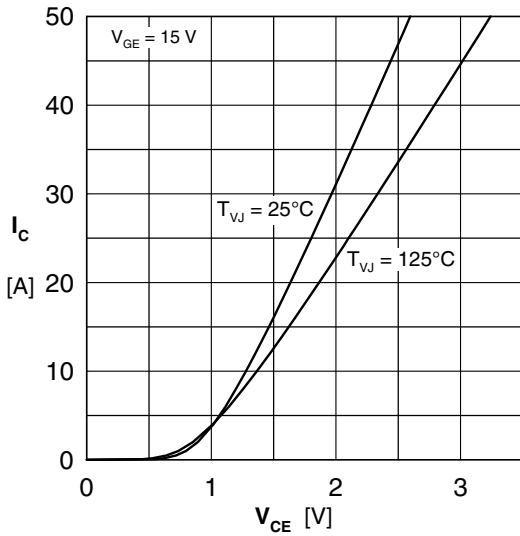

Fig. 1 Typ. output characteristics

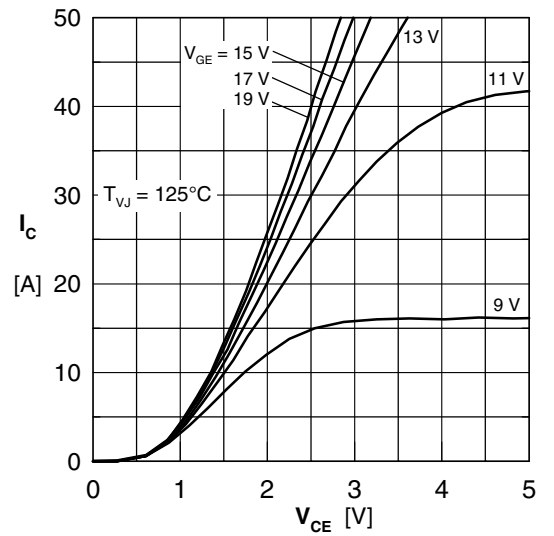

Fig. 2 Typ. output characteristics

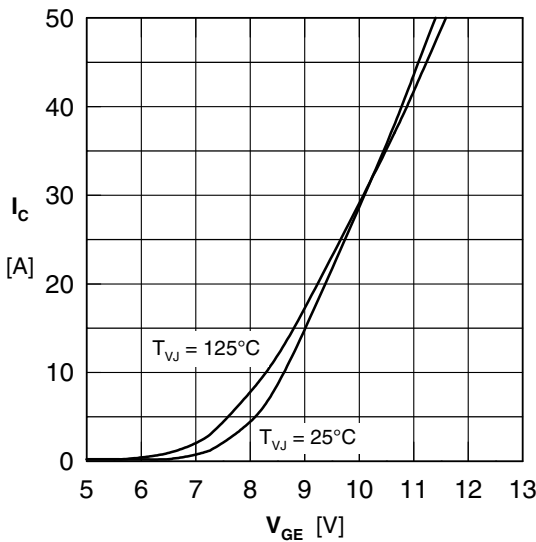

Fig. 3 Typ. transfer characteristics

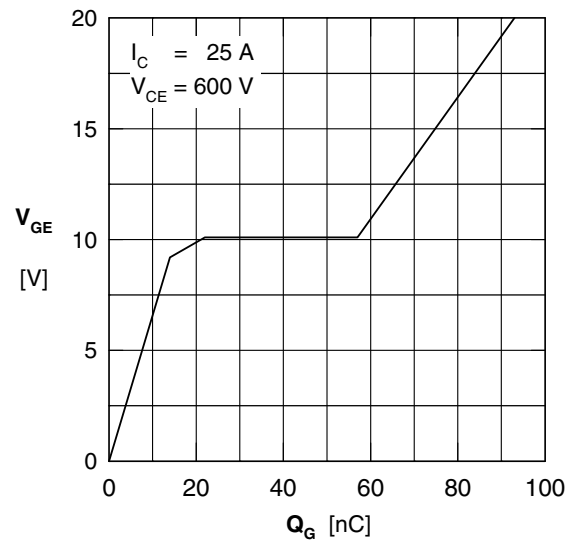

Fig. 4 Typ. turn-on gate charge

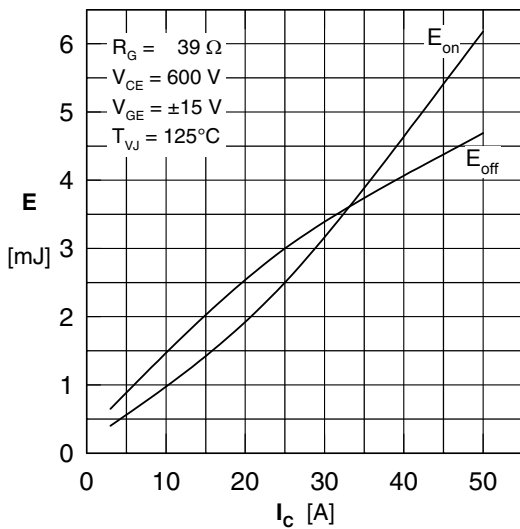

Fig. 5 Typ. switching energy vs. collector current

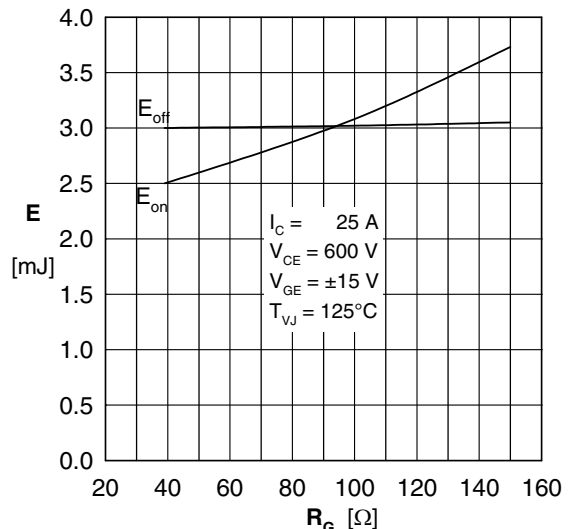

Fig. 6 Typ. switching energy vs. gate resistance

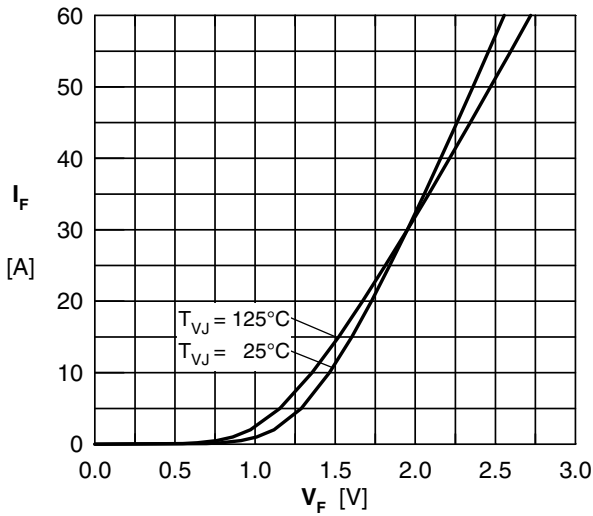

Fig. 7 Typ. Forward current versus  $V_F$

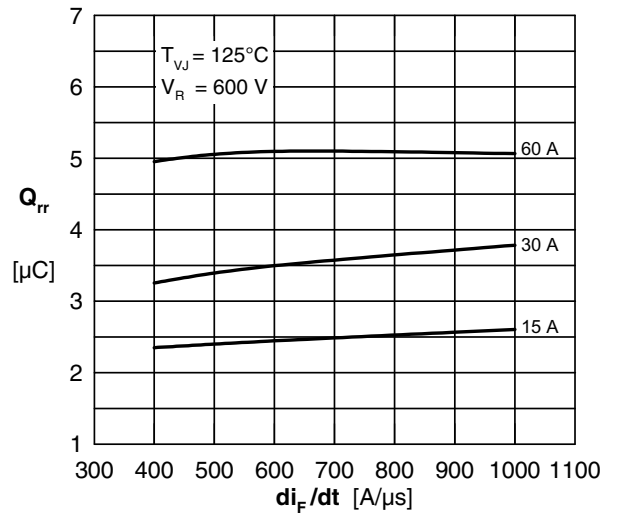

Fig. 8 Typ. reverse recov.charge  $Q_{rr}$  vs.  $di/dt$

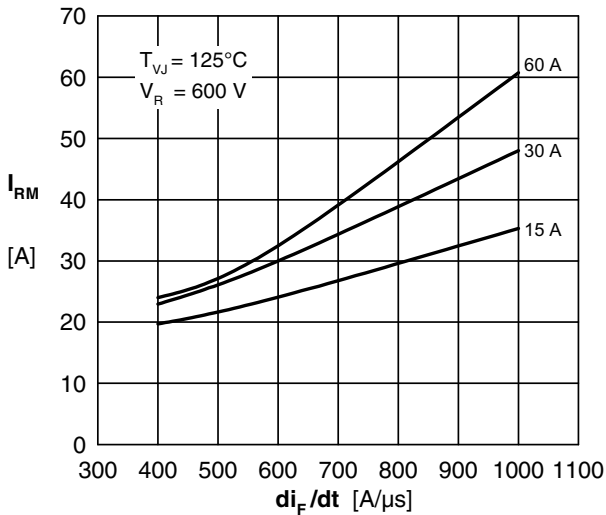

Fig. 9 Typ. peak reverse current  $I_{RM}$  vs.  $di/dt$

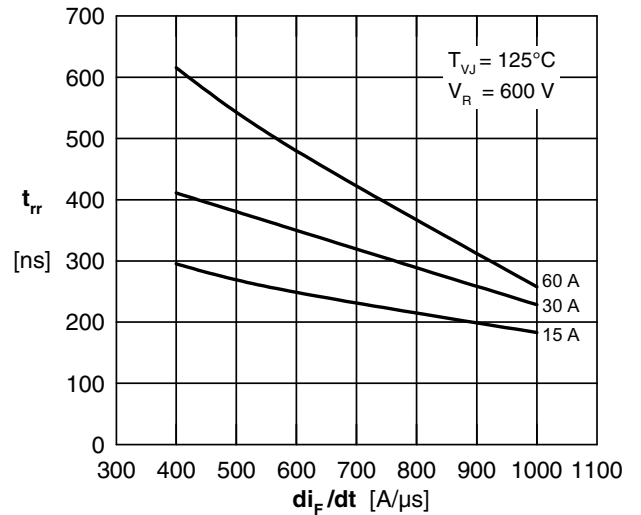

Fig.10 Typ. recovery time  $t_{rr}$  versus  $di/dt$

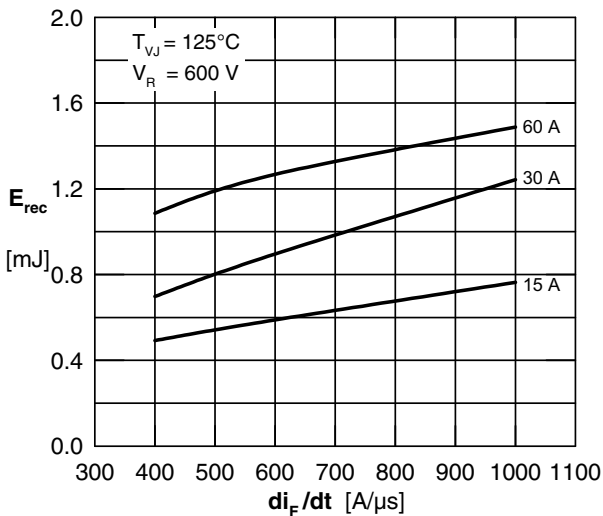

Fig.11 Typ. recovery energy  $E_{rec}$  versus  $di/dt$