

# High Voltage Phase Control Thyristor

## in High Voltage ISOPLUS i4-PAC™

$$\begin{aligned}
 V_{\text{DRM}} = V_{\text{RRM}} &= 2200 \text{ V} \\
 I_{\text{T(AV)}} &= 18 \text{ A} \\
 I_{\text{TSM}} &= 200 \text{ A}
 \end{aligned}$$

$V_{\text{RSM}}$ $V_{\text{DSM}}$ V	$V_{\text{RRM}}$ $V_{\text{DRM}}$ V	Type
2300	2200	CS 20-22moF1

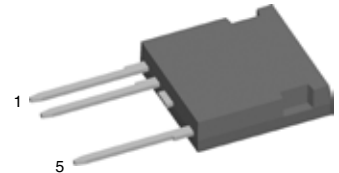
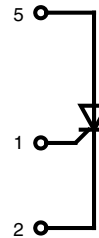

Thyristor					
Symbol	Conditions	Maximum Ratings			
$V_{\text{DRM}} / \text{RRM}$		2200	V		
$I_{\text{T(AV)}}$	sine 180°; $T_{\text{C}} = 90^{\circ}\text{C}$	18	A		
$I_{\text{T(AV)}}$	square; $d = 1/3$ ; $T_{\text{C}} = 90^{\circ}\text{C}$	16	A		
$I_{\text{TSM}}$	sine 180°; $t = 10 \text{ ms}$ ; $V_{\text{R}} = 0 \text{ V}$ ; $T_{\text{VJ}} = 25^{\circ}\text{C}$	200	A		
$(di/dt)_{\text{cr}}$	$T_{\text{VJ}} = T_{\text{VJM}}$ $f = 50 \text{ Hz}$ ; $t_{\text{p}} = 200 \mu\text{s}$ $V_{\text{D}} = 2/3 V_{\text{DRM}}$ $I_{\text{G}} = 0.45 \text{ A}$ $di_{\text{G}}/dt = 0.45 \text{ A}/\mu\text{s}$	repetitive, $I_{\text{T}} = 40 \text{ A}$	100	$\text{A}/\mu\text{s}$	
$(dv/dt)_{\text{cr}}$	$T_{\text{VJ}} = T_{\text{VJM}}$ ; $V_{\text{D}} = 2/3 V_{\text{DRM}}$ $R_{\text{GK}} = \infty$ ; method 1 (linear voltage rise)	non repetitive, $I_{\text{T}} = 20 \text{ A}$	250	$\text{A}/\mu\text{s}$	
			2500	$\text{V}/\mu\text{s}$	
Symbol	Conditions	Characteristic Values ( $T_{\text{VJ}} = 25^{\circ}\text{C}$ , unless otherwise specified)			
			typ.	max.	
$V_{\text{T}}$	$I_{\text{T}} = 20 \text{ A}$ ;	$T_{\text{VJ}} = 25^{\circ}\text{C}$ $T_{\text{VJ}} = 125^{\circ}\text{C}$	1.3 1.3	1.5	V
$V_{\text{GT}}$	$V_{\text{D}} = 6 \text{ V}$			2.3	V
$I_{\text{GT}}$				250	mA
$V_{\text{GD}}$	$V_{\text{D}} = 2/3 V_{\text{DRM}}$ ;	$T_{\text{VJ}} = T_{\text{VJM}}$		0.2	V
$I_{\text{GD}}$				5	mA
$I_{\text{L}}$	$t_{\text{p}} = 10 \mu\text{s}$ ; $V_{\text{D}} = 6 \text{ V}$ $I_{\text{G}} = 0.45 \text{ A}$ ; $di_{\text{G}}/dt = 0.45 \text{ A}/\mu\text{s}$			500	mA
$I_{\text{H}}$	$V_{\text{D}} = 6 \text{ V}$ ; $R_{\text{GK}} = \infty$			150	mA
$t_{\text{gd}}$	$V_{\text{D}} = 1/2 V_{\text{DRM}}$ $I_{\text{G}} = 0.45 \text{ A}$ ; $di_{\text{G}}/dt = 0.45 \text{ A}/\mu\text{s}$			2	$\mu\text{s}$
$I_{\text{R}}, I_{\text{D}}$	$V_{\text{R}} = V_{\text{RRM}}$ ; $V_{\text{D}} = V_{\text{DRM}}$ ;	$T_{\text{VJ}} = 25^{\circ}\text{C}$ $T_{\text{VJ}} = 125^{\circ}\text{C}$		50	$\mu\text{A}$ mA
$R_{\text{thJC}}$	DC current			0.92	K/W

### Features

- high voltage thyristor
  - for line frequency
  - chip technology for long term stability
- ISOPLUS i4-PAC™
  - high voltage package
  - isolated back surface
  - enlarged creepage towards heatsink
  - enlarged creepage between high voltage pins
  - application friendly pinout
  - high reliability
  - industry standard outline

### Applications

- controlled rectifiers
  - power supplies
  - drives
- AC switches
- capacitor discharge control
  - flash tubes
  - X-ray and laser generators

Component			
Symbol	Conditions	Maximum Ratings	
$T_{VJ}$		-40 ... +125	°C
$T_{stg}$		-55 ... +125	°C
$V_{ISOL}$	$I_{ISOL} \leq 1 \text{ mA}; 50/60 \text{ Hz}$	2500	V~
$F_C$	mounting force with clip	20...120	N

Symbol	Conditions	Characteristic Values	
		min.	typ.
$d_s, d_A$	A pin - K pin	7	mm
	pin - backside metal	5.5	mm
$R_{thCH}$	with heatsink compound		0.15 K/W
<b>Weight</b>			5.5 g

Dimensions in mm (1 mm = 0.0394")

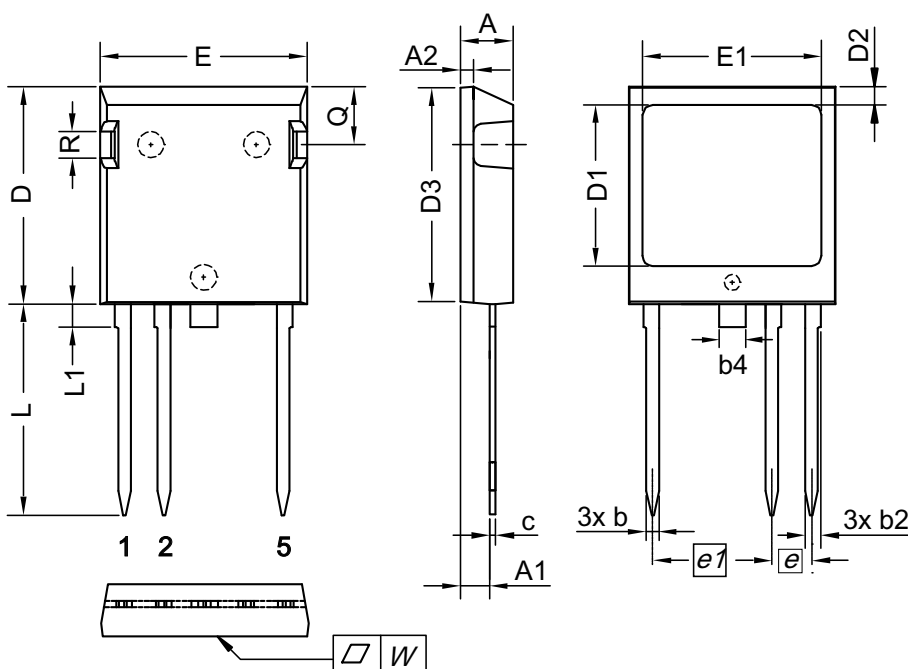

Dim.	Millimeter		Inches	
	min	max	min	max
A	4.83	5.21	0.190	0.205
A1	2.59	3.00	0.102	0.118
A2	1.17	2.16	0.046	0.085
b	1.14	1.40	0.045	0.055
b2	1.47	1.73	0.058	0.068
b4	2.54	2.79	0.100	0.110
c	0.51	0.74	0.020	0.029
D	20.80	21.34	0.819	0.840
D1	14.99	15.75	0.590	0.620
D2	1.65	2.03	0.065	0.080
D3	20.30	20.70	0.799	0.815
E	19.56	20.29	0.770	0.799
E1	16.76	17.53	0.660	0.690
e	3.81 BSC		0.150 BSC	
e1	11.43 BSC		0.450 BSC	
L	19.81	21.34	0.780	0.840
L1	2.11	2.59	0.083	0.102
Q	5.33	6.20	0.210	0.244
R	2.54	4.57	0.100	0.180
W	-	0.10	-	0.004

Die konvexe Form des Substrates ist typ. < 0.05 mm über der Kunststoffoberfläche der Bauteilunterseite  
 The convexbow of substrate is typ. < 0.05 mm over plastic surface level of device bottom side