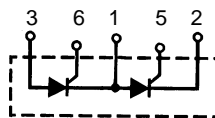
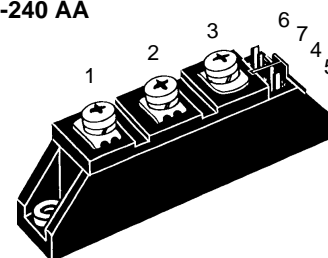

Thyristor Modules

V_{RSM}	V_{RRM}	Type
V_{DSM}	V_{DRM}	
V	V	
900	800	MCC 21-08io8 B
1300	1200	MCC 21-12io8 B
1500	1400	MCC 21-14io8 B
1700	1600	MCC 21-16io8 B

TO-240 AA

Symbol	Conditions	Maximum Ratings	
I_{TRMS}	$T_{VJ} = T_{VJM}$	33	A
I_{TAVM}	$T_C = 85^\circ\text{C}; 180^\circ$ sine	21	A
I_{TSM}	$T_{VJ} = 45^\circ\text{C}; V_R = 0$	$t = 10$ ms (50 Hz), sine	320 A
		$t = 8.3$ ms (60 Hz), sine	350 A
P_{dt}	$T_{VJ} = 45^\circ\text{C}; V_R = 0$	$t = 10$ ms (50 Hz), sine	500 A ² s
		$t = 8.3$ ms (60 Hz), sine	520 A ² s
$(di/dt)_{cr}$	$T_{VJ} = T_{VJM}; f = 50\text{Hz}, t_p = 200\mu\text{s}; V_D = 2/3 V_{DRM}; I_G = 0.45$ A $di_G/dt = 0.45$ A/ μs	repetitive, $I_T = 45$ A	150 A/ μs
		non repetitive, $I_T = I_{TAVM}$	500 A/ μs
$(dv/dt)_{cr}$	$T_{VJ} = T_{VJM}; V_{DR} = 2/3 V_{DRM}; R_{GK} = \infty$; method 1 (linear voltage rise)	1000	V/ μs
P_{GM}	$T_{VJ} = T_{VJM}; I_T = I_{TAVM}$	$t_p = 30$ μs	10 W
		$t_p = 300$ μs	5 W
P_{GAV}		0.5	W
V_{RGM}		10	V
T_{VJ}		-40...+125	$^\circ\text{C}$
T_{VJM}		125	$^\circ\text{C}$
T_{stg}		-40...+125	$^\circ\text{C}$
V_{ISOL}	50/60 Hz, RMS $I_{ISOL} \leq 1$ mA	$t = 1$ min	3000 V~
		$t = 1$ s	3600 V~
M_d	Mounting torque (M5)	2.5-4.0/22-35	Nm/lb.in.
	Terminal connection torque (M5)	2.5-4.0/22-35	Nm/lb.in.
Weight	Typical including screws	90	g

Features

- International standard package, JEDEC TO-240 AA
- Direct copper bonded Al_2O_3 -ceramic base plate
- Planar passivated chips
- Isolation voltage 3600 V~
- UL registered, E 72873
- Gate-cathode twin pins for version 1B

Applications

- DC motor control
- Softstart AC motor controller
- Light, heat and temperature control

Advantages

- Space and weight savings
- Simple mounting with two screws
- Improved temperature and power cycling
- Reduced protection circuits

Data according to DIN/IEC 747 and refer to a single thyristor unless otherwise stated.

Symbol	Conditions	Characteristic Values
I_{RRM}, I_{DRM}	$T_{VJ} = T_{VJM}; V_R = V_{RRM}; V_D = V_{DRM}$	5 mA
V_T	$I_T = 45 \text{ A}; T_{VJ} = 25^\circ\text{C}$	1.6 V
V_{T0}	For power-loss calculations only ($T_{VJ} = 125^\circ\text{C}$)	0.85 V
r_T		15 mΩ
V_{GT}	$V_D = 6 \text{ V}; T_{VJ} = 25^\circ\text{C}$ $T_{VJ} = -40^\circ\text{C}$	1.0 V 1.2 V
I_{GT}	$V_D = 6 \text{ V}; T_{VJ} = 25^\circ\text{C}$ $T_{VJ} = -40^\circ\text{C}$	65 mA 80 mA
V_{GD}	$T_{VJ} = T_{VJM}; V_D = \frac{2}{3} V_{DRM}$	0.2 V
I_{GD}		5 mA
I_L	$T_{VJ} = 25^\circ\text{C}; t_p = 10 \mu\text{s}; V_D = 6 \text{ V}$ $I_G = 0.3 \text{ A}; di_G/dt = 0.3 \text{ A}/\mu\text{s}$	150 mA
I_H	$T_{VJ} = 25^\circ\text{C}; V_D = 6 \text{ V}; R_{GK} = \infty$	100 mA
t_{gd}	$T_{VJ} = 25^\circ\text{C}; V_D = \frac{1}{2} V_{DRM}$ $I_G = 0.3 \text{ A}; di_G/dt = 0.3 \text{ A}/\mu\text{s}$	2 μs
t_q	$T_{VJ} = T_{VJM}; I_T = 15 \text{ A}, t_p = 300 \mu\text{s}; -di/dt = 10 \text{ A}/\mu\text{s}$ typ. $V_R = 100 \text{ V}; dv/dt = 20 \text{ V}/\mu\text{s}; V_D = \frac{2}{3} V_{DRM}$	150 μs
I_{RM}	$T_{VJ} = T_{VJM}; I_T = 30 \text{ A}, -di/dt = 0.3 \text{ A}/\mu\text{s}$	4 A
R_{thJC}	per thyristor; DC current	1.1 K/W
	per module	0.55 K/W
R_{thJK}	per thyristor; DC current	1.3 K/W
	per module	0.65 K/W
	other values see Fig. 8/9	
d_s	Creepage distance on surface	12.7 mm
d_A	Strike distance through air	9.6 mm
a	Maximum allowable acceleration	50 m/s ²

Optional accessories for module-type MCC 23 version 1 B
 Keyed gate/cathode twin plugs with wire length = 350 mm, gate = yellow, cathode = red
 Type **ZY 200L** (L = Left for pin pair 4/5) } UL 758, style 1385,
 Type **ZY 200R** (R = right for pin pair 6/7) } CSA class 5851, guide 460-1-1

Dimensions in mm (1 mm = 0.0394")

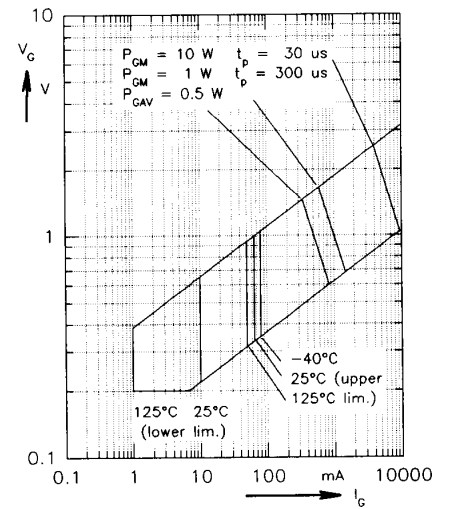
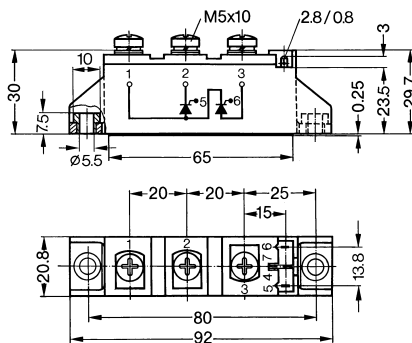

Fig. 1 Gate trigger characteristics

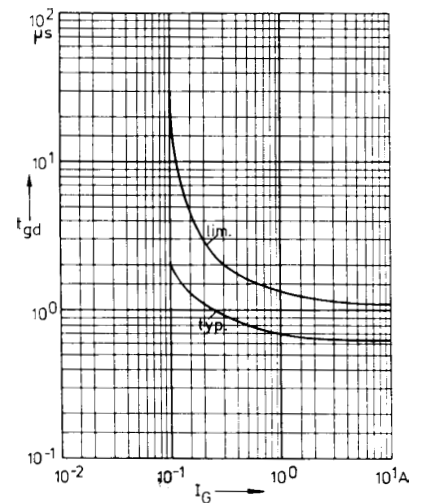

Fig. 2 Gate trigger delay time