

zilog[®]

Embedded in Life

An  IXYS Company

Z8051 Series 8-Bit Microcontrollers

ZGFI7101 Earth Leakage Detector

Product Specification

PS030402-0212

PRELIMINARY





Warning: DO NOT USE THIS PRODUCT IN LIFE SUPPORT SYSTEMS.

LIFE SUPPORT POLICY

ZILOG'S PRODUCTS ARE NOT AUTHORIZED FOR USE AS CRITICAL COMPONENTS IN LIFE SUPPORT DEVICES OR SYSTEMS WITHOUT THE EXPRESS PRIOR WRITTEN APPROVAL OF THE PRESIDENT AND GENERAL COUNSEL OF ZILOG CORPORATION.

As used herein

Life support devices or systems are devices which (a) are intended for surgical implant into the body, or (b) support or sustain life and whose failure to perform when properly used in accordance with instructions for use provided in the labeling can be reasonably expected to result in a significant injury to the user. A critical component is any component in a life support device or system whose failure to perform can be reasonably expected to cause the failure of the life support device or system or to affect its safety or effectiveness.

Document Disclaimer

©2012 Zilog, Inc. All rights reserved. Information in this publication concerning the devices, applications, or technology described is intended to suggest possible uses and may be superseded. ZILOG, INC. DOES NOT ASSUME LIABILITY FOR OR PROVIDE A REPRESENTATION OF ACCURACY OF THE INFORMATION, DEVICES, OR TECHNOLOGY DESCRIBED IN THIS DOCUMENT. ZILOG ALSO DOES NOT ASSUME LIABILITY FOR INTELLECTUAL PROPERTY INFRINGEMENT RELATED IN ANY MANNER TO USE OF INFORMATION, DEVICES, OR TECHNOLOGY DESCRIBED HEREIN OR OTHERWISE. The information contained within this document has been verified according to the general principles of electrical and mechanical engineering.

Z8051 is a trademark or registered trademark of Zilog, Inc. All other product or service names are the property of their respective owners.

Revision History

Each instance in this document's revision history reflects a change from its previous edition. For more details, refer to the corresponding page(s) or appropriate links furnished in the table below.

Date	Revision Level	Description	Page
Feb 2012	02	Removed references to wafer sale product option.	All
Jan 2012	01	Original Zilog issue.	All



Table of Contents

1.	General Description	2
2.	Features	2
3.	Ordering Information	2
4.	Pin Assignment	2
5.	Block Diagram	3
6.	Absolute Maximum Rating (TA = 25°C).....	4
7.	Recommended Operating Condition : Ta = -30°C to 85°C.....	4
8.	Electrical Characteristics.....	5
9.	Typical Performance Curves.....	6
10.	Test Circuit.....	7
11.	Typical Application.....	9
12.	Package Dimensions	10

1. General Description

The ZGFI7101 is designed for use in earth leakage circuit interrupters for operation directly off the AC Line in breakers. It contains pre-regulator, main-regulator, after-regulator, differential amplifier, level comparator, latch circuit. The input in the differential amplifier is connected to the secondary node of zero current transformer. The level comparator generates high level when earth leakage current is greater than some level.

2. Features

- Low Power consumption (PD = 5mW) 100V/ 200V
- 100V/200V Common Built-in Voltage Regulator
- High Gain Differential Amplifier
- High Input Sensitivity (VT = 13.5mV Typ.)
- Minimum External Parts
- Large Surge Margin
- Wide Operating Temperature Range (TA = -30 to 85°C)
- High Noise Immunity
- GL7101,M54122 pin compatible

3. Ordering Information

Device Name	Package
ZGFI7101JBT	8_SOP
ZGFI7101PBT	8_PDIP

4. Pin Assignment

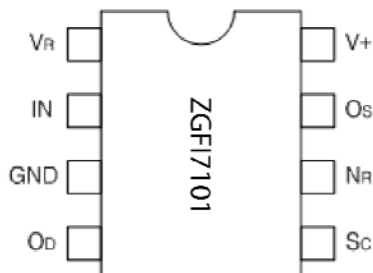

5. Block Diagram

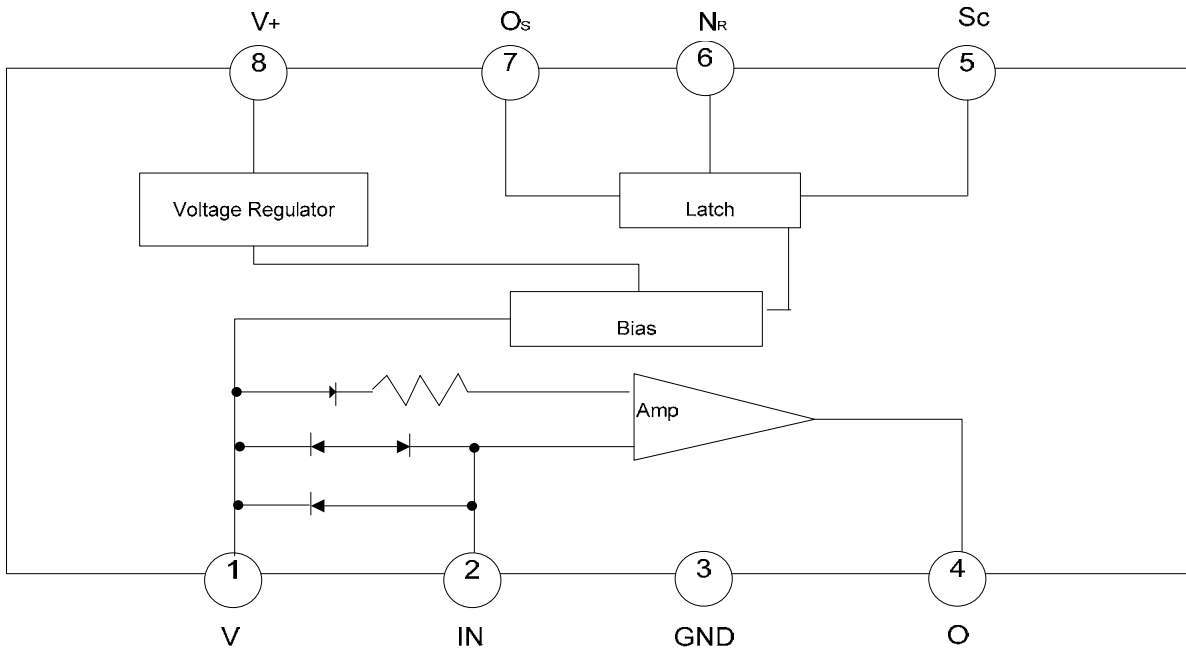



6. Absolute Maximum Rating (TA = 25°C)

Supply voltage	20	V
Supply Current	8	mA
Power Dissipation	200	mW
Operating Temperature	-30 to 85	
Storage Temperature	-55 to 125	

7. Recommended Operating Condition : Ta = -30°C to 85°C

PARAMETER	SYMBOL	MIN.	TYP.	MAX.	UNIT
Supply Voltage	V+	12			V
Vs-GND Capacitor	Cvs	1			uF
Os-GND Capacitor	Cos			1	uF

8. Electrical Characteristics

PARAMETER	SYMBOL	CONDITONS	TEMP (°C)	MIN.	TYP.	MAX.	UNIT	TEST CIRCUT
SupplyCurrent1	IS1	V+=12V, VR-VI=30mV	-30	-	-	580	uA	1
			25	-	400	530		
			85	-	-	480		
*Trip Voltage	VT	V+=16V. VR-VI=X	-30~85	9	13.5	18	mV(rms)	2
Differential Amplifier Output Current1	ITD1	V+=16V, VR-VI=30mV VOD=1.2V	25	-12	-	-30	uA	3
Differential Amplifier Output Current2	ITD2	V+=16V, VR-VI=short VOD=0.8V	25	17	-	37	uA	4
Output Current	Io	VSC=1.4V VOS=0.8V	IS1=580 uA	-30	-200	-	uA	5
			IS1=530 uA	25	-100	-		
			IS1=480 uA	85	-75	-		
Sc On Voltage	Vsc ON	V+=16V	25	0.7	-	1.4	V	6
Sc Input Current	Isc ON	V+=12V	25	-	-	5	uA	7
Output "L" Current	IosL	V+12V, VosL =0.2V	-30~85	200	-	-	uA	8
Input Clamp Voltage	Vic	V+=12V, Vic=20mA	-30~85	4.3	-	6.7	V	9
Differential Input Clamp Voltage	VIDC	IIDC = 100mV	-30~85	0.4	-	2	V	10
Max Current voltage	VSM	ISM=7mA	25	20	-	28	V	11
Supply Current 2	IS2	VOS=0.5V, VR-VI=X	-30~85	-	-	900	uA	12
Latch Circuit Off Supply Voltage	V+OFF		25	0.5	-		V	13
Response Time	TON	V+=16V, VR-VI=0.3V	25	1	-	4	ms	14

* A :9~12.55 ,B :11.5~15.5 ,C :14.5 ~ 18

9. Typical Performance Curves

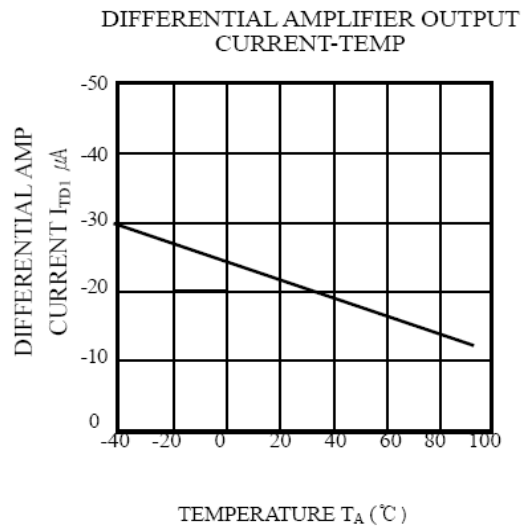
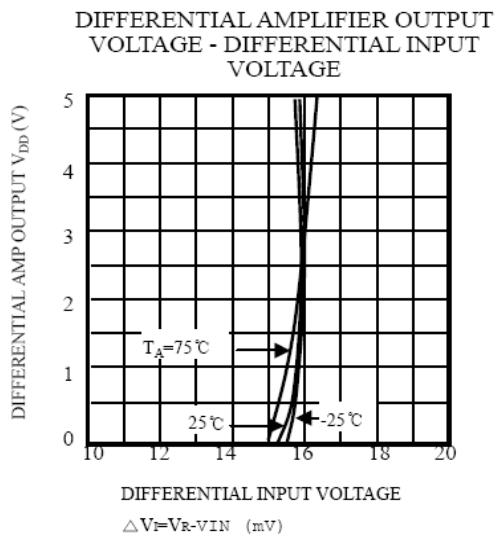
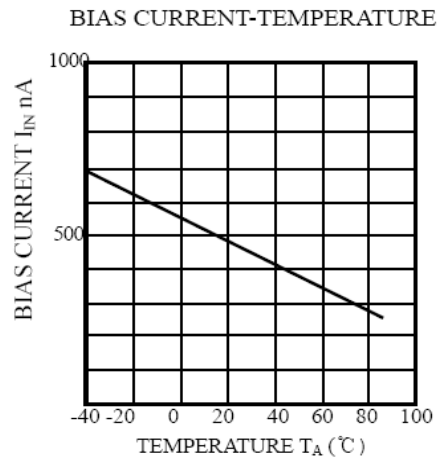
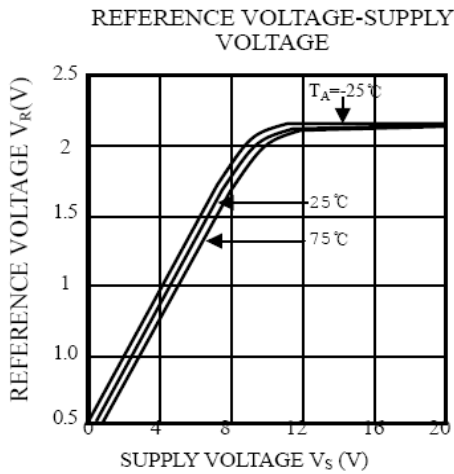
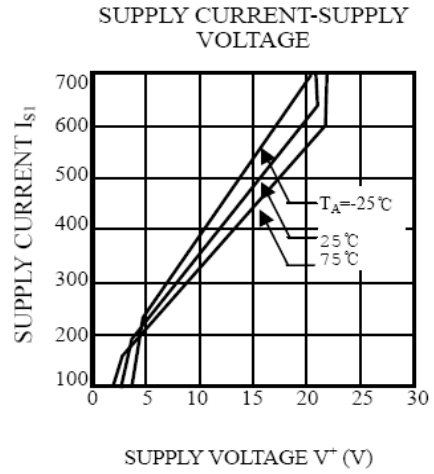
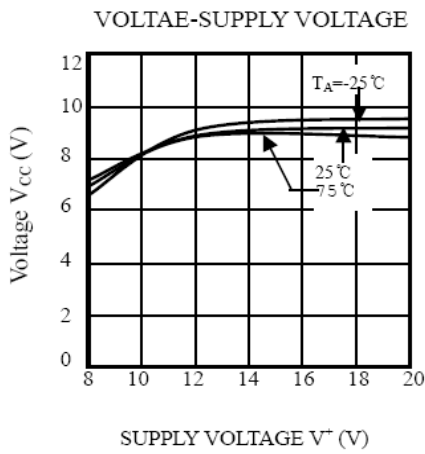

10. Test Circuit

1.

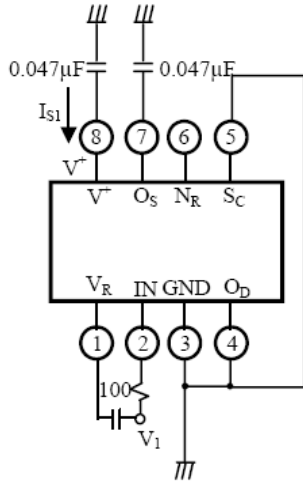

2.

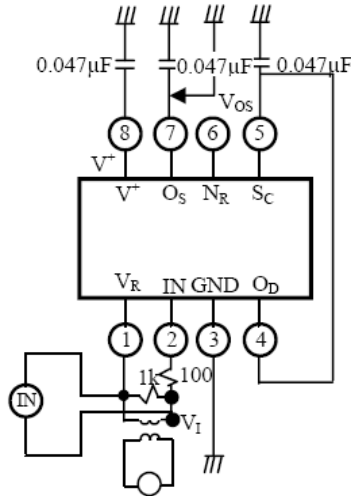

3.

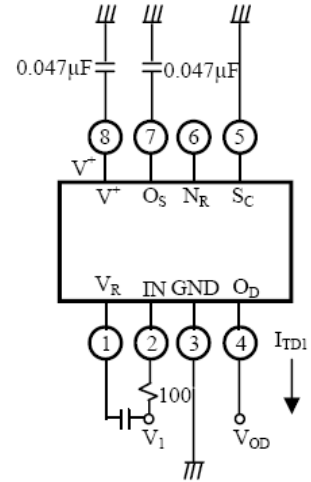

4.

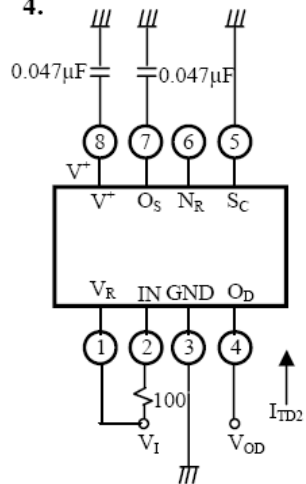

5.

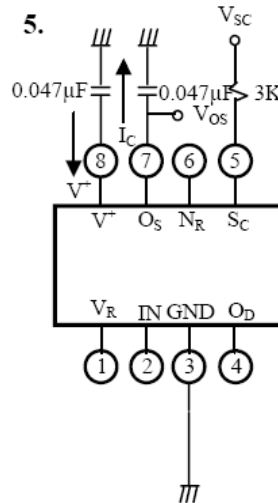

6.

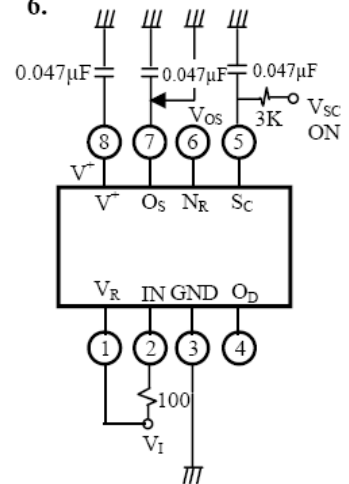

7.

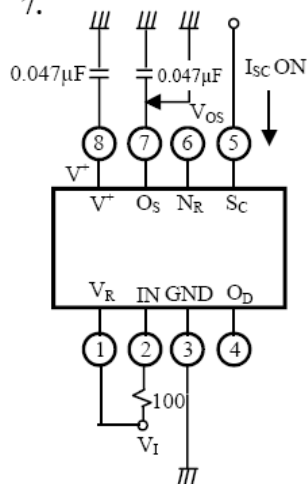

8.

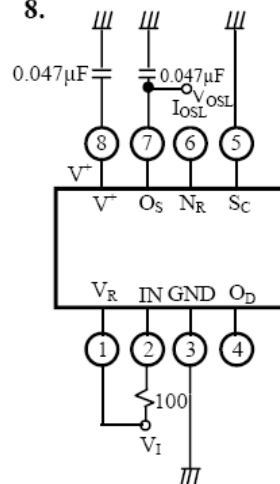

9.

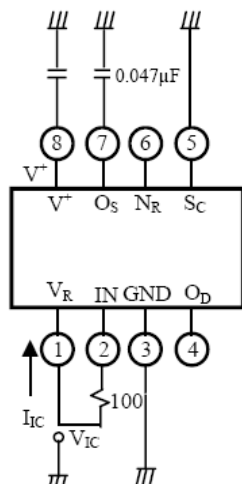

10.

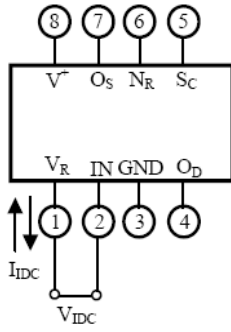

11.

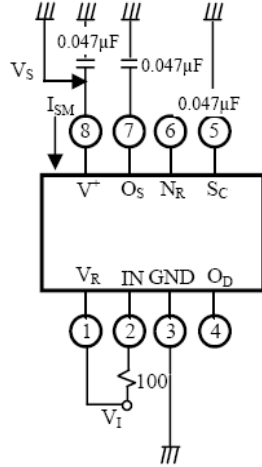

12.

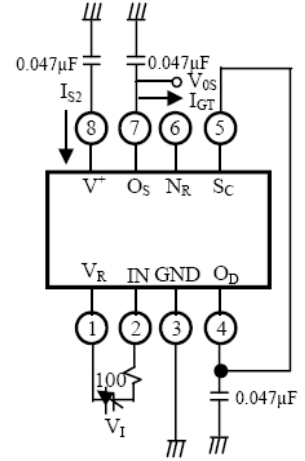

13.

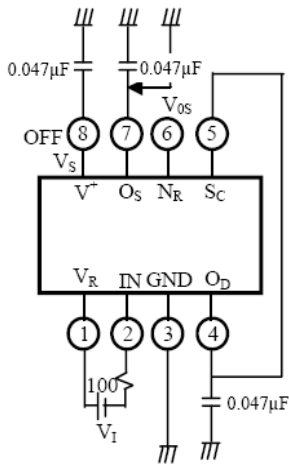

14.

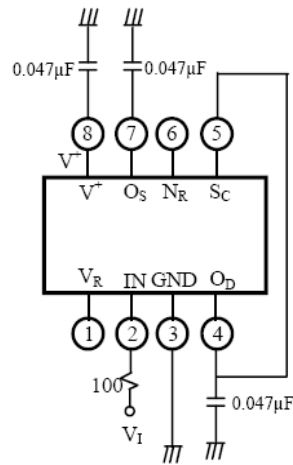

11. Typical Application

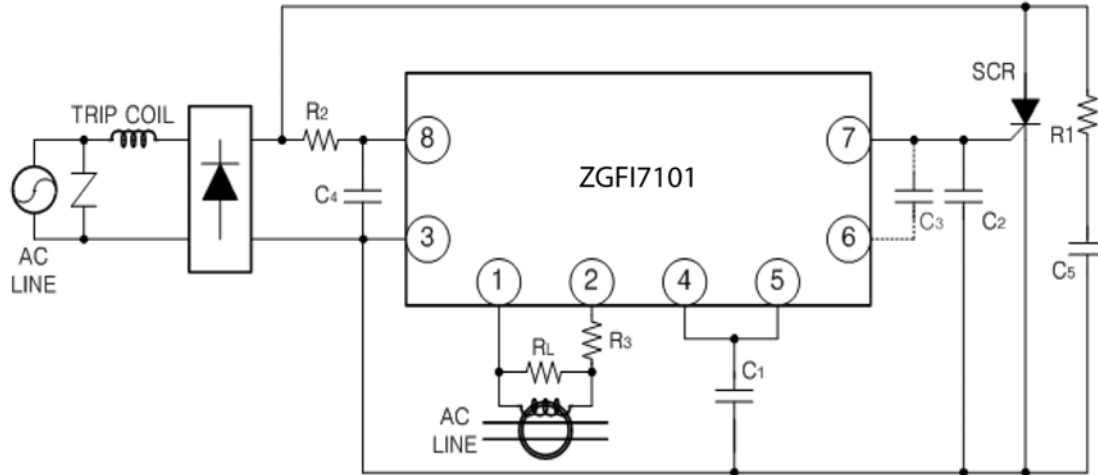

12. Package Dimensions 8DIP

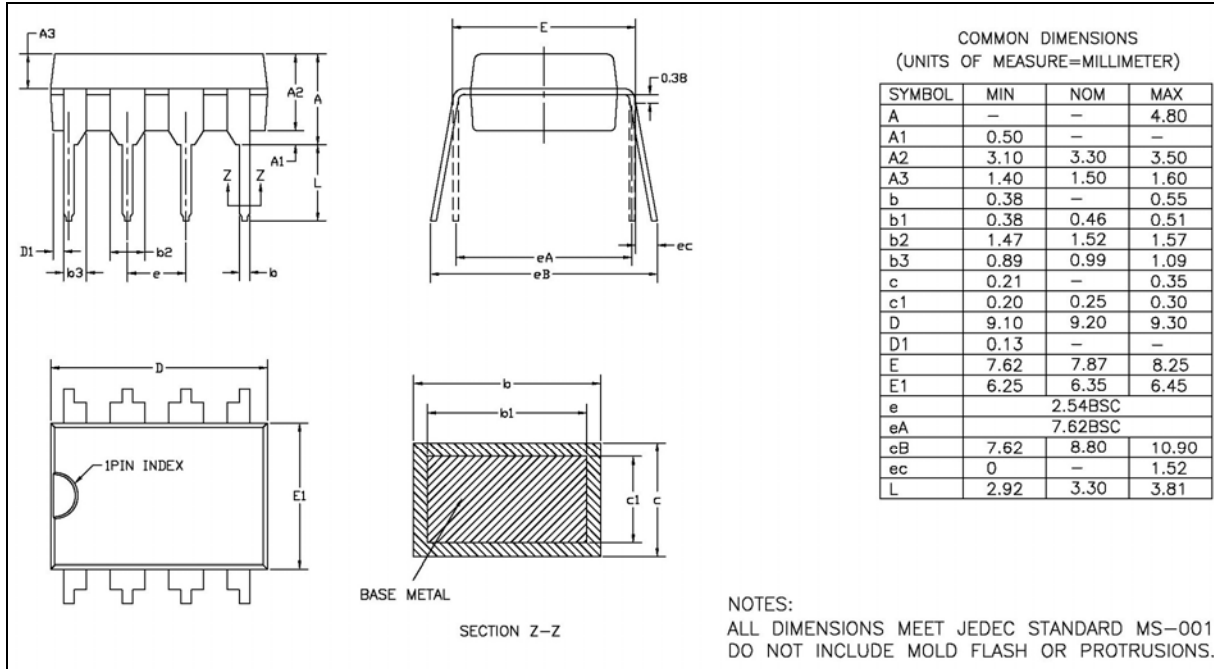

8SOP

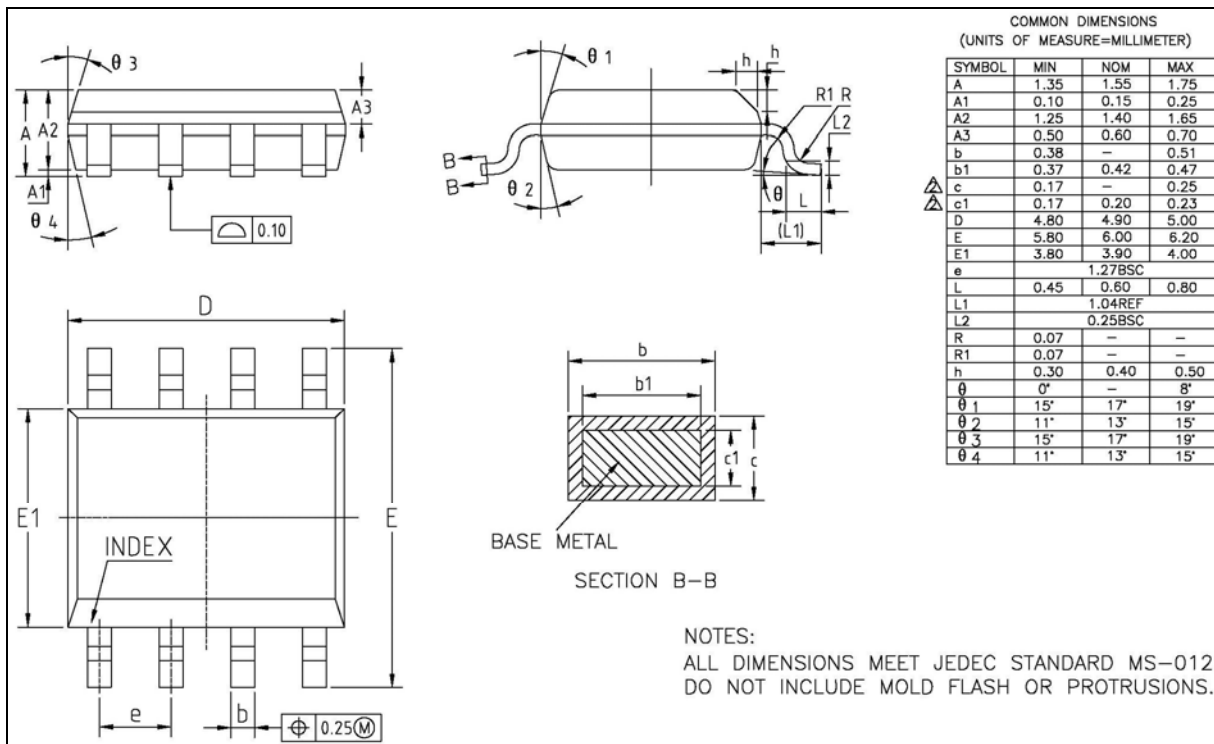

Customer Support

To share comments, get your technical questions answered, or report issues you may be experiencing with our products, please visit Zilog's Technical Support page at <http://support.zilog.com>.

To learn more about this product, find additional documentation, or to discover other facets about Zilog product offerings, please visit the [Zilog Knowledge Base](#) or consider participating in the [Zilog Forum](#).

This publication is subject to replacement by a later edition. To determine whether a later edition exists, please visit the Zilog website at <http://www.zilog.com>.