

DATA SHEET

SMV2019-SMV2023 Series: Hyperabrupt Junction Tuning Varactors

Applications

- Low phase noise VCOs in wireless systems
- RF and microwave VCOs and phase shifters

Features

- Low series resistance
- High capacitance ratio at low reverse voltage
- Packages rated MSL1, 260 °C per JEDEC J-STD-020



Skyworks Green™ products are RoHS (Restriction of Hazardous Substances)-compliant, conform to the EIA/EICTA/JEITA Joint Industry Guide (JIG) Level A guidelines, are halogen free according to IEC-61249-2-21, and contain <1,000 ppm antimony trioxide in polymeric materials.







Description

The SMV2019-SMV2023 series are silicon hyperabrupt junction varactor diodes. The capacitance ratio and low series resistance of these varactors make them attractive for low phase noise Voltage-Controlled Oscillators (VCOs) in wireless systems.

Table 1 describes the various packages and markings of the SMV2019-SMV2023 series of varactors.

Table 1. Packaging and Marking

			
Single	Common Cathode	Single	Single
SOT-23	SOT-23	SOD-323 Green™	SC-79 Green™
			SMV2019-079LF Marking: Cathode
	SMV2022-004 Marking: VJ3		SMV2020-079LF Marking: Cathode
	SMV2022-004LF Green™ Marking: DJ3		
SMV2023-001 Marking: VK1	SMV2023-004 Marking: VK3		
SMV2023-001LF Green™ Marking: DK1	SMV2023-004LF Green™ Marking: DK3	SMV2023-011LF Marking: DK1	
Ls = 1.5 nH	Ls = 1.5 nH	Ls = 1.5 nH	Ls = 0.7 nH



The Pb-free symbol or "LF" in the part number denotes a lead-free, RoHS-compliant package unless otherwise noted as Green™. Tin/lead (Sn/Pb) packaging is not recommended for new designs.

Table 2. SMV2019-SMV2023 Absolute Maximum Ratings

Parameter	Symbol	Minimum	Typical	Maximum	Units
Reverse voltage	V_R			22	V
Forward current	I_F			20	mA
Power dissipation	P_{DIS}			250	mW
Operating temperature	T_{OP}	-55		+125	°C
Storage temperature	T_{STG}	-55		+150	°C

Note: Exposure to maximum rating conditions for extended periods may reduce device reliability. There is no damage to device with only one parameter set at the limit and all other parameters set at or below their nominal value. Exceeding any of the limits listed here may result in permanent damage to the device.

CAUTION: Although this device is designed to be as robust as possible, Electrostatic Discharge (ESD) can damage this device. This device must be protected at all times from ESD. Static charges may easily produce potentials of several kilovolts on the human body or equipment, which can discharge without detection. Industry-standard ESD precautions should be used at all times. The SMV2019-SMV2023 series of varactors are Class 0 Human Body Model (HBM) ESD devices.

Table 3. SMV2019-SMV2023 Electrical Specifications (Note 1) (Note 2)
($T_{OP} = 25\text{ °C}$, Unless Otherwise Noted)

Part Number	$C_T @ 4\text{ V}$ (pF)		$C_T @ 20\text{ V}$ (pF)		$\frac{C_T @ 4\text{ V}}{C_T @ 20\text{ V}}$ Ratio	$Q @ 4\text{ V},$ 50 MHz
	Minimum	Maximum	Minimum	Maximum	Minimum	Typical
SMV2019	0.65	0.95	0.26	0.34	2.30	500
SMV2020	1.20	1.53	0.30	0.43	2.80	500
SMV2022	2.50	3.30	0.60	0.85	3.00	500
SMV2023	4.40	5.40	0.90	1.20	4.20	500

Note 1: Performance is guaranteed only under the conditions listed in this Table.

Note 2: Reverse current, I_R ($V_R = 16\text{ V}$): 50 nA maximum.

Electrical and Mechanical Specifications

The absolute maximum ratings of the SMV2019-SMV2023 series of varactors are provided in Table 2. Electrical specifications are provided in Table 3. The relationship between capacitance and reverse voltage is illustrated in Figures 1, 2, and 3. Table 4 summarizes the capacitance of the SMV2019-SMV2023 series.

The SPICE model for the SMV2019-SMV2023 varactor series is shown in Figure 4 and the associated model parameters are provided in Table 5.

Package dimensions are provided in Figures 5, 7, and 9, and tape and reel drawings are provided in Figures 6, 8, and 10.

Package and Handling Information

Instructions on the shipping container label regarding exposure to moisture after the container seal is broken must be followed. Otherwise, problems related to moisture absorption may occur when the part is subjected to high temperature during solder assembly.

The SMV2019-SMV2023 varactors are rated to Moisture Sensitivity Level 1 (MSL1) at 260 °C. They can be used for lead or lead-free soldering. For additional information, refer to the Skyworks Application Note, *Solder Reflow Information*, document number 200164.

Care must be taken when attaching this product, whether it is done manually or in a production solder reflow environment. Production quantities of this product are shipped in a standard tape and reel format.

Typical Performance Characteristics

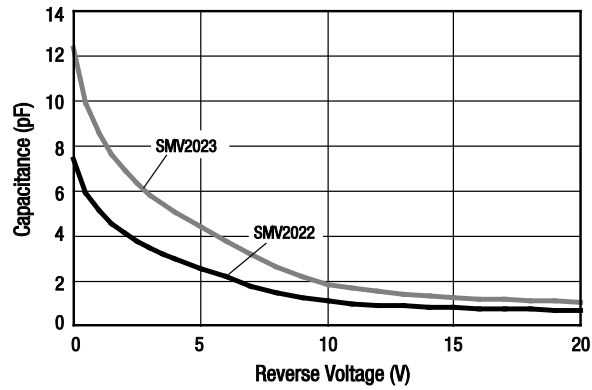

Figure 1. SMV2022 and SMV2023 Capacitance vs Reverse Voltage

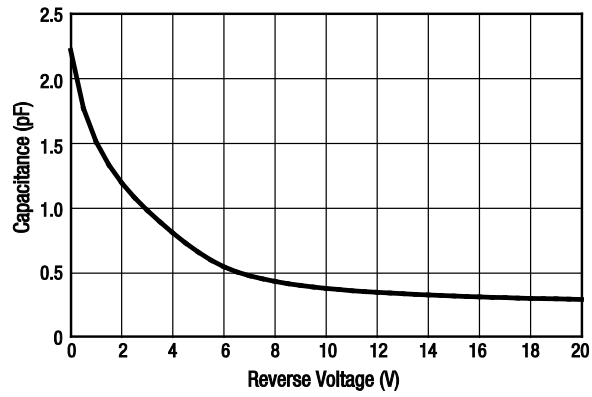

Figure 2. SMV2019-079LF Capacitance vs Reverse Voltage

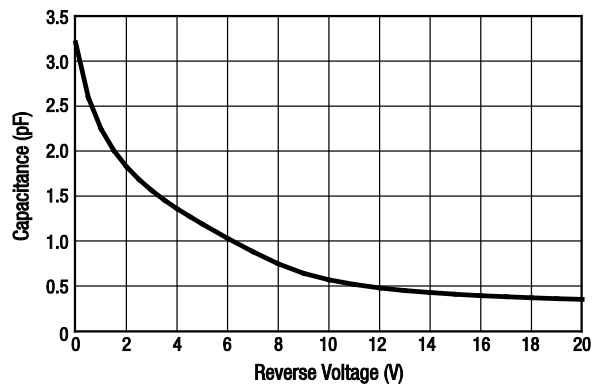

Figure 3. SMV2020-079LF Capacitance vs Reverse Voltage

Table 4. Capacitance vs Reverse Voltage

V _R (V)	C _T (pF)			
	SMV2019	SMV2020	SMV2022	SMV2023
0	2.22	3.20	7.41	12.33
0.5	1.77	2.59	5.94	9.90
1.0	1.51	2.25	5.14	8.60
1.5	1.33	2.01	4.56	7.62
2.0	1.20	1.83	4.14	6.94
2.5	1.08	1.68	3.78	6.34
3.0	0.98	1.56	3.49	5.88
3.5	0.89	1.46	3.23	5.45
4.0	0.81	1.36	3.01	5.09
5.0	0.66	1.19	2.54	4.42
6.0	0.55	1.03	2.18	3.77
7.0	0.48	0.88	1.80	3.18
8.0	0.44	0.75	1.50	2.63
9.0	0.40	0.64	1.29	2.21
10.0	0.38	0.57	1.11	1.86
11.0	0.37	0.52	1.03	1.68
12.0	0.35	0.48	0.96	1.54
13.0	0.34	0.45	0.91	1.44
14.0	0.33	0.43	0.87	1.37
15.0	0.32	0.41	0.83	1.30
16.0	0.32	0.39	0.81	1.25
17.0	0.31	0.38	0.78	1.20
18.0	0.31	0.37	0.76	1.16
19.0	0.30	0.36	0.75	1.13
20.0	0.30	0.35	0.73	1.09

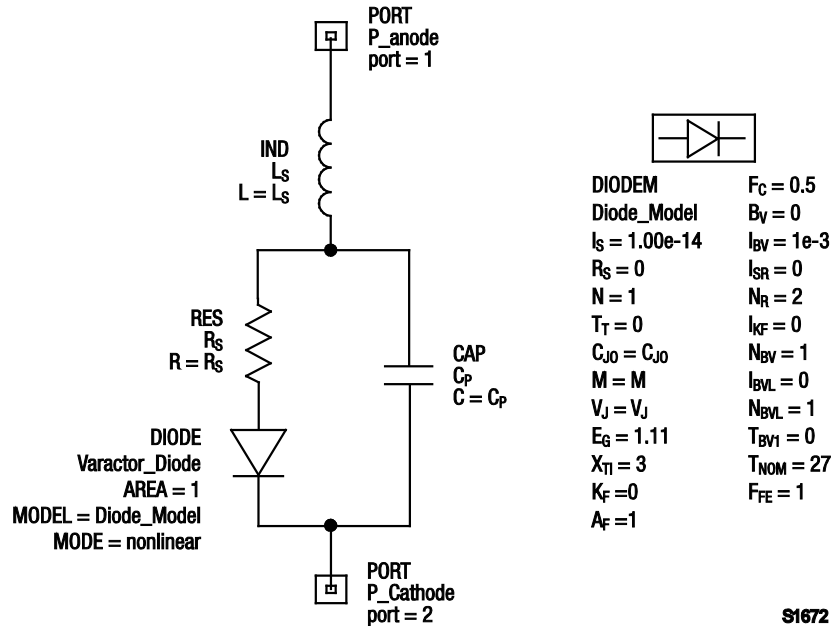
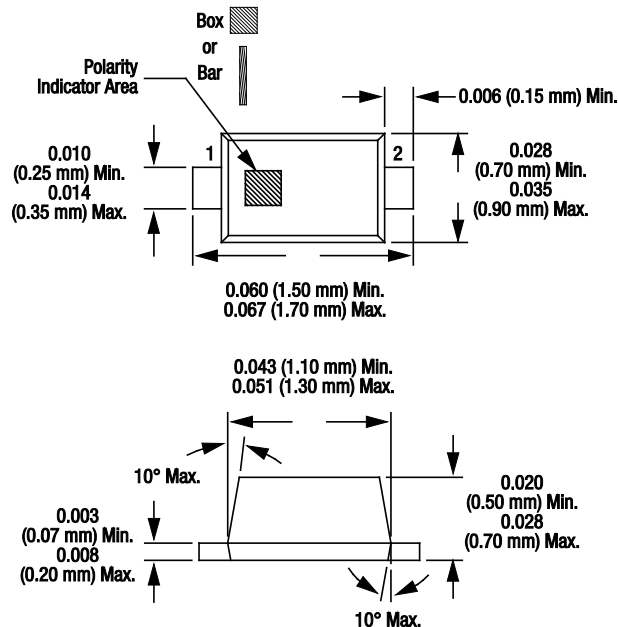

Figure 4. SPICE Model

Table 5. SPICE Model Parameters

Part Number	C _{J0} (pF)	V _J (V)	M	C _P (pF)	R _S (Ω)	L _S (nH)
SMV2019-079LF	2.25	3.5	1.4	0.07	4.8	0.7
SMV2020-079LF	3.20	4.4	1.45	0	2.5	0.7
SMV2022 series	7.30	4.0	1.4	0	2.2	1.5
SMV2023 series	12.23	4.0	1.4	0	1.6	1.5



Dimensions are in inches (millimeters shown in parentheses) S1652

Figure 5. SC-79 Package Dimensions

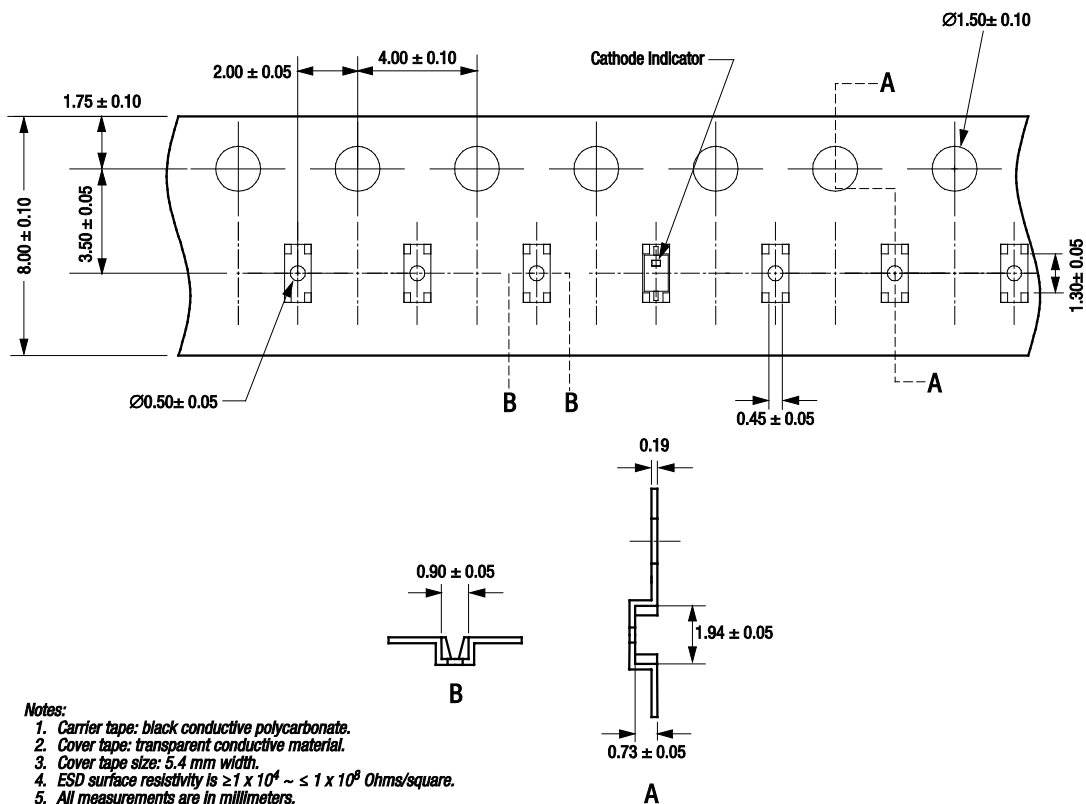

- Notes:
1. Carrier tape: black conductive polycarbonate.
 2. Cover tape: transparent conductive material.
 3. Cover tape size: 5.4 mm width.
 4. ESD surface resistivity is $\geq 1 \times 10^4 \sim \leq 1 \times 10^9$ Ohms/square.
 5. All measurements are in millimeters.
 6. Standard reel size is 7 inches. Standard reel quantity is 3000 pcs.

S2186

Figure 6. SC-79 Tape and Reel Dimensions

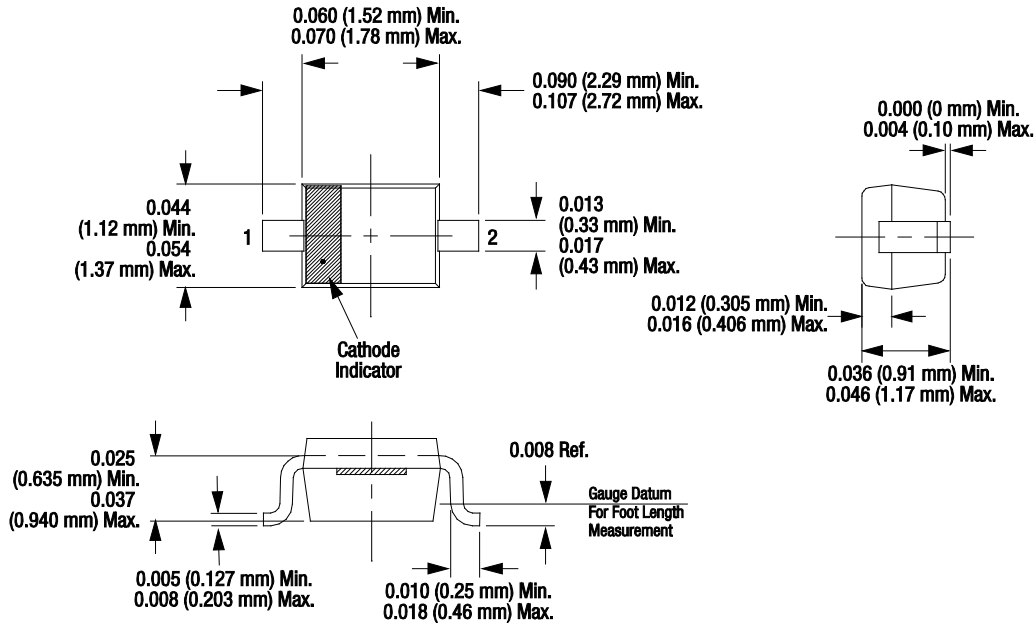

Dimensions are in inches (millimeters shown in parentheses)

S1619

Figure 7. SOD-323 Package Dimensions

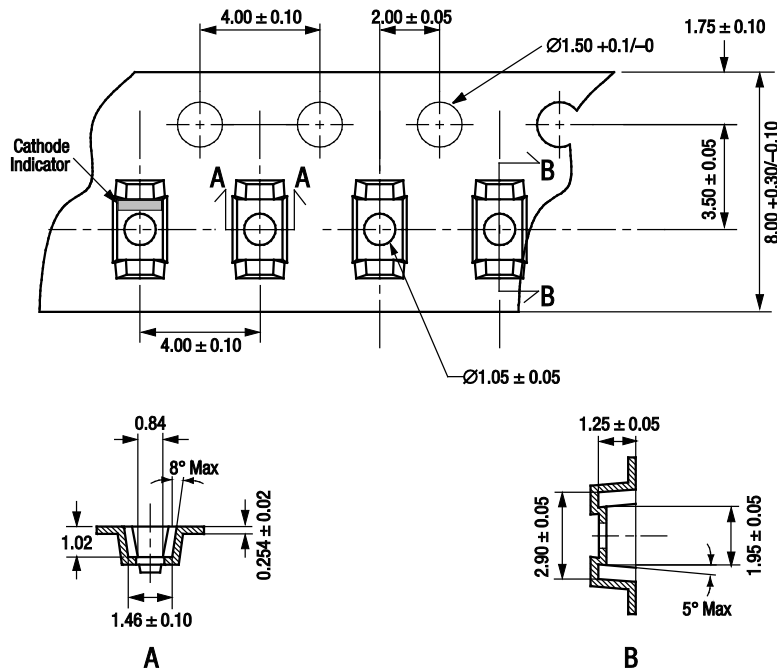

Notes:

1. Carrier tape: black conductive polycarbonate or polystyrene.
2. Cover tape: transparent conductive material.
3. Cover tape size: 5.5 mm width.
4. ESD surface resistivity is $\geq 1 \times 10^5 \sim \leq 1 \times 10^{11}$ Ohms/square.
5. 10 sprocket hole pitch cumulative tolerance: ± 0.20 mm.
6. A_o and B_o measured on plane 0.30 mm above bottom of the pocket.
7. All measurements are in millimeters.
8. Standard reel size is 7 inches. Standard reel quantity is 3000 pcs.

S2061

Figure 8. SOD-323 Tape and Reel Dimensions

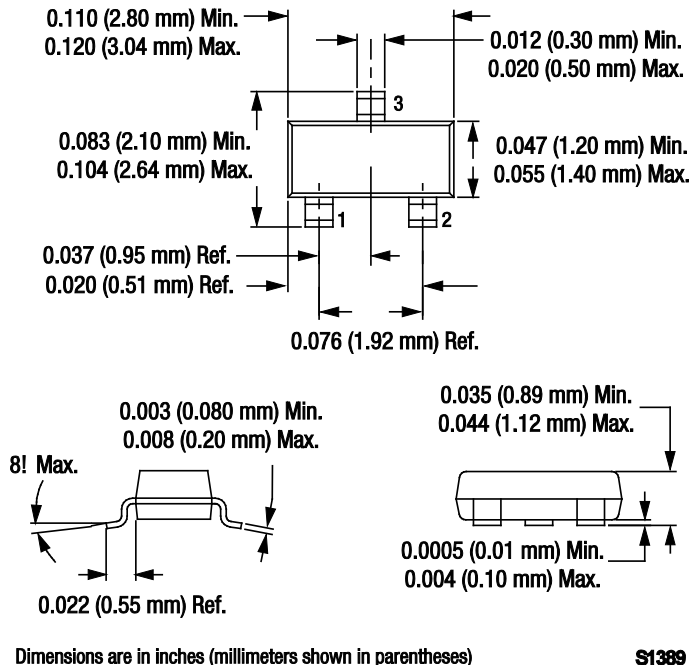

Figure 9. SOT-23 Package Dimensions

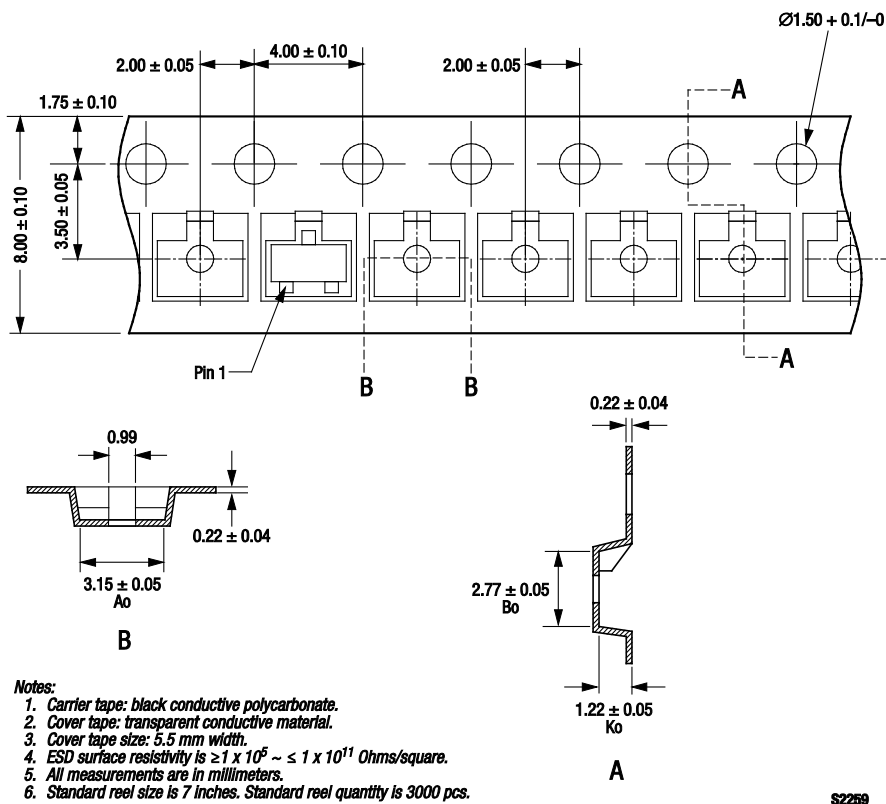

Figure 10. SOT-23 Tape and Reel Dimensions

Copyright © 2002-2007, 2009, 2010, 2011 Skyworks Solutions, Inc. All Rights Reserved.

Information in this document is provided in connection with Skyworks Solutions, Inc. ("Skyworks") products or services. These materials, including the information contained herein, are provided by Skyworks as a service to its customers and may be used for informational purposes only by the customer. Skyworks assumes no responsibility for errors or omissions in these materials or the information contained herein. Skyworks may change its documentation, products, services, specifications or product descriptions at any time, without notice. Skyworks makes no commitment to update the materials or information and shall have no responsibility whatsoever for conflicts, incompatibilities, or other difficulties arising from any future changes.

No license, whether express, implied, by estoppel or otherwise, is granted to any intellectual property rights by this document. Skyworks assumes no liability for any materials, products or information provided hereunder, including the sale, distribution, reproduction or use of Skyworks products, information or materials, except as may be provided in Skyworks Terms and Conditions of Sale.

THE MATERIALS, PRODUCTS AND INFORMATION ARE PROVIDED "AS IS" WITHOUT WARRANTY OF ANY KIND, WHETHER EXPRESS, IMPLIED, STATUTORY, OR OTHERWISE, INCLUDING FITNESS FOR A PARTICULAR PURPOSE OR USE, MERCHANTABILITY, PERFORMANCE, QUALITY OR NON-INFRINGEMENT OF ANY INTELLECTUAL PROPERTY RIGHT; ALL SUCH WARRANTIES ARE HEREBY EXPRESSLY DISCLAIMED. SKYWORKS DOES NOT WARRANT THE ACCURACY OR COMPLETENESS OF THE INFORMATION, TEXT, GRAPHICS OR OTHER ITEMS CONTAINED WITHIN THESE MATERIALS. SKYWORKS SHALL NOT BE LIABLE FOR ANY DAMAGES, INCLUDING BUT NOT LIMITED TO ANY SPECIAL, INDIRECT, INCIDENTAL, STATUTORY, OR CONSEQUENTIAL DAMAGES, INCLUDING WITHOUT LIMITATION, LOST REVENUES OR LOST PROFITS THAT MAY RESULT FROM THE USE OF THE MATERIALS OR INFORMATION, WHETHER OR NOT THE RECIPIENT OF MATERIALS HAS BEEN ADVISED OF THE POSSIBILITY OF SUCH DAMAGE.

Skyworks products are not intended for use in medical, lifesaving or life-sustaining applications, or other equipment in which the failure of the Skyworks products could lead to personal injury, death, physical or environmental damage. Skyworks customers using or selling Skyworks products for use in such applications do so at their own risk and agree to fully indemnify Skyworks for any damages resulting from such improper use or sale.

Customers are responsible for their products and applications using Skyworks products, which may deviate from published specifications as a result of design defects, errors, or operation of products outside of published parameters or design specifications. Customers should include design and operating safeguards to minimize these and other risks. Skyworks assumes no liability for applications assistance, customer product design, or damage to any equipment resulting from the use of Skyworks products outside of stated published specifications or parameters.

Skyworks, the Skyworks symbol, and "Breakthrough Simplicity" are trademarks or registered trademarks of Skyworks Solutions, Inc., in the United States and other countries. Third-party brands and names are for identification purposes only, and are the property of their respective owners. Additional information, including relevant terms and conditions, posted at www.skyworksinc.com, are incorporated by reference.