

PolarHV™ HiPerFET IXFC 22N60P

Power MOSFET

ISOPLUS220™

(Electrically Isolated Back Surface)

N-Channel Enhancement Mode
Fast Intrinsic Diode
Avalanche Rated

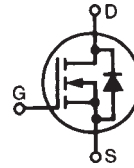

$V_{DSS} = 600 \text{ V}$
 $I_{D25} = 12 \text{ A}$
 $R_{DS(on)} \leq 360 \text{ m}\Omega$
 $t_{rr} \leq 200 \text{ ns}$

| Symbol | Test Conditions | Maximum Ratings | |
|---------------|---|-----------------|------------------|
| V_{DSS} | $T_J = 25^\circ\text{C}$ to 150°C | 600 | V |
| V_{DGR} | $T_J = 25^\circ\text{C}$ to 150°C ; $R_{GS} = 1 \text{ M}\Omega$ | 600 | V |
| V_{GS} | Continuous | ± 30 | V |
| V_{GSM} | Transient | ± 40 | V |
| I_{D25} | $T_C = 25^\circ\text{C}$ | 12 | A |
| I_{DM} | $T_C = 25^\circ\text{C}$, pulse width limited by T_{JM} | 66 | A |
| I_{AR} | $T_C = 25^\circ\text{C}$ | 22 | A |
| E_{AR} | $T_C = 25^\circ\text{C}$ | 40 | mJ |
| E_{AS} | $T_C = 25^\circ\text{C}$ | 1.0 | J |
| dv/dt | $I_S \leq I_{DM}$, $di/dt \leq 100 \text{ A}/\mu\text{s}$, $V_{DD} \leq V_{DSS}$ $T_J \leq 150^\circ\text{C}$, $R_G = 4 \Omega$ | 10 | V/ns |
| P_D | $T_C = 25^\circ\text{C}$ | 130 | W |
| T_J | | -55 ... +150 | $^\circ\text{C}$ |
| T_{JM} | | 150 | $^\circ\text{C}$ |
| T_{stg} | | -55 ... +150 | $^\circ\text{C}$ |
| T_L | 1.6 mm (0.062 in.) from case for 10 s | 300 | $^\circ\text{C}$ |
| V_{ISOL} | 50/60 Hz, RMS $t = 1$ minute leads-to-tab | 2500 | V~ |
| F_C | Mounting Force | 11..65/2.5..15 | N/lb |
| Weight | | 2 | g |

ISOPLUS220™ (IXFC)
E153432

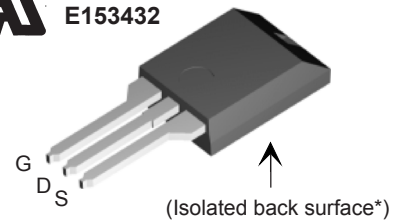

G = Gate
S = Source
D = Drain

Features

- † Silicon chip on Direct-Copper-Bond substrate
- High power dissipation
- Isolated mounting surface
- 2500V electrical isolation
- † Low drain to tab capacitance (<35pF)
- † Low $R_{DS(on)}$ HDMOS™ process
- † Rugged polysilicon gate cell structure
- † Unclamped Inductive Switching (UIS) rated
- † Fast intrinsic Rectifier

Applications

- † DC-DC converters
- † Battery chargers
- † Switched-mode and resonant-mode power supplies
- † DC choppers
- † AC motor control

Advantages

- † Easy assembly: no screws, or isolation foils required
- † Space savings
- † High power density
- † Low collector capacitance to ground (low EMI)

| Symbol | Test Conditions ($T_J = 25^\circ\text{C}$ unless otherwise specified) | Characteristic Values | | |
|--------------|---|-----------------------|------|---------------------------------------|
| | | Min. | Typ. | Max. |
| BV_{DSS} | $V_{GS} = 0 \text{ V}$, $I_D = 250 \mu\text{A}$ | 600 | | V |
| $V_{GS(th)}$ | $V_{DS} = V_{GS}$, $I_D = 4 \text{ mA}$ | 3.0 | | 5.0 V |
| I_{GSS} | $V_{GS} = \pm 30 \text{ V}_{DC}$, $V_{DS} = 0$ | | | $\pm 100 \text{ nA}$ |
| I_{DSS} | $V_{DS} = V_{DSS}$ $V_{GS} = 0 \text{ V}$ $T_J = 125^\circ\text{C}$ | | | 25 μA 250 μA |
| $R_{DS(on)}$ | $V_{GS} = 10 \text{ V}$, $I_D = I_T$, Note 1 | | | 360 $\text{m}\Omega$ |

| Symbol | Test Conditions | Characteristic Values ($T_J = 25^\circ\text{C}$ unless otherwise specified) | | |
|--------------|---|---|------|--------------------|
| | | Min. | Typ. | Max. |
| g_{fs} | $V_{DS} = 20\text{ V}; I_D = I_T$, Note 1 | 13 | 20 | S |
| C_{iss} | $V_{GS} = 0\text{ V}, V_{DS} = 25\text{ V}, f = 1\text{ MHz}$ | | 4000 | pF |
| C_{oss} | | | 320 | pF |
| C_{rss} | | | 22 | pF |
| $t_{d(on)}$ | $V_{GS} = 10\text{ V}, V_{DS} = 0.5 V_{DSS}, I_D = I_T$ $R_G = 4\ \Omega$ (External) | | 20 | ns |
| t_r | | | 20 | ns |
| $t_{d(off)}$ | | | 60 | ns |
| t_f | | | 23 | ns |
| $Q_{g(on)}$ | $V_{GS} = 10\text{ V}, V_{DS} = 0.5 V_{DSS}, I_D = I_T$ | | 58 | nC |
| Q_{gs} | | | 23 | nC |
| Q_{gd} | | | 20 | nC |
| R_{thJC} | | | 0.95 | $^\circ\text{C/W}$ |
| R_{thCS} | | 0.21 | | $^\circ\text{C/W}$ |

Source-Drain Diode

| Symbol | Test Conditions | Characteristic Values ($T_J = 25^\circ\text{C}$ unless otherwise specified) | | |
|----------|--|---|------|---|
| | | Min. | Typ. | Max. |
| I_S | $V_{GS} = 0\text{ V}$ | | | 12 A |
| I_{SM} | Repetitive | | | 66 A |
| V_{SD} | $I_F = I_S, V_{GS} = 0\text{ V}$, | | | 1.5 V |
| t_{rr} | $I_F = 25\text{ A}, -di/dt = 100\text{ A}/\mu\text{s}$ | | | 200 ns |
| Q_{RM} | | | | $V_R = 100\text{ V}, V_{GS} = 0\text{ V}$ |

Notes:

1. Pulse test, $t \leq 300\ \mu\text{s}$, duty cycle $d \leq 2\%$;
2. Test current $I_T = 11\text{ A}$.

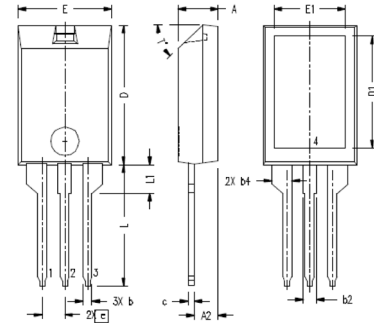
ISOPLUS220™ (IXFC) Outline

Note:
Bottom heatsink (Pin 4) is electrically isolated from Pin 1, 2, or 3.

| SYM | INCHES | | MILLIMETERS | |
|-----|------------|------|-------------|-------|
| | MIN | MAX | MIN | MAX |
| A | .157 | .197 | 4.00 | 5.00 |
| A2 | .098 | .118 | 2.50 | 3.00 |
| b | .035 | .051 | 0.90 | 1.30 |
| b2 | .049 | .065 | 1.25 | 1.65 |
| b4 | .093 | .100 | 2.35 | 2.55 |
| c | .028 | .039 | 0.70 | 1.00 |
| D | .591 | .630 | 15.00 | 16.00 |
| D1 | .472 | .512 | 12.00 | 13.00 |
| E | .394 | .433 | 10.00 | 11.00 |
| E1 | .295 | .335 | 7.50 | 8.50 |
| e | .100 BASIC | | 2.55 BASIC | |
| L | .512 | .571 | 13.00 | 14.50 |
| L1 | .118 | .138 | 3.00 | 3.50 |
| T* | | | 42.5° | 47.5° |

Ref: IXYS CO 0177 R0

**Fig. 1. Output Characteristics
@ 25°C**

**Fig. 2. Extended Output Characteristics
@ 25°C**

**Fig. 3. Output Characteristics
@ 125°C**

**Fig. 4. $R_{DS(on)}$ Normalized to $I_D = 11A$
Value vs. Junction Temperature**

**Fig. 5. $R_{DS(on)}$ Normalized to
 $I_D = 11A$ Value vs. Drain Current**

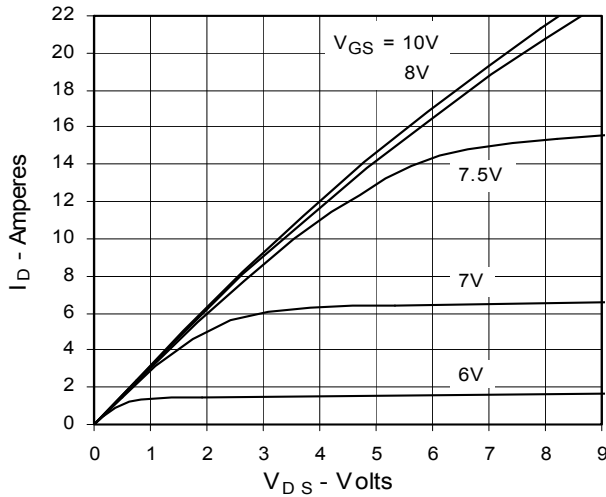
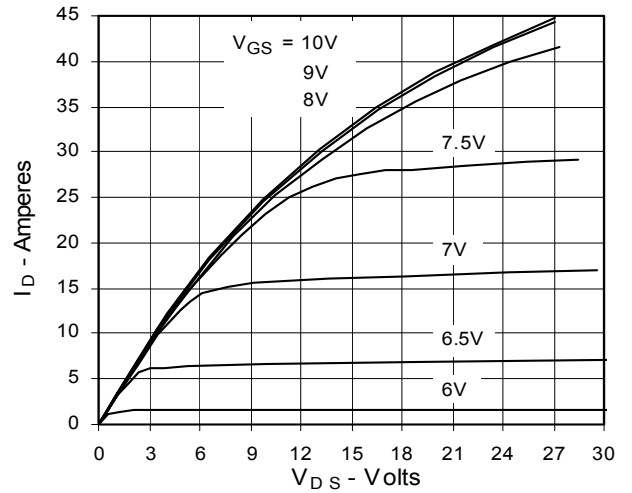
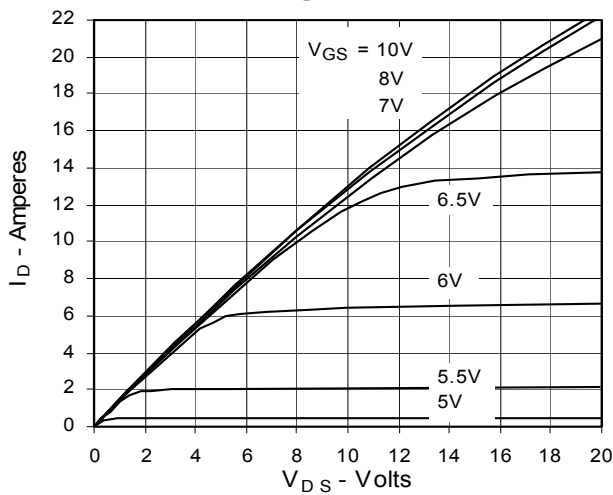
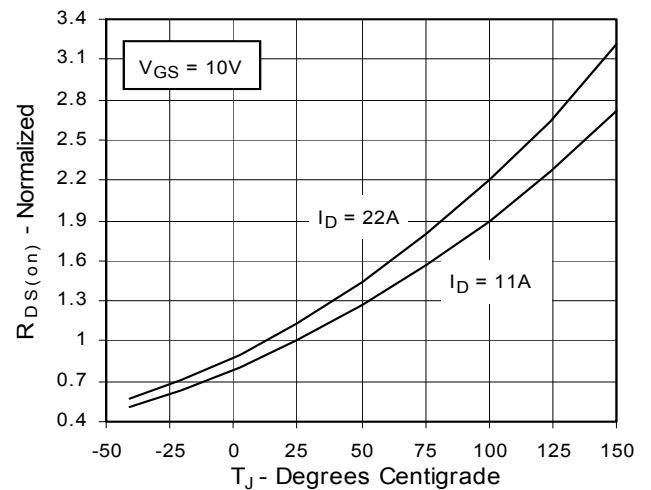
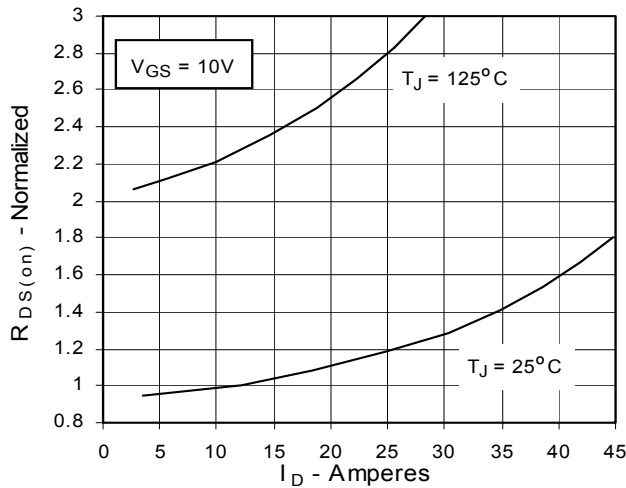
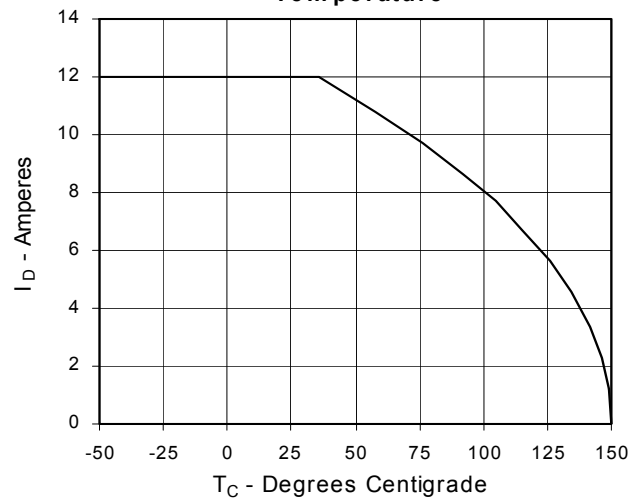
**Fig. 6. Drain Current vs. Case
Temperature**

Fig. 7. Input Admittance

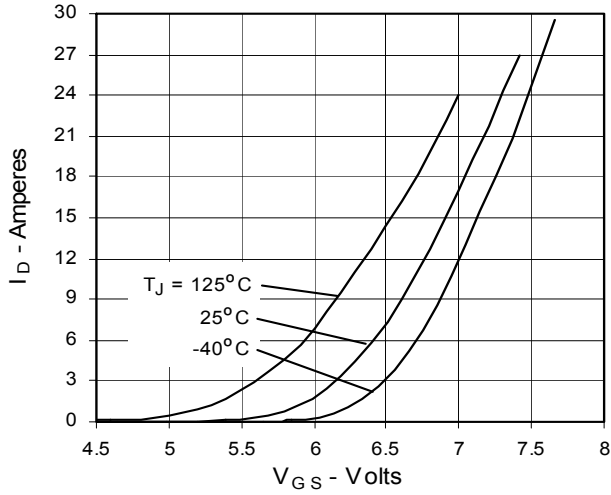

Fig. 8. Transconductance

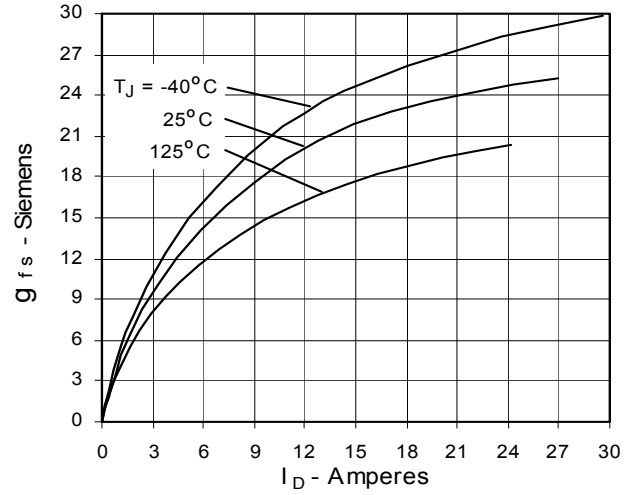

Fig. 9. Source Current vs. Source-To-Drain Voltage

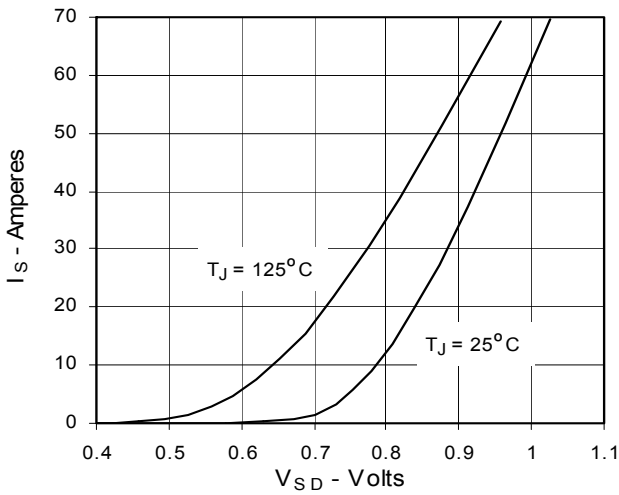

Fig. 10. Gate Charge

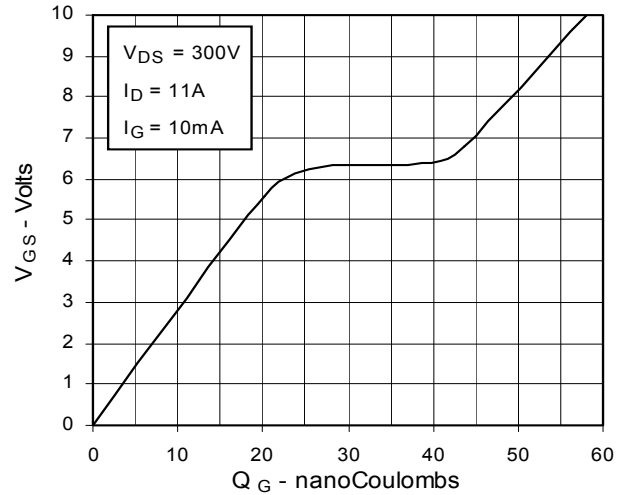

Fig. 11. Capacitance

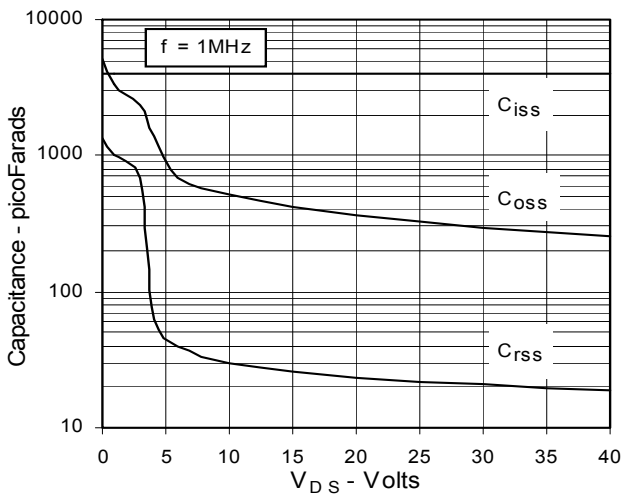

Fig. 12. Forward-Bias Safe Operating Area

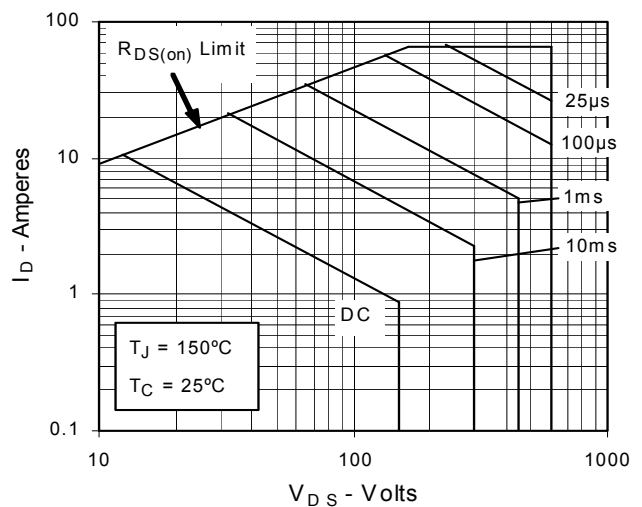

Fig. 13. Maximum Transient Thermal Resistance

