

DATA SHEET

SMV1705 Hyperabrupt Tuning Varactors Supplied on Film Frame and Waffle Packs

Applications

- Wide bandwidth VCOs
- VHF and UHF TV tuners
- Analog phase shifters

Features

- Designed for high volume, low-cost battery applications
- Low series resistance
- High capacitance ratio
- Available as:
 - Full wafer on film frame (SMV1705-099)
 - Dice in waffle packs (SMV1705-000)
- Small footprint chip size: 12 x 12 x 5.5 mils



Description

Skyworks SMV1705 varactors are silicon hyperabrupt junction varactor diodes specifically designed for battery operation. These devices have a high capacitance ratio and low series resistance, which makes them appropriate for low phase noise Voltage Controlled Oscillators (VCOs) operating at wireless frequencies of 2.5 GHz and higher.

The SMV1705-099 is supplied as 100 percent electrically tested, fully singulated wafers mounted on a film frame. The SMV1705-000 is supplied as a 100 percent electrically tested die in waffle packs.

The absolute maximum ratings of the SMV1705 varactors are provided in Table 1. Electrical specifications are specified in Table 2. Typical performance characteristics are provided in Figures 1 and 2. The SPICE model for the SMV1705 die is shown in Figure 3 and the associated model parameters are provided in Table 3. Die mechanical characteristics are listed in Table 4.

NEW



Skyworks Green™ products are RoHS (Restriction of Hazardous Substances)-compliant, conform to the EIA/EICTA/JEITA Joint Industry Guide (JIG) Level A guidelines, are halogen free according to IEC-61249-2-21, and contain <1,000 ppm antimony trioxide in polymeric materials.

Table 1. SMV1705-000/-099 Absolute Maximum Ratings

Parameter	Symbol	Minimum	Typical	Maximum	Units
Power dissipation (@ cathode temperature of 25 °C)	P _{DIS}			250	mW
Reverse voltage	V _R			12	V
Forward current	I _F			20	mA
Junction temperature	T _J	-55		+150	°C
Storage temperature	T _{STG}	-55		+150	°C

Note: Exposure to maximum rating conditions for extended periods may reduce device reliability. There is no damage to device with only one parameter set at the limit and all other parameters set at or below their nominal value. Exceeding any of the limits listed here may result in permanent damage to the device.

CAUTION: Although this device is designed to be as robust as possible, Electrostatic Discharge (ESD) can damage this device. This device must be protected at all times from ESD. Static charges may easily produce potentials of several kilovolts on the human body or equipment, which can discharge without detection. Industry-standard ESD precautions should be used at all times.

Table 2. SMV1705-000/-099 Electrical Specifications (Note 1) (Note 2)
(Cathode Temperature = 25 °C, Unless Otherwise Noted)

Parameter	Symbol	Test Condition	Min	Typical	Max	Units
Reverse breakdown voltage	V _{BR}	I _R = 10 μA	12			V
Reverse leakage current	I _R	V _R = 8 V			20	nA
Junction capacitance	C _{J1}	V _R = 1 V, f = 1 MHz	17.3	18.3	19.3	pF
	C _{J4}	V _R = 4 V, f = 1 MHz	5.3	6.1	6.6	pF
Capacitance ratio	C _{J1} /C _{J4}		2.8	3.0		-
Series resistance	R _S	V _R = 1 V, f = 470 MHz		0.32		Ω

Note 1: Performance is guaranteed only under the conditions listed in this Table and is not guaranteed over the full operating or storage temperature ranges. Operation at elevated temperatures may reduce reliability of the device.

Note 2: The SMV1705-000 and SMV1705-099 are 100% tested for junction capacitance, capacitance ratio, reverse leakage current, and breakdown voltage. Electrical rejects of the SMV1705-099 devices (singulated wafer on film frame) are identified with black ink.

Typical Performance Characteristics

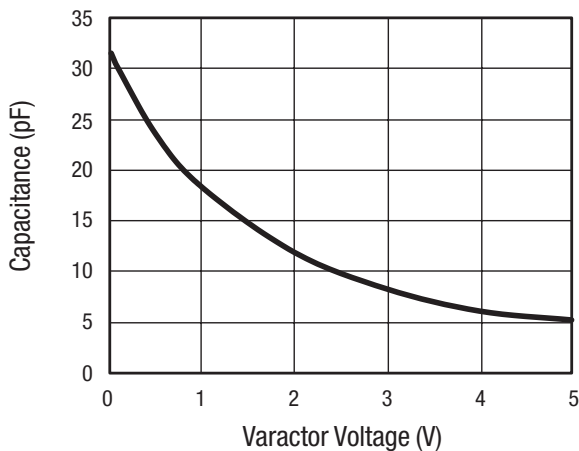

Figure 1. Capacitance vs Voltage
(T_J = 25 °C)

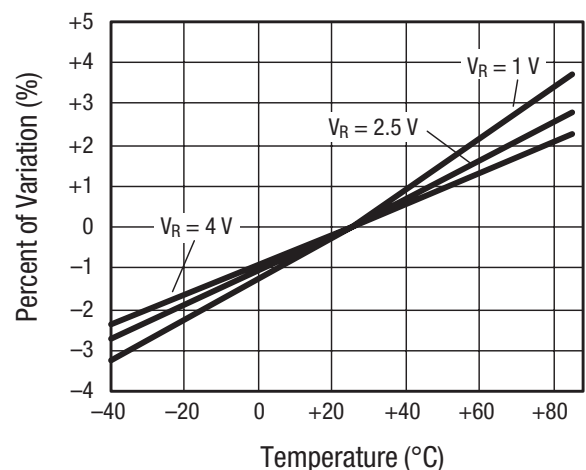

Figure 2. Relative Capacitance Change vs Temperature

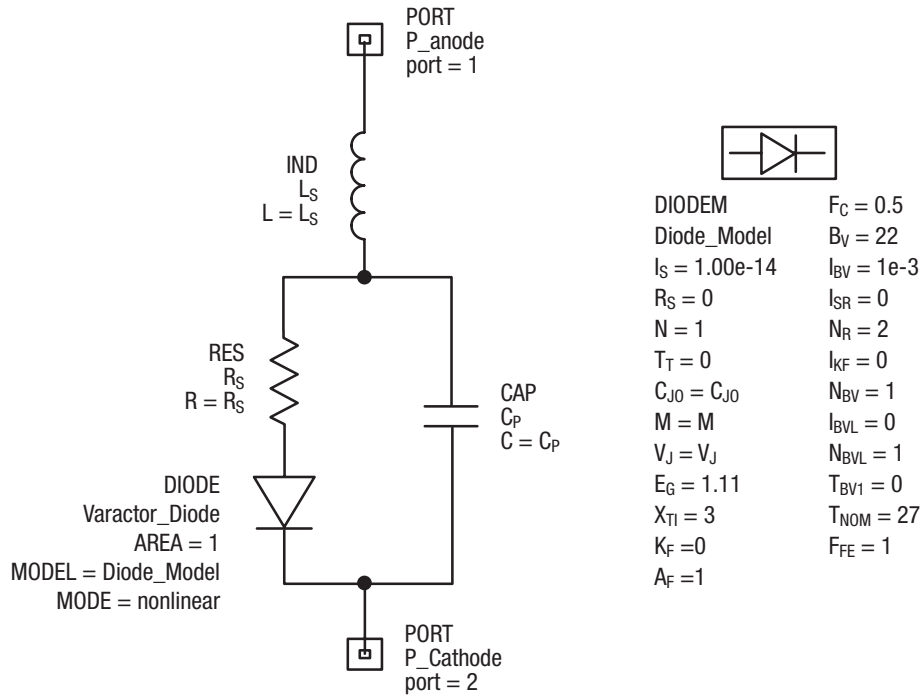

Figure 3. SPICE Model

Table 3. SPICE Model Parameters

Part Number	C _{J0} (pF)	V _J (V)	M	C _P (pF)	R _S (Ω)	L _S (nH)
SMV1705-000	31	3	2	0	0.32	0.15
SMV1705-099	31	3	2	0	0.32	0.15

Table 4. SMV1705 Die Characteristics

Part Number	Typical Quantity of Good Dice Per Wafer	Chip Size		Chip Thickness		Typical Anode Contact Diameter	
		(in)	(mm)	(in)	(mm)	(in)	(mm)
SMV1705-000	N/A	0.012 x 0.012	0.3048 x 0.3048	0.0055 ± 0.0005	0.1397 ± 0.0127	0.00675	0.17145
SMV1705-099	60,000	0.012 x 0.012	0.3048 x 0.3048	0.0055 ± 0.0005	0.1397 ± 0.0127	0.00675	0.17145

Package Outline Drawings

Table 4 identifies the die part numbers with their corresponding quantity per wafer and chip measurements. The package outline die drawing for the SMV1705-000 (dice in wafer packs) is shown

in Figure 4. The package outline die drawing for the SMV1705-099 (full wafer on film frame) is shown in Figure 5.

The SMV1705-000 is supplied in quantities of 100 pieces per wafer pack.

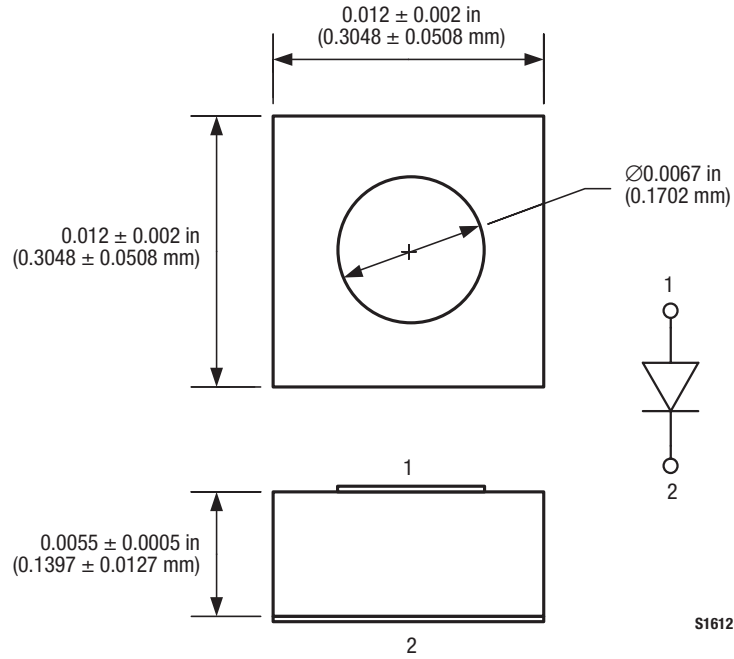

**Figure 4. SMV1705-000 Die Outline Drawing
(Dice in Waffle Packs)**

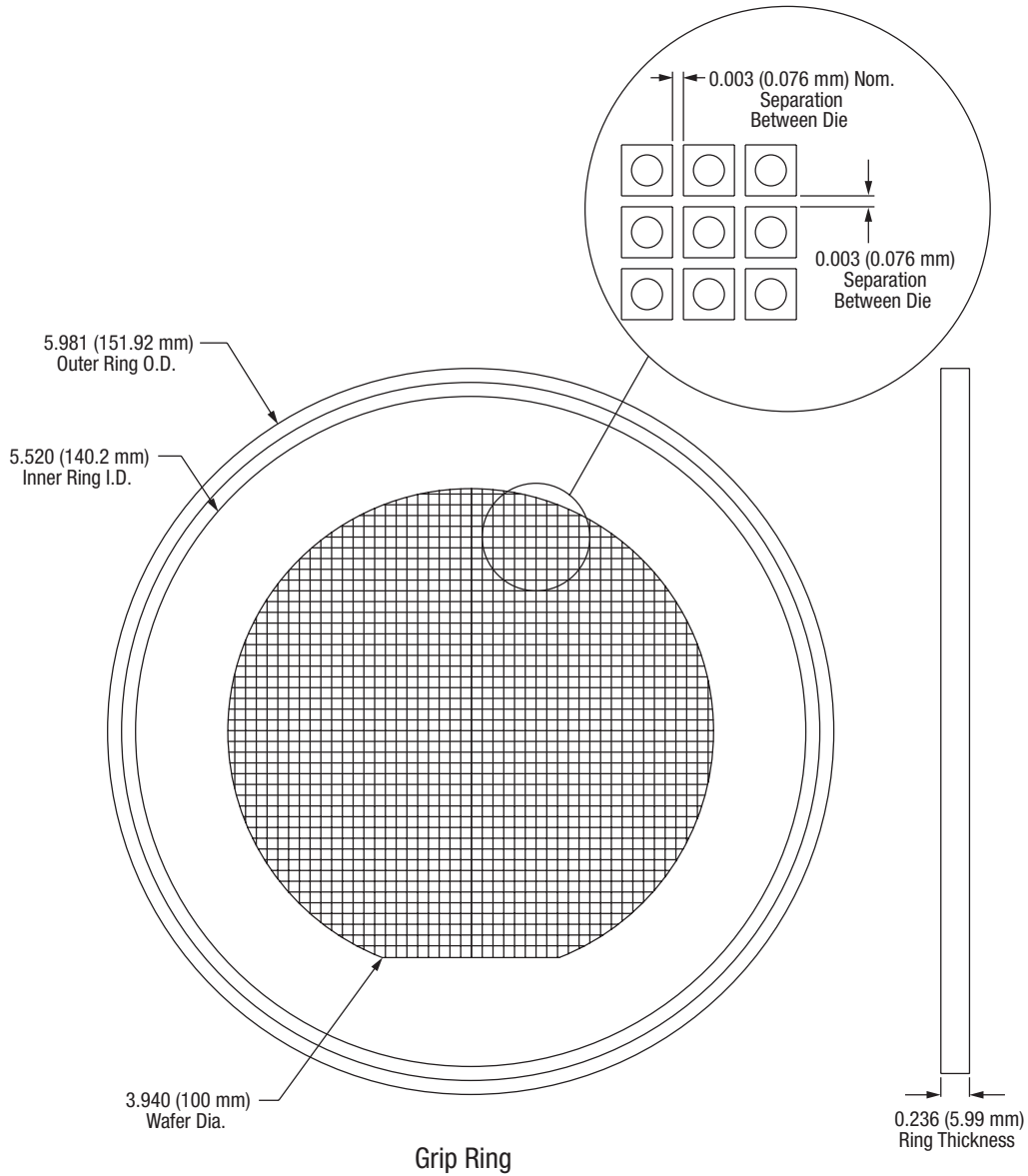

Wafer Film Frame Description
 Wafer on nitto tape
 Color: light blue
 Thickness: 2.2–3 mils
 Tensile strength: 6.6 (lbs. in width)
 Ring material: plastic

S1611

**Figure 5. SMV1705-099 Die Outline Drawing
 (Full Wafer on Film Frame)**

Ordering Information

Model Name	Manufacturing Part Number
SMV1705-000 (dice, 100 per wafer pack)	SMV1705-000
SMV1705-099 (singulated wafer on film frame)	SMV1705-099

Copyright © 2009 Skyworks Solutions, Inc. All Rights Reserved.

Information in this document is provided in connection with Skyworks Solutions, Inc. ("Skyworks") products or services. These materials, including the information contained herein, are provided by Skyworks as a service to its customers and may be used for informational purposes only by the customer. Skyworks assumes no responsibility for errors or omissions in these materials or the information contained herein. Skyworks may change its documentation, products, services, specifications or product descriptions at any time, without notice. Skyworks makes no commitment to update the materials or information and shall have no responsibility whatsoever for conflicts, incompatibilities, or other difficulties arising from any future changes.

No license, whether express, implied, by estoppel or otherwise, is granted to any intellectual property rights by this document. Skyworks assumes no liability for any materials, products or information provided hereunder, including the sale, distribution, reproduction or use of Skyworks products, information or materials, except as may be provided in Skyworks Terms and Conditions of Sale.

THE MATERIALS, PRODUCTS AND INFORMATION ARE PROVIDED "AS IS" WITHOUT WARRANTY OF ANY KIND, WHETHER EXPRESS, IMPLIED, STATUTORY, OR OTHERWISE, INCLUDING FITNESS FOR A PARTICULAR PURPOSE OR USE, MERCHANTABILITY, PERFORMANCE, QUALITY OR NON-INFRINGEMENT OF ANY INTELLECTUAL PROPERTY RIGHT; ALL SUCH WARRANTIES ARE HEREBY EXPRESSLY DISCLAIMED. SKYWORKS DOES NOT WARRANT THE ACCURACY OR COMPLETENESS OF THE INFORMATION, TEXT, GRAPHICS OR OTHER ITEMS CONTAINED WITHIN THESE MATERIALS. SKYWORKS SHALL NOT BE LIABLE FOR ANY DAMAGES, INCLUDING BUT NOT LIMITED TO ANY SPECIAL, INDIRECT, INCIDENTAL, STATUTORY, OR CONSEQUENTIAL DAMAGES, INCLUDING WITHOUT LIMITATION, LOST REVENUES OR LOST PROFITS THAT MAY RESULT FROM THE USE OF THE MATERIALS OR INFORMATION, WHETHER OR NOT THE RECIPIENT OF MATERIALS HAS BEEN ADVISED OF THE POSSIBILITY OF SUCH DAMAGE.

Skyworks products are not intended for use in medical, lifesaving or life-sustaining applications, or other equipment in which the failure of the Skyworks products could lead to personal injury, death, physical or environmental damage. Skyworks customers using or selling Skyworks products for use in such applications do so at their own risk and agree to fully indemnify Skyworks for any damages resulting from such improper use or sale.

Customers are responsible for their products and applications using Skyworks products, which may deviate from published specifications as a result of design defects, errors, or operation of products outside of published parameters or design specifications. Customers should include design and operating safeguards to minimize these and other risks. Skyworks assumes no liability for applications assistance, customer product design, or damage to any equipment resulting from the use of Skyworks products outside of stated published specifications or parameters.

Skyworks, the Skyworks symbol, and "Breakthrough Simplicity" are trademarks or registered trademarks of Skyworks Solutions, Inc., in the United States and other countries. Third-party brands and names are for identification purposes only, and are the property of their respective owners. Additional information, including relevant terms and conditions, posted at www.skyworksinc.com, are incorporated by reference.