

# Polar™ P & N-Channel Power MOSFET Common Drain Topology

## FMP26-02P

(Electrically Isolated Tab)

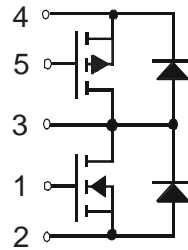

	P CH.	N CH.
$V_{DSS}$	- 200V	200V
$I_{D25}$	- 17A	26A
$R_{DS(on)}$	170mΩ	60mΩ
$t_{rr(typ)}$	240ns	150ns

Symbol	Test Conditions	Maximum Ratings	
$T_J$		-55 ... +150	°C
$T_{JM}$		150	°C
$T_{stg}$		-55 ... +150	°C
$V_{ISOLD}$	50/60Hz, RMS, t = 1min, Leads-to-Tab	2500	~V
$T_L$	1.6mm (0.062 in.) from Case for 10s	300	°C
$T_{SOLD}$	Plastic Body for 10s	260	°C
$F_C$	Mounting Force	20..120 / 4.5..27	N/lb.

Symbol	Test Conditions	Characteristic Values		
		Min.	Typ.	Max.
$C_P$	Coupling Capacitance Between Shorted Pins and Mounting Tab in the Case		40	pF
$d_S, d_A$	Pin - Pin	1.7		mm
$d_S, d_A$	Pin - Backside Metal	5.5		mm
Weight			9	g

### P - CHANNEL

Symbol	Test Conditions	Maximum Ratings	
$V_{DSS}$	$T_J = 25^{\circ}\text{C}$ to $150^{\circ}\text{C}$	- 200	V
$V_{DGR}$	$T_J = 25^{\circ}\text{C}$ to $150^{\circ}\text{C}$ , $R_{GS} = 1\text{M}\Omega$	- 200	V
$V_{GSS}$	Continuous	$\pm 20$	V
$V_{GSM}$	Transient	$\pm 30$	V
$I_{D25}$	$T_C = 25^{\circ}\text{C}$	-17	A
$I_{DM}$	$T_C = 25^{\circ}\text{C}$ , Pulse Width Limited by $T_{JM}$	- 70	A
$I_A$	$T_C = 25^{\circ}\text{C}$	- 26	A
$E_{AS}$	$T_C = 25^{\circ}\text{C}$	1.5	J
$P_D$	$T_C = 25^{\circ}\text{C}$	125	W

### ISOPLUS i4-Pak™

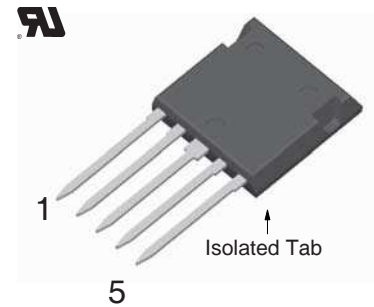

#### Features

- Silicon Chip on Direct-Copper Bond (DCB) Substrate
  - UL Recognized Package
  - Isolated Mounting Surface
  - 2500V~ Electrical Isolation
- Avalanche Rated
- Low  $Q_G$
- Low Drain-to-Tab Capacitance
- Low Package Inductance

#### Advantages

- Low Gate Drive Requirement
- High Power Density
- Low Drain to Ground Capacitance
- Fast Switching

#### Applications

- DC and AC Motor Drives
- Class AB Audio Amplifiers
- Multi-Phase DC to DC Converters
- Industrial Battery Chargers
- Switching Power Supplies

Symbol	Test Conditions ( $T_J = 25^\circ\text{C}$ Unless Otherwise Specified)	Characteristic Values		
		Min.	Typ.	Max.
$BV_{DSS}$	$V_{GS} = 0V, I_D = -250\mu\text{A}$	-200		V
$V_{GS(th)}$	$V_{DS} = V_{GS}, I_D = -250\mu\text{A}$	-2.5		V
$I_{GSS}$	$V_{GS} = \pm 20V, V_{DS} = 0V$			$\pm 100$ nA
$I_{DSS}$	$V_{DS} = V_{DSS}, V_{GS} = 0V$ $T_J = 125^\circ\text{C}$			-10 $\mu\text{A}$ -150 $\mu\text{A}$
$R_{DS(on)}$	$V_{GS} = -10V, I_D = -13A$ , Note 1			170 m $\Omega$
$g_{fs}$	$V_{DS} = -10V, I_D = -13A$ , Note 1	10	17	S
$C_{iss}$	$V_{GS} = 0V, V_{DS} = -25V, f = 1\text{MHz}$		2740	pF
$C_{oss}$				
$C_{rss}$				
$t_{d(on)}$	<b>Resistive Switching Times</b> $V_{GS} = -10V, V_{DS} = 0.5 \cdot V_{DSS}, I_D = -13A$ $R_G = 3.3\Omega$ (External)		18	ns
$t_r$				
$t_{d(off)}$				
$t_f$				
$Q_{g(on)}$	$V_{GS} = -10V, V_{DS} = 0.5 \cdot V_{DSS}, I_D = -13A$		56	nC
$Q_{gs}$				
$Q_{gd}$				
$R_{thJC}$				1.0 $^\circ\text{C/W}$
$R_{thCS}$		0.15		$^\circ\text{C/W}$

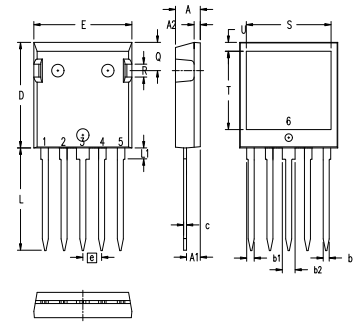
**ISOPLUS i4-Pak™ Outline**

NOTE: Bottom heatsink meets 3000 Volts AC 1 sec isolation to the other pins.

SYM	INCHES		MILLIMETERS	
	MIN	MAX	MIN	MAX
A	.190	.205	4.83	5.21
A1	.102	.118	2.59	3.00
A2	.046	.085	1.17	2.16
b	.045	.055	1.14	1.40
b1	.058	.068	1.47	1.73
b2	.100	.110	2.54	2.79
C	.020	.029	0.51	0.74
D	.819	.840	20.80	21.34
E	.770	.799	19.56	20.29
e	.150 BSC		3.81 BSC	
L	.780	.840	19.81	21.34
L1	.083	.102	2.11	2.59
Q	.210	.244	5.33	6.20
R	.100	.180	2.54	4.57
S	.660	.690	16.76	17.53
T	.590	.620	14.99	15.75
U	.065	.080	1.65	2.03

Ref: IXYS CO 0077 R0

**Source-Drain Diode**

Symbol	Test Conditions ( $T_J = 25^\circ\text{C}$ Unless Otherwise Specified)	Characteristic Values		
		Min.	Typ.	Max.
$I_s$	$V_{GS} = 0V$			-17 A
$I_{SM}$	Repetitive, Pulse Width Limited by $T_{JM}$			-104 A
$V_{SD}$	$I_F = -13A, V_{GS} = 0V$ , Note 1			-3.2 V
$t_{rr}$	$I_F = -13A, di/dt = 100A/\mu\text{s}$ $V_R = -100V, V_{GS} = 0V$		240	ns
$Q_{RM}$				
$I_{RM}$				

IXYS Reserves the Right to Change Limits, Test Conditions, and Dimensions.

IXYS MOSFETs and IGBTs are covered by one or more of the following U.S. patents:	4,835,592	4,931,844	5,049,961	5,237,481	6,162,665	6,404,065 B1	6,683,344	6,727,585	7,005,734 B2	7,157,338B2
	4,850,072	5,017,508	5,063,307	5,381,025	6,259,123 B1	6,534,343	6,710,405 B2	6,759,692	7,063,975 B2	
	4,881,106	5,034,796	5,187,117	5,486,715	6,306,728 B1	6,583,505	6,710,463	6,771,478 B2	7,071,537	

**N - CHANNEL**

Symbol	Test Conditions	Maximum Ratings	
$V_{DSS}$	$T_J = 25^\circ\text{C}$ to $150^\circ\text{C}$	200	V
$V_{DGR}$	$T_J = 25^\circ\text{C}$ to $150^\circ\text{C}$ , $R_{GS} = 1\text{M}\Omega$	200	V
$V_{GSS}$	Continuous	$\pm 20$	V
$V_{GSM}$	Transient	$\pm 30$	V
$I_{D25}$	$T_C = 25^\circ\text{C}$	26	A
$I_{DM}$	$T_C = 25^\circ\text{C}$ , Pulse Width Limited by $T_{JM}$	120	A
$I_A$	$T_C = 25^\circ\text{C}$	50	A
$E_{AS}$	$T_C = 25^\circ\text{C}$	1	J
$P_D$	$T_C = 25^\circ\text{C}$	125	W

Symbol	Test Conditions ( $T_J = 25^\circ\text{C}$ Unless Otherwise Specified)	Characteristic Values		
		Min.	Typ.	Max.
$BV_{DSS}$	$V_{GS} = 0\text{V}$ , $I_D = 250\mu\text{A}$	200		V
$V_{GS(th)}$	$V_{DS} = V_{GS}$ , $I_D = 250\mu\text{A}$	2.5		5.0 V
$I_{GSS}$	$V_{GS} = \pm 20\text{V}$ , $V_{DS} = 0\text{V}$			$\pm 100$ nA
$I_{DSS}$	$V_{DS} = V_{DSS}$ , $V_{GS} = 0\text{V}$ $T_J = 150^\circ\text{C}$			25 $\mu\text{A}$ 250 $\mu\text{A}$
$R_{DS(on)}$	$V_{GS} = 10\text{V}$ , $I_D = 25\text{A}$ , (Note 1)			60 m $\Omega$
$g_{fs}$	$V_{DS} = 10\text{V}$ , $I_D = 25\text{A}$ , (Note 1)	12	23	S
$C_{iss}$	} $V_{GS} = 0\text{V}$ , $V_{DS} = 25\text{V}$ , $f = 1\text{MHz}$		2720	pF
$C_{oss}$			490	pF
$C_{rss}$			105	pF
$t_{d(on)}$	} <b>Resistive Switching Times</b> $V_{GS} = 10\text{V}$ , $V_{DS} = 0.5 \cdot V_{DSS}$ , $I_D = 25\text{A}$ $R_G = 10\Omega$ (External)		26	ns
$t_r$			35	ns
$t_{d(off)}$			70	ns
$t_f$			30	ns
$Q_{g(on)}$	} $V_{GS} = 10\text{V}$ , $V_{DS} = 0.5 \cdot V_{DSS}$ , $I_D = 25\text{A}$		70	nC
$Q_{gs}$			17	nC
$Q_{gd}$			37	nC
$R_{thJC}$				1.0 $^\circ\text{C/W}$
$R_{thCS}$		0.15		$^\circ\text{C/W}$

**Source-Drain Diode**

Symbol	Test Conditions ( $T_J = 25^\circ\text{C}$ Unless Otherwise Specified)	Characteristic Values		
		Min.	Typ.	Max.
$I_S$	$V_{GS} = 0V$			26 A
$I_{SM}$	Repetitive, Pulse Width Limited by $T_{JM}$			120 A
$V_{SD}$	$I_F = 50A, V_{GS} = 0V, \text{Note 1}$			1.5 V
$t_{rr}$	$I_F = 25A, -di/dt = 100A/\mu s$ $V_R = 100V, V_{GS} = 0V$		150	ns
$Q_{RM}$			2.0	$\mu C$

Note 1: Pulse test,  $t \leq 300\mu s$ , duty cycle,  $d \leq 2\%$ .

**PRELIMINARY TECHNICAL INFORMATION**

The product presented herein is under development. The Technical Specifications offered are derived from data gathered during objective characterizations of preliminary engineering lots; but also may yet contain some information supplied during a pre-production design evaluation. IXYS reserves the right to change limits, test conditions, and dimensions without notice.