

HiPerFAST™ IGBT Lightspeed™ Series

IXGA 7N60C IXGP 7N60C

$$\begin{aligned} V_{CES} &= 600 \text{ V} \\ I_{C25} &= 14 \text{ A} \\ V_{CE(sat)} &= 2.7 \text{ V} \\ t_{fi} &= 45 \text{ ns} \end{aligned}$$

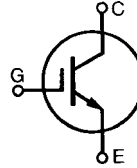

Symbol	Test Conditions	Maximum Ratings	
V_{CES}	$T_J = 25^\circ\text{C}$ to 150°C	600	V
V_{CGR}	$T_J = 25^\circ\text{C}$ to 150°C ; $R_{GE} = 1 \text{ M}\Omega$	600	V
V_{GES}	Continuous	± 20	V
V_{GEM}	Transient	± 30	V
I_{C25}	$T_C = 25^\circ\text{C}$	14	A
I_{C90}	$T_C = 90^\circ\text{C}$	7	A
I_{CM}	$T_C = 25^\circ\text{C}$, 1 ms	30	A
SSOA (RBSOA)	$V_{GE} = 15 \text{ V}$, $T_{VJ} = 125^\circ\text{C}$, $R_G = 22 \Omega$ Clamped inductive load, $L = 300 \mu\text{H}$	$I_{CM} = 14$ @ $0.8 V_{CES}$	A
P_C	$T_C = 25^\circ\text{C}$	54	W
T_J		-55 ... +150	C
T_{JM}		150	C
T_{stg}		-55 ... +150	C
Maximum lead temperature for soldering 1.6 mm (0.062 in.) from case for 10 s		300	C
M_d	Mounting torque, (TO-220)	M3 M3.5	0.45/4 Nm/lb.in. 0.55/5 Nm/lb.in.
Weight	TO-220		4 g
	TO-263		2 g

TO-220AB (IXGP)

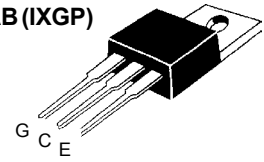

TO-263 AA (IXGA)

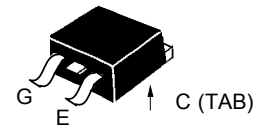

G = Gate, C = Collector,
E = Emitter, TAB = Collector

Features

- International standard packages JEDEC TO-263 surface mountable and JEDEC TO-220 AB
- High frequency IGBT
- High current handling capability
- HiPerFAST™ HDMOS™ process
- MOS Gate turn-on - drive simplicity

Applications

- Uninterruptible power supplies (UPS)
- Switched-mode and resonant-mode power supplies
- AC motor speed control
- DC servo and robot drives
- DC choppers

Advantages

- High power density
- Suitable for surface mounting
- Very low switching losses for high frequency applications

Symbol	Test Conditions	Characteristic Values ($T_J = 25^\circ\text{C}$, unless otherwise specified)		
		min.	typ.	max.
BV_{CES}	$I_C = 250 \mu\text{A}$, $V_{GE} = 0 \text{ V}$	600		V
$V_{GE(th)}$	$I_C = 250 \mu\text{A}$, $V_{CE} = V_{GE}$	2.5		5.5 V
I_{CES}	$V_{CE} = 0.8 \cdot V_{CES}$ $V_{GE} = 0 \text{ V}$	$T_J = 25^\circ\text{C}$		100 μA
		$T_J = 125^\circ\text{C}$		500 μA
I_{GES}	$V_{CE} = 0 \text{ V}$, $V_{GE} = \pm 20 \text{ V}$			$\pm 100 \text{ nA}$
$V_{CE(sat)}$	$I_C = I_{C90}$, $V_{GE} = 15 \text{ V}$	2.0	2.7	V

Symbol	Test Conditions	Characteristic Values ($T_J = 25^\circ\text{C}$, unless otherwise specified)		
		min.	typ.	max.
g_{fs}	$I_C = I_{C90}, V_{CE} = 10\text{ V}$, Pulse test, $t \leq 300\ \mu\text{s}$, duty cycle $\leq 2\%$	3	7	S
C_{ies}	$V_{CE} = 25\text{ V}, V_{GE} = 0\text{ V}, f = 1\text{ MHz}$		500	pF
C_{oes}			50	pF
C_{res}			17	pF
Q_g	$I_C = I_{C90}, V_{GE} = 15\text{ V}, V_{CE} = 0.5 V_{CES}$		25	nC
Q_{ge}			5	nC
Q_{gc}			10	nC
$t_{d(on)}$	Inductive load, $T_J = 25^\circ\text{C}$ $I_C = I_{C90}, V_{GE} = 15\text{ V}, L = 300\ \mu\text{H}$, $V_{CE} = 0.8 V_{CES}, R_G = R_{off} = 22\ \Omega$ Remarks: Switching times may increase for V_{CE} (Clamp) $> 0.8 \cdot V_{CES}$, higher T_J or increased R_G		9	ns
t_{ri}			10	ns
E_{on}			0.07	mJ
$t_{d(off)}$			65	130 ns
t_{fi}			45	110 ns
E_{off}			0.12	0.25 mJ
$t_{d(on)}$	Inductive load, $T_J = 125^\circ\text{C}$ $I_C = I_{C90}, V_{GE} = 15\text{ V}, L = 300\ \mu\text{H}$ $V_{CE} = 0.8 V_{CES}, R_G = R_{off} = 22\ \Omega$ Remarks: Switching times may increase for V_{CE} (Clamp) $> 0.8 \cdot V_{CES}$, higher T_J or increased R_G		10	ns
t_{ri}			15	ns
E_{on}			0.07	mJ
$t_{d(off)}$			120	ns
t_{fi}			85	ns
E_{off}			0.22	mJ
R_{thJC}				2.3 K/W
R_{thCK}	(TO-220)		0.25	K/W

TO-220 AB Outline

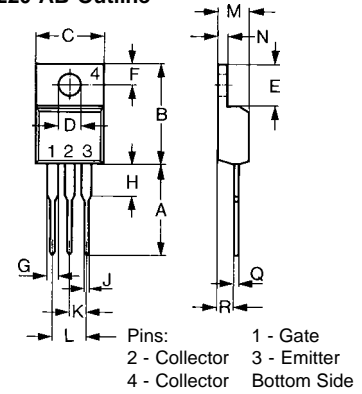

Dim.	Millimeter		Inches	
	Min.	Max.	Min.	Max.
A	12.70	13.97	0.500	0.550
B	14.73	16.00	0.580	0.630
C	9.91	10.66	0.390	0.420
D	3.54	4.08	0.139	0.161
E	5.85	6.85	0.230	0.270
F	2.54	3.18	0.100	0.125
G	1.15	1.65	0.045	0.065
H	2.79	5.84	0.110	0.230
J	0.64	1.01	0.025	0.040
K	2.54	BSC	0.100	BSC
M	4.32	4.82	0.170	0.190
N	1.14	1.39	0.045	0.055
Q	0.35	0.56	0.014	0.022
R	2.29	2.79	0.090	0.110

TO-263 AA Outline

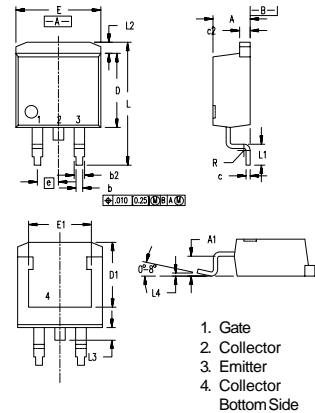

Dim.	Millimeter		Inches	
	Min.	Max.	Min.	Max.
A	4.06	4.83	.160	.190
A1	2.03	2.79	.080	.110
b	0.51	0.99	.020	.039
b2	1.14	1.40	.045	.055
c	0.46	0.74	.018	.029
c2	1.14	1.40	.045	.055
D	8.64	9.65	.340	.380
D1	7.11	8.13	.280	.320
E	9.65	10.29	.380	.405
E1	6.86	8.13	.270	.320
e	2.54	BSC	.100	BSC
L	14.61	15.88	.575	.625
L1	2.29	2.79	.090	.110
L2	1.02	1.40	.040	.055
L3	1.27	1.78	.050	.070
L4	0	0.38	0	.015
R	0.46	0.74	.018	.029

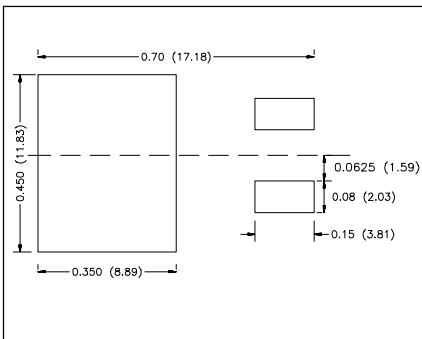

IXYS reserves the right to change limits, test conditions, and dimensions.