

# HiPerFAST™ IGBT with Diode

## IXGB 75N60BD1

$$V_{CES} = 600 \text{ V}$$

$$I_{C25} = 120 \text{ A}$$

$$V_{CE(sat)} = 2.3 \text{ V}$$

$$t_{fi} = 150 \text{ ns}$$

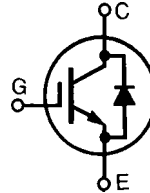

Symbol	Test Conditions	Maximum Ratings	
$V_{CES}$	$T_J = 25^\circ\text{C to } 150^\circ\text{C}$	600	V
$V_{CGR}$	$T_J = 25^\circ\text{C to } 150^\circ\text{C}; R_{GE} = 1 \text{ M}\Omega$	600	V
$V_{GES}$	Continuous	$\pm 20$	V
$V_{GEM}$	Transient	$\pm 30$	V
$I_{C25}$	$T_C = 25^\circ\text{C}$	120	A
$I_{C90}$	$T_C = 90^\circ\text{C}$	75	A
$I_{CM}$	$T_C = 25^\circ\text{C}, 1 \text{ ms}$	300	A
<b>SSOA</b> <b>(RBSOA)</b>	$V_{GE} = 15 \text{ V}, T_{VJ} = 125^\circ\text{C}, R_G = 5 \Omega$	$I_{CM} = 100$ @ $0.8 V_{CES}$	A
$P_C$	$T_C = 25^\circ\text{C}$	360	W
$T_J$		-55 ... +150	$^\circ\text{C}$
$T_{JM}$		150	$^\circ\text{C}$
$T_{stg}$		-55 ... +150	$^\circ\text{C}$
<b>Weight</b>		10	g
Maximum lead temperature for soldering 1.6 mm (0.062 in.) from case for 10 s		300	$^\circ\text{C}$

### PLUS 264

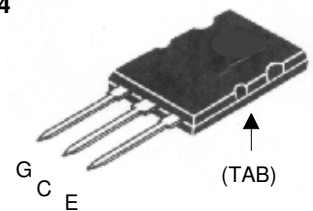

G = Gate      C = Collector  
E = Emitter    Tab = Collector

### Features

- High current handling capability in holeless TO-264 package
- High frequency IGBT and antiparallel FRED in one package
- New generation HDMOS™ process
- MOS Gate turn-on for drive simplicity
- Fast Recovery Epitaxial Diode (FRED) with soft recovery and low  $I_{RM}$

### Applications

- AC motor speed control
- DC servo and robot drives
- DC choppers
- Uninterruptible power supplies (UPS)
- Switch-mode and resonant-mode power supplies

### Advantages

- Space savings (two devices on one package)
- Easy spring or clip mounting

Symbol	Test Conditions	Characteristic Values ( $T_J = 25^\circ\text{C}$ unless otherwise specified)		
		Min.	Typ.	Max.
$BV_{CES}$	$I_C = 1 \text{ mA}, V_{GE} = 0 \text{ V}$	600		V
$V_{GE(th)}$	$I_C = 500 \mu\text{A}, V_{CE} = V_{GE}$	2.5		V
$I_{CES}$	$V_{CE} = V_{CES}$ $V_{GE} = 0 \text{ V}$ $T_J = 125^\circ\text{C}$			650 $\mu\text{A}$ 5 mA
$I_{GES}$	$V_{CE} = 0 \text{ V}, V_{GE} = \pm 20 \text{ V}$			$\pm 100 \text{ nA}$
$V_{CE(sat)}$	$I_C = I_{C90}, V_{GE} = 15 \text{ V}$ Note 1			2.3 V

Symbol	Test Conditions	Characteristic Values ( $T_J = 25^\circ\text{C}$ unless otherwise specified)			
		Min.	Typ.	Max.	
$g_{fs}$	$I_C = 60\text{A}; V_{CE} = 10\text{V}$ , Note1	45	60	S	
$C_{ies}$	$V_{CE} = 25\text{V}, V_{GE} = 0\text{V}, f = 1\text{MHz}$		5300	pF	
$C_{oes}$			730	pF	
$C_{res}$			190	pF	
$Q_g$	$I_C = I_{C90}, V_{GE} = 15\text{V}, V_{CE} = 0.5 V_{CES}$		248	nC	
$Q_{ge}$			40	nC	
$Q_{gc}$			76	nC	
$t_{d(on)}$	<b>Inductive load, <math>T_J = 25^\circ\text{C}</math></b> $I_C = I_{C90}, V_{GE} = 15\text{V}$ $V_{CE} = 0.8 V_{CES}, R_G = R_{off} = 5\ \Omega$ Remarks: Switching times may increase for $V_{CE}(\text{Clamp}) > 0.8 \cdot V_{CES}$ , higher $T_J$ or increased $R_G$		62	ns	
$t_{ri}$			57	ns	
$t_{d(off)}$			220	400	ns
$t_{fi}$			150	270	ns
$E_{off}$			3.3	6	mJ
$t_{d(on)}$	<b>Inductive load, <math>T_J = 125^\circ\text{C}</math></b> $I_C = I_{C90}, V_{GE} = 15\text{V}$ $V_{CE} = 0.8 V_{CES}, R_G = R_{off} = 5\ \Omega$ Remarks: Switching times may increase for $V_{CE}(\text{Clamp}) > 0.8 \cdot V_{CES}$ , higher $T_J$ or increased $R_G$		63	ns	
$t_{ri}$			70	ns	
$E_{on}$			5	mJ	
$t_{d(off)}$			330	ns	
$t_{fi}$			270	ns	
$E_{off}$		6.0	mJ		
$R_{thJC}$			0.35	K/W	
$R_{thCK}$		0.19		K/W	

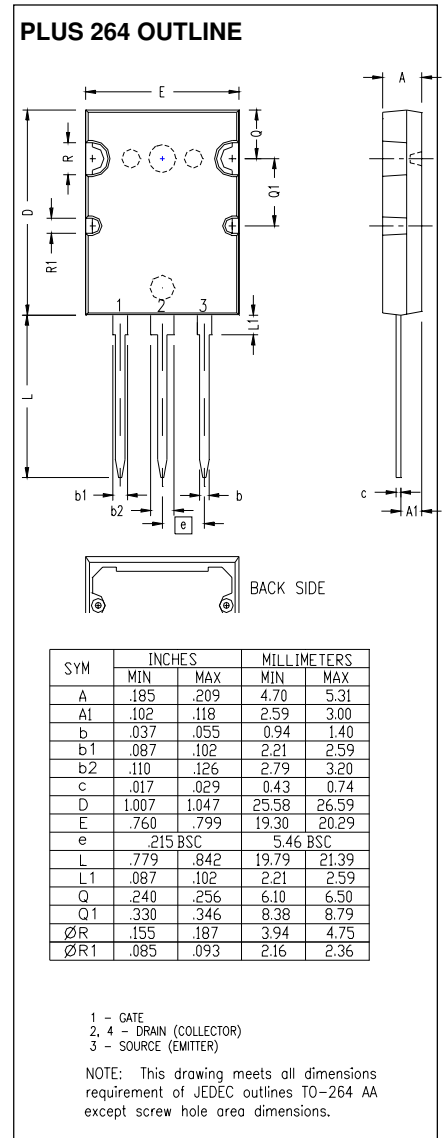

Symbol	Test Conditions	Characteristic Values ( $T_J = 25^\circ\text{C}$ unless otherwise specified)		
		min.	typ.	max.
$V_F$	$I_F = 60\text{A}, V_{GE} = 0\text{V}$ , Note1			1.6 V 2.5 V
$I_{RM}$	$I_F = I_{C90}, V_{GE} = 0\text{V}, -di_F/dt = 100\text{A/us}$ $V_R = 100\text{V}$		2	2.5 A 175 ns
$t_{rr}$	$I_F = 1\text{A}; -di/dt = 200\text{A/ms}; V_R = 30\text{V}$		35	50 ns
$R_{thJC}$				0.65 K/W

**Notes:**

1. Pulse test,  $t < 300\mu\text{s}$ , duty cycle  $< 2\%$

IXYS reserves the right to change limits, test conditions, and dimensions.