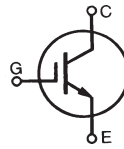

GenX3™ 600V IGBT
**IXGH64N60A3
IXGT64N60A3**
**Ultra-lowV_{sat} PT IGBTs for up to
5 kHz switching**

$$V_{CES} = 600V$$

$$I_{C110} = 64A$$

$$V_{CE(sat)} \leq 1.35V$$

| Symbol | Test Conditions | Maximum Ratings | |
|----------------|-----------------------------------------------------------|-----------------|------------|
| V_{CES} | $T_C = 25^\circ C$ to $150^\circ C$ | 600 | V |
| V_{CGR} | $T_J = 25^\circ C$ to $150^\circ C$, $R_{GE} = 1M\Omega$ | 600 | V |
| V_{GES} | Continuous | ± 20 | V |
| V_{GEM} | Transient | ± 30 | V |
| I_{C110} | $T_C = 110^\circ C$ | 64 | A |
| I_{CM} | $T_C = 25^\circ C$, 1ms | 400 | A |
| SSOA | $V_{GE} = 15V$, $T_{VJ} = 125^\circ C$, $R_G = 3\Omega$ | $I_{CM} = 100$ | A |
| (RBSOA) | Clamped inductive load @ $\leq 600V$ | | |
| P_C | $T_C = 25^\circ C$ | 460 | W |
| T_J | | -55 ... +150 | $^\circ C$ |
| T_{JM} | | 150 | $^\circ C$ |
| T_{stg} | | -55 ... +150 | $^\circ C$ |
| T_L | 1.6mm (0.062 in.) from case for 10s | 300 | $^\circ C$ |
| T_{SOLD} | Plastic body for 10 seconds | 260 | $^\circ C$ |
| M_d | Mounting torque (TO-247) | 1.13/10 | Nm/lb.in. |
| Weight | TO-247 | 6 | g |
| | TO-268 | 5 | g |

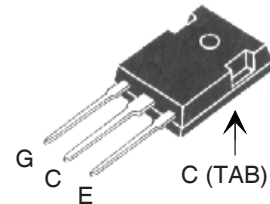
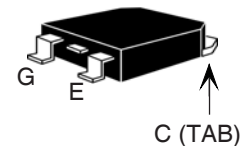
TO-247 (IXGH)

TO-268 (IXGT)

G = Gate C = Collector
E = Emitter TAB = Collector

Features

- Optimized for low conduction losses
- Square RBSOA
- International standard packages

Advantages

- High power density
- Low gate drive requirement

Applications

- Power Inverters
- UPS
- Motor Drives
- SMPS
- PFC Circuits
- Battery Chargers
- Welding Machines
- Lamp Ballasts
- Inrush Current Protection Circuits

| Symbol | Test Conditions | Characteristic Values | | |
|---------------|---------------------------------------|-----------------------|---------------------|--------------|
| | | Min. | Typ. | Max. |
| BV_{CES} | $I_C = 250\mu A$, $V_{GE} = 0V$ | 600 | | V |
| $V_{GE(th)}$ | $I_C = 250\mu A$, $V_{CE} = V_{GE}$ | 3.0 | | 5.0 V |
| I_{CES} | $V_{CE} = V_{CES}$ | | | 50 μA |
| | $V_{GE} = 0V$ | | $T_J = 125^\circ C$ | 500 μA |
| I_{GES} | $V_{CE} = 0V$, $V_{GE} = \pm 20V$ | | | ± 100 nA |
| $V_{CE(sat)}$ | $I_C = 50A$, $V_{GE} = 15V$, Note 1 | 1.20 | 1.35 | V |

| Symbol | Test Conditions | Characteristic Values | | |
|--------------|----------------------------------------------------------------------------------------------------------------------|-----------------------|------|--------------|
| | | Min. | Typ. | Max. |
| g_{fS} | $I_C = 50A, V_{CE} = 10V$, Note 1 | 40 | 70 | S |
| C_{ies} | $V_{CE} = 25V, V_{GE} = 0V, f = 1MHz$ | | 4850 | pF |
| C_{oes} | | | 270 | pF |
| C_{res} | | | 66 | pF |
| Q_g | $I_C = 50A, V_{GE} = 15V, V_{CE} = 0.5 \cdot V_{CES}$ | | 167 | nC |
| Q_{ge} | | | 28 | nC |
| Q_{gc} | | | 60 | nC |
| $t_{d(on)}$ | Inductive load, $T_J = 25^\circ C$ $I_C = 50A, V_{GE} = 15V$ $V_{CE} = 480V, R_G = 3\Omega$ | | 26 | ns |
| t_{ri} | | | 40 | ns |
| E_{on} | | | 1.42 | mJ |
| $t_{d(off)}$ | | | 268 | ns |
| t_{fi} | | | 222 | ns |
| E_{off} | | 3.28 | mJ | |
| $t_{d(on)}$ | Inductive load, $T_J = 125^\circ C$ $I_C = 50A, V_{GE} = 15V$ $V_{CE} = 480V, R_G = 3\Omega$ | | 25 | ns |
| t_{ri} | | | 40 | ns |
| E_{on} | | | 2.76 | mJ |
| $t_{d(off)}$ | | | 415 | ns |
| t_{fi} | | | 362 | ns |
| E_{off} | | 6.00 | mJ | |
| R_{thJC} | | | 0.27 | $^\circ C/W$ |
| R_{thCS} | | 0.25 | | $^\circ C/W$ |

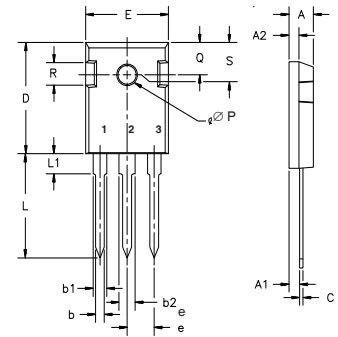
TO-247 (IXGH) Outline

 Terminals: 1 - Gate
 2 - Drain
 3 - Source
 Tab - Drain

| Dim. | Millimeter | | Inches | |
|----------------|------------|-------|--------|-------|
| | Min. | Max. | Min. | Max. |
| A | 4.7 | 5.3 | .185 | .209 |
| A ₁ | 2.2 | 2.54 | .087 | .102 |
| A ₂ | 2.2 | 2.6 | .059 | .098 |
| b | 1.0 | 1.4 | .040 | .055 |
| b ₁ | 1.65 | 2.13 | .065 | .084 |
| b ₂ | 2.87 | 3.12 | .113 | .123 |
| C | .4 | .8 | .016 | .031 |
| D | 20.80 | 21.46 | .819 | .845 |
| E | 15.75 | 16.26 | .610 | .640 |
| e | 5.20 | 5.72 | 0.205 | 0.225 |
| L | 19.81 | 20.32 | .780 | .800 |
| L ₁ | | 4.50 | | .177 |
| ∅P | 3.55 | 3.65 | .140 | .144 |
| Q | 5.89 | 6.40 | 0.232 | 0.252 |
| R | 4.32 | 5.49 | .170 | .216 |
| S | 6.15 | BSC | 242 | BSC |

 Note 1: Pulse test, $t \leq 300\mu s$, duty cycle, $d \leq 2\%$.

PRELIMINARY TECHNICAL INFORMATION

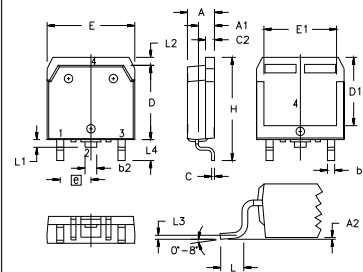
The product presented herein is under development. The Technical Specifications offered are derived from data gathered during objective characterizations of preliminary engineering lots; but also may yet contain some information supplied during a pre-production design evaluation. IXYS reserves the right to change limits, test conditions, and dimensions without notice.

TO-268 (IXGT) Outline

| SYM | INCHES | | MILLIMETERS | |
|-----|--------|----------|-------------|----------|
| | MIN | MAX | MIN | MAX |
| A | .193 | .201 | 4.90 | 5.10 |
| A1 | .106 | .114 | 2.70 | 2.90 |
| A2 | .001 | .010 | 0.02 | 0.25 |
| b | .045 | .057 | 1.15 | 1.45 |
| b2 | .075 | .083 | 1.90 | 2.10 |
| C | .016 | .026 | 0.40 | 0.65 |
| C2 | .057 | .063 | 1.45 | 1.60 |
| D | .543 | .551 | 13.80 | 14.00 |
| D1 | .488 | .500 | 12.40 | 12.70 |
| E | .624 | .632 | 15.85 | 16.05 |
| E1 | .524 | .535 | 13.30 | 13.60 |
| e | | .215 BSC | | 5.45 BSC |
| H | .736 | .752 | 18.70 | 19.10 |
| L | .094 | .106 | 2.40 | 2.70 |
| L1 | .047 | .055 | 1.20 | 1.40 |
| L2 | .039 | .045 | 1.00 | 1.15 |
| L3 | | .010 BSC | | 0.25 BSC |
| L4 | .150 | .161 | 3.80 | 4.10 |

IXYS reserves the right to change limits, test conditions and dimensions.

| | | | | | | | | | | |
|----------------------------------------------------------------------------------|-----------|-----------|-----------|-----------|--------------|--------------|--------------|--------------|--------------|-------------|
| IXYS MOSFETs and IGBTs are covered by one or more of the following U.S. patents: | 4,835,592 | 4,931,844 | 5,049,961 | 5,237,481 | 6,162,665 | 6,404,065 B1 | 6,683,344 | 6,727,585 | 7,005,734 B2 | 7,157,338B2 |
| | 4,850,072 | 5,017,508 | 5,063,307 | 5,381,025 | 6,259,123 B1 | 6,534,343 | 6,710,405 B2 | 6,759,692 | 7,063,975 B2 | |
| | 4,881,106 | 5,034,796 | 5,187,117 | 5,486,715 | 6,306,728 B1 | 6,583,505 | 6,710,463 | 6,771,478 B2 | 7,071,537 | |

Fig. 1. Output Characteristics @ 25°C

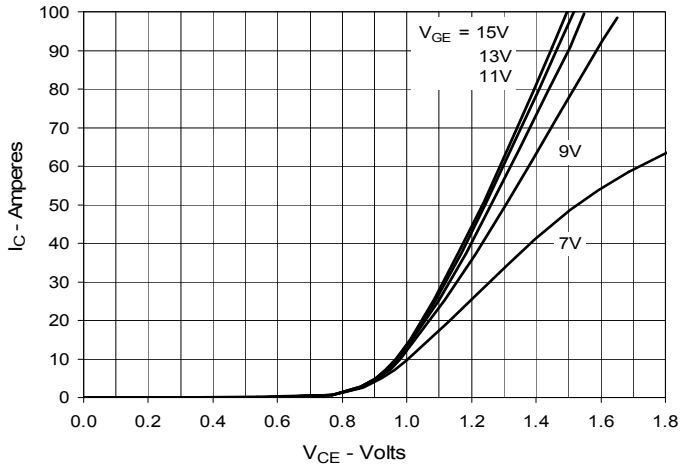

Fig. 2. Extended Output Characteristics @ 25°C

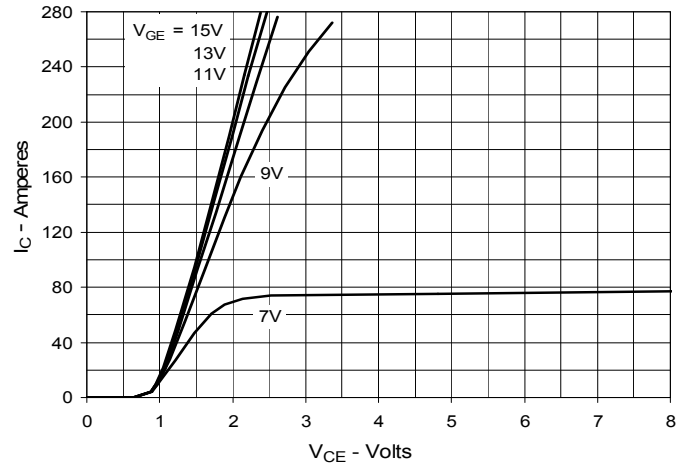

Fig. 3. Output Characteristics @ 125°C

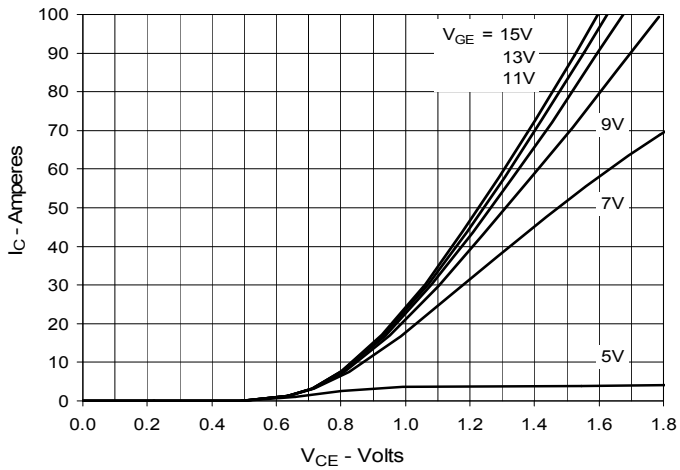

Fig. 4. Dependence of $V_{CE(sat)}$ on Junction Temperature

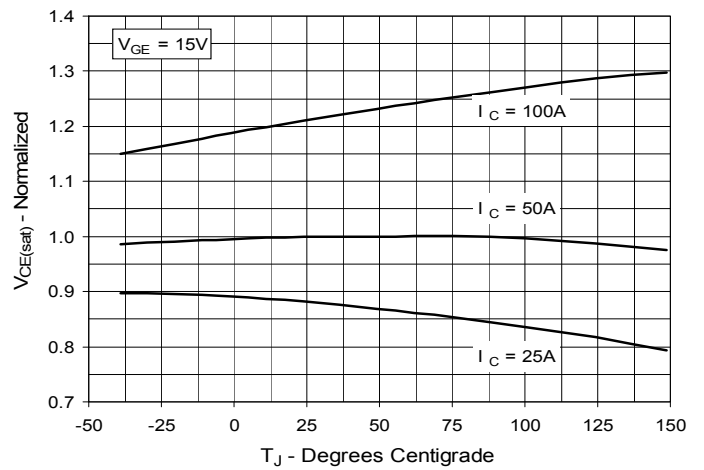

Fig. 5. Collector-to-Emitter Voltage vs. Gate-to-Emitter Voltage

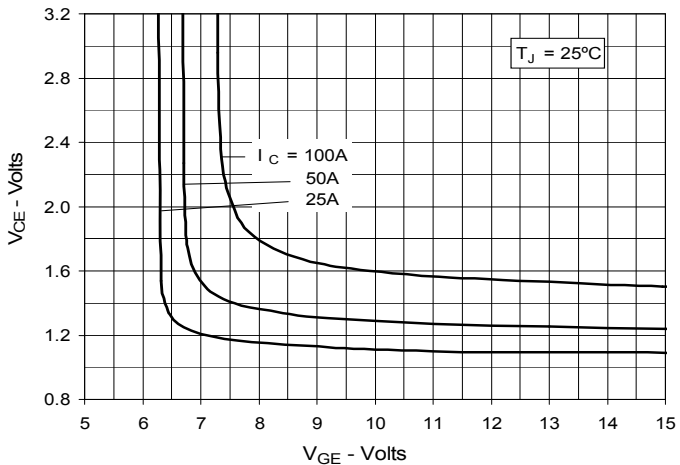

Fig. 6. Input Admittance

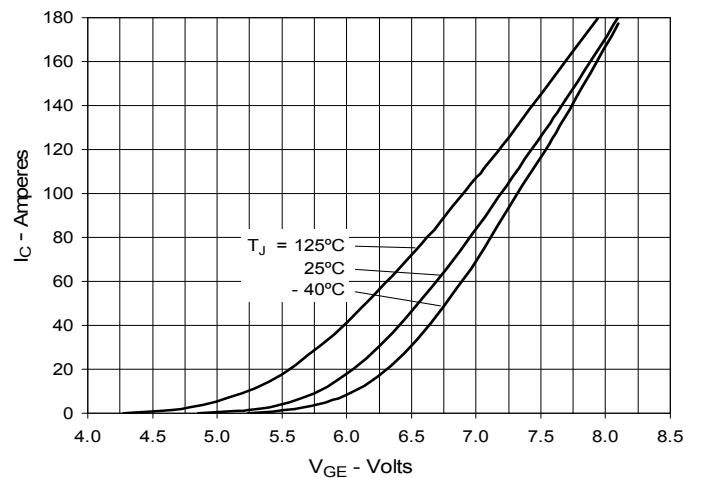

Fig. 7. Transconductance

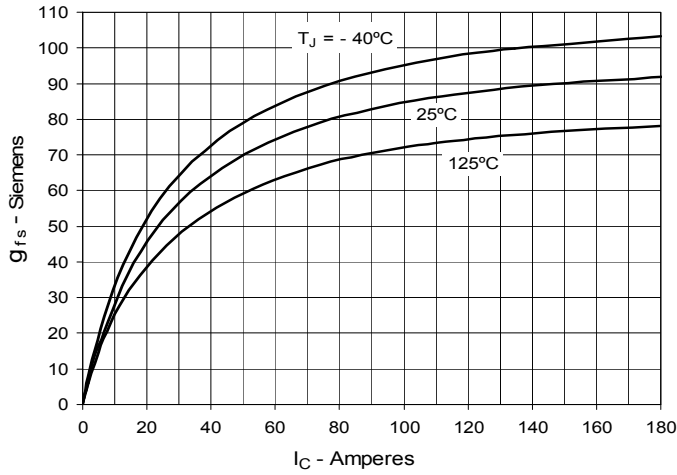

Fig. 8. Gate Charge

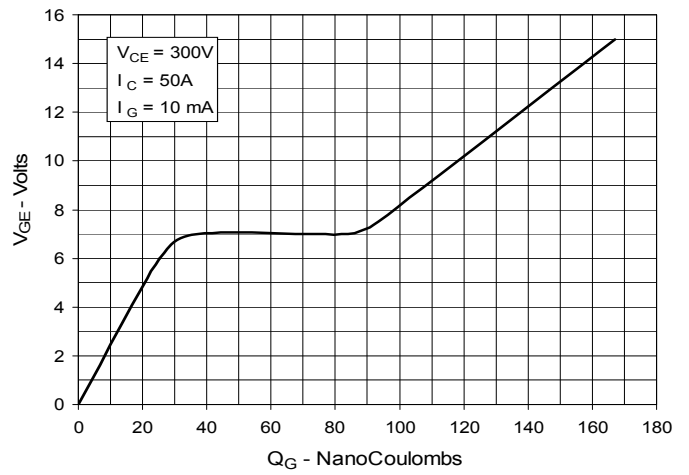

Fig. 9. Capacitance

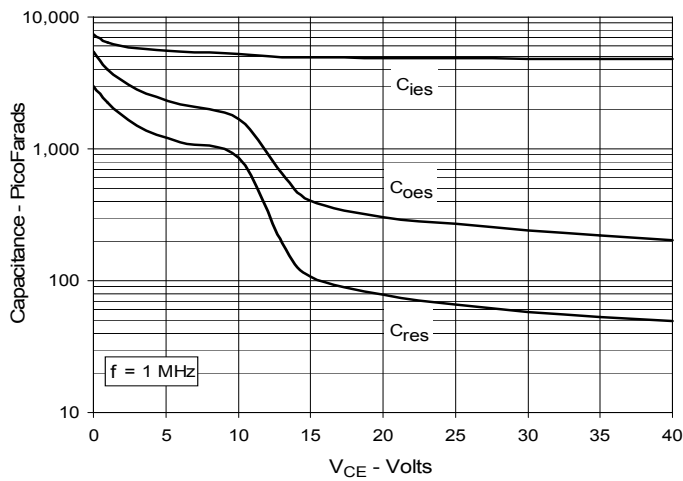

Fig. 10. Reverse-Bias Safe Operating Area

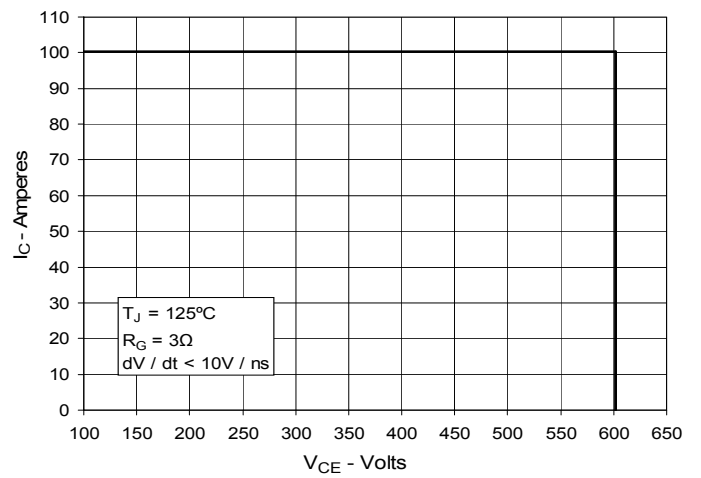
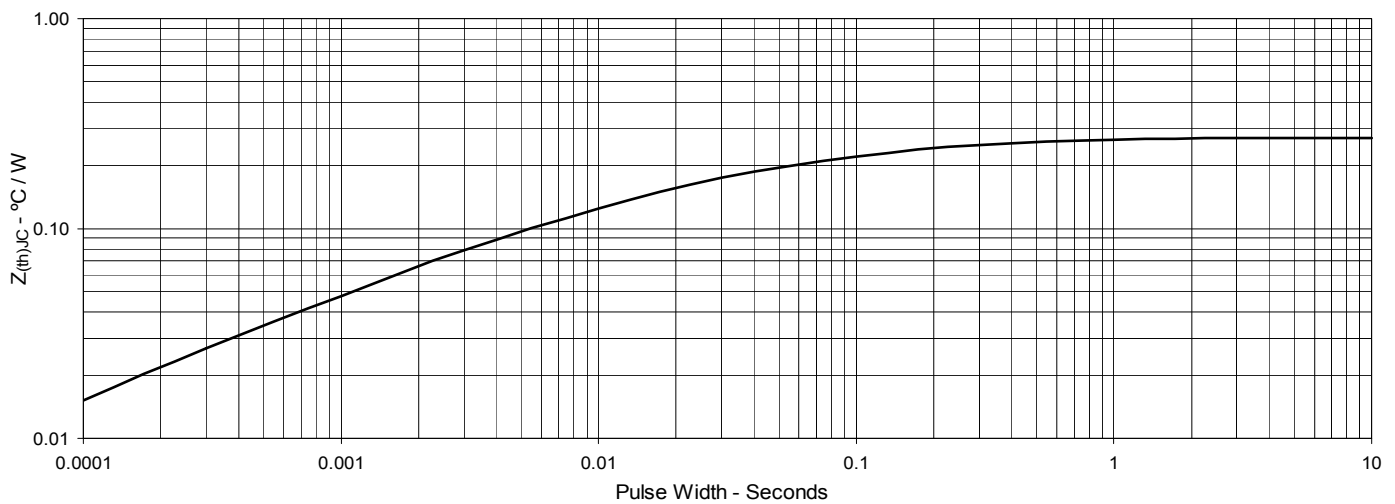

Fig. 11. Maximum Transient Thermal Impedance



IXYS reserves the right to change limits, test conditions and dimensions.

Fig. 12. Inductive Switching Energy Loss vs. Gate Resistance

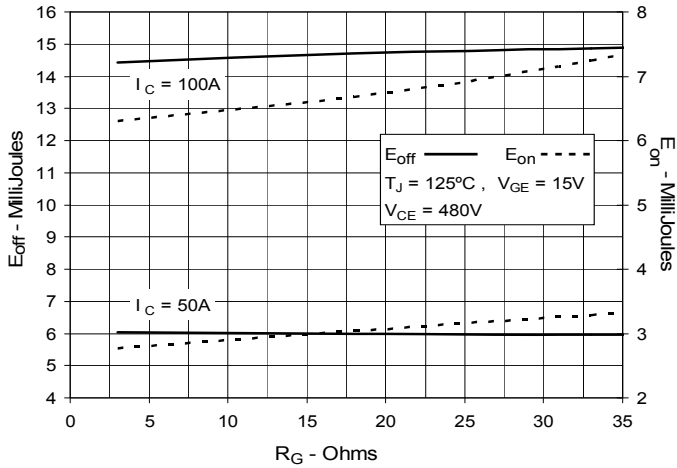

Fig. 13. Inductive Switching Energy Loss vs. Junction Temperature

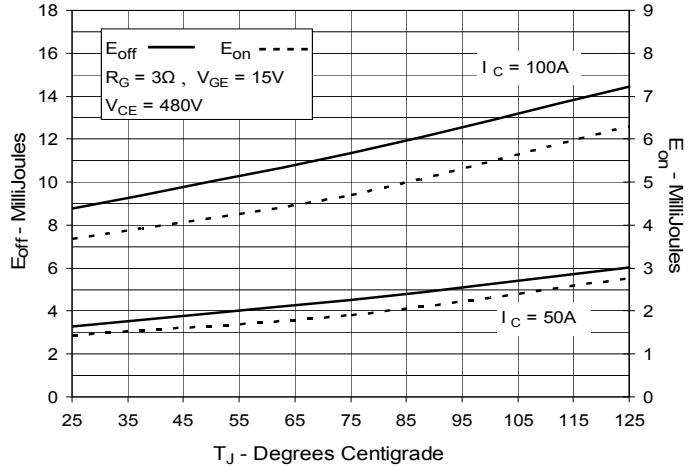

Fig. 14. Inductive Switching Energy Loss vs. Collector Current

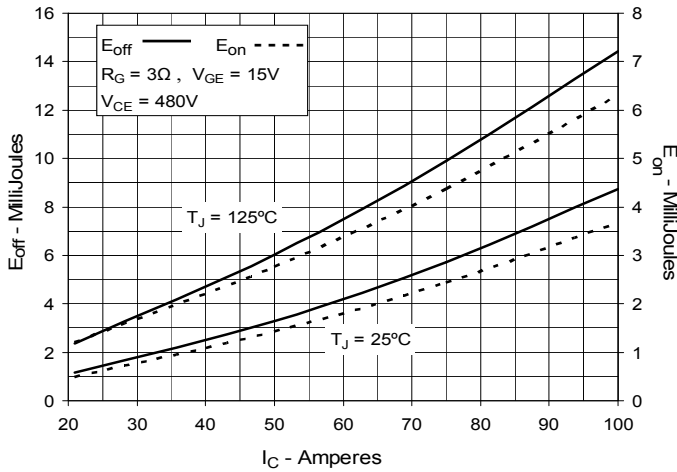

Fig. 15. Inductive Turn-off Switching Times vs. Gate Resistance

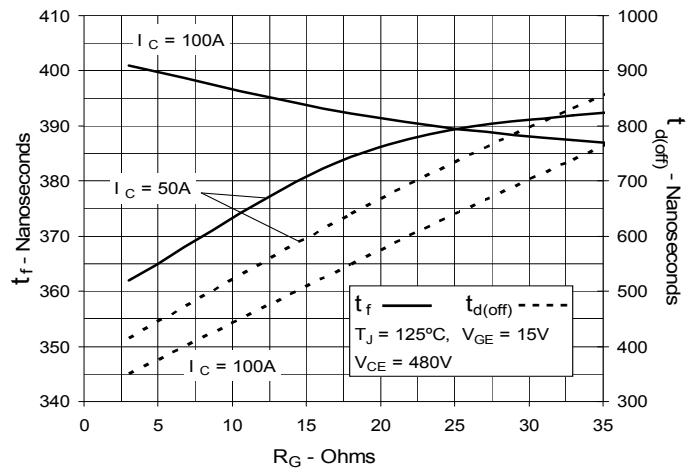

Fig. 16. Inductive Turn-off Switching Times vs. Collector Current

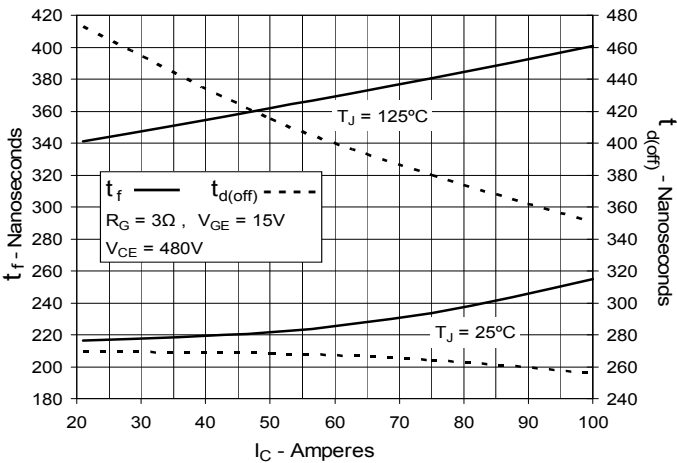
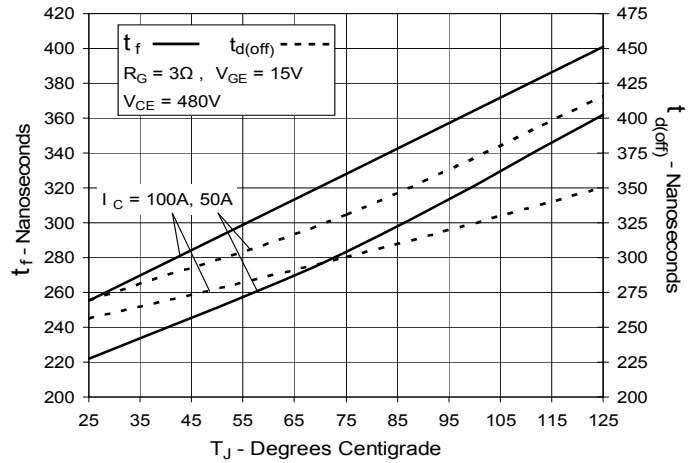
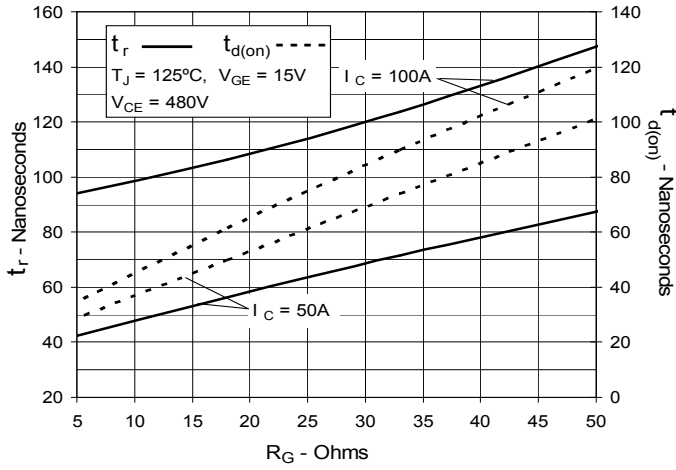

Fig. 17. Inductive Turn-off Switching Times vs. Junction Temperature



**Fig. 18. Inductive Turn-on
Switching Times vs. Gate Resistance**



**Fig. 19. Inductive Turn-on
Switching Times vs. Junction Temperature**

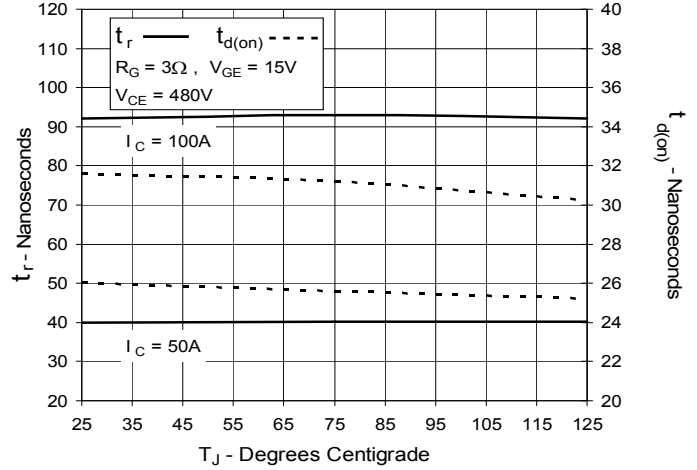

**Fig. 20. Inductive Turn-on
Switching Times vs. Collector Current**

