

Phase-leg Rectifier Diode

$$V_{RRM} = 800/1200 \text{ V}$$

$$I_{F(RMS)} = 2 \times 17 \text{ A}$$

$$I_{F(AV)M} = 2 \times 11 \text{ A}$$

V_{RSM}	V_{RRM}	TO-220 AB	TO-263 AA	TO-263AB
V	V	Type		
900	800	DSP 8-08A	DSP 8-08AS	DSP 8-08S
1300	1200	DSP 8-12A	DSP 8-12AS	DSP 8-12S

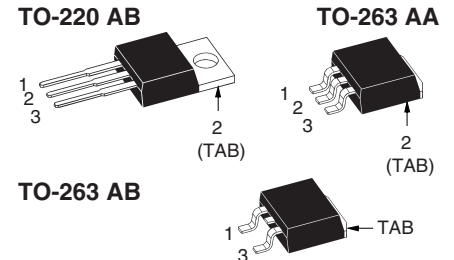
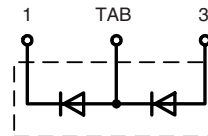

1 = Cathode, 2 = Anode/Cathode, 3 = Anode
TAB = Anode/Cathode

Symbol	Conditions	Maximum Ratings	
I_{FRMS}	$T_{VJ} = T_{VJM}$	17	A
$I_{F(AV)M}$	$T_{case} = 100^{\circ}\text{C}; 180^{\circ}$ sine	11	A
I_{FSM}	$T_{VJ} = 45^{\circ}\text{C};$ $t = 10 \text{ ms}$ (50 Hz), sine $t = 8.3 \text{ ms}$ (60 Hz), sine	100	A
		110	A
I^2t	$T_{VJ} = 45^{\circ}\text{C};$ $t = 10 \text{ ms}$ (50 Hz), sine $t = 8.3 \text{ ms}$ (60 Hz), sine	90	A
		100	A
I^2t	$T_{VJ} = 150^{\circ}\text{C};$ $t = 10 \text{ ms}$ (50 Hz), sine $t = 8.3 \text{ ms}$ (60 Hz), sine	50	A ² s
		50	A ² s
I^2t	$T_{VJ} = 150^{\circ}\text{C};$ $t = 10 \text{ ms}$ (50 Hz), sine $t = 8.3 \text{ ms}$ (60 Hz), sine	41	A ² s
		42	A ² s
T_{VJ}		-40...+180	$^{\circ}\text{C}$
T_{VJM}		180	$^{\circ}\text{C}$
T_{stg}		-40...+150	$^{\circ}\text{C}$
$M_d^{1)}$	Mounting torque	0.4...0.6	Nm
Weight		TO-263/TO-220	2/4 g

Features

- International standard packages JEDEC TO-220 AB and TO-263 AA surface mountable
- For single and three phase bridge configuration
- Planar passivated chips
- Epoxy meets UL 94V-0 flammability classification

Symbol	Conditions	Characteristic Values	
I_R	$T_{VJ} = 25^{\circ}\text{C}$ $V_R = V_{RRM}$	\leq	5 μA
V_F	$I_F = 7 \text{ A}; T_{VJ} = 25^{\circ}\text{C}$	\leq	1.15 V
V_{T0}	For power-loss calculations only		0.8 V
r_T	$T_{VJ} = T_{VJM}$		40 m Ω
R_{thJC}	DC current		3.5 K/W
$R_{thCH}^{1)}$	DC current (with heatsink compound)	typ.	0.5 K/W
a	Maximum allowable acceleration		100 m/s ²

¹⁾ TO-220 only
Data according to IEC 60747 and refer to a single diode unless otherwise stated.

TO-220 AB Outline

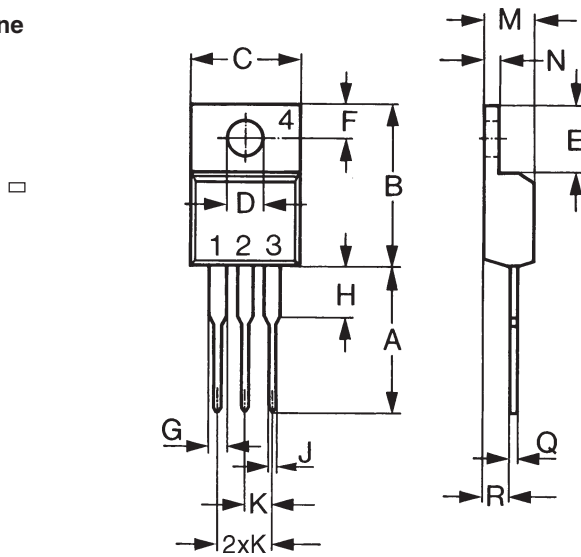

Dim.	Millimeter		Inches	
	Min.	Max.	Min.	Max.
A	12.70	13.97	0.500	0.550
B	14.73	16.00	0.580	0.630
C	9.91	10.66	0.390	0.420
D	3.54	4.08	0.139	0.161
E	5.85	6.85	0.230	0.270
F	2.54	3.18	0.100	0.125
G	1.15	1.65	0.045	0.065
H	2.79	5.84	0.110	0.230
J	0.64	1.01	0.025	0.040
K	2.54	BSC	0.100	BSC
M	4.32	4.82	0.170	0.190
N	1.14	1.39	0.045	0.055
Q	0.38	0.56	0.015	0.022
R	2.29	2.79	0.090	0.110

TO-263 AA Outline

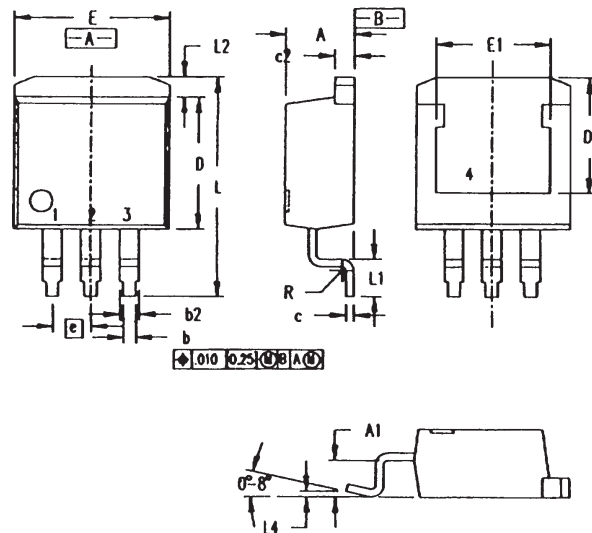

Dim.	Millimeter		Inches	
	Min.	Max.	Min.	Max.
A	4.06	4.83	.160	.190
A1	2.03	2.79	.080	.110
b	0.51	0.99	.020	.039
b2	1.14	1.40	.045	.055
c	0.46	0.74	.018	.029
c2	1.14	1.40	.045	.055
D	8.64	9.65	.340	.380
D1	7.11	8.13	.280	.320
E	9.65	10.29	.380	.405
E1	6.86	8.13	.270	.320
e	2.54 BSC		.100 BSC	
L	14.61	15.88	.575	.625
L1	2.29	2.79	.090	.110
L2	1.02	1.68	.040	.066
L4	0	0.38	0	.015
R	0.46	0.74	.018	.029

TO-263 AB Outline

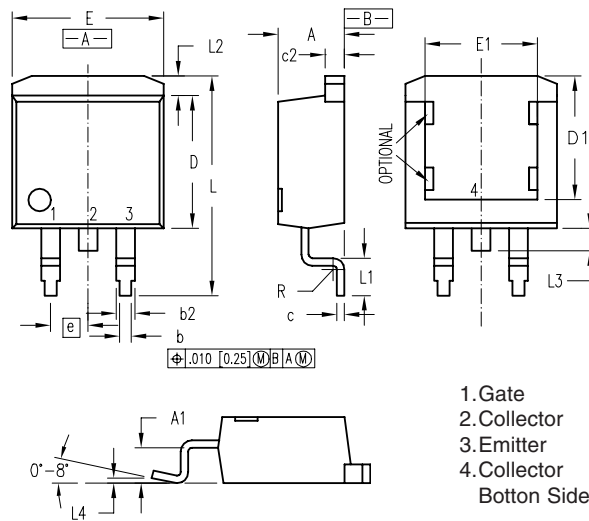

Dim.	Millimeter		Inches	
	Min.	Max.	Min.	Max.
A	4.06	4.83	.160	.190
A1	2.03	2.79	.080	.110
b	0.51	0.99	.020	.039
b2	1.14	1.40	.045	.055
c	0.46	0.74	.018	.029
c2	1.14	1.40	.045	.055
D	8.64	9.65	.340	.380
D1	8.00	8.89	.315	.350
E	9.65	10.29	.380	.405
E1	6.22	8.13	.245	.320
e	2.54 BSC		.100 BSC	
L	14.61	15.88	.575	.625
L1	2.29	2.79	.090	.110
L2	1.02	1.68	.040	.066
L3	1.27	1.78	.050	.070
L4	0	0.20	0	.008
R	0.46	0.74	.018	.029

1. Gate
 2. Collector
 3. Emitter
 4. Collector
- Bottom Side

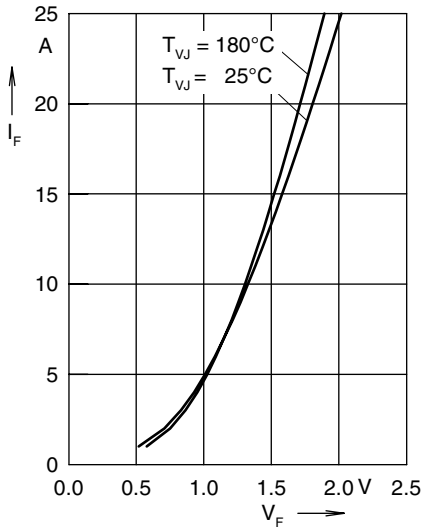

Fig. 1 Forward current versus voltage drop per diode

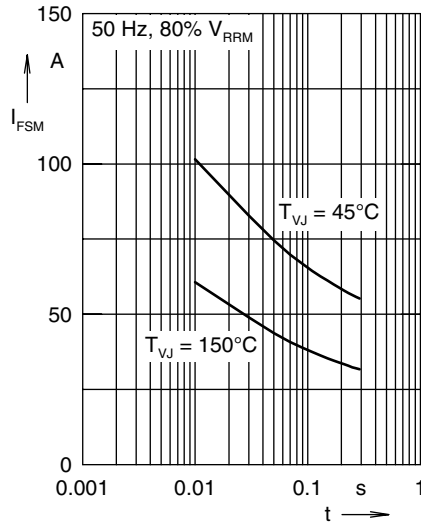

Fig. 2 Surge overload current

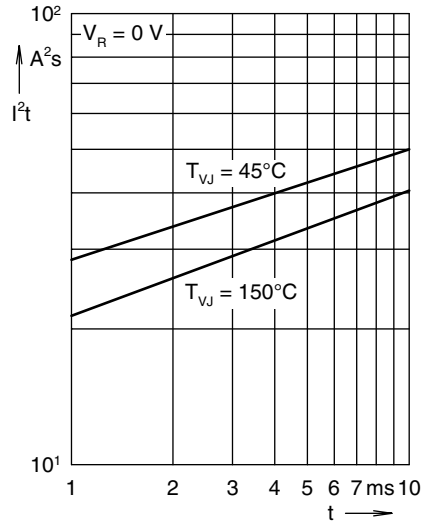

Fig. 3 I^2t versus time per diode

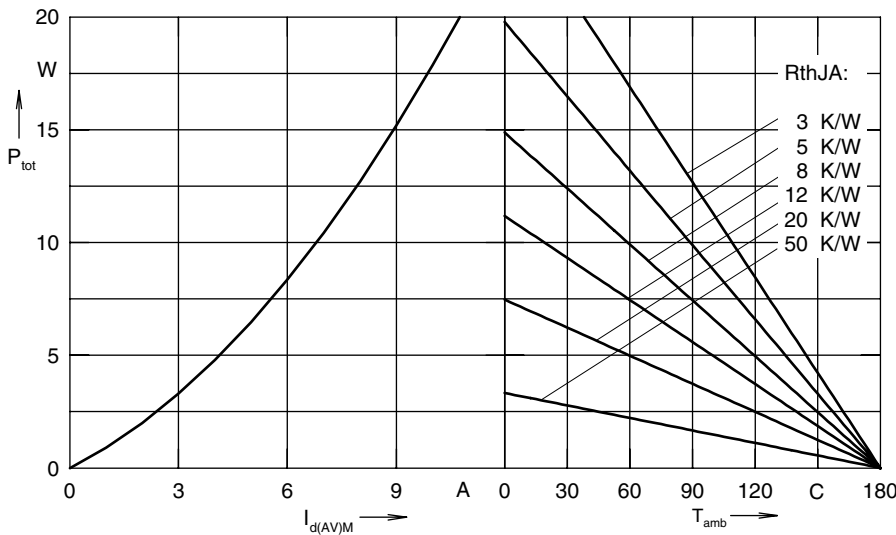

Fig. 4 Power dissipation versus direct output current and ambient temperature, sine 180°

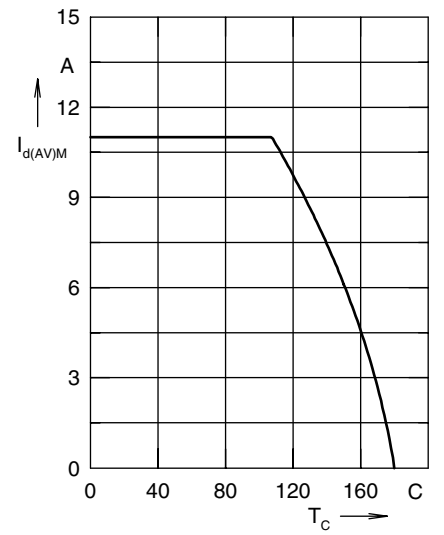

Fig. 5 Max. forward current versus case temperature

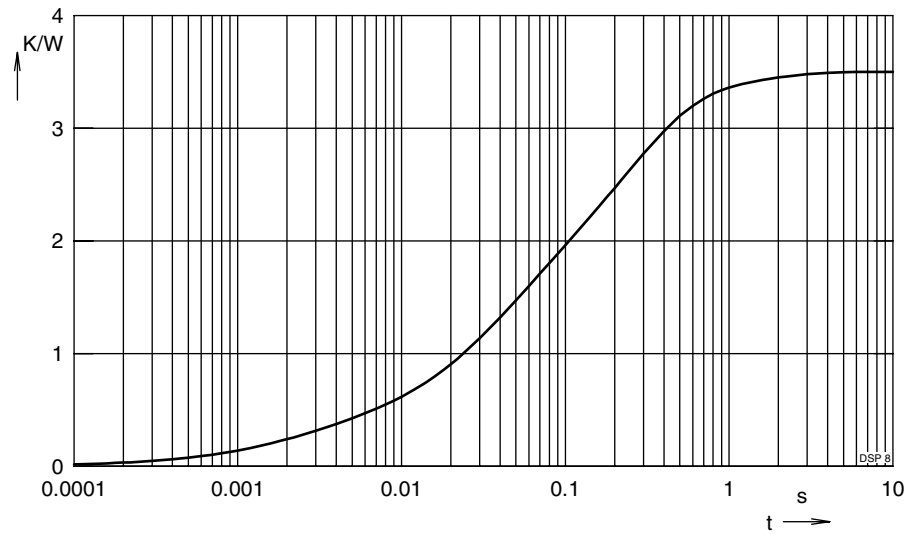

Fig. 6 Transient thermal impedance junction to case

Constants for Z_{thJC} calculation:

i	R_{thi} (K/W)	t_i (s)
1	0.252	0.002
2	1.045	0.032
3	1.932	0.227
4	0.271	1.2