

Phase-leg Rectifier Diode ISOPLUS220™ Electrically Isolated Back Surface

$$V_{RRM} = 800/1200 \text{ V}$$

$$I_{F(AV)M} = 2 \times 11 \text{ A}$$

V_{RSM} V	V_{RRM} V	Type
900	800	DSP 8-08AC
1300	1200	DSP 8-12AC

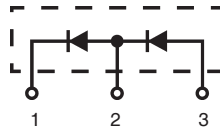

ISOPLUS 220™
E153432

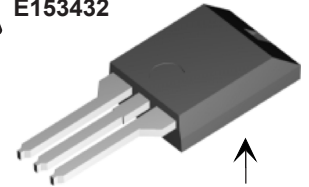

Isolated back surface*

Preliminary Data Sheet

Symbol	Test Conditions	Maximum Ratings
I_{FRMS}	$T_{VJ} = T_{VJM}$	30 A
$I_{F(AV)M}$	$T_{case} = 100^\circ\text{C}; 180^\circ \text{ sine}$	2 x 11 A
I_{FSM}	$T_{VJ} = 45^\circ\text{C}; t = 10 \text{ ms}$ (50 Hz), sine	100 A
	$t = 8.3 \text{ ms}$ (60 Hz), sine	105 A
	$T_{VJ} = 150^\circ\text{C}; t = 10 \text{ ms}$ (50 Hz), sine	85 A
	$t = 8.3 \text{ ms}$ (60 Hz), sine	90 A
I^2t	$T_{VJ} = 45^\circ\text{C}; t = 10 \text{ ms}$ (50 Hz), sine	50 A ² s
	$t = 8.3 \text{ ms}$ (60 Hz), sine	45 A ² s
	$T_{VJ} = 150^\circ\text{C}; t = 10 \text{ ms}$ (50 Hz), sine	35 A ² s
	$t = 8.3 \text{ ms}$ (60 Hz), sine	30 A ² s
T_{VJ}		-40...+150 °C
T_{VJM}		150 °C
T_{stg}		-55...+150 °C
T_L	1.6 mm (0.063 in) from case for 10 s	260 °C
V_{ISOL}	50/60 Hz RMS; $I_{ISOL} \leq 1 \text{ mA}$	2500 V~
F_c	Mounting Force	11...65 / 2.5..15 N/lb
Weight		2 g

Features

- Silicon chip on Direct-Copper-Bond substrate
- High power dissipation
- Isolated mounting surface
- 2500V electrical isolation
- For single and three phase bridge configuration
- Low cathode to tab capacitance (<15pF)
- Planar passivated chips
- Epoxy meets UL 94V-0

Symbol	Test Conditions	Characteristic Values
I_R ①	$V_R = V_{RRM}; T_{VJ} = 25^\circ\text{C}$	$\leq 10 \mu\text{A}$
	$T_{VJ} = 150^\circ\text{C}$	$\leq 0.7 \text{ mA}$
V_F ②	$I_F = 10 \text{ A}; T_{VJ} = 25^\circ\text{C}$	$\leq 1.22 \text{ V}$
	$T_{VJ} = 125^\circ\text{C}$	$\leq 1.26 \text{ V}$
V_{T0}	For power-loss calculations only	0.8 V
r_T	$T_{VJ} = T_{VJM}$	41 mΩ
R_{thJC}	DC current	1.8 K/W
R_{thCK}	DC current (with heatsink compound)	typ. 0.6 K/W
a	Maximum allowable acceleration	100 m/s ²

Notes: Data given for $T_{VJ} = 25^\circ\text{C}$ and per diode unless otherwise specified

① Pulse test: pulse Width = 5 ms, Duty Cycle < 2.0 %

② Pulse test: pulse Width = 300 μs, Duty Cycle < 2.0 %

IXYS reserves the right to change limits, test conditions and dimensions.

ISOPLUS220 Outline

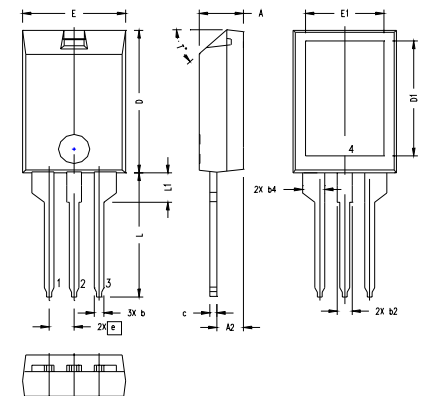

SYM	INCHES		MILLIMETERS	
	MIN	MAX	MIN	MAX
A	.157	.197	4.00	5.00
A2	.098	.118	2.50	3.00
b	.035	.051	0.90	1.30
b2	.049	.065	1.25	1.65
b4	.093	.100	2.35	2.55
c	.028	.039	0.70	1.00
D	.591	.630	15.00	16.00
D1	.472	.512	12.00	13.00
E	.394	.433	10.00	11.00
E1	.295	.335	7.50	8.50
e	.100 BASIC 2.55 BASIC			
L	.512	.571	13.00	14.50
L1	.118	.138	3.00	3.50
T*			42.5°	47.5°

NOTE:

1. Bottom heatsink (Pin 4) is electrically isolated from Pin 1, 2, or 3.
2. This drawing will meet dimensional requirement of JEDEC SS Product Outline TO-273 except D and D1 dimension.