

# Single Phase Rectifier Bridge

 $I_{dAV} = 52/72 \text{ A}$   
 $V_{RRM} = 800-1800 \text{ V}$ 

$V_{RSM}$	$V_{RRM}$	Type	
V	V		
900	800	VBO 52-08NO7	VBO 72-08NO7
1300	1200	VBO 52-12NO7	VBO 72-12NO7
1700	1600	VBO 52-16NO7	VBO 72-16NO7
1900	1800	VBO 52-18NO7	VBO 72-18NO7

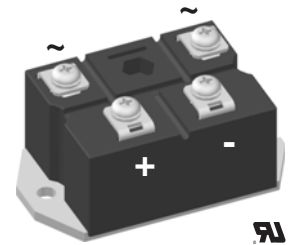
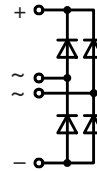

Symbol	Conditions	Maximum Ratings			
		VBO 52	VBO 72		
$I_{dAV}$	$T_C = 100^\circ\text{C}$ , module	52	72	A	
$I_{dAV}$	$T_A = 45^\circ\text{C}$ ( $R_{thCA} = 0.6 \text{ K/W}$ ), module	41	49	A	
$I_{FSM}$	$T_{VJ} = 45^\circ\text{C}$ ; $V_R = 0$	t = 10 ms (50 Hz), sine t = 8.3 ms (60 Hz), sine	550 600	750 820	A A
	$T_{VJ} = T_{VJM}$ t = 10 ms (50 Hz), sine $V_R = 0$	t = 8.3 ms (60 Hz), sine	500 550	670 740	A A
$I^2t$	$T_{VJ} = 45^\circ\text{C}$	t = 10 ms (50 Hz), sine t = 8.3 ms (60 Hz), sine	1520 1520	2800 2800	$\text{A}^2\text{s}$ $\text{A}^2\text{s}$
	$T_{VJ} = T_{VJM}$ $V_R = 0$	t = 10 ms (50 Hz), sine t = 8.3 ms (60 Hz), sine	1250 1250	2250 2250	$\text{A}^2\text{s}$ $\text{A}^2\text{s}$
$T_{VJ}$		-40...+150		$^\circ\text{C}$	
$T_{VJM}$		150		$^\circ\text{C}$	
$T_{stg}$		-40...+125		$^\circ\text{C}$	
$V_{ISOL}$	50/60 Hz, RMS	t = 1 min	2500	V~	
	$I_{ISOL} \leq 1 \text{ mA}$	t = 1 s	3000	V~	
$M_d$	Mounting torque (M5)		5 ±15%	Nm	
	Terminal connection torque (M5)		5 ±15%	Nm	
Weight	typ.		160	g	

## Features

- Package with screw terminals
- Isolation voltage 3000 V~
- Planar passivated chips
- Blocking voltage up to 1800 V
- Low forward voltage drop
- UL registered E 72873

## Applications

- Supplies for DC power equipment
- Input rectifiers for PWM inverter
- Battery DC power supplies
- Field supply for DC motors

## Advantages

- Easy to mount with two screws
- Space and weight savings
- Improved temperature & power cycling

## Dimensions in mm (1 mm = 0.0394")

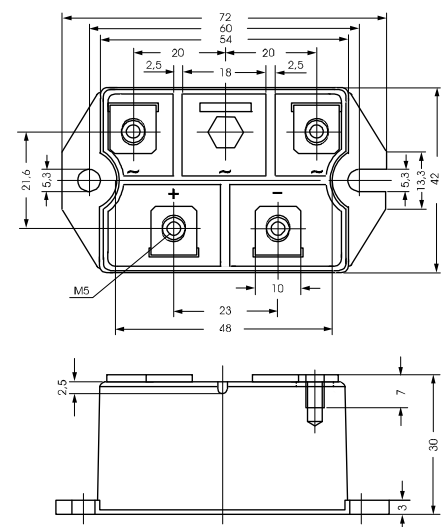

Symbol	Conditions	Characteristic Values		
		VBO 52	VBO 72	
$I_R$	$V_R = V_{RRM}$ ; $T_{VJ} = 25^\circ\text{C}$	$\leq 0.3$	0.3	mA
	$V_R = V_{RRM}$ ; $T_{VJ} = T_{VJM}$	$\leq 5$	5	mA
$V_F$	$I_F = 150 \text{ A}$ ; $T_{VJ} = 25^\circ\text{C}$	$\leq 1.8$	1.6	V
$V_{T0}$	For power-loss calculations only	0.8	0.8	V
$r_T$	$T_{VJ} = T_{VJM}$	8	5	mΩ
$R_{thJC}$	per diode	1.45	1.1	K/W
	per module	0.36	0.28	K/W
$R_{thJK}$	per diode	1.87	1.52	K/W
	per module	0.47	0.38	K/W
$d_s$	Creeping distance on surface	10		mm
$d_A$	Creepage distance in air	9.4		mm
$a$	Max. allowable acceleration	50		$\text{m/s}^2$

Data according to IEC 60747 refer to a single diode unless otherwise stated.

IXYS reserves the right to change limits, test conditions and dimensions.

20100706a

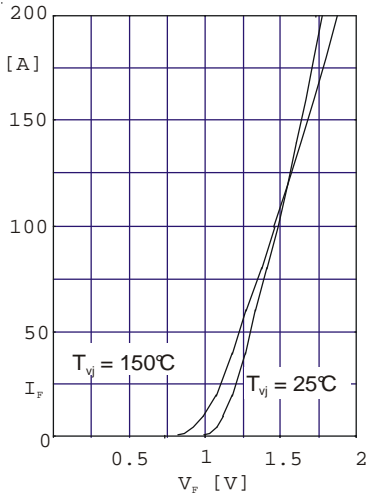

Fig. 1 Forward current versus voltage drop per diode

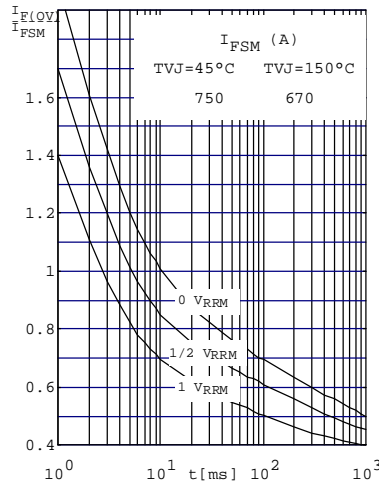

Fig. 2 Surge overload current per diode  $I_{FSM}$ : Crest value. t: duration

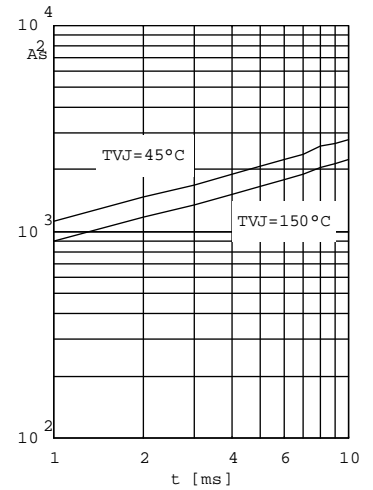

Fig. 3  $I^2dt$  versus time (1-10ms) per diode or thyristor

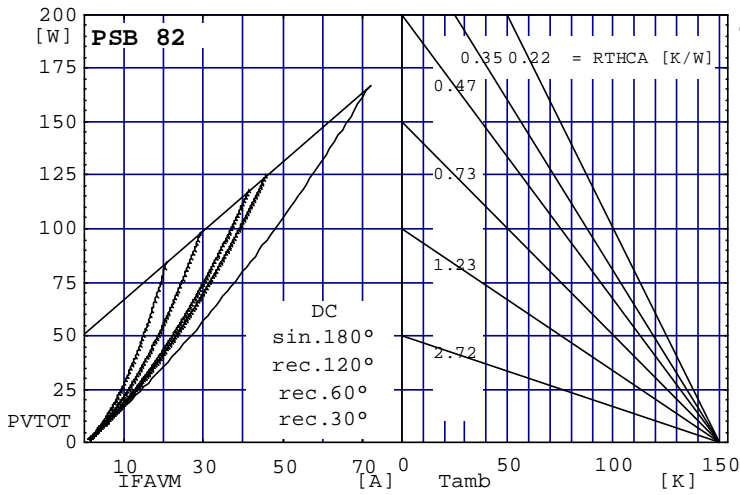

Fig. 4 Power dissipation vs. direct output current and ambient temperature

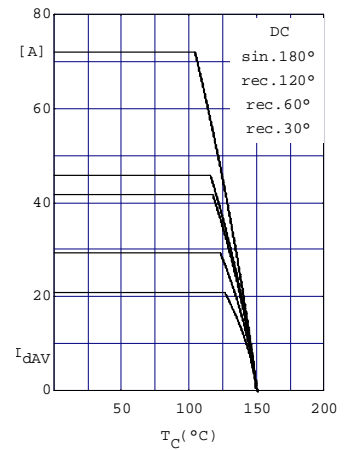

Fig. 5 Maximum forward current at case temperature

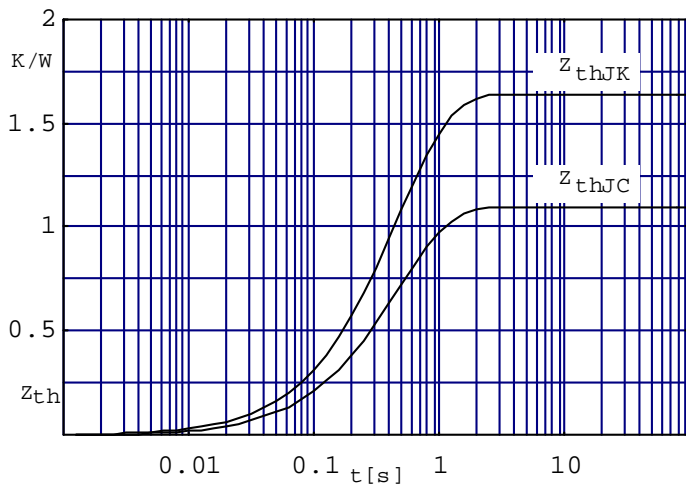

Fig. 6 Transient thermal impedance per diode or thyristor, calculated