

Single Phase Rectifier Bridge

$I_{dAV} = 68 \text{ A}$
 $V_{RRM} = 800-1600 \text{ V}$

Preliminary data

V_{RSM} V	V_{RRM} V	Types
900	800	VBO 68-08NO7
1300	1200	VBO 68-12NO7
1700	1600	VBO 68-16NO7

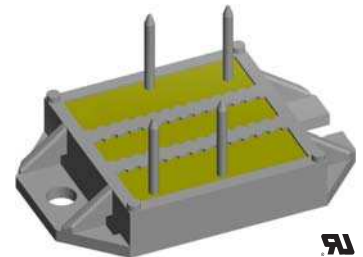
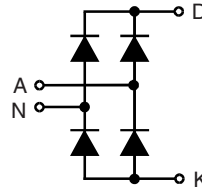

Symbol	Conditions	Maximum Ratings
I_{dAV}^*	$T_C = 90^\circ\text{C}$, module	68 A
I_{FSM}	$T_{VJ} = 45^\circ\text{C}$ $V_R = 0$	t = 10 ms (50 Hz), sine 530 A t = 8.3 ms (60 Hz), sine 570 A
	$T_{VJ} = T_{VJM}$ $V_R = 0$	t = 10 ms (50 Hz), sine 480 A t = 8.3 ms (60 Hz), sine 520 A
I^2t	$T_{VJ} = 45^\circ\text{C}$ $V_R = 0$	t = 10 ms (50 Hz), sine 1400 A ² s t = 8.3 ms (60 Hz), sine 1360 A ² s
	$T_{VJ} = T_{VJM}$ $V_R = 0$	t = 10 ms (50 Hz), sine 1150 A ² s t = 8.3 ms (60 Hz), sine 1140 A ² s
T_{VJ}		-40...+150 °C
T_{VJM}		150 °C
T_{stg}		-40...+125 °C
V_{ISOL}	50/60 Hz, RMS t = 1 min	2500 V~
	$I_{ISOL} \leq 1 \text{ mA}$ t = 1 s	3000 V~
M_d	Mounting torque (M4)	1.5 - 2 Nm 14 - 18 lb.in.
Weight	typ.	18 g

Features

- Package with DCB ceramic base plate
- Isolation voltage 3000 V~
- Planar passivated chips
- Low forward voltage drop
- Leads suitable for PC board soldering
- UL registered E 72873

Applications

- Supplies for DC power equipment
- Input rectifiers for PWM inverter
- Battery DC power supplies
- Field supply for DC motors

Advantages

- Easy to mount with two screws
- Space and weight savings
- Improved temperature and power cycling capability
- Small and light weight

Symbol	Conditions	Characteristic Values
I_R	$V_R = V_{RRM}$ $T_{VJ} = 25^\circ\text{C}$	$\leq 0.5 \text{ mA}$
	$V_R = V_{RRM}$ $T_{VJ} = T_{VJM}$	$\leq 3 \text{ mA}$
V_F	$I_F = 80 \text{ A}$ $T_{VJ} = 25^\circ\text{C}$	$\leq 1.5 \text{ V}$
V_{T0}	For power-loss calculations only	0.8 V
r_T		7.5 mΩ
R_{thJC}	per diode; DC current	1.2 K/W
	per module	0.3 K/W
R_{thJH}	per diode; DC current	1.5 K/W
	per module	0.38 K/W
d_s	Creeping distance on surface	11.2 mm
d_A	Creepage distance in air	9.7 mm
a	Max. allowable acceleration	50 m/s ²

Data according to IEC 60747 refer to a single diode unless otherwise stated
 * for resistive load at bridge output

Dimensions in mm (1 mm = 0.0394")

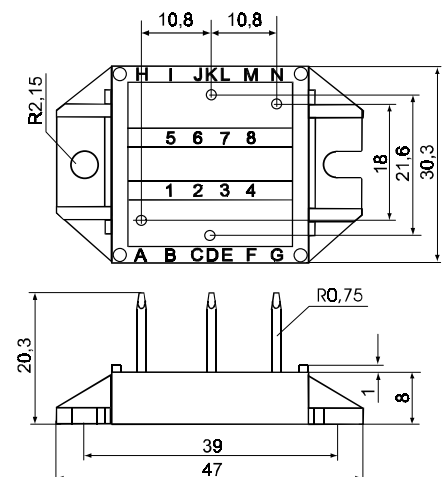

IXYS reserves the right to change limits, test conditions and dimensions.

20100706a