

# Three Phase Rectifier Bridge

$$I_{dAV} = 45 \text{ A}$$

$$V_{RRM} = 800-1800 \text{ V}$$

$V_{RSM/DSM}$ V	$V_{RRM/DRM}$ V	Type
900	800	VUO 34-08NO1
1300	1200	VUO 34-12NO1
1500	1400	VUO 34-14NO1
1700	1600	VUO 34-16NO1
1900	1800	VUO 34-18NO1

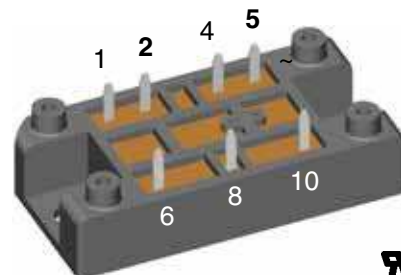
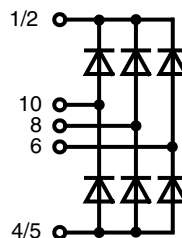

Symbol	Conditions	Maximum Ratings	
$I_{dAV}$	$T_C = 90^\circ\text{C}$ , module	36	A
$I_{dAV}$	$T_A = 45^\circ\text{C}$ ( $R_{thKA} = 0.5 \text{ K/W}$ ), module	37	A
$I_{dAVM}$	module	45	A
$I_{FSM}$	$T_{VJ} = 45^\circ\text{C}$ ; $t = 10 \text{ ms}$ (50 Hz)	300	A
	$V_R = 0$ ; $t = 8.3 \text{ ms}$ (60 Hz)	320	A
	$T_{VJ} = T_{VJM}$ ; $t = 10 \text{ ms}$ (50 Hz)	260	A
	$V_R = 0$ ; $t = 8.3 \text{ ms}$ (60 Hz)	280	A
$I^2t$	$T_{VJ} = 45^\circ\text{C}$ ; $t = 10 \text{ ms}$ (50 Hz)	450	A <sup>2</sup> s
	$V_R = 0$ ; $t = 8.3 \text{ ms}$ (60 Hz)	425	A <sup>2</sup> s
	$T_{VJ} = T_{VJM}$ ; $t = 10 \text{ ms}$ (50 Hz)	340	A <sup>2</sup> s
	$V_R = 0$ ; $t = 8.3 \text{ ms}$ (60 Hz)	325	A <sup>2</sup> s
$T_{VJ}$		-40...+130	°C
$T_{VJM}$		130	°C
$T_{stg}$		-40...+125	°C
$V_{ISOL}$	50/60 Hz, RMS $t = 1 \text{ min}$	3000	V~
	$I_{ISOL} \leq 1 \text{ mA}$ $t = 1 \text{ s}$	3600	V~
$M_d$	Mounting torque (M5) (10-32 UNF)	2 - 2.5	Nm
		18 - 22	lb.in.
<b>Weight</b>	Typ.	35	g

## Features

- Package with DCB ceramic base plate
- Isolation voltage 3600 V~
- Planar passivated chips
- Blocking voltage up to 1800 V
- Low forward voltage drop
- UL registered E 72873

## Applications

- Supplies for DC power equipment
- Input rectifiers for PWM inverter
- Battery DC power supplies
- Field supply for DC motors

## Advantages

- Easy to mount with one screw
- Space and weight savings
- Improved temperature & power cycling

Symbol	Conditions	Characteristic Values	
$I_R$	$V_R = V_{RRM}$ $T_{VJ} = 25^\circ\text{C}$	0.3	mA
		5.0	mA
$V_F$	$I_F = 55 \text{ A}$ $T_{VJ} = 25^\circ\text{C}$	1.51	V
$V_{T0}$	For power-loss calculations only	0.8	V
$r_t$		15	mΩ
$R_{thJH}$	per diode, 120° rect.	2.5	K/W
	per module, 120° rect.	0.42	K/W
$d_s$	Creeping distance on surface	12.7	mm
$d_A$	Creepage distance in air	9.4	mm
$a$	Max. allowable acceleration	50	m/s <sup>2</sup>

Data according to IEC 60747 and refer to a single diode unless otherwise stated.

IXYS reserves the right to change limits, test conditions and dimensions.

20100503a

© IXYS All rights reserved

1 - 3

Dimensions in mm (1 mm = 0.0394")

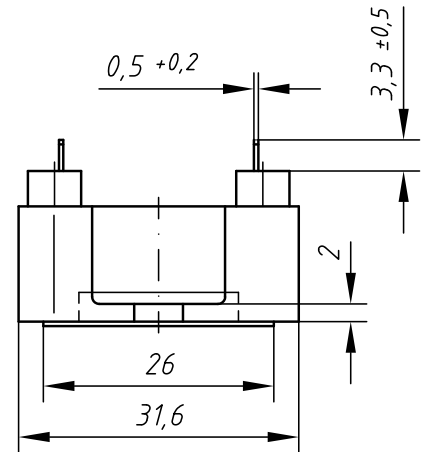
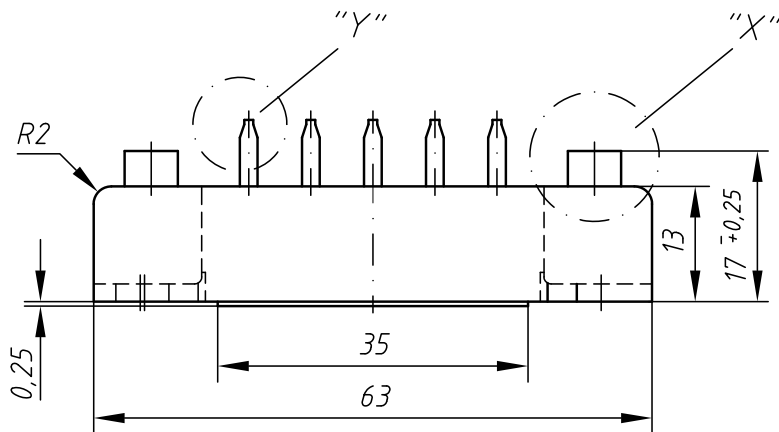

Detail "X" M 2:1

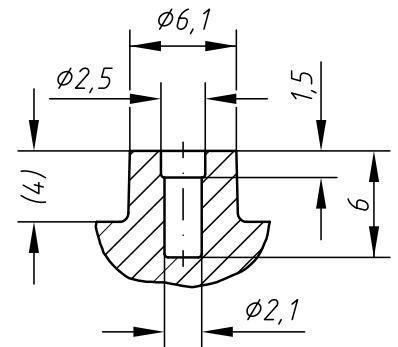
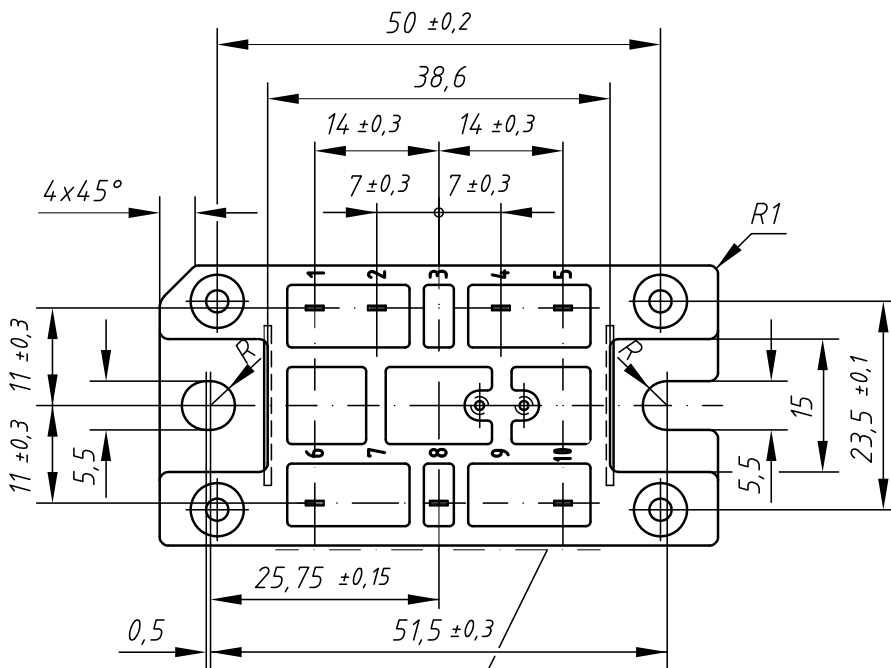

Detail "Y" M 5:1

Aufdruck der Typenbezeichnung  
Marking on Product

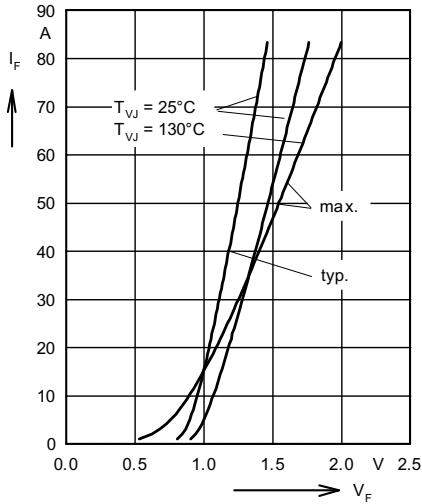

Fig. 1 Forward current versus voltage drop per diode

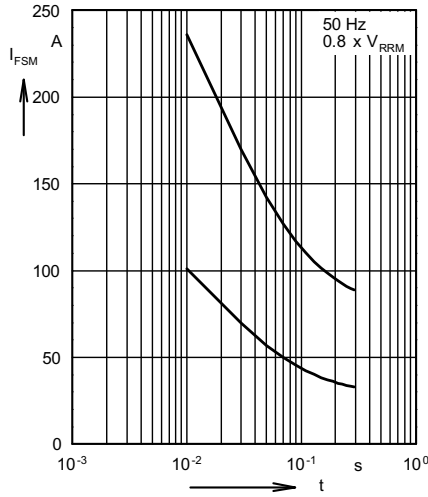

Fig. 2 Surge overload current per diode  $I_{FSM}$ : Crest value.  $t$ : duration

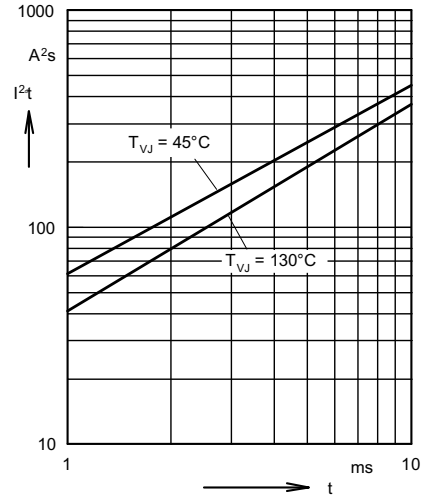

Fig. 3  $I^2t$  versus time (1-10 ms) per diode

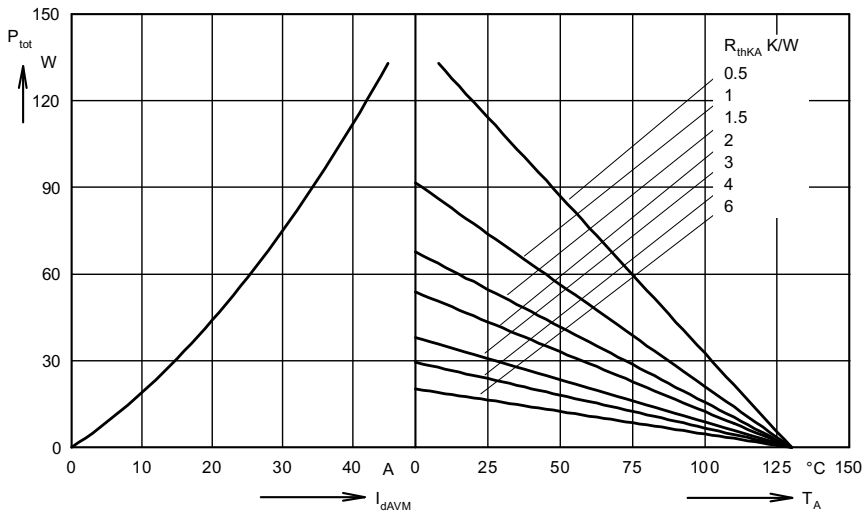

Fig. 4 Power dissipation versus direct output current and ambient temperature

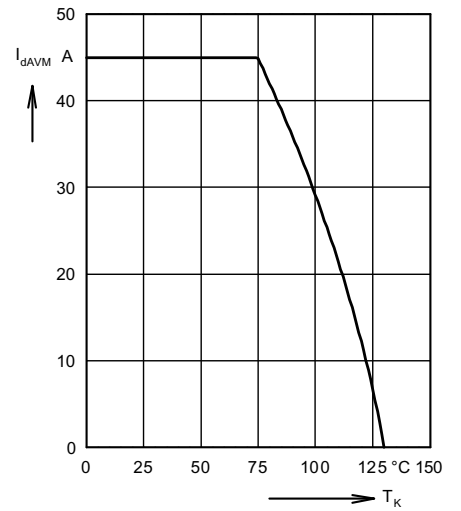

Fig. 5 Maximum forward current at case temperature

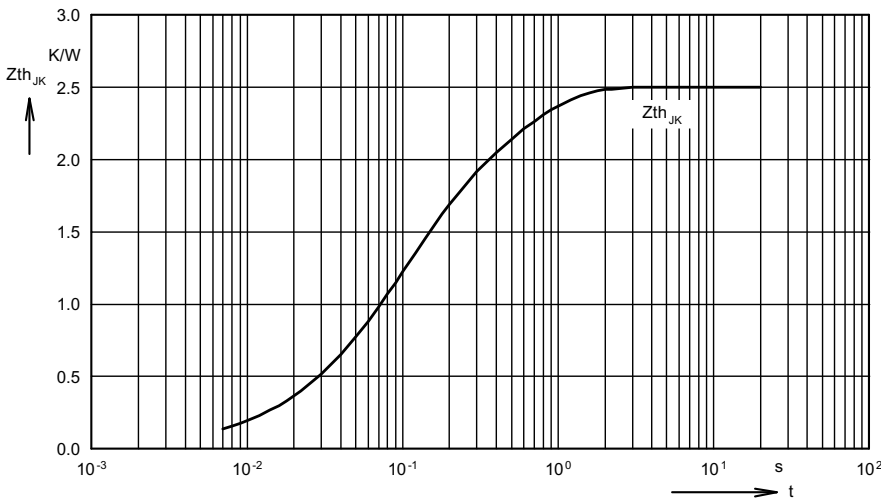

Fig. 6 Transient thermal impedance per diode

Constants for  $Z_{thJC}$  calculation:

$i$	$R_{thi}$ (K/W)	$t_i$ (s)
1	0.005	0.008
2	0.3	0.05
3	1.245	0.1
4	0.95	0.5