

Three Phase Rectifier Bridge

with IGBT and Fast Recovery Diode
for Braking System

Rectifier Diode	Fast Recov. Diode	IGBT
$V_{RRM} = 1200\text{ V}$ 1600 V	$V_{CES} = 1200\text{ V}$	$V_{CES} = 1200\text{ V}$
$I_{DAVM} = 188\text{ A}$	$V_F = 2.7\text{ V}$	$I_{C80} = 100\text{ A}$
$I_{FSM} = 1100\text{ A}$	$I_{FSM} = 200\text{ A}$	$V_{CEsat} = 2.1\text{ V}$

Preliminary data

Part name (Marking on product)

VUB120-12NO2(T)

VUB120-16NO2(T)

(T) = NTC optional

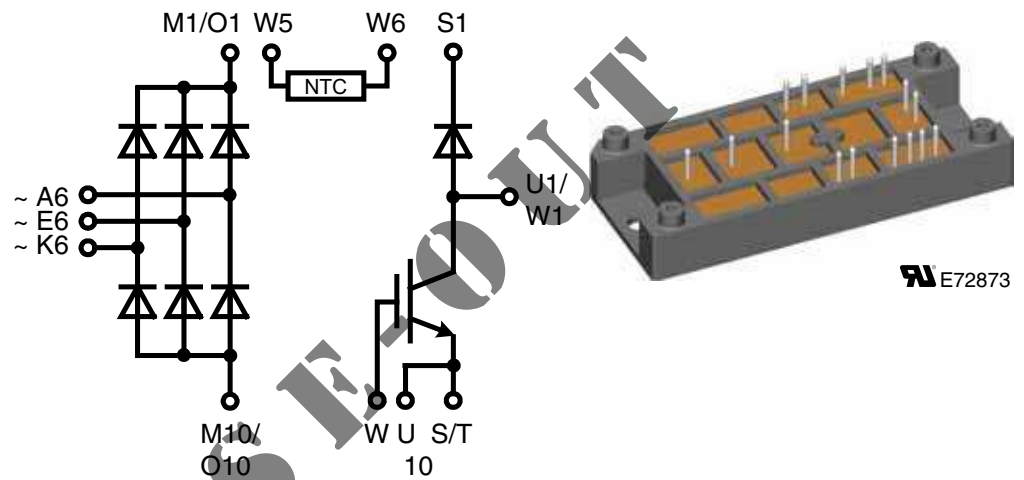

Features:

- Soldering connections for PCB mounting
- Isolation voltage 3600 V~
- Ultrafast diode
- Convenient package outline
- Optional NTC

Application:

- Drive Inverters with brake system

Package:

- Two functions in one package
- Easy to mount with two screws
- Suitable for wave soldering
- High temperature and power cycling capability
- UL registered, E72873

Recommended replacement: VUB120-16NOX(T)

IGBT						
Symbol	Definitions	Conditions	Ratings			
			min.	typ.	max.	Unit
V_{CES}	collector emitter voltage	$T_{VJ} = 25^{\circ}\text{C}$ to 150°C			1200	V
V_{GES}	max. DC gate voltage	continuous	-20		+20	V
V_{GEM}	max. transient collector gate voltage	transient	-30		+30	V
I_{C25}	collector current	DC	$T_C = 25^{\circ}\text{C}$		140	A
I_{C80}		DC	$T_C = 80^{\circ}\text{C}$		100	A
P_{tot}	total power dissipation		$T_C = 25^{\circ}\text{C}$		140	W
$V_{CE(sat)}$	collector emitter saturation voltage	$I_C = 50\text{ A}; V_{GE} = 15\text{ V}$	$T_{VJ} = 25^{\circ}\text{C}$		2.1	V
$V_{GE(th)}$	gate emitter threshold voltage	$I_C = 4\text{ mA}; V_{GE} = V_{CE}$	$T_{VJ} = 25^{\circ}\text{C}$	4.5	6.5	V
I_{CES}	collector emitter leakage current	$V_{CE} = V_{CES}; V_{GE} = 0\text{ V}$	$T_{VJ} = 25^{\circ}\text{C}$ $T_{VJ} = 125^{\circ}\text{C}$		0.2 1	mA mA
C_{ies}	input capacitance	$V_{CE} = 25\text{ V}; V_{GE} = 0\text{ V}; f = 1\text{ MHz}$		7.4		nF
$t_{d(on)}$	turn-on delay time	inductive load $V_{CE} = 600\text{ V}; I_C = 50\text{ A}$ $V_{GE} = \pm 15\text{ V}; R_G = 15\ \Omega; L = 100\ \mu\text{H}$	$T_{VJ} = 125^{\circ}\text{C}$	170		ns
$t_{d(off)}$	turn-off delay time			680		ns
E_{on}	turn-on energy per pulse			11		mJ
E_{off}	turn-off energy per pulse			8		mJ
I_{CM}	reverse bias safe operating area	RBSOA; $V_{GE} = \pm 15\text{ V}; R_G = 10\ \Omega; L = 100\ \mu\text{H}$	$T_{VJ} = 125^{\circ}\text{C}$	280		A
V_{CEK}	reverse bias safe operating area	clamped inductive load;	$T_{VJ} = 125^{\circ}\text{C}$	$\leq V_{CES} - L_S \cdot di/dt$		V
t_{SC} (SCSOA)	short circuit safe operating area	$V_{CE} = 900\text{ V}; V_{GE} = \pm 15\text{ V};$ $R_G = 15\ \Omega;$ non-repetitive	$T_{VJ} = 125^{\circ}\text{C}$		10	μs
RBSOA	reverse bias safe operating area	$V_{CE} = 1200\text{ V}; V_{GE} = \pm 15\text{ V};$ $R_G = 15\ \Omega; L = 100\ \mu\text{H};$ clamped inductive load	$T_{VJ} = 125^{\circ}\text{C}$		150	A
R_{thJC}	thermal resistance junction to case				0.22	K/W
R_{thCH}	thermal resistance case to heatsink			0.1		K/W

Fast Recovery Diode						
Symbol	Definitions	Conditions	Ratings			
			min.	typ.	max.	Unit
V_{RRM}	max. repetitive reverse voltage	$T_{VJ} = 150^{\circ}\text{C}$			1200	V
I_{FAV}	average forward current	rect.; $d = 0.5$	$T_C = 80^{\circ}\text{C}$		34	A
I_{FRMS}	rms forward current	rect.; $d = 0.5$	$T_C = 80^{\circ}\text{C}$		48	A
I_{FSM}	max. surge forward current	$t = 10\text{ ms}$	$T_{VJ} = 45^{\circ}\text{C}$		200	A
		$t = 10\text{ ms}$	$T_{VJ} = 150^{\circ}\text{C}$		180	A
P_{tot}	total power dissipation		$T_C = 25^{\circ}\text{C}$		140	W
V_{F0}	threshold voltage		$T_{VJ} = 150^{\circ}\text{C}$		1.3	V
r_F	slope resistance	for power loss calculation only			15	$\text{m}\Omega$
V_F	forward voltage	$I_F = 30\text{ A}$	$T_{VJ} = 25^{\circ}\text{C}$		2.7	V
I_R	reverse current	$V_R = V_{RRM}$	$T_{VJ} = 25^{\circ}\text{C}$ $T_{VJ} = 125^{\circ}\text{C}$		0.5 1	mA mA
I_{RM}	reverse recovery current	$I_F = 50\text{ A}; V_R = 100\text{ V}; di_F/dt = -100\text{ A}/\mu\text{s}$		8	12	A
t_{rr}	reverse recovery time	$I_F = 1\text{ A}; V_R = 30\text{ V}; di_F/dt = -100\text{ A}/\mu\text{s}$		40	60	ns
R_{thJC}	thermal resistance junction to case				0.9	K/W
R_{thCH}	thermal resistance case to heatsink			0.3		K/W

 $T_C = 25^{\circ}\text{C}$ unless otherwise stated

Rectifier Diode

Symbol	Conditions	Ratings			Unit
		min.	typ.	max.	
V_{RRM}	max. repetitive reverse voltage	$T_{VJ} = 25^{\circ}\text{C}$		1200 1600	V V
I_R	reverse current	$V_R = V_{RRM}$	$T_{VJ} = 25^{\circ}\text{C}$ $T_{VJ} = 150^{\circ}\text{C}$	0.3 5	mA mA
V_F	forward voltage	$I_F = 150\text{ A}$	$T_{VJ} = 25^{\circ}\text{C}$	1.46	V
$I_{D(AV)M}$	max. average DC output current	rectangular; $d = 1/3$; bridge	$T_C = 80^{\circ}\text{C}$	188	A
V_{F0}	threshold voltage		$T_{VJ} = 150^{\circ}\text{C}$	0.87	V
r_F	slope resistance	for power loss calculation only		4	m Ω
R_{thJC}	thermal resistance junction to case	per diode	$T_{VJ} = 25^{\circ}\text{C}$	0.6	K/W
R_{thCH}	thermal resistance case to heatsink		$T_{VJ} = 25^{\circ}\text{C}$	0.2	K/W
P_{tot}	total power dissipation		$T_{VJ} = 25^{\circ}\text{C}$	160	W
I_{FSM}	max. forward surge current	$t = 10\text{ ms (50Hz)}$ $V_R = 0\text{ V}$	$T_{VJ} = 45^{\circ}\text{C}$ $T_{VJ} = 150^{\circ}\text{C}$	1100 960	A A
I^2t	value for fusing	$t = 10\text{ ms (50Hz)}$ $V_R = 0\text{ V}$	$T_{VJ} = 45^{\circ}\text{C}$ $T_{VJ} = 150^{\circ}\text{C}$	6050 4610	A ² s A ² s

Temperature Sensor NTC

Symbol	Definitions	Conditions	Ratings			Unit
			min.	typ.	max.	
R_{25}	resistance	$T_C = 25^{\circ}\text{C}$	4.75	5.0	5.25	k Ω
$B_{25/85}$				3375		K

Module

Symbol	Definitions	Conditions	Ratings			Unit
			min.	typ.	max.	
T_{VJ}	operating temperature		-40		150	$^{\circ}\text{C}$
T_{VJM}	max. virtual junction temperature				150	$^{\circ}\text{C}$
T_{stg}	storage temperature		-40		125	$^{\circ}\text{C}$
V_{ISOL}	isolation voltage	$I_{ISOL} \leq 1\text{ mA}; 50/60\text{ Hz};$ $t = 1\text{ min.}$ $t = 1\text{ s}$			3000 3600	V~ V~
M_d	mounting torque	(M5)	2.0		2.5	Nm
d_s	creep distance on surface		12.7			mm
d_A	strike distance through air		9.4			mm
a	maximum allowable acceleration		50			m/s ²
Weight				80		g

 $T_C = 25^{\circ}\text{C}$ unless otherwise stated

Outline Drawing

Dimensions in mm (1 mm = 0.0394")

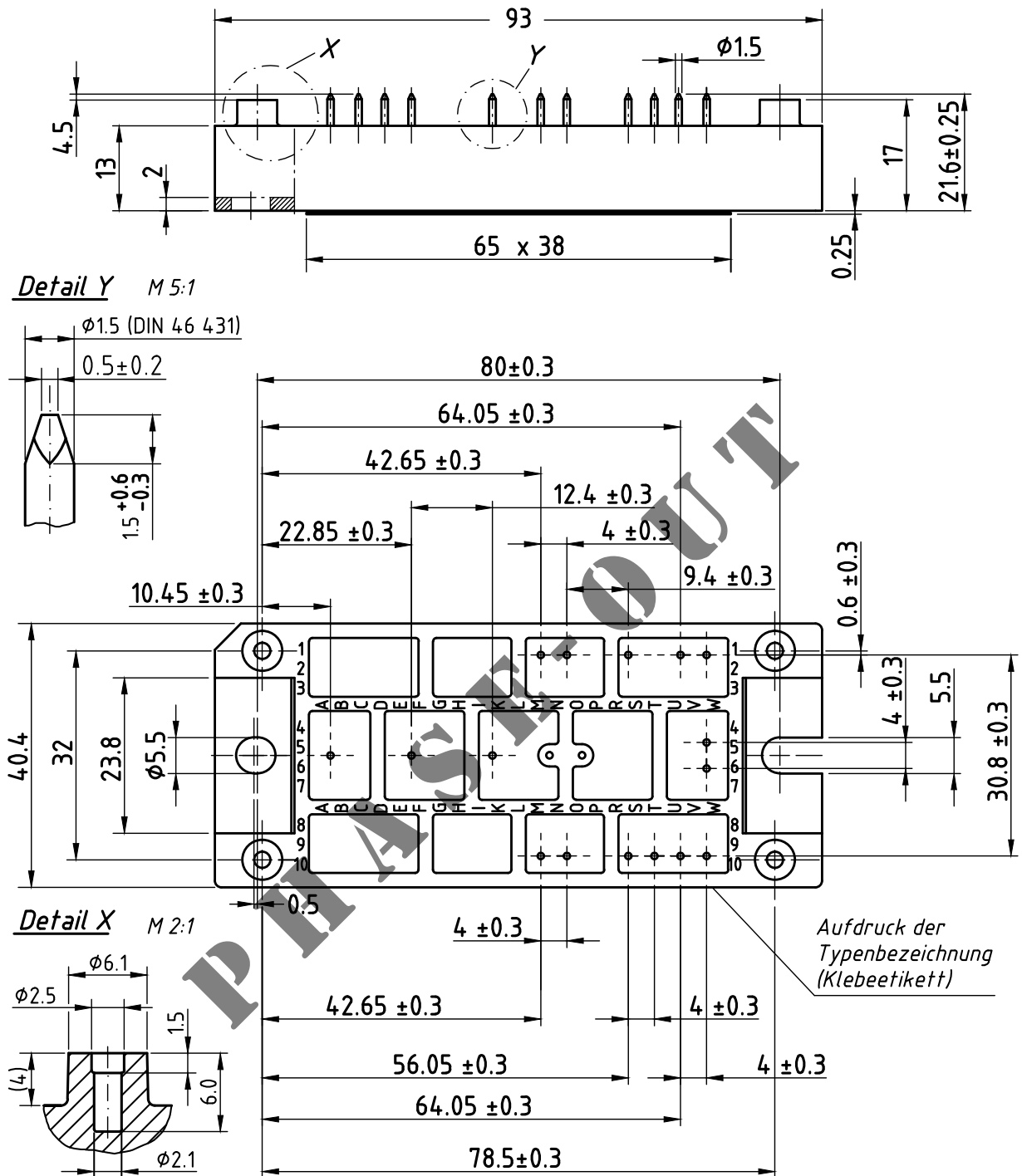

Product Marking

Ordering	Part Name	Marking on Product	Delivering Mode	Base Qty	Ordering Code
Standard	VUB 120-12NO2	VUB120-12NO2	Box	6	495956
Standard	VUB 120-16NO2	VUB120-16NO2	Box	6	495964
+NTC	VUB 120-12NO2T	VUB120-12NO2	Box	6	499592
+NTC	VUB 120-16NO2T	VUB120-16NO2	Box	6	499714