

General Description

The MIC2776 is a power supply supervisor which provides under-voltage monitoring and power-on reset generation in a compact 5-pin SOT package. Features include an adjustable under-voltage detector, a delay-generator, a manual reset input, and a choice of active-high, active-low, or open-drain active-low reset output. The user-adjustable monitoring input is compared against a 300mV reference. This low reference voltage allows monitoring voltages lower than those supported by previous supervisor ICs.

The reset output is asserted for no less than 140ms at power-on and any time the input voltage drops below the reference voltage. It remains asserted for the timeout period after the input voltage subsequently rises back above the threshold boundary. A reset can be generated at any time by asserting the manual reset input, /MR. The reset output will remain active at least 140ms after the release of /MR. The /MR input can also be used to daisy-chain the MIC2776 onto existing power monitoring circuitry or other supervisors. Hysteresis is included to prevent chattering due to noise. Typical supply current is a low 3.0µA.

Features

- User-adjustable input can monitor supplies as low as 0.3V
- ±1.5% threshold accuracy
- Separate V_{DD} input
- Generates power-on reset pulse (140ms min.)
- Manual reset input
- Choice of active-high, active-low or open-drain active-low reset output
- Inputs can be pulled above V_{DD} (7V abs. max.)
- Open-drain output can be pulled above V_{DD} (7V abs. max.)
- Ultra-low supply current, 3.0µA typical
- Rejects brief input transients
- IttyBitty™ SOT-23-5 package

Applications

- Monitoring processor, ASIC, or FPGA core voltage
- Computer systems
- PDAs/Hand-held PCs
- Embedded controllers
- Telecommunications systems
- Power supplies
- Wireless / cellular systems
- Networking hardware

Typical Application

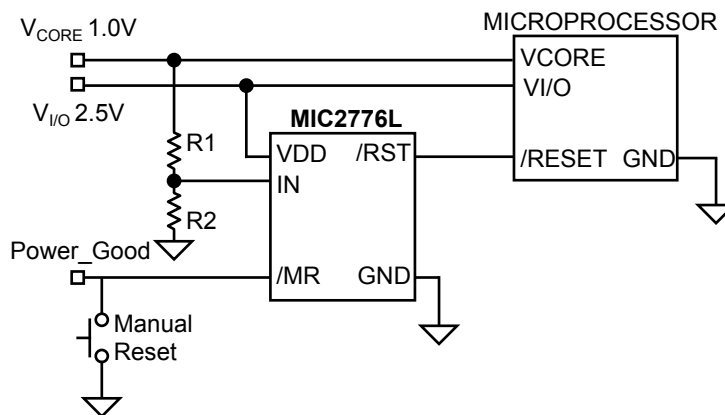

Ordering Information

Part Number				Reset Output	Temperature Range	Package
Standard	Marking	Pb-Free	Marking			
MIC2776N-BM5	UKAA	MIC2776N-YM5	<u>UKAA</u>	Open-Drain, Active-Low / RST	-40°C to +85°C	SOT-23-5
MIC2776H-BM5	ULAA	MIC2776H-YM5	<u>ULAA</u>	Active-High, Complementary RST	-40°C to +85°C	SOT-23-5
MIC2776L-BM5	UMAA	MIC2776L-YM5	<u>UMAA</u>	Active-Low, Complementary /RST	-40°C to +85°C	SOT-23-5

Pin Configuration

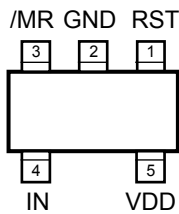

SOT-23-5 (M5)
“H” Version

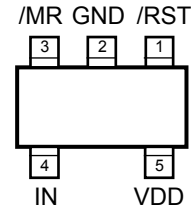

SOT-23-5 (M5)
“L” and “N” Version

Pin Description

Pin Number MIC2776H	Pin Number MIC2776L MIC2776N	Pin Name	Pin Function
1		RST	Digital (Output): Asserted high whenever V_{IN} falls below the reference voltage. It will remain asserted for no less than 140ms after V_{IN} returns above the threshold limit.
	1	/RST	Digital (Output): Asserted low whenever V_{IN} falls below the reference voltage. It will remain asserted for no less than 140ms after V_{IN} returns above the threshold limit. (open-drain for “N” version)
2	2	GND	Ground
3	3	/MR	Digital (Input): Driving this pin low initiates an immediate and unconditional reset. Assuming IN is above the threshold when /MR is released (returns high), the reset output will be de-asserted no less than 140ms later. /MR may be driven by a logic signal or a mechanical switch. /MR has an internal pull-up to V_{DD} and may be left open if unused.
4	4	IN	Analog (Input): The voltage on this pin is compared to the internal 300mV reference. An under-voltage condition will trigger a reset sequence.
5	5	VDD	Analog (Input): Independent supply input for internal circuitry.

Absolute Maximum Ratings (Note 1)

Supply Voltage (V_{DD})	-0.3V to +7V
Input Voltages (V_{IN} , $V_{/MR}$)	-0.3V to +7V
RST, (/RST) Current	20mA
Storage Temperature (T_S)	-65°C to +150°C
ESD Rating, Note 3	1.5kV

Operating Ratings (Note 2)

Supply Voltage (V_{DD})	+1.5V to +5.5V
Input Voltages (V_{IN} , $V_{/MR}$)	-0.3V to +6.0V
Output Voltages	
$V_{/RST}$ (N version)	-0.3V to +6.0V
$V_{/RST}$, V_{RST} (H and L versions)	-0.3V to $V_{DD} + 0.3V$
Ambient Temperature Range (T_A)	-40°C to +85°C
Package Thermal Resistance (θ_{JA})	256°C/W

Electrical Characteristics

$V_{DD} = 3.3V$; $T_A = +25^\circ C$, **bold** values indicate $-40^\circ C \leq T_A \leq +85^\circ C$; unless noted

Symbol	Parameter	Condition	Min	Typ	Max	Units
I_{DD}	Supply Current	$V_{DD} = V_{IN} = 3.3V$; /MR, RST, /RST open		3.0		μA

IN, UNDER-VOLTAGE DETECTOR INPUT

V_{REF}	Under-Voltage Threshold	$T_A = 25^\circ C$	295	300	305	mV
V_{HYST}	Hysteresis Voltage			3		mv
I_{IN}	Input Current			5		pA
		$T_{MIN} \leq T_A \leq T_{MAX}$			10	nA

RESET OUTPUTS (/RST, RST)

t_{PROP}	Propagation Delay	$V_{IN} = (V_{REF(MAX)} + 100mV)$ to $V_{IN} = (V_{REF(MIN)} - 100mV)$		20		μs
t_{RST}	Reset Pulse Width		140		280	ms
V_{OL}	RST or /RST Output Voltage Low	$I_{SINK} = 1.6mA$; $V_{DD} \geq 1.6V$			0.3	V
		$I_{SINK} = 100\mu A$; $V_{DD} \geq 1.2V$, Note 4			0.3	V
V_{OH}	RST or /RST Output Voltage High (H and L Version Only)	$I_{SOURCE} = 500\mu A$; $V_{DD} \geq 1.5V$	0.8	V_{DD}		V
		$I_{SOURCE} = 10\mu A$; $V_{DD} \geq 1.2V$, Note 4	0.8	V_{DD}		V

MANUAL RESET INPUTS (/MR)

V_{IH}	Input High Voltage	$1.5V \leq V_{DD} \leq 5.5V$	0.7	V_{DD}		V
V_{IL}	Input Low Voltage	$1.5V \leq V_{DD} \leq 5.5V$			0.3	V_{DD} V
t_{PROP}	Propagation Delay	$V_{/MR} < V_{IL}$		5		μs
t_{MIN}	Minimum Input Pulse Width	Reset Occurs, $V_{/MR} < V_{IL}$		33		ns
I_{PU}	Internal Pull-Up Current			100		nA
I_{IN}	Input Current, /MR	$V_{/MR} < V_{IL}$		100		nA

Note 1. Exceeding the absolute maximum rating may damage the device.

Note 2. The device is not guaranteed to function outside its operating rating.

Note 3. Devices are ESD sensitive. Handling precautions recommended. Human body model, 1.5k in series with 100pF.

Note 4. V_{DD} operating range is 1.5V to 5.5V. Output is guaranteed to be asserted down to $V_{DD} = 1.2V$.

Timing Diagram

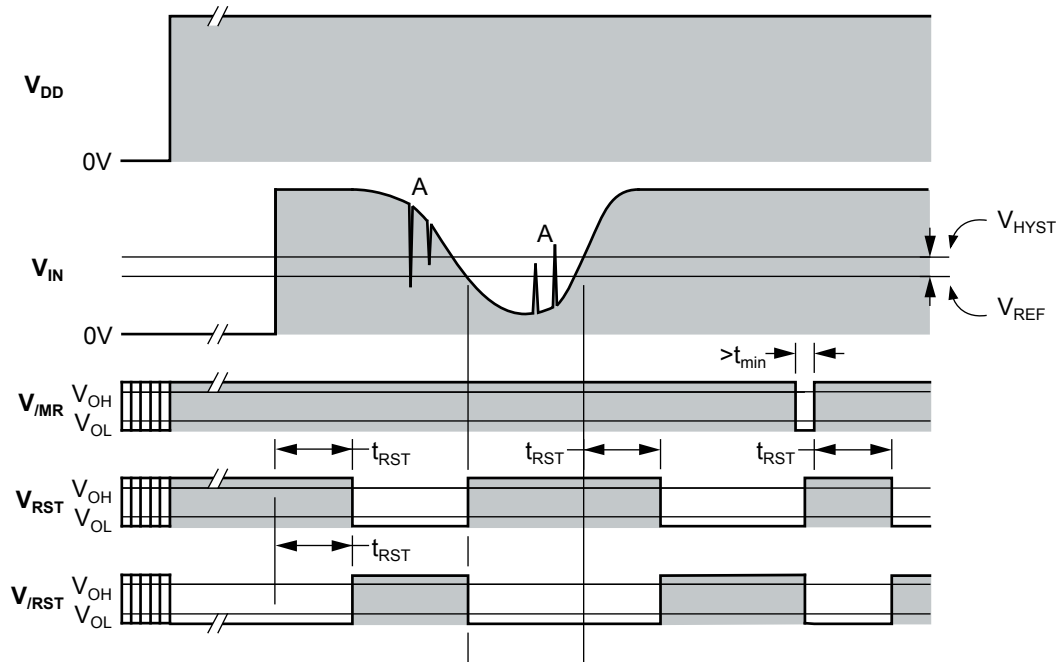

Propagation delays not shown for clarity.

Note A. The MIC2776 ignores very brief transients. See "Applications Information" for details.

Functional Diagram

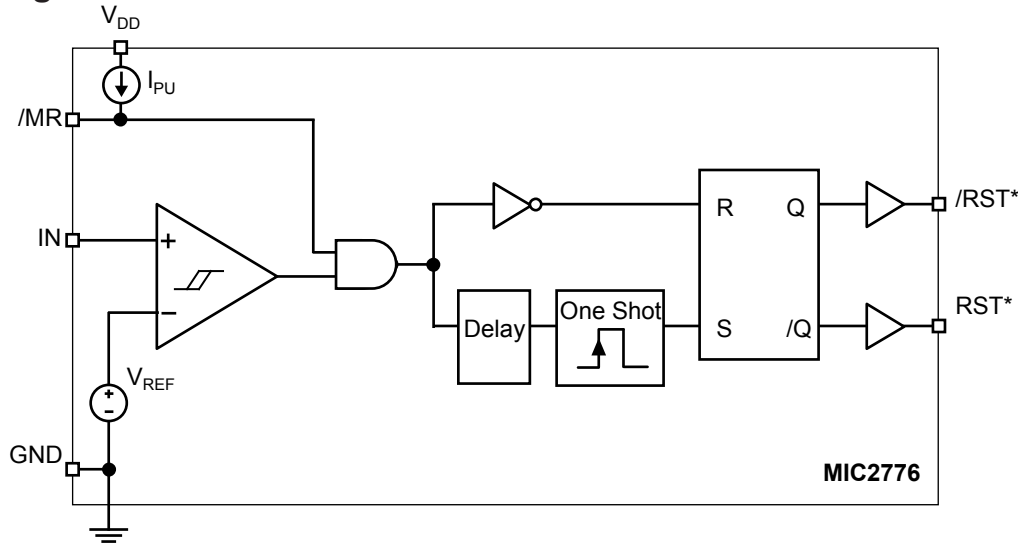

* Pinout and polarity vary by device type.
See ordering information table.

Functional Description

IN, Under-Voltage Detector Input

The voltage present at the IN pin is compared to the internal 300mV reference voltage. A reset is triggered if and when V_{IN} falls below V_{REF} . Typically, a resistor divider is used to scale the input voltage to be monitored such that V_{IN} will fall below V_{REF} as the voltage being monitored falls below the desired trip-point. Hysteresis is employed to prevent chattering due to noise.

RST, /RST Reset Output

Typically, the MIC2776 is used to monitor the power supply of intelligent circuits such as microcontrollers and microprocessors. By connecting the reset output of a MIC2776 to the reset input of a μC or μP , the processor will be properly reset at power-on and during power-down and brown-out conditions. In addition, asserting /MR, the manual reset input, will activate the reset function.

The reset outputs are asserted any time /MR is asserted or if V_{IN} drops below the threshold voltage. The reset outputs remain asserted for $t_{RST}(\text{min})$ after V_{IN} subsequently returns above the threshold boundary and /MR is released. A reset pulse is also generated at power-on.

/MR, Manual Reset Input

The ability to initiate a reset via external logic or a manual switch is provided in addition to the MIC2776's automatic supervisory functions. Driving the /MR input to a logic low causes an immediate and unconditional reset to occur. Assuming V_{IN} is within tolerance when /MR is released (returns high), the reset output will be de-asserted no less than t_{RST} later. /MR may be driven by a logic signal, or mechanical switch. Typically, a momentary push-button switch is connected such that /MR is shorted to ground when the switch contacts close. The switch may be connected directly between /MR and GND. /MR has an internal 100nA pull-up current to V_{DD} and may be left open if unused.

Application Information

Programming the Voltage Threshold

Referring to the “Typical Application Circuit”, the voltage threshold is calculated as follows:

$$V_{TH} = V_{REF} \times \frac{(R1+R2)}{R2}$$

$$\text{where } V_{REF} = 0.300V$$

In order to provide the additional criteria needed to solve for the resistor values, the resistors can be selected such that the two resistors have a given total value, that is, $R1 + R2 = R_{TOTAL}$. Imposing this condition on the resistor values provides two equations that can be solved for the two unknown resistor values. A value such as $1M\Omega$ for R_{TOTAL} is a reasonable choice since it keeps quiescent current to a generally acceptable level while not causing any measurable errors due to input bias currents. The larger the resistors, the larger the potential errors due to input bias current (I_{IN}). The maximum recommended value of R_{TOTAL} is $3M\Omega$.

Applying this criteria and rearranging the V_{TH} expression to solve for the resistor values gives:

$$R2 = \frac{(R_{TOTAL} \times V_{REF})}{V_{TH}}$$

$$R1 = R_{TOTAL} - R2$$

Application Example

Figure 1 below illustrates a hypothetical MIC2776 application in which the MIC2776 is used to monitor the core supply of a high-performance CPU or DSP. The core supply, V_{CORE} , in this example is $1.0V \pm 5\%$. The main power rail and I/O voltage, $V_{I/O}$, is $2.5V \pm 5\%$. As shown in Figure 1, the MIC2776 is powered by $V_{I/O}$. The minimum value of $V_{I/O}$ is $2.5V - 5\% = 2.375V$; the maximum is $2.5V + 5\% = 2.625V$. This is well within the MIC2776's power supply range of 1.5V to 5.5V.

Resistors R1 and R2 must be selected to correspond to the V_{CORE} supply of 1.0V. The goal is to insure that the core supply voltage is adequate to insure proper operation, i.e., $V_{CORE} \geq (1.0V - 5\%) = 0.950V$. Because there is always a small degree of uncertainty due to the accuracy of the resistors, variations in the devices' voltage reference, etc., the threshold will be set slightly below this value. The potential variation in the MIC2776's voltage reference is specified as $\pm 1.5\%$. The resistors chosen will have their own tolerance specification. This example will assume the use of 1% accurate resistors. The potential worst-case error contribution due to input bias current can be calculated once the resistor values are chosen. If the guidelines above regarding the maximum total value of $R1+R2$ are followed, this error contribution will be very small thanks to the MIC2776's very low input bias current.

To summarize, the various potential error sources are:

- Variation in V_{REF} : specified at $\pm 1.5\%$
- Resistor tolerance: chosen by designer (typically $\leq \pm 1\%$)
- Input bias current, I_{IN} : calculated once resistor values are known, typically very small

Taking the various potential error sources into account, the threshold voltage will be set slightly below the minimum V_{CORE} specification of 0.950V so that when the actual threshold voltage is at its maximum, it will not intrude into the normal operating range of V_{CORE} . The target threshold voltage will be set as follows:

Given that the total tolerance on V_{TH} is $[V_{REF} \text{ tolerance}] + [\text{resistor tolerance}]$

$$= \pm 1.5\% + \pm 1\% = \pm 2.5\%,$$

$$\text{and } V_{TH(max)} = V_{CORE(min)},$$

$$\text{then } V_{CORE(min)} = V_{TH} + 2.5\% V_{TH} = 1.025 V_{TH},$$

therefore, solving for V_{TH} results in

$$V_{TH} = \frac{V_{CORE(min)}}{1.025} = \frac{0.950}{1.025} = 0.9268V$$

Solving for R1 and R2 using this value for V_{TH} and the equations above yields:

$$R1 = 676.3k\Omega \approx 673k\Omega$$

$$R2 = 323.7k\Omega \approx 324k\Omega$$

The resulting circuit is shown in Figure 1.

Input Bias Current Effects

Now that the resistor values are known, it is possible to calculate the maximum potential error due to input bias current, I_{IN} . As shown in the “Electrical Characteristics” table, the maximum value of I_{IN} is 10nA. (Note that the typical value is a much smaller 5pA!) The magnitude of the offset caused by I_{IN} is given by:

$$V_{ERROR} = I_{IN(max)} \times (R1 || R2) =$$

$$V_{ERROR} = \pm 1 \times 10^{-8}A \times 2.189 \times 10^5\Omega =$$

$$V_{ERROR} = \pm 2.189 \times 10^{-3}V =$$

$$V_{ERROR} = \pm 2.189mV$$

The typical error is about three orders of magnitude lower than this - close to one microvolt! Generally, the error due to input bias can be discounted. If it is to be taken into account, simply adjust the target threshold voltage downward by this amount and recalculate R1 and R2. The resulting value will be very close to optimum. If accuracy is more important than the quiescent current in the resistors, simply reduce the value of R_{TOTAL} to minimize offset errors.

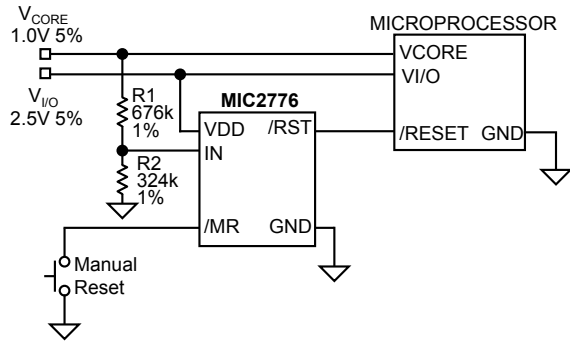

Figure 1. MIC2776 Example Design

Interfacing to Processors With Bidirectional Reset Pins

Some microprocessors have reset signal pins that are bi-directional, rather than input only. The Motorola 68HC11 family is one example. Because the MIC2776N's output is open-drain, it can be connected directly to the processor's reset pin using only the pull-up resistor normally required. See Figure 2.

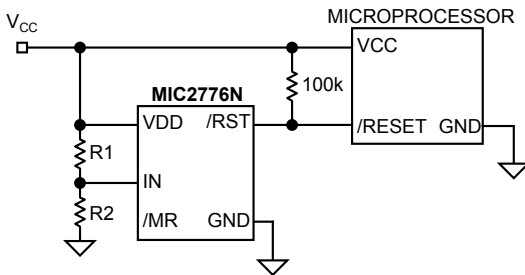

Figure 2. Interfacing to Bidirectional Reset Pin

Transient Response

The MIC2776 is inherently immune to very short negative-going "glitches." Very brief transients may exceed the voltage threshold without tripping the output.

As shown in Figure 3, the narrower the transient, the deeper the threshold overdrive that will be ignored by the MIC2776. The graph represents the typical allowable transient duration for a given amount of threshold overdrive that will not generate a reset.

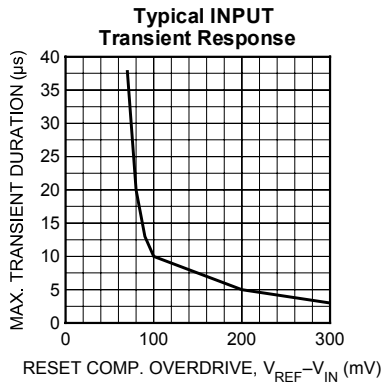

Figure 3. Typical INPUT Transient Response

Ensuring Proper Operation at Low Supply

At levels of V_{DD} below 1.2V, the MIC2776L's /RST output driver cannot turn on sufficiently to produce a valid logic-low on the /RST output. In this situation, other circuits driven by /RST could be allowed to float, causing undesired operation. (In most cases, however, it is expected that the circuits driven by the MIC2776L will be similarly inoperative at $V_{DD} \leq 1.2V$.)

If a given application requires that /RST be valid below $V_{DD} = 1.2V$, this can be accomplished by adding a pull-down resistor to the /RST output. A value of 100kΩ is recommended as this is usually an acceptable compromise of leakage current and pull-down current. The resistor's value is not critical, however. See Figure 4.

The statements above also apply to the MIC2776H's RST output. That is, to ensure valid RST signal levels at $V_{DD} < 1.2V$, a pull-up resistor (as opposed to a pull-down) should be added to the RST output. A value of 100kΩ is typical for this application as well. See Figure 5.

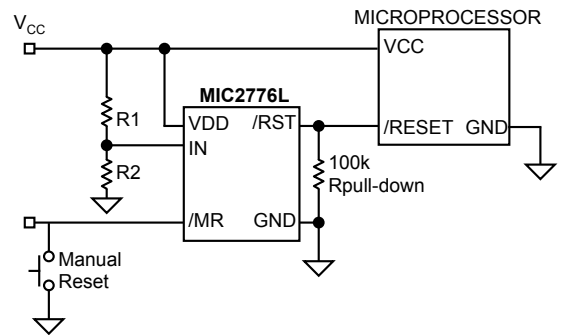

Figure 4. MIC2776L Valid /Reset Below 1.2V

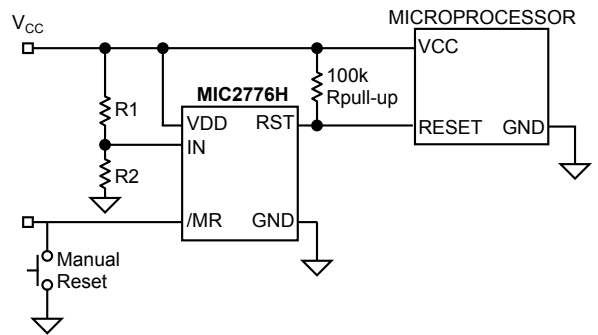
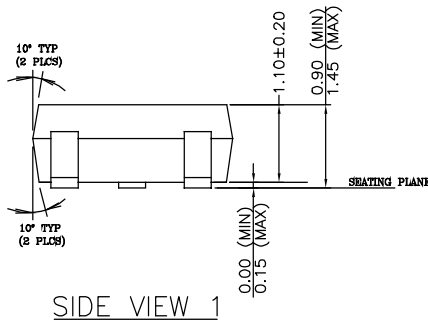
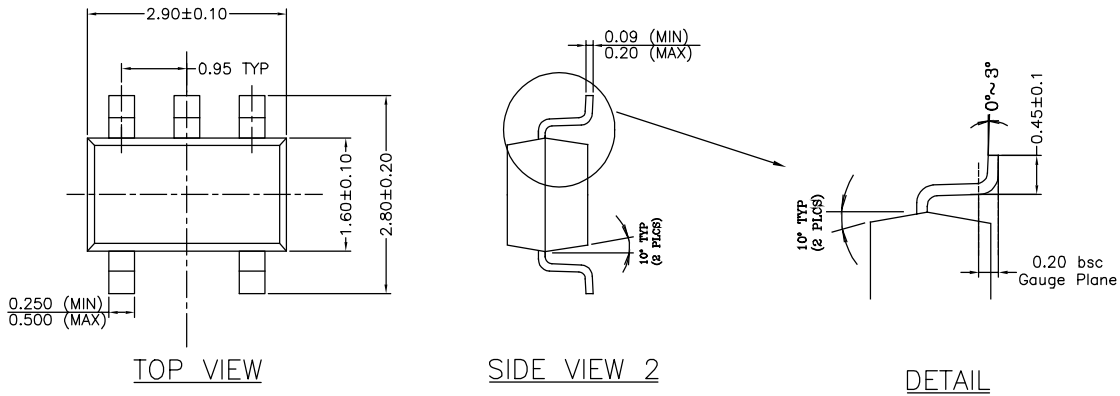

Figure 5. MIC2776H Valid Reset Below 1.2V

Package Information



- NOTE:
1. PACKAGE OUTLINE EXCLUSIVE OF MOLD FLASH & BURR.
 2. PACKAGE OUTLINE INCLUSIVE OF SOLER PLATING.
 3. DIMENSION AND TOLERANCE PER ANSI Y14.5M, 1982.
 4. FOOT LENGTH MEASUREMENT BASED ON GAUGE PLANE METHOD.
 5. DIE FACES UP FOR MOLD, AND FACES DOWN FOR TRIM/FORM.

SOT-23-5 (M5)

MICREL INC. 2180 FORTUNE DRIVE SAN JOSE, CA 95131 USA
 TEL + 1 (408) 944-0800 FAX + 1 (408) 474-1000 WEB <http://www.micrel.com>

This information furnished by Micrel in this data sheet is believed to be accurate and reliable. However no responsibility is assumed by Micrel for its use. Micrel reserves the right to change circuitry and specifications at any time without notification to the customer.

Micrel Products are not designed or authorized for use as components in life support appliances, devices or systems where malfunction of a product can reasonably be expected to result in personal injury. Life support devices or systems are devices or systems that (a) are intended for surgical implant into the body or (b) support or sustain life, and whose failure to perform can be reasonably expected to result in a significant injury to the user. A Purchaser's use or sale of Micrel Products for use in life support appliances, devices or systems is a Purchaser's own risk and Purchaser agrees to fully indemnify Micrel for any damages resulting from such use or sale.