

- 3.0V to 3.8V power supply option
- Guaranteed AC parameters over temperature:
 - $f_{MAX} = 800\text{MHz}$
 - $< 200\text{ps}$ differential propagation delay (D to Q_{FB})
 - $< 730\text{ps}$ differential propagation delay (D to Q_{HG})
 - $< 250\text{ps}$ t_r / t_f
- Low-gain feedback path $Q_{FB} = +10\text{V/V}$
- V_{BB} reference output voltage
- Wide temperature range: -40°C to $+85^\circ\text{C}$
- Available in 10-pin (3mm x 3mm) MSOP
- LVPECL/LVECL/CMOS compatible EN option



Precision Edge®

DESCRIPTION

The SY89207L is a differential receiver amplifier optimized for crystal oscillator applications. The device includes an additional low differential gain (+10V/V) output stage (Q_{FB}) ideal for feedback applications common in crystal oscillator gain blocks. The SY89207L is fully differential, with a bandwidth $> 800\text{MHz}$ over temperature and voltage. For applications that require output disable control, a LVPECL/LVECL/CMOS compatible enable pin (EN) will force the differential output into a fixed logic state. The SY89207L also includes a V_{BB} reference voltage for single-ended or AC-coupled applications.

The SY89207L PECL logic is 100k ECL compatible. Operation is guaranteed over the -40°C to $+85^\circ\text{C}$ temperature range and 3.3V nominal supply voltage range.

All support documentation can be found on Micrel's web site at www.micrel.com.

APPLICATIONS

- Oscillator timing modules

BLOCK DIAGRAM

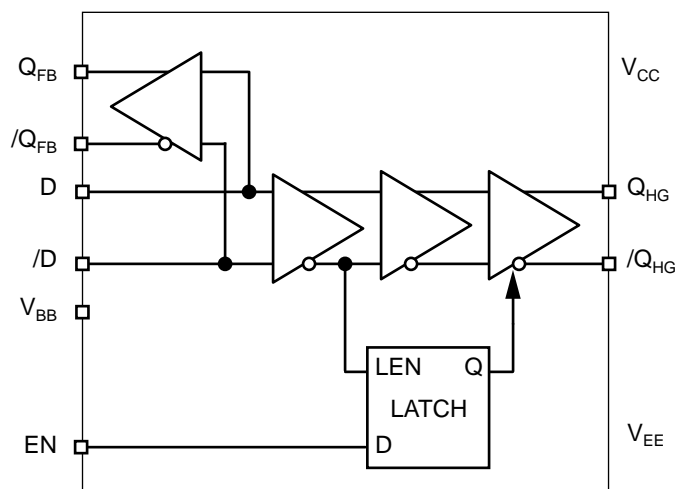

PACKAGE/ORDERING INFORMATION

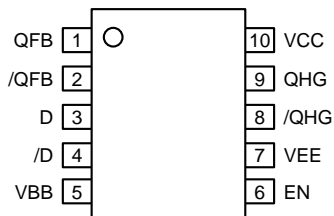

10-Pin MSOP (K10-1)

Ordering Information⁽¹⁾

Part Number	Package Type	Operating Range	Package Marking	Lead Finish
SY89207LMI	K10-1	Industrial	SY89207L	Sn-Pb
SY89207LMITR ⁽²⁾	K10-1	Industrial	SY89207L	Sn-Pb
SY89207LMG	K10-1	Industrial	SY89207L with Pb-Free bar-line indicator	Pb-Free NiPdAu
SY89207LMGTR ⁽²⁾	K10-1	Industrial	SY89207L with Pb-Free bar-line indicator	Pb-Free NiPdAu

Notes:

1. Contact factory for die availability. Dice are guaranteed at T_A = 25°C, DC electricals only.
2. Tape and Reel.

PIN DESCRIPTION

Pin Number	Pin Name	Pin Function
1, 2	QFB, /QFB	Differential clock outputs for feedback path: Nominal DC gain +10.
3, 4	D, /D	LVPECL, LVECL differential inputs: Internal 75kΩ pull-down resistor.
5	VBB	V _{CC} -1.32V reference voltage for single-ended inputs: It provides the switching reference for the input differential amplifier. When unused, it can be left open. For single-ended PECL applications connect V _{BB} to /D input. For differential AC-coupled inputs, terminate each input with 50Ω to V _{BB} as close to the input pins as possible. Always bypass the V _{BB} pin with a 0.01μF capacitor to V _{CC} .
6	EN	Enable: LVPECL/LVECL/CMOS compatible input control with internal 25kΩ pull-up resistor. It enables/disables the high-gain output (Q _{HG}). Default state is enabled, logic HIGH, if left floating. When EN pin is pulled to a logic LOW or GND, the Q _{HG} output pair will be latched, as described in the "Truth Table." EN is synchronous so that the outputs will only be enabled/disabled when they are in the LOW state. Input threshold is V _{BB} .
7	VEE	Negative power supply: For LVECL operation, connect to negative supply. For LVPECL operation, connect to GND.
8, 9	QHG, /QHG	Differential high-gain outputs: Nominal DC gain is greater than +200.
10	VCC	Positive power supply: For LVECL operation, connect to V _{CC} = 0V. For LVPECL operation, connect to 3.3V. Bypass with 0.1μF 0.01μF low ESR capacitors.

TRUTH TABLE

EN	QHG Out	/QHG Out
1	Data	/Data
0	Logic Low	Logic High

Absolute Maximum Ratings⁽¹⁾

Power Supply Voltage ($V_{CC} - V_{EE}$)	+6.0V
PECL Input Voltage (V_{IN})	0V to $V_{CC} + 0.5V$
Voltage Applied to Output at High State ($V_{EE} = 0V$)	-0.5V to +5.5V
Output Current (I_{OUT})	
Continuous	50mA
Surge	100mA
Lead Temperature (soldering, 10 sec.)	220°C
Storage Temperature (T_S)	-65°C to +150°C

Operating Ratings⁽²⁾

Supply Voltage (V_{IN})	+3.0V to +3.8V
Ambient Temperature (T_A)	-40°C to +85°C
Junction Temperature (T_J)	160°C
Package Thermal Resistance	
MSOP (θ_{JA})	
Still Air	113°C/W
MSOP (Ψ_{JB})	74°C/W

DC ELECTRICAL CHARACTERISTICS

$V_{CC} = +3.0V$ to $+3.8V$; $T_A = -40^\circ C$ to $+85^\circ C$; unless noted.

Symbol	Parameter	Condition	Min	Typ	Max	Units
V_{CC}	Power Supply Voltage (LVPECL) (LVECL)	$V_{EE} = GND$	3.0	3.3	3.8	V
		$V_{CC} = GND$	-3.8	-3.3	-3.0	V
I_{CC}	Power Supply Current	$V_{CC} = 3.8V$			46	mA
V_{BB}	Reference Voltage		$V_{CC} - 1.26$	$V_{CC} - 1.32$	$V_{CC} - 1.38$	V
I_{IH}	Input HIGH Current D, /D EN	$V_{IN} = V_{IH} (max)$			150	μA
		$V_{IN} = V_{CC}$			100	μA
I_{IL}	Input LOW Current D, /D EN	$V_{IN} = V_{IL} (min)$	0.5			μA
		$V_{IN} = GND$	-300			μA
C_{IN}	Input Capacitance			0.75		pF
EN	Enable	LVECL/LVPECL/CMOS compatible	V_{EE}		V_{CC}	V

LVPECL/LVECL DC ELECTRICAL CHARACTERISTICS

$V_{CC} = +3.0V$ to $+3.8V$ and $V_{EE} = 0V$, $V_{CC} = 0V$ and $V_{EE} = -3.0V$ to $-3.8V$; $T_A = -40^\circ C$ to $+85^\circ C$; unless otherwise noted.

Symbol	Parameter	Condition	Min	Typ	Max	Units
V_{OH}	Output High Voltage	50Ω to $V_{CC} - 2V$	2.215	2.305	2.42	V
V_{OL}	Output Low Voltage	50Ω to $V_{CC} - 2V$	1.470	1.595	1.745	V
V_{IH}	Input HIGH Voltage		2.135	—	2.420	V
V_{IL}	Input LOW Voltage		1.490	—	1.825	V
V_{IHCMR}	Input High Voltage Common Mode Range	Note 3	2.0	—	$V_{CC} - 0.8$	V

Notes:

1. Permanent device damage may occur if the ratings in the "Absolute Maximum Ratings" section are exceeded. This is a stress rating only and functional operation is not implied at conditions other than those detailed in the operational sections of this data sheet. Exposure to absolute maximum rating conditions for extended periods may affect device reliability.
2. The data sheet limits are not guaranteed if the device is operated beyond the operating ratings.
3. V_{IHCMR} is referenced to the most positive side of the differential input signal.

AC ELECTRICAL CHARACTERISTICS

$V_{CC} = +3.0V$ to $+3.8V$ and $V_{EE} = GND$ or $V_{EE} = -3.0V$ to $-3.8V$ and $V_{CC} = GND$; $T_A = -40^{\circ}C$ to $+85^{\circ}C$; unless noted.

Symbol	Parameter	Condition	Min	Typ	Max	Units
f_{MAX}	Maximum Frequency		800			MHz
t_{pd}	Propagation Delay (Diff.) to Q_{FB} , $/Q_{FB}$ (Single)				200 230	ps ps
	to Q_{HG} , $/Q_{HG}$ (Diff.) (Single)				730 780	ps ps
t_S	Set-Up Time	Enable Pin ⁽⁴⁾	650			ps
t_H	Hold Time	Enable Pin ⁽⁴⁾	650			ps
t_{JITTER}	Cycle-to-Cycle Jitter	RMS		0.2		ps
t_{SKEW}	Duty Cycle Skew	Note 5		5	20	ps
V_{PP}	Minimum Input Swing	Note 6	150			mV
t_r t_f	Output Rise/Fall Times (20% to 80%)	At full output swing			250	ps

Notes:

4. See "Timing Waveform" section.
5. Duty cycle skew is the difference between rise and fall time propagation delay through the device.
6. The device has a DC gain of 10 for Q, /Q outputs, and DC gain of 200 or higher for Q_{HG} , $/Q_{HG}$. See "Timing Waveform" minimum input swing.

TIMING WAVEFORMS

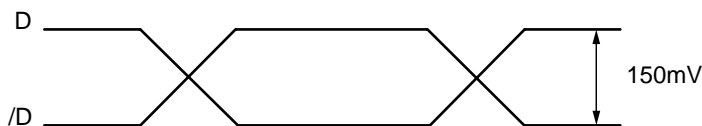

Figure 1. Minimum Input Swing

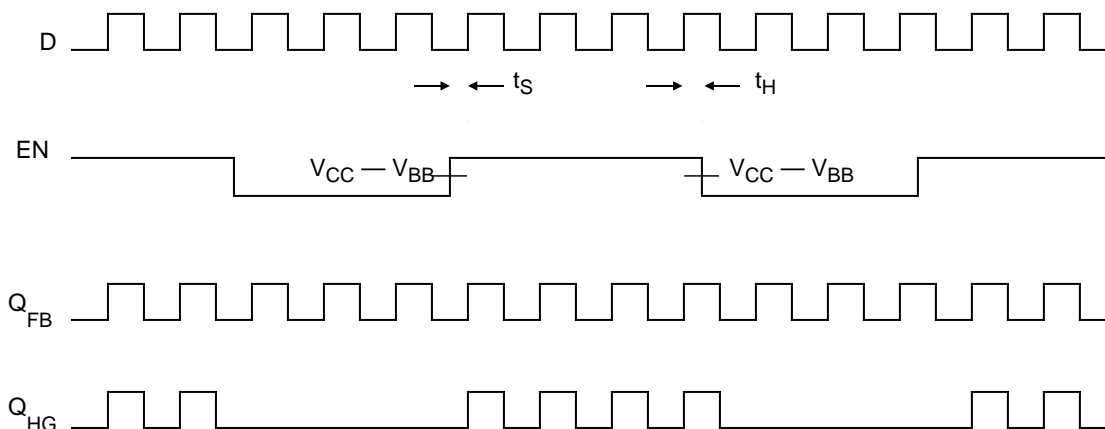

Figure 2. Set-Up and Hold Timing

TERMINATION RECOMMENDATIONS

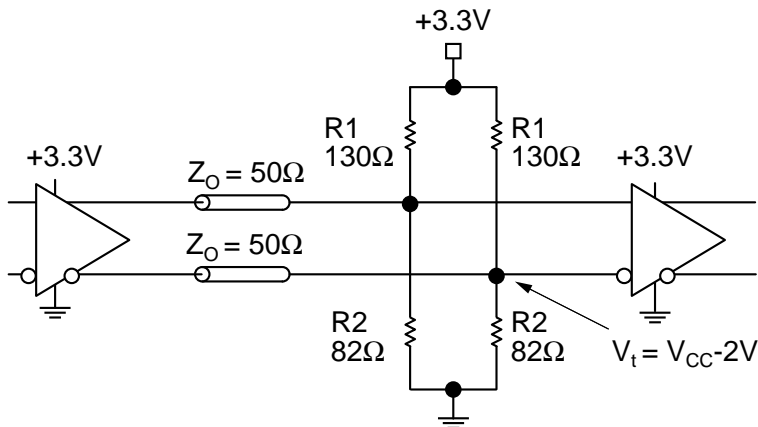

Figure 3. Parallel Termination–Thevenin Equivalent

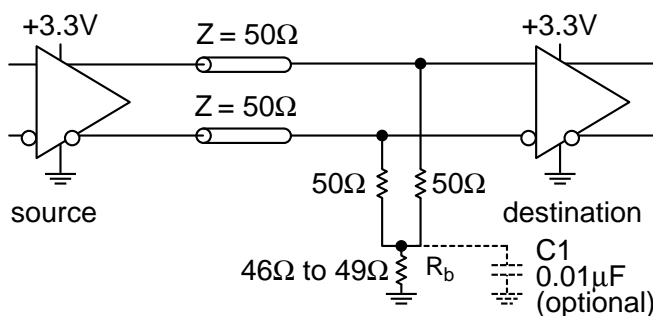
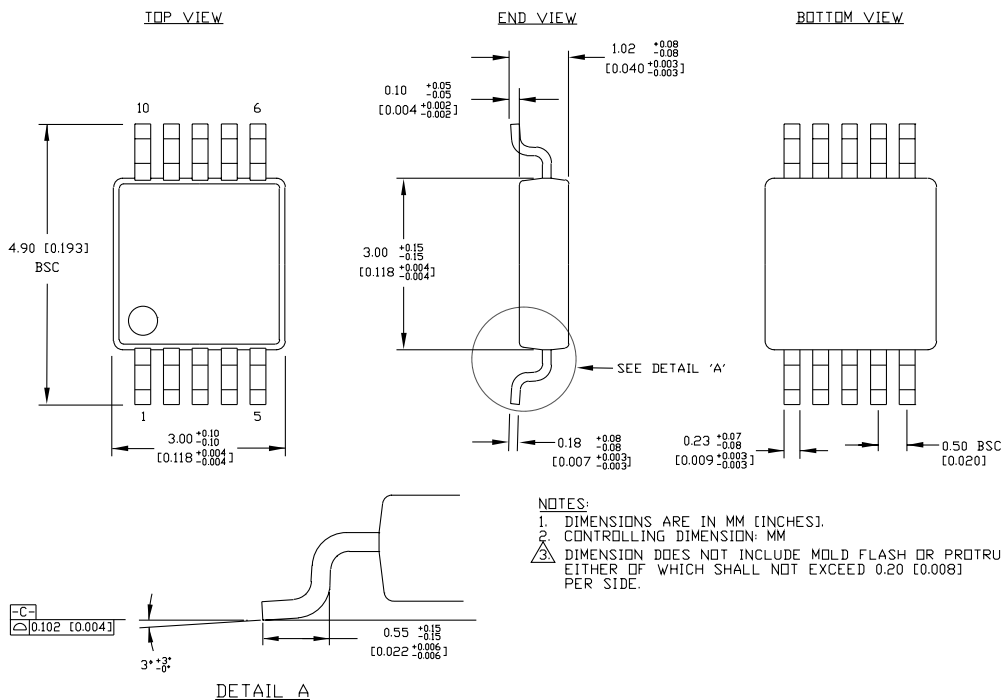

Figure 4. Three-Resistor ‘Y-Termination’

RELATED PRODUCT AND SUPPORT DOCUMENTATION

Part Number	Function	Data Sheet Link
SY100EL16VO	3.3V/5V 800MHz Precision PECL Amplifier with Low-Gain Feedback	www.micrel.com/product-info/products/sy100el16vo.shtml
SY89250V	3.3V/5V Enhanced Differential Receiver	www.micrel.com/product-info/products/sy89250v.shtml

10 LEAD MSOP (K10-1)



Rev. 00

MICREL, INC. 2180 FORTUNE DRIVE SAN JOSE, CA 95131 USA

TEL + 1 (408) 944-0800 FAX + 1 (408) 474-1000 WEB <http://www.micrel.com>

The information furnished by Micrel in this data sheet is believed to be accurate and reliable. However, no responsibility is assumed by Micrel for its use. Micrel reserves the right to change circuitry and specifications at any time without notification to the customer.

Micrel Products are not designed or authorized for use as components in life support appliances, devices or systems where malfunction of a product can reasonably be expected to result in personal injury. Life support devices or systems are devices or systems that (a) are intended for surgical implant into the body or (b) support or sustain life, and whose failure to perform can be reasonably expected to result in a significant injury to the user. A Purchaser's use or sale of Micrel Products for use in life support appliances, devices or systems is at Purchaser's own risk and Purchaser agrees to fully indemnify Micrel for any damages resulting from such use or sale.

© 2005 Micrel, Incorporated.