

FEATURES

- Up to 1.25Gbps operation
- 75mA peak drive current
- Separate modulation control
- Separate output enable for laser safety
- Differential inputs for data
- 75KΩ input pulldown resistor
- Single power supply
- Available in 16-pin SOIC package

DESCRIPTION

The SY100EL1003 is a high speed current source for driving a semiconductor laser diode in optical transmission applications. The output current modulation is DC – voltage controlled. The modulation current is disabled when output enable is HIGH.

The device incorporates complementary open collector outputs with a capability of driving peak current of 75mA. The laser driver current is adjustable by selection of RSET. The resistor REXT must be placed between $\overline{\text{OUT}}$ and VCC to dissipate the worst case power. RSER is recommended to fix laser diode matching issues.

The SY100EL1003 utilizes the high performance bipolar ASSET technology.

BLOCK DIAGRAM

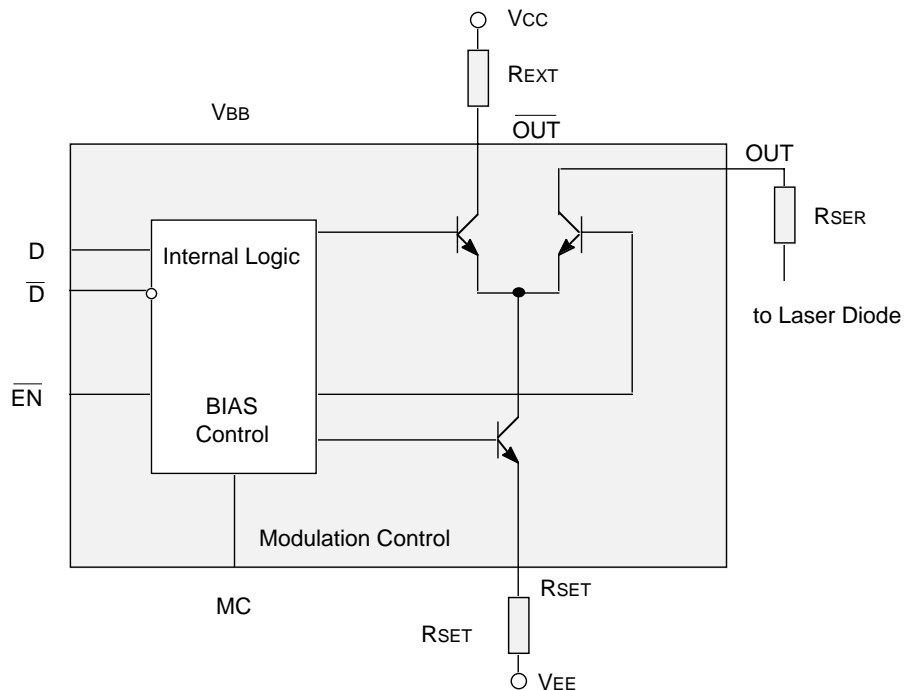

PACKAGE/ORDERING INFORMATION

Ordering Information⁽¹⁾

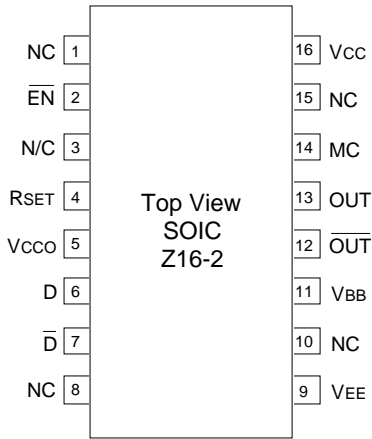

16-Pin Narrow SOIC (Z16-2)

Part Number	Package Type	Operating Range	Package Marking	Lead Finish
SY100EL1003ZC	Z16-2	Commercial	SY100EL1003ZC	Sn-Pb
SY100EL1003ZCTR ⁽²⁾	Z16-2	Commercial	SY100EL1003ZC	Sn-Pb
SY100EL1003ZI	Z16-2	Industrial	SY100EL1003ZI	Sn-Pb
SY100EL1003ZITR ⁽²⁾	Z16-2	Industrial	SY100EL1003ZI	Sn-Pb
SY100EL1003ZG ⁽³⁾	Z16-2	Industrial	SY100EL1003ZG with Pb-Free bar-line indicator	Pb-Free NiPdAu
SY100EL1003ZGTR ^(2, 3)	Z16-2	Industrial	SY100EL1003ZG with Pb-Free bar-line indicator	Pb-Free NiPdAu

Notes:

1. Contact factory for die availability. Dice are guaranteed at T_A = 25°C, DC Electricals only.
2. Tape and Reel.
3. Pb-Free package is recommended for new designs.

PIN NAMES

Pin	Function
Vcc, Vcco	Separate positive power supply pins help to isolate sensitive circuitry from noise generating function. +5V for PECL operation or ground for ECL operation.
VEE	Most negative power supply input. Ground for PECL operation or -5V for ECL operation.
VBB	This pin provides a reference voltage for use in single ended applications or when the input signal is AC coupled into the device.
D, \bar{D}	These differential ECL/PECL 100K compatible inputs receive NRZ data.
\bar{EN}	This ECL/PECL 100K compatible input enables Laser Driver - modulation current transitions to zero when asserted HIGH.
OUT, \bar{OUT}	Open collector outputs from the modulation buffer drive these differential current outputs.
MC	An external voltage sets the main value of modulation current I _o .
RSET	An external resistor sets the source current for modulation I _{mod} .
NC	These pins are not connected.

TRUTH TABLE⁽¹⁾

D	\bar{D}	\bar{EN}	OUT	\bar{OUT}
L	H	L	H	L
H	L	L	L	H
X	X	H	H	L

NOTE:

1. L = LOW, H = HIGH, X = don't care

ABSOLUTE MAXIMUM RATINGS⁽¹⁾

Symbol	Rating	Value	Unit
VEE	Power Supply Voltage (V _{cc} = 0V)	0 to -7.0	V
V _{IN}	Input Voltage (V _{cc} = 0V)	0 to -6.0	V
I _{OUT}	Output Current	75	mA
T _{LEAD}	Lead Temperature (soldering, 20sec.)	+260°	°C
T _A	Operating Temperature Range	-40 to +85°	°C
P _{tot}	Power Dissipation	500	mW

Note:

1. Permanent device damage may occur if absolute maximum ratings are exceeded. This is a stress rating only and functional operation is not implied at conditions other than those detailed in the operational sections of this data sheet. Exposure to absolute maximum rating conditions for extended periods may affect device reliability.

OPERATIONING CONDITIONS⁽¹⁾

Symbol	Rating	Value	Unit
VEE	Power Supply Voltage	-4.75 to -5.25	V
RSET	Resistor to Adjust Current	10 to 100	Ω
REXT	Resistor to Dissipate Power	10 to 50	Ω
RSER	Laser Diode Serial Resistor	0 to 50	Ω

Note:

1. The voltage drop across REXT and RSER should not be greater than 2V.

DC ELECTRICAL CHARACTERISTICS⁽¹⁾

VCC = VCCO = 0V; VEE = -5.0V ± 5%

Symbol	Parameter	TA = -40°C			TA = 0°C			TA = +25°C			TA = +85°C			Unit
		Min.	Typ.	Max.	Min.	Typ.	Max.	Min.	Typ.	Max.	Min.	Typ.	Max.	
V _{IH}	Input HIGH Voltage (D, \overline{EN})	-1165	—	-880	-1165	—	-880	-1165	—	-880	-1165	—	-880	mV
V _{IL}	Input LOW Voltage (D, \overline{EN})	-1810	—	-1475	-1810	—	-1475	-1810	—	-1475	-1810	—	-1475	mV
V _{Imod}	Input Voltage (Modulation Control)	V _{EE}	—	V _{CC}	V _{EE}	—	V _{CC}	V _{EE}	—	V _{CC}	V _{EE}	—	V _{CC}	V
V _{BB}	Output Reference Voltage	-1380	—	-1260	-1380	—	-1260	-1380	—	-1260	-1380	—	-1260	mV
I _{IH}	Input HIGH Current (D, \overline{EN})	—	—	150	—	—	150	—	—	150	—	—	150	μA
I _{Imod}	Input Current (Modulation Control)	—	—	150	—	—	150	—	—	150	—	—	150	μA
I _{IL}	Input LOW Current ⁽²⁾ (D, \overline{EN})	0.5	—	—	0.5	—	—	0.5	—	—	0.5	—	—	μA
I _{CC}	Supply Current ⁽³⁾	8	14	25	8	14	25	8	14	25	8	14	25	mA
I _{OH}	Output HIGH Current ⁽⁴⁾ (\overline{EN} LOW) ⁽⁵⁾	60	64 —	68 —	60 5	64 —	68 —	60 5	64 —	68 —	60 5	64 —	68 —	mA 5
I _{OL}	Output LOW Current (\overline{EN} HIGH)	—	—	500	—	—	500	—	—	500	—	—	500	μA
I _{OR}	Output Current Ringing ⁽⁶⁾	—	—	10	—	—	10	—	—	10	—	—	10	%
I _{omod}	Laser Diode Modulation Current Range	5	—	60	5	—	60	5	—	60	5	—	60	mA

Notes:

1. R_{SET} = 10Ω ± 1%
2. V_I = V_{IL}(Min.)
3. V_{Imod} = V_{CC}
4. V_{Imod} = -3.5V
5. V_{Lmod} = -0.8V
6. I_{OH} = 5 to 60mA

AC ELECTRICAL CHARACTERISTICS⁽¹⁾V_{Imod} = -1.5V; VCC = VCCO = 0V; VEE = -5V ± 5%

Symbol	Parameter	TA = -40°C			TA = 0°C			TA = +25°C			TA = +85°C			Unit
		Min.	Typ.	Max.	Min.	Typ.	Max.	Min.	Typ.	Max.	Min.	Typ.	Max.	
t _{pd} D	Propagation Delay D - OUT	—	—	1000	—	—	1000	—	—	1000	—	—	1000	ps
t _{pd} \overline{EN}	Propagation Delay \overline{EN} - OUT	—	—	1000	—	—	1000	—	—	1000	—	—	1000	ps
t _r t _f	Rise/Fall Time (20% to 80%)	—	—	400	—	—	400	—	—	400	—	—	400	ps

Note:

1. R_{SET} = 10Ω ± 1%, R_{EXT} = R_{SER} = 50Ω ± 1%

PERFORMANCE CURVES

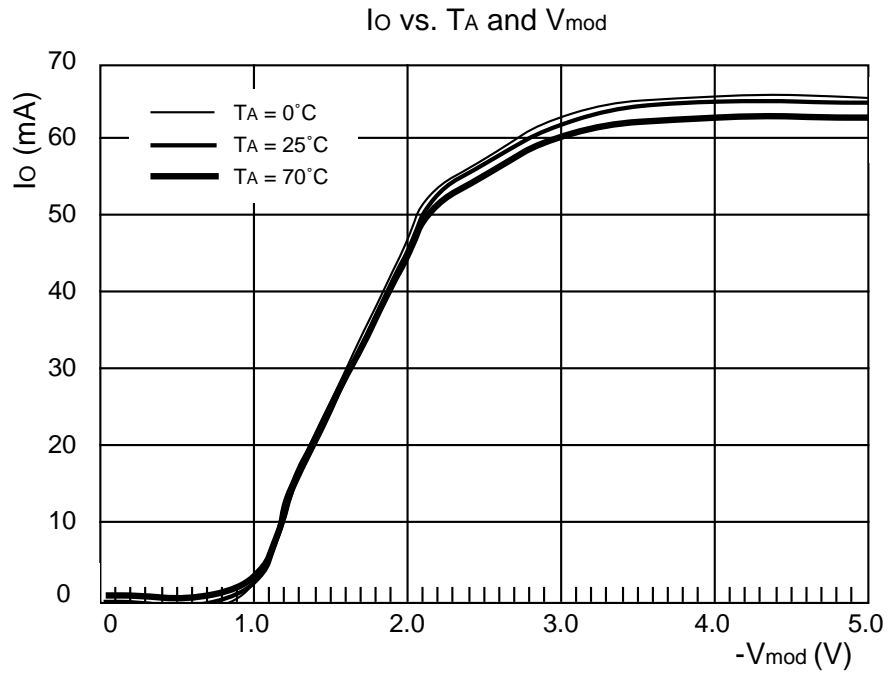

APPLICATION EXAMPLE

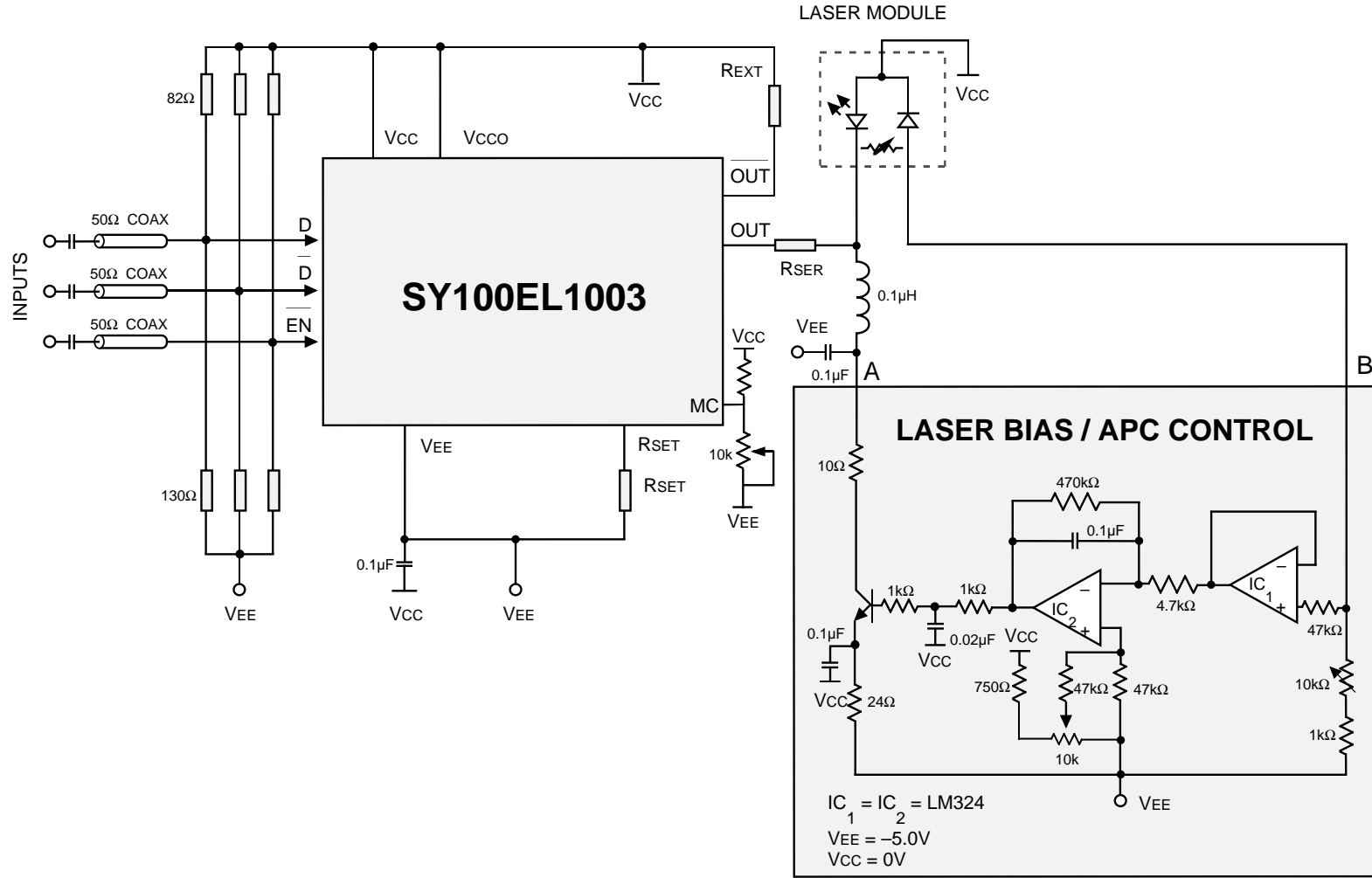

NOTES:

1. Split 100K ECL terminations are 82Ω and 130Ω to Vcc and VEE respectively.
2. Recommended power supply bypass capacitors are 0.1μF with optional 10μF Tantalum in parallel.
3. It is required to use high frequency design techniques for board layout. A double sided or multilayer board is recommended in conjunction with a low impedance ground plane and properly terminated transmission lines for all signal paths.
4. V_{BB} voltage pin may be used as reference for single ended input applications.

16-PIN SOIC .150" WIDE (Z16-2)

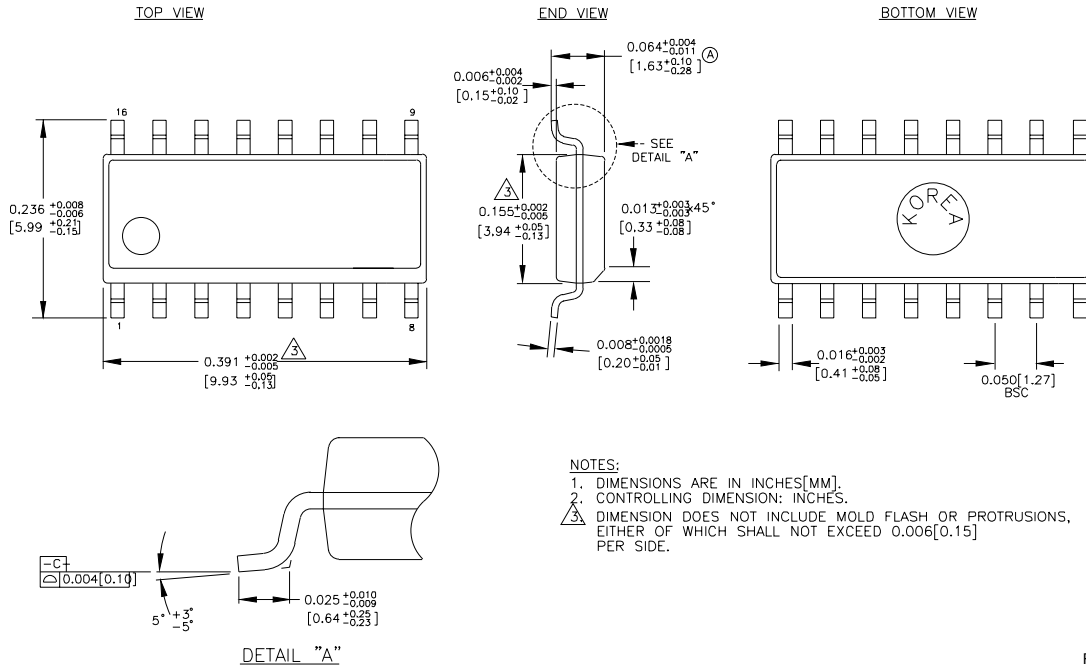

Rev. 02

MICREL, INC. 2180 FORTUNE DRIVE SAN JOSE, CA 95131 USA

TEL + 1 (408) 944-0800 FAX + 1 (408) 474-1000 WEB <http://www.micrel.com>

The information furnished by Micrel in this datasheet is believed to be accurate and reliable. However, no responsibility is assumed by Micrel for its use. Micrel reserves the right to change circuitry and specifications at any time without notification to the customer.

Micrel Products are not designed or authorized for use as components in life support appliances, devices or systems where malfunction of a product can reasonably be expected to result in personal injury. Life support devices or systems are devices or systems that (a) are intended for surgical implant into the body or (b) support or sustain life, and whose failure to perform can be reasonably expected to result in a significant injury to the user. A Purchaser's use or sale of Micrel Products for use in life support appliances, devices or systems is at Purchaser's own risk and Purchaser agrees to fully indemnify Micrel for any damages resulting from such use or sale.

© 2006 Micrel, Incorporated.