



SY88973/SY88982/MIC3001-Based SFP Module

TXRX_982_R1 Evaluation Board

General Description

This evaluation board is an implementation of the SFP module in a different form factor with on board faults indicators (LEDs) and a DB-25 connector for serial communication. The design uses Micrel's MIC3001 controller, SY88982 (pin compatible with SY88782 and SY88932) driver, and SY88973 limiting amplifier. A picture of the fully bonded board is shown below.

Data sheets and support documentation can be found on Micrel's web site at www.micrel.com.

Related Support Documentation

- MIC3001 Data Sheet
- SY89307 Data Sheet
- SY89973 Data Sheet
- MIC3000/1 Software User's Guide

Features

- Allows for easy and fast evaluation of Micrel's chipset for SFP module
- On board FAULTs indicators
- Easy access to the components for rework and different options implementation

IC Description

- SY88982: Low power small form factor (3mm x 3mm) laser driver up to 3.2Gbps data rate and 2.3V compliance voltage. SY88782 is a lower speed version up to 1.25Gbps.
- MIC3001: SFP module controller featuring digital diagnostic monitoring interface as per SFF-8472 with internal/external calibration and full laser control with bias and modulation current compensation for temperature variations using look up tables.
- SY88973: Multi-rate 155-3200Mbps low sensitivity limiting amplifier.

Evaluation Board

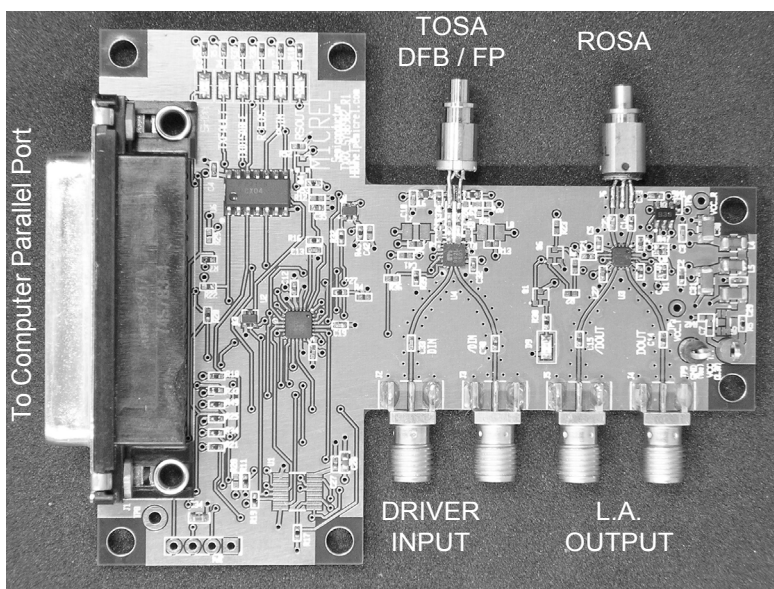

Evaluation Board Setting

Driver Laser Coupling

Table 1 summarizes the setting of the board for the two configurations, driver DC-coupled or AC-coupled to the laser.

Configuration	Remove	Install
Driver and Laser DC-Coupled	L2, L3, L7, L8, R14, R6, R13, C24, C36	Install a 0Ω at C24 and C38.
Driver and Laser AC-Coupled		L2, L3, L7, L8, R14, R6, R13, C24, C36

Table 1. Configuration Settings

Receiver Sensitivity and Hysteresis Setting

SY88973 Limiting Amplifier

The SY88973 limiting amplifier is the default post amplifier installed on the board. It has a receive signal LOS indicator. To improve the hysteresis on the receive signal LOS, install R2 and uninstall R3. The combination of R2 and R1 will determine the sensitivity of the transceiver and hysteresis on the receive signal LOS. Refer to the application note entitled "Notes on Sensitivity and hysteresis in Micrel's Post Amplifiers" available at

http://www.micrel.com/product-info/app_hints+notes.shtml.

SY88843 Limiting Amplifier

The SY88843 limiting amplifier has a signal detect (SD) indicator. To improve the hysteresis on the receive signal LOS, remove R2 and install R3, Q6, and R23. The combination of R3 and R1 will determine the sensitivity of the transceiver and hysteresis on the SD. Refer to the application note entitled "Notes on Sensitivity and hysteresis in Micrel's Post Amplifiers" available at

http://www.micrel.com/product-info/app_hints+notes.shtml.

TOSA and ROSA Installation

Check the pinout of the laser and receiver and install them accordingly to the diagrams shown on Figure 1.

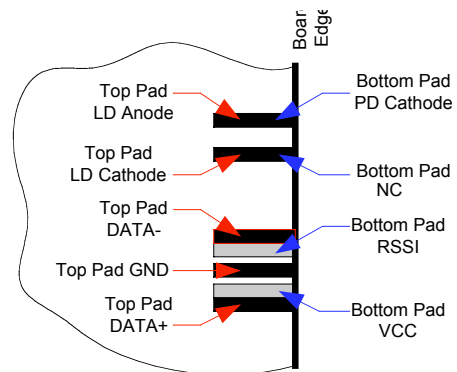

Figure 1. Mounting of Laser and Receive

Set-Up and Operation

Follow the step-by-step procedure to set-up the board safely and properly:

1. Connect the on board DB-25 connector to the parallel port of a computer.
2. Connect the differential input of the laser driver to DATA output of the pattern generator.
3. Use a multimode fiber jumper, with appropriate connectors to connect optical output of the VCSEL to a VOA (variable optical attenuator) preset to 0dB attenuation.
4. Connect the output of the VOA to the optical input of the DCA, power-meter, or optical to electrical converter.
5. Pre-adjust the power supply to 3.3V and turn it off. Connect TP3 to V_{CC} (3.3V) and TP5 to GND, then turn the power supply ON. The total current drawn from the power supply should be less than 300mA.
6. Launch the MIC3000/1 software. The **MIC3001 Optical Transceiver Management IC** panel opens with **Panels** and **Help** grayed out and only **Utilities** can be run.
7. Refer to MIC3000/1 Software User's Guide for the detailed settings.
8. On the main window select **Utilities** to open the utilities panel, then select **SCAN** to read the address of the MIC3001 and **GET** to read the manufacturer ID, Device ID, and Die Revision. If there is a failure in reading one of these parameters, you cannot proceed further. If all the parameters are read correctly, close the **Utilities window** to return to the main window where **Panels** and **Help** are no longer grayed out.
9. Select **Panels** to display the list of setting panels.
10. All the bits displayed on the panels can be read and/or modified on the panels or by accessing the registers directly by selecting **ALL REGISTERS**, enter the serial address, the register address, select **GET** to read the content or type a value and select **SET NEW** to write. In this procedure the bits are set on the panels.
11. Select **OEM CONFIG 0-2** to open the OEM configuration registers 0, 1, and 2 windows.
12. In **OEM Configuration Register 0** window, set **ENABLE/DISABLE** to **DISABLE**, **VMOD REFERENCE** to **GND**, and **temperature zone** to **INTERNAL**.
13. In **OEM Configuration Register 1** window:
 - a. Set **APC OP-AMP TYPE** to **COMMON EMITTER**.

Note: Set the selection bit to 0, 0 should correspond to **EMITTER FOLLOWER**, which should be displayed on the bottom and **COMMON EMITTER** on the top.

 - b. Select the voltage to report in **VINH:VINL**.
 - c. Set Feedback voltage source to 1.22V.
 - d. Set **FEEDBACK BIAS REF and RES TERMINATION** to **GND** and **VBIAS DRIVE** to **SOURCE (NPN)**. Set **INTERNAL FEEDBACK RESISTOR** to an arbitrary value (1.6K for example).
 - e. Set **FEEDBACK BIAS REF and RES TERMINATION** to **GND** and **VBIAS DRIVE** to **SOURCE (NPN)**.
 - f. Set **INTERNAL FEEDBACK RESISTOR** to arbitrary value (1.6K for example).
14. In **OEM Configuration Register 2**, the MIC3001 address and look-up table offset can be modified. The look-up table covers 128°C. The temperature range for offset = 0 is 0° to +127°C.) This range can be shifted down by 2x the value. The offset is set to. If offset = 15, the temperature range becomes -30° to +97°C.
15. In **OEM Configuration Register 0** window, set **ENABLE/DISABLE** to **ENABLE**.
16. On **Panels** list select **OEM CONFIG 3-4** and select **EXTERNAL CALIBRATION** (default setting), **LOS COMPARATOR ENABLE**, **SHDN**, **RXLUT INPUT TEMPERATURE**, and **RSOUT**. If needed, later set **ISTART** to a different value to speed up the APC loop during laser turn ON after a **FAULT** occurrence. Close the window to return to main window.
17. On **Panels** list, select **External Calibration**. Set all the **offsets** to 0 and **slopes** to 1. Set **RX_PWR(1)** to 1. These parameters might need to be changed later to correct the measured values (calibration). Return to the main window.

18. On **Panels** list, select **Temperature Compensation**. Load look-up tables for APC, Modulation, Bias current Fault, and End-of-Life from appropriate files. If no loading is done, the default value 0 is used for all the LUT. Return to the main window.
19. On **Panels** list, select **OEM settings**. Enter the desired DAC values between 0 and 255 for the displayed parameters then select **SET NEW**. Select **GET CURRENT** to make sure that the set values are written into the registers. Checking them can mask the faults. Return to the main window.
20. On **Panels** list, select **User**. Check **APC0** in the **USER CONTROL REGISTER** (default setting). All the other parameters can be checked later to verify their functionality. Return to the main window.
21. On **Panels** list, select **Result**. The values of the five monitored parameters as per SFF-8472 are now displayed. Type the **alarm** and **warning** thresholds and select **SET NEW LIMITS**. Select **GET CURRENT LIMITS** to check that the set values are written into the registers. Return to main window.
22. Set modulation current and bias current to get the desired output power and extinction ratio out of the laser. Use **OEM Settings** panel or **TX Setup** panel to do that:
 - a. In **OEM settings** window, set the bias by entering a value from 10 to 255 in **APC SET POINT 0** box and modulation by entering a value from 10 to 255 in MOD DAC setting box followed by SET new.
 - b. In **TX calibration** window, set the bias by entering a value from 10 to 255 in **APCO (DEC)** box and modulation by entering a value from 10 to 255 in MOD DAC setting box followed by SET new.
23. At this step, there is no received power since no signal is applied at the input of the receiver.
24. Adjust the VOA to bring the optical power to the desired level at the input of the receiver. Then connect the output of the VOA to the input of the receiver using appropriate fiber jumper.
25. If the installed receiver has RSSI signal, a value (needs calibration) of the received power should be displayed now.
26. On **Panels** list, select **TX Setup** to calibrate the TX power. Measure the optical power at the output of the VCSEL and enter the value (in mW) in the **MEASURED TX POWER** box, then select **CALIBRATE**. The monitored value is adjusted to display the measured value by automatically changing the slope set in the **EXTERNAL CALIBRATION** window. Reconnect the VOA to the VCSEL and return to the main window.
27. On **Panels** select **RX Calibration**. Measure the input power to receiver at the output of the VOA and enter the measured value (in mW) in the **MEASURED RX POWER** box then select **CALIBRATE**. The monitored value is adjusted to display the measured value by automatically changing the slope set in the **EXTERNAL CALIBRATION** window. Reconnect the VOA to the receiver and return to the main window.
28. At this stage, the masked faults should be unmasked and if there is a fault indication try to find the cause for it and fix it to get the transceiver running fault free and try to measure the performance of the laser driver and post amplifier.

After setting the new value for bias or modulation current, toggle TXDISABLE/TXENABLE on the main window.

Laser Response Tuning

Overshoot/Undershoot

The damping resistors R8 and R24 installed in series with laser are 20Ω . This value might be tuned to a higher value to minimize or suppress any overshoot or undershoot on the optical signal out of the laser, but keep in mind that higher value damping resistors will lead to higher rise/fall time.

Laser's Package Inductance Compensation

A compensation network comprised of C9/R26 or C9/R31 can be used to compensate for the laser package inductance. R26 and R31 share the same pad on the board, so only one at a time can be installed. The values shown on the schematic are used for the symbol only. C9 should be a few pF and R26/R31 around 50Ω .

Performance

Figure 2 shows an optical eye diagram obtained with a Fabry Perrot laser driven differentially.

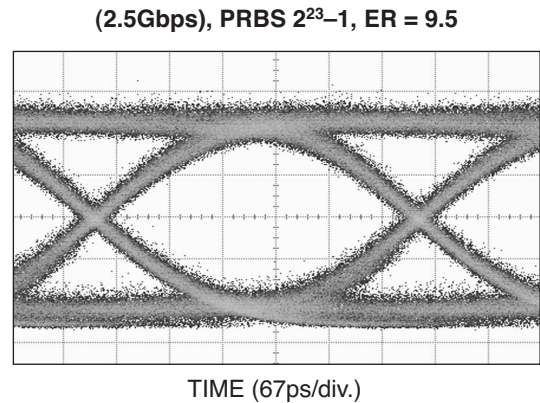

Figure 2. Optical Eye Diagram

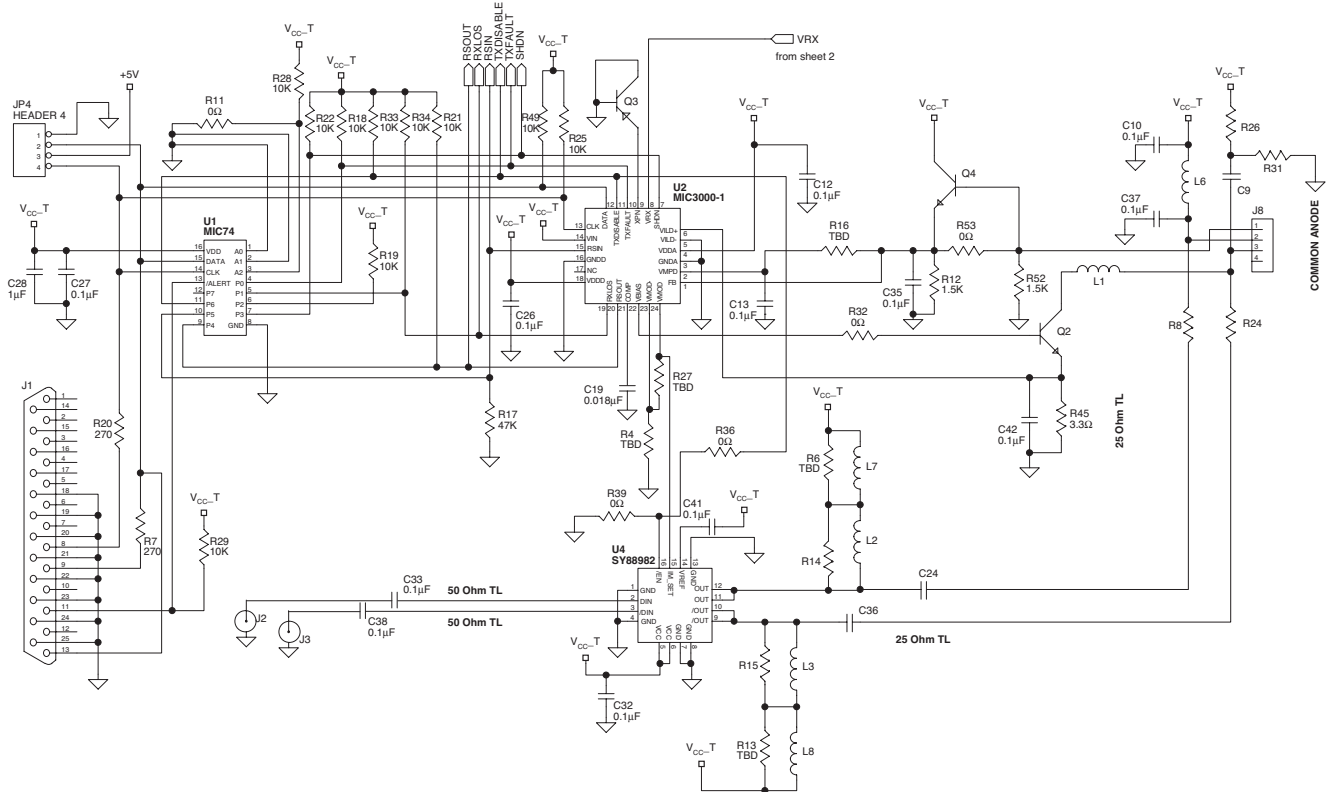

Figure 2. Transmitter

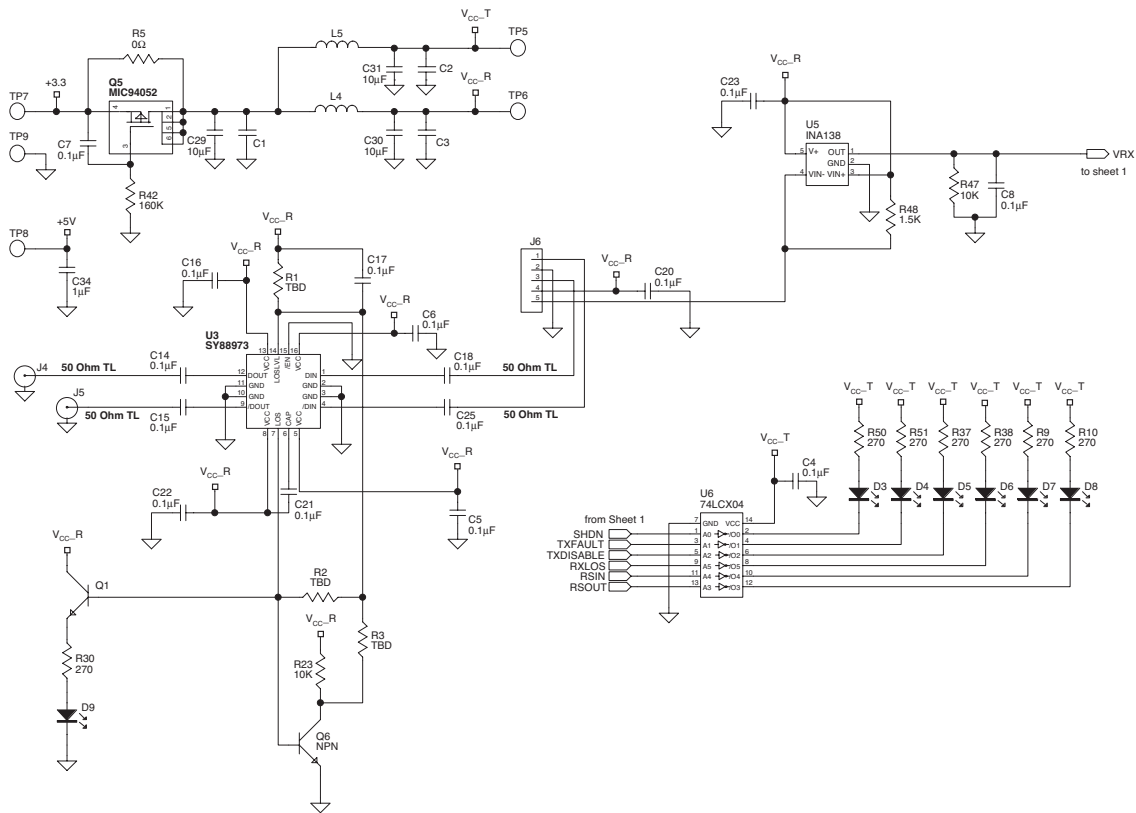
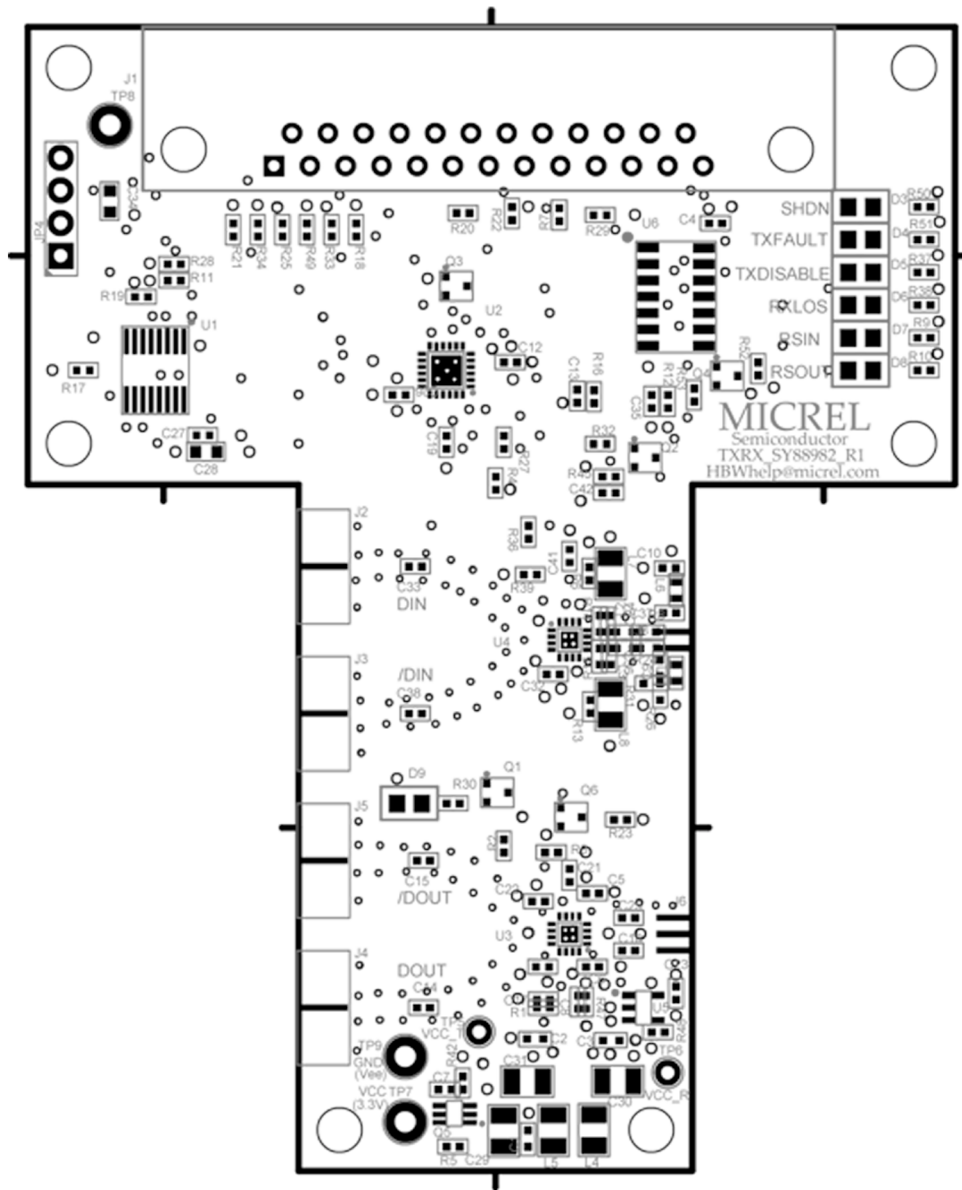

Figure 3. Receiver

PCB Layout/Assembly



Bill of Materials

Driver AC-Coupled to the Laser

Item	Part Number	Manufacturer	Description	Qty.
C1–C6, C8, C10, C12–C18, C20–C27, C32, C33, C35–C38, C41, C42		Vishay ⁽¹⁾	0.1 μ F, 25V, 10% Ceramic Capacitor, Size 0402	31
C19		Vishay ⁽¹⁾	0.01 μ F Ceramic Capacitor, Size 0402	1
C28, C34		Vishay ⁽¹⁾	1 μ F Ceramic Capacitor, Size 0603	2
C29-C31	ECSH0GY106R	Vishay ⁽¹⁾	10 μ F, Y, Tantalum Solid Electrolytic Capacitor, Size 1206	1
D3-D9	67-1636-1-ND	Digi-Key ⁽²⁾	Red, LED	7
J1	745783	AMP ⁽³⁾	Receptacle DB-25 R/A Connector, 25 Position	1
J2-J5	142-0711-821	Johnson Components ⁽⁴⁾	SMA End Launch Receptacle Connector	4
J6	D12M-9060-A	Luxnet ⁽⁵⁾	ROSA	1
J8	FOL137-xx-Oxx-x4	Fitel ⁽⁶⁾	FP/DFB Laser, Common Anode	1
L1–L3, L6	BLM18HG102SN	Murata ⁽⁷⁾	Inductor	4
L4, L5, L7, L8	IMC 0805 RK 122 J 01	Vishay ⁽¹⁾	1.2 μ H Ferrite Bead Inductor, Size 1206	2
Q2	MMBT3904	Fairchild Semiconductor ⁽⁸⁾	General Purpose NPN Transistor (SOT-23)	2
Q3	MMBT3906	Fairchild Semiconductor ⁽⁸⁾	General Purpose PNP Transistor (SOT-23)	2
R1, R18, R19, R21, R22, R25, R28, R29, R33, R34, R47, R49	CRCW04021002F	Vishay ⁽¹⁾	10k Ω , 5% Resistor, Size 0402	12
R5, R11, R16, R27, R32, R39, R53	CRCW04021002F	Vishay ⁽¹⁾	0 Ω , 1% Resistor, Size 0402	7
R6, R13	CRCW040275R0F	Vishay ⁽¹⁾	75.0 Ω , 1% Resistor, Size 0402	2
R7, R9, R10, R20, R30, R37, R38, R50, R51	CRCW04022740F	Vishay ⁽¹⁾	274 Ω , 5% Resistor, Size 0402	9
R8, R24	CRCW0402230R1F	Vishay ⁽¹⁾	30.1 Ω , 1% Resistor, Size 0402	2
R14, R15	CRCW040233R2F	Vishay ⁽¹⁾	33.2 Ω , 1% Resistor, Size 0402	2
R17	CRCW04024752F	Vishay ⁽¹⁾	47k Ω , 1% Resistor, Size 0402	2
R45	CRCW04023R32F	Vishay ⁽¹⁾	3.32 Ω , 1% Resistor, Size 0402	1
R48	CRCW04021501F	Vishay ⁽¹⁾	1.5k Ω , 5% Resistor, Size 0402	1
TP3	5010	Keystone ⁽⁹⁾	Red, Color Coded PCB Test Point	1
TP5	5010	Keystone ⁽⁹⁾	Black, Color Coded PCB Test Point	1
U1	MIC74	Micrel ⁽¹⁰⁾	2-Wire Serial I/O Expander	1
U2	MIC3001	Micrel ⁽¹⁰⁾	Optical Transceiver Management IC	1
U3	SY88973	Micrel ⁽¹⁰⁾	3.2Gbps Limiting Post Amplifier	1
U4	SY88982	Micrel ⁽¹⁰⁾	Laser Driver	1
U5	INA138	TI (Burr-Brown) ⁽¹¹⁾	High Side Measurement Current Shunt Monitor	1
U6	74LCX04	Fairchild ⁽⁸⁾	Low Voltage Hex Inverter with 5V Tolerant Inputs	1
	TXRX_982_R1	Micrel ⁽¹⁰⁾	Bare PCB	1

Notes:

1. Vishay: www.vishay.com
2. Digi-Key: www.digikey.com
3. AMP: www.amp.com
4. Johnson Components: www.johnsoncomponents.com
5. Luxnet: www.luxnetcorp.com
6. Honeywell: www.furukawa.com
7. Murata: www.murata.com
8. Fairchild Semiconductor: www.fairchildsemi.com
9. Keystone: www.keystone.com
10. Micrel, Inc.: www.micrel.com
11. TI: www.ti.com

Micrel Cross Reference

To find an equivalent Micrel part, go to Micrel's website at: <http://www.micrel.com> and follow the steps below:

1. Click on Dynamic Cross Reference.
2. Enter competitor's part number in the Dynamic Cross Reference field.
3. To download a PDF version of this information, click on the Cross Reference PDF tab.

Application Hints and Notes

For application notes on high speed termination on PECL and LVPECL products, clock synthesizer products, SONET jitter measurement, and other High Bandwidth product go to Micrel Semiconductors' website at <http://www.micrel.com/>. Once in Micrel's website, follow the steps below:

1. Click on "Product Info".
2. In the Applications Information Box, choose "Application Hints and Application Notes."

HBW Support

Hotline: 408-955-1690

Email Support: HBWHelp@micrel.com

MICREL, INC. 1849 FORTUNE DRIVE SAN JOSE, CA 95131 USA
TEL +1 (408) 944-0800 FAX +1 (408) 474-1000 WEB <http://www.micrel.com>

The information furnished by Micrel in this data sheet is believed to be accurate and reliable. However, no responsibility is assumed by Micrel for its use. Micrel reserves the right to change circuitry and specifications at any time without notification to the customer.

Micrel Products are not designed or authorized for use as components in life support appliances, devices or systems where malfunction of a product can reasonably be expected to result in personal injury. Life support devices or systems are devices or systems that (a) are intended for surgical implant into the body or (b) support or sustain life, and whose failure to perform can be reasonably expected to result in a significant injury to the user. A Purchaser's use or sale of Micrel Products for use in life support appliances, devices or systems is a Purchaser's own risk and Purchaser agrees to fully indemnify Micrel for any damages resulting from such use or sale.

© 2004 Micrel. Incorporated.