

DATA SHEET
SE2435L: 860 – 930 MHz High Power RF Front End Module

Applications

- Smart Meters
- In-home appliances
- Smart thermostats

Features

- Integrated PA with 30 dBm output power
- Integrated LNA with programmable bypass
- Integrated antenna switching with Tx and Rx diversity function
- Low FEM noise figure of 2 dB typical
- Single ended 50 Ω Tx/Rx RF interface
- Fast turn-ON / turn-OFF time <1 μsec
- 2.0 V – 4.8 V supply operation
- Sleep mode current <1 μA
- 4 x 4 x 0.9 mm 24 pin QFN, NiPdAu plated
- Pb-free, RoHS compliant and Halogen free

Product Description

The SE2435L is a high performance, highly integrated RF Front End Module designed for high power ISM band applications operating in the 860 – 930 MHz frequency band.

The SE2435L is designed for ease of use and maximum flexibility, with fully matched 50 Ω input and output, and digital controls compatible with 1.6 – 3.6 V CMOS levels.

The RF blocks operate over a wide supply voltage range from 2.0 to 4.8 V allowing the SE2435L to be used in battery powered applications over a wide spectrum of the battery discharge curve.

Ordering Information

Part No.	Package	Remark
SE2435L-S	24 pin QFN	Samples
SE2435L-R	24 pin QFN	Tape & Reel
SE2435L-EK1	N/A	Evaluation kit

Functional Block Diagram

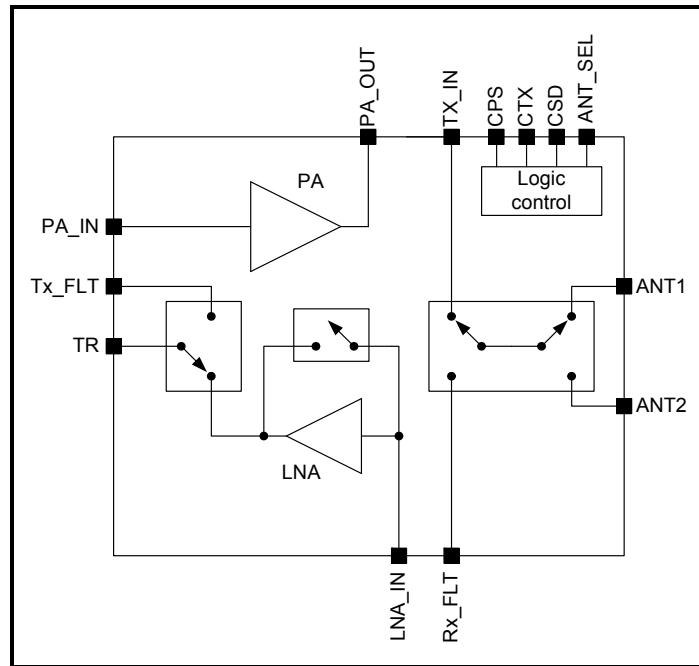

Figure 1: Functional Block Diagram

DATA SHEET
SE2435L: 860 – 930 MHz High Power RF Front End Module

Pin Out Diagram

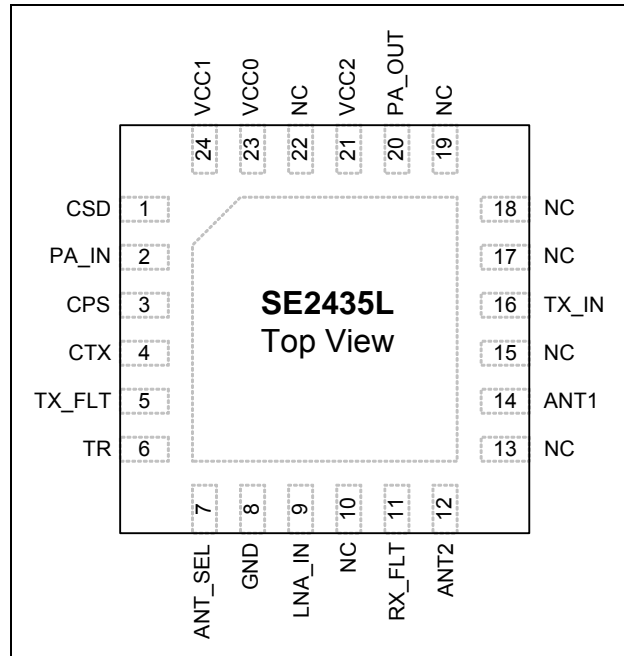

Figure 2: SE2435L Pinout

Pin Out Description

Pin No.	Name	Description
1	CSD	Shutdown control input
2	PA_IN	PA input (from Tx filter)
3	CPS	Rx path select control input
4	CTX	Transmit enable control input
5	TX_FLT	Transmit signal (to Tx filter)
6	TR	Bi-directional RF signal to/from transceiver
7	ANT_SEL	Antenna select control input
8	GND	Ground
9	LNA_IN	LNA input (from Rx filter)
10	NC	Not connected internally to the device
11	RX_FLT	Rx signal from antennas (to Rx filter)
12	ANT2	Antenna port 2
13	NC	Not connected internally to the device
14	ANT1	Antenna port 1

DATA SHEET
SE2435L: 860 – 930 MHz High Power RF Front End Module

Pin No.	Name	Description
15	NC	Not connected internally to the device
16	TX_IN	Tx signal to antennas (from OMN)
17	NC	Not connected internally to the device
18	NC	Not connected internally to the device
19	DNC	Do not connect
20	PA_OUT	PA output (to OMN)
21	VCC2	Positive power supply
22	NC	Not connected internally to the device
23	VCC0	Positive power supply
24	VCC1	Positive power supply
Paddle	GND	Exposed die paddle; electrical and thermal ground; Connect to PCB ground

Absolute Maximum Ratings

These are stress ratings only. Exposure to stresses beyond these maximum ratings may cause permanent damage to, or affect the reliability of the device. Avoid operating the device outside the recommended operating conditions defined below.

Symbol	Definition	Note	Min.	Max.	Unit
VCC	Supply Voltage – No RF	1	-0.3	5.5	V
	Control pin voltages		-0.3	3.6	V
T _{OP}	Operating temperature		-40	85	°C
T _{STORAGE}	Storage temperature		-40	125	°C
	ESD Voltage all pins (HBM)	1	-	1000	V
Pin_Tx_max	Tx input power at TR port		-	+10	dBm
Pin_Rx_max	Rx input power at ANT1 or ANT2 ports		-	+10	dBm

Note: (1) No damage assuming only one parameter is set at limit at a time with all other parameters set at or below the recommended operating conditions.

Recommended Operating Conditions

Symbol	Parameter	Min.	Typ.	Max.	Unit
T _A	Ambient temperature	-40	25	85	°C
VCC	Supply voltage on VCC	2.0	4.0	4.8	V

DATA SHEET
SE2435L: 860 – 930 MHz High Power RF Front End Module

DC Electrical Characteristics

Conditions: VCC = 4.0 V, TA = 25 °C, as measured on Skyworks Solutions' SE2435L-EK1 evaluation board (de-embedded to device), unless otherwise noted

Symbol	Parameter	Conditions	Min.	Typ.	Max.	Unit
ICC-Tx30	Total Supply Current	Tx mode P _{OUT} = 30 dBm CPS = CSD = CTX = HIGH	-	550	-	mA
ICC-Tx27	Total Supply Current	Tx mode P _{OUT} = 27 dBm CPS = CSD = CTX = HIGH	-	380	-	mA
ICC-Tx24	Total Supply Current	Tx mode P _{OUT} = 24 dBm CPS = CSD = CTX = HIGH	-	275	-	mA
ICQ-Tx	Quiescent Current	No RF CPS = CSD = CTX = HIGH	-	50	-	mA
ICC-Rx	Total Supply Current	Rx mode CPS = CSD = HIGH, CTX = 0 V	-	6	-	mA
ICC-RxBypass	Total Supply Current	Rx bypass mode CSD = HIGH, CPS = CTX = 0 V	-	-	280	uA
ICC_OFF	Sleep Supply Current	No RF, CSD= CTX = CPS = 0 V	-	0.05	1	μA

Logic Characteristics

Conditions: TA = 25 °C, as measured on Skyworks Solutions' SE2435L-EK1 evaluation board (de-embedded to device), unless otherwise noted.

Symbol	Parameter	Conditions	Min.	Typ.	Max.	Unit
V _{IH}	Logic input high		1.6	-	VCC	V
V _{IL}	Logic input low		0	-	0.3	V
I _{IH}	Logic input high		-	-	1	μA
I _{IL}	Logic input low		-	-	1	μA

Logic Controls

Conditions: TA = 25 °C

Mode	Mode description	Note	CPS	CSD	CTX
0	All off (sleep mode)	1, 3	0	0	0
1	Rx bypass mode	1, 2	0	1	0
2	Rx LNA mode	1, 2	1	1	0
3	Tx mode	1, 2	X	1	1

- Note:**
- (1) Logic '0' level compliant to V_{IL} as specified in the "Logic Characteristics" table
 - (2) Logic '1' level compliant to V_{IH} as specified in the "Logic Characteristics" table
 - (3) All controls must be at logic '0' in order to achieve the specified sleep current

DATA SHEET
SE2435L: 860 – 930 MHz High Power RF Front End Module

Conditions: $T_A = 25\text{ }^\circ\text{C}$

Mode description	Note	CPS	CSD	CTX	ANT_SEL
ANT1 port enabled	1	X	X	X	0
ANT2 port enabled	2	X	X	X	1

Note: (1) Logic '0' level compliant to V_{IL} as specified in the "Logic Characteristics" table
 (2) Logic '1' level compliant to V_{IH} as specified in the "Logic Characteristics" table

AC Electrical Characteristics, Transmit

Conditions: $V_{CC} = 4.0\text{ V}$, $T_A = 25\text{ }^\circ\text{C}$, as measured on Skyworks Solutions' SE2435L-EK1 evaluation board (de-embedded to device), all unused ports terminated with $50\text{ }\Omega$, unless otherwise noted. Input port TR, output ports ANT1 and ANT2. Lumped elements filter connected between the Tx_FLT and PA_IN pins.

Symbol	Parameter	Condition	Note	Min.	Typ.	Max.	Unit
F_{IN}	Frequency Range			860	-	930	MHz
P_{out_900}	Output power at ANT1 or ANT2 ports in the 900 – 930 MHz frequency range	$V_{CC} = 4.8\text{ V}$ $V_{CC} = 4.0\text{ V}$ $V_{CC} = 3.6\text{ V}$ $V_{CC} = 3.0\text{ V}$	1, 5	-	31.5 30.5 29.5 28.0		dBm
P_{out_860}	Output power at ANT1 or ANT2 ports in the 860 – 870 MHz frequency range	$V_{CC} = 4.0\text{ V}$ $V_{CC} = 3.6\text{ V}$ $V_{CC} = 3.0\text{ V}$ $V_{CC} = 2.0\text{ V}$	2, 5	-	27 24 21 18	-	dBm
PAE	PA Power added efficiency	$P_{out} = 28\text{ dBm}$ at PA_OUT port, 915 MHz			64		%
S_{21_900}	Small Signal Gain	900 – 930 MHz	1	26	-	-	dB
S_{21_860}	Small Signal Gain	860 – 870 MHz	2	26	-	-	dB
ΔS_{21}	Small Signal Gain Variation	Gain variation across frequency range	1, 2	-	-	2	dBp-p
$S_{22_{ANT1,2}}$	Output Return Loss	Into $50\text{ }\Omega$, ANT1 and ANT2 ports	1, 2	-	-10	-6	dB
HD2	Harmonics	$P_{OUT} = 30\text{ dBm}$	1, 3	-	-	-22	dBc
HD3 – HD10	Harmonics	$P_{OUT} = 30\text{ dBm}$	1, 3	-	-	-72	dBc
T_{ON}	Turn on time		4	-	-	1	us
T_{OFF}	Turn off time		5	-	-	1	us
STAB	Stability	CW, $P_{IN} = 0\text{ dBm}$ 0.1 GHz – 20 GHz Load VSWR = 6:1		All non-harmonically related outputs less than -43 dBm			
RU	Ruggedness	CW, $P_{out} = 30\text{ dBm}$ into 50		No permanent damage			

DATA SHEET
SE2435L: 860 – 930 MHz High Power RF Front End Module

Symbol	Parameter	Condition	Note	Min.	Typ.	Max.	Unit
		Ω , Load VSWR = 10:1					

- Note:** (1) 900 – 930 MHz with specified matching network on the SE2435L-EK1 evaluation board
(2) 860 – 870 MHz with specified matching network on the SE2435L-EK1 evaluation board
(3) Measured with Continuous Wave signal
(4) From 50% of CTX edge to 90% of final RF output power
(5) From 50% of CTX edge to 10% of final RF output power

AC Electrical Characteristics, Receive

Conditions: VCC = 4.0 V, TA = 25 °C, as measured on Skyworks Solutions' SE2435L-EK1 evaluation board (de-embedded to device), all unused ports terminated with 50 Ω , unless otherwise noted. Input port ANT1 or ANT2, output port TR. 0 Ω connected between the Rx_FLT and LNA_IN pins, in lieu of external filters.

Symbol	Parameter	Condition	Note	Min.	Typ.	Max.	Unit
F _{IN}	Frequency Range			860	-	930	MHz
Rx_gain	Receive gain	CPS = CSD = logic '1', CTX = logic '0'	1, 2	14	16	18	dB
NF	Receive noise figure	CPS = CSD = logic '1', CTX = logic '0'	1, 2	-	2	2.5	dB
IIP3	Input 3 rd order intercept	CPS = CSD = logic '1', CTX = logic '0'	1, 2	-5	-2	-	dBm
IP1dB	Input 1-dB compression point	CPS = CSD = logic '1', CTX = logic '0'	1, 2	-15	-12	-	dBm
S11 _{ANT1,2}	Antenna port return loss	Into 50 Ω , ANT1 and ANT2 ports	1, 2	-	-12	-8	dB
T _{ON}	Turn on time		3	-	-	1	us
T _{OFF}	Turn off time		4	-	-	1	us
G _{bp}	Gain in bypass mode	CPS = CTX = logic '0', CSD = logic '1'		-3	-2	-	dB
IP1dB	Input 1-dB compression point in bypass mode	CPS = CTX = logic '0', CSD = logic '1'		10	-	-	dBm

- Note:** (1) 900 – 930 MHz
(2) 860 – 870 MHz
(3) From 50% of CTX edge to 90% of final RF output power
(4) From 50% of CTX edge to 10% of final RF output power

AC Electrical Characteristics, Diversity Antenna Function

Conditions: VCC = 4.0 V, TA = 25 °C, as measured on Skyworks Solutions' SE2435L-EK1 evaluation board (de-embedded to device), all unused ports terminated with 50 Ω , unless otherwise noted.

Symbol	Parameter	Note	Min.	Typ.	Max.	Unit
ISOL _{ANTSW}	Isolation Between ANT1 and ANT2 Ports	1, 2	-	-20	-	dB

DATA SHEET
SE2435L: 860 – 930 MHz High Power RF Front End Module

Symbol	Parameter	Note	Min.	Typ.	Max.	Unit
Tx_ANT1	Insertion loss from TX_IN to ANT1	1, 2	-	0.8	-	dB
Tx_ANT2	Insertion loss from TX_IN to ANT2	1, 2	-	0.8	-	dB
Rx_ANT1	Insertion loss from ANT1 to Rx_FILT	1, 2	-	0.6	-	dB
Rx_ANT2	Insertion loss from ANT2 to Rx_FILT	1, 2	-	0.6	-	dB
TxRx_Tx	Insertion loss from TR to Tx_FILT	1, 2	-	0.5	-	dB
T _{ANT1-ANT2_Tx}	Antenna 1 to Antenna 2 switching time Tx mode	1, 2	-	800	-	nsec
T _{ANT1-ANT2_Rx}	Antenna 1 to Antenna 2 switching time Rx mode	1, 2	-	400	-	nsec

Note: (1) 900 – 930 MHz
(2) 860 – 870 MHz

Package Drawing

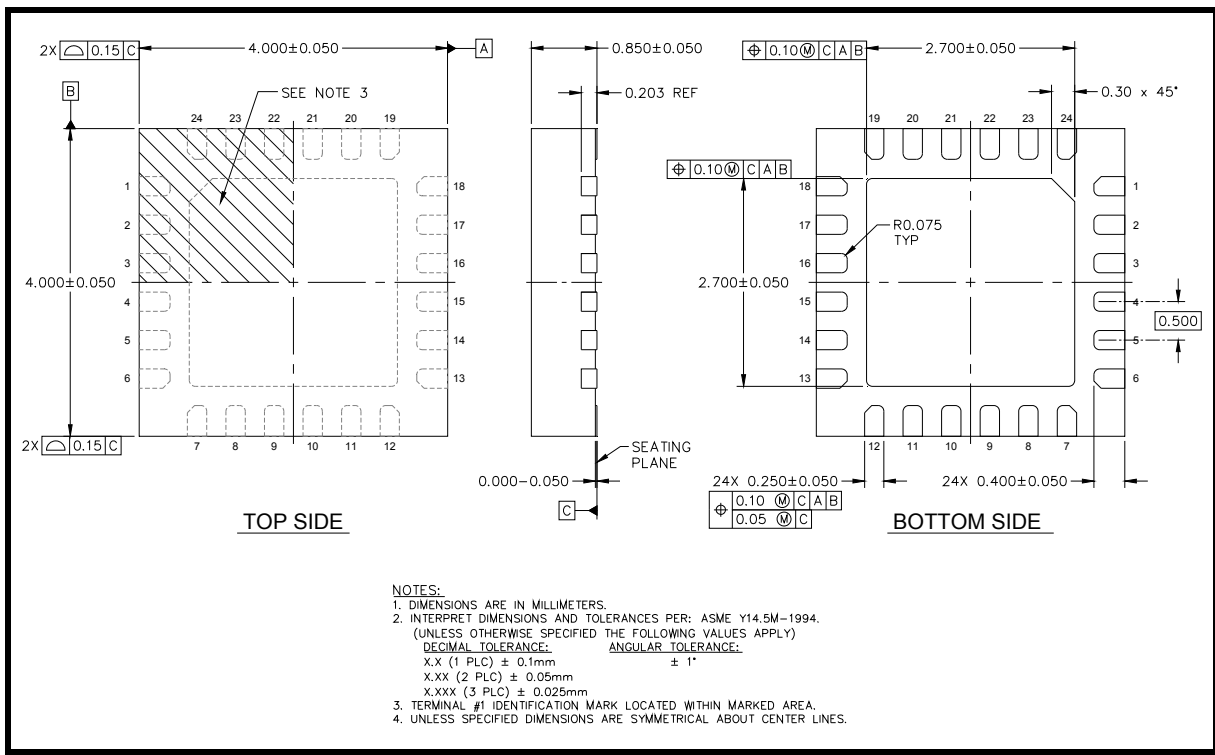

Figure 3: Package Drawing: Topside



DATA SHEET
SE2435L: 860 – 930 MHz High Power RF Front End Module

Tape and Reel Information

Parameter	Value
Devices Per Reel	3000
Reel Diameter	13 inches
Tape Width	12 millimeters

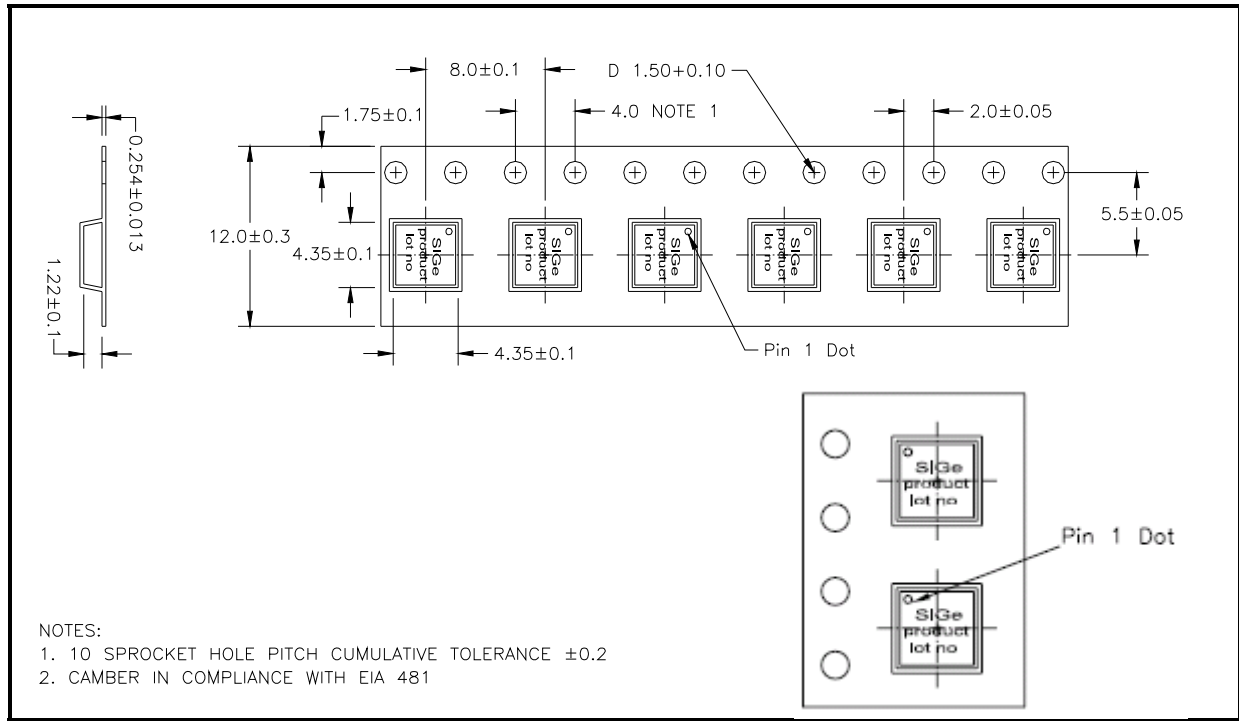

Figure 4: Detailed Tape and Reel Information (All dimensions in Millimeters)

DATA SHEET
SE2435L: 860 – 930 MHz High Power RF Front End Module

Recommended Reflow Temperature Profile

Profile Feature	SnPb Eutectic Assembly	Lead (Pb) Free Assembly
Average Ramp-up Rate (T_L to T_P)	3°C/s (max)	3°C/s (max)
Preheat		
Temperature Min. (T_{smin})	100°C	150°C
Temperature Max. (T_{smax})	150°C	200°C
Time (Min. to Max) (t_s)	60 - 120s	60 - 80s
Ramp Up		
T_{smax} to t_L	-	3°C/s (max)
Time 25°C to Peak Temperature	6 mins. (max)	8 mins. (max)
Reflow		
Temperature (t_L)	183°C	217°C
Time maintained above t_L	60 - 150s	60 - 150s
Peak Temperature (t_p)	240 ±5°C	260 +0/-5°C
Time Within 5°C of Actual Peak Temperature (t_p)	10 - 30s	20 - 40s
Ramp-Down		
Ramp-Down Rate	6°C/s (max)	6°C/s (max)

DATA SHEET
SE2435L: 860 – 930 MHz High Power RF Front End Module

Reflow Profile (Reference JEDEC J-STD-020)

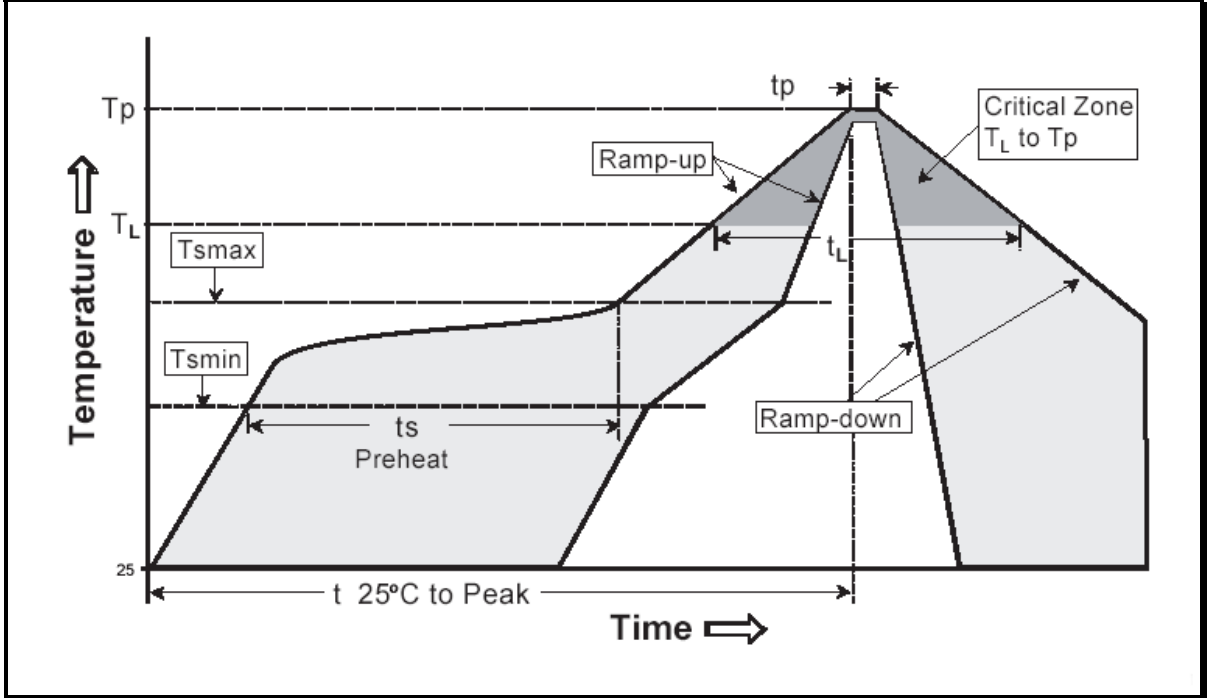

Figure 5: Reflow temperature profile

DATA SHEET
SE2435L: 860 – 930 MHz High Power RF Front End Module

Branding Information

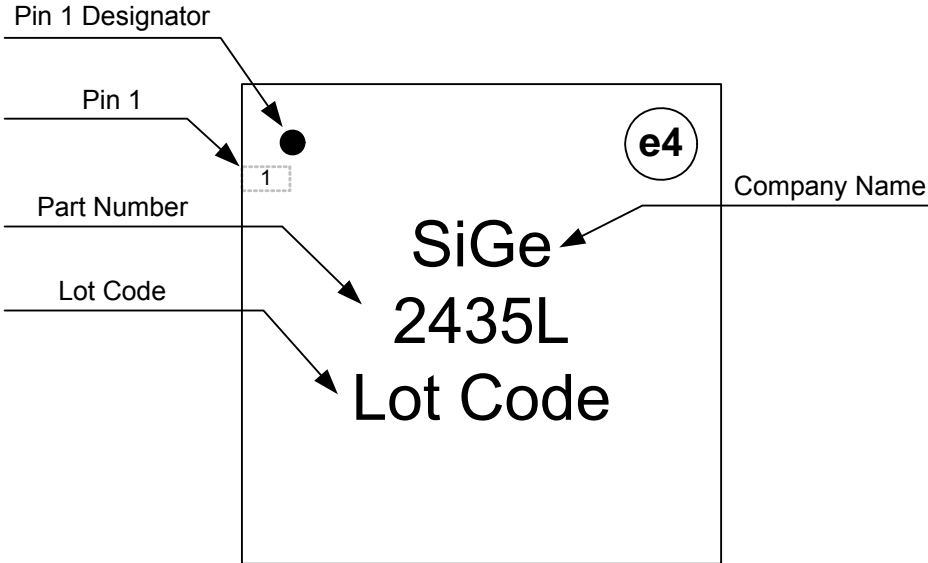

Figure 6: SE2435L Branding

Document Change History

Revision	Date	Notes
1.0	June 11, 2010	Initial release
1.1	July 14, 2010	Updated pinout description
1.2	October 7, 2010	General updates and corrections
1.3	November 5, 2010	Update harmonics limits to reflect compliance with FCC and ETSI
1.4	December 2, 2010	Added specs for PA PAE. Updated package branding
1.5	August 21, 2011	Updated parameters according to final product characterization
1.6	April 10, 2012	Updated with Skyworks logo and disclaimer statement



DATA SHEET

SE2435L: 860 – 930 MHz High Power RF Front End Module

Copyright © 2012 Skyworks Solutions, Inc. All Rights Reserved.

Information in this document is provided in connection with Skyworks Solutions, Inc. ("Skyworks") products or services. These materials, including the information contained herein, are provided by Skyworks as a service to its customers and may be used for informational purposes only by the customer. Skyworks assumes no responsibility for errors or omissions in these materials or the information contained herein. Skyworks may change its documentation, products, services, specifications or product descriptions at any time, without notice. Skyworks makes no commitment to update the materials or information and shall have no responsibility whatsoever for conflicts, incompatibilities, or other difficulties arising from any future changes.

No license, whether express, implied, by estoppel or otherwise, is granted to any intellectual property rights by this document. Skyworks assumes no liability for any materials, products or information provided hereunder, including the sale, distribution, reproduction or use of Skyworks products, information or materials, except as may be provided in Skyworks Terms and Conditions of Sale.

THE MATERIALS, PRODUCTS AND INFORMATION ARE PROVIDED "AS IS" WITHOUT WARRANTY OF ANY KIND, WHETHER EXPRESS, IMPLIED, STATUTORY, OR OTHERWISE, INCLUDING FITNESS FOR A PARTICULAR PURPOSE OR USE, MERCHANTABILITY, PERFORMANCE, QUALITY OR NON-INFRINGEMENT OF ANY INTELLECTUAL PROPERTY RIGHT; ALL SUCH WARRANTIES ARE HEREBY EXPRESSLY DISCLAIMED. SKYWORKS DOES NOT WARRANT THE ACCURACY OR COMPLETENESS OF THE INFORMATION, TEXT, GRAPHICS OR OTHER ITEMS CONTAINED WITHIN THESE MATERIALS. SKYWORKS SHALL NOT BE LIABLE FOR ANY DAMAGES, INCLUDING BUT NOT LIMITED TO ANY SPECIAL, INDIRECT, INCIDENTAL, STATUTORY, OR CONSEQUENTIAL DAMAGES, INCLUDING WITHOUT LIMITATION, LOST REVENUES OR LOST PROFITS THAT MAY RESULT FROM THE USE OF THE MATERIALS OR INFORMATION, WHETHER OR NOT THE RECIPIENT OF MATERIALS HAS BEEN ADVISED OF THE POSSIBILITY OF SUCH DAMAGE.

Skyworks products are not intended for use in medical, lifesaving or life-sustaining applications, or other equipment in which the failure of the Skyworks products could lead to personal injury, death, physical or environmental damage. Skyworks customers using or selling Skyworks products for use in such applications do so at their own risk and agree to fully indemnify Skyworks for any damages resulting from such improper use or sale.

Customers are responsible for their products and applications using Skyworks products, which may deviate from published specifications as a result of design defects, errors, or operation of products outside of published parameters or design specifications. Customers should include design and operating safeguards to minimize these and other risks. Skyworks assumes no liability for applications assistance, customer product design, or damage to any equipment resulting from the use of Skyworks products outside of stated published specifications or parameters.

Skyworks, the Skyworks symbol, and "Breakthrough Simplicity" are trademarks or registered trademarks of Skyworks Solutions, Inc., in the United States and other countries. Third-party brands and names are for identification purposes only, and are the property of their respective owners. Additional information, including relevant terms and conditions, posted at www.skyworksinc.com, are incorporated by reference.