

DS600

±0.5 Accurate Analog-Output Temperature Sensor

www.maxim-ic.com

GENERAL DESCRIPTION

The DS600 is a ±0.5°C accurate analog-output temperature sensor. This accuracy is valid over its entire operating voltage range of 2.7V to 5.5V and the wide temperature range of -20°C to +100°C. The DS600 can also act as a thermostat, with user-programmable trip points. A shutdown mode enables the DS600 to be placed in a low-power standby state. The DS600 is available in an 8-pin μSOP package.

APPLICATIONS

Cold-Junction Thermocouple Compensation
 Portable Medical Equipment
 Thermally Sensitive Systems that Require a High-Accuracy Analog-Output Temperature Sensor

TYPICAL OPERATING CIRCUIT

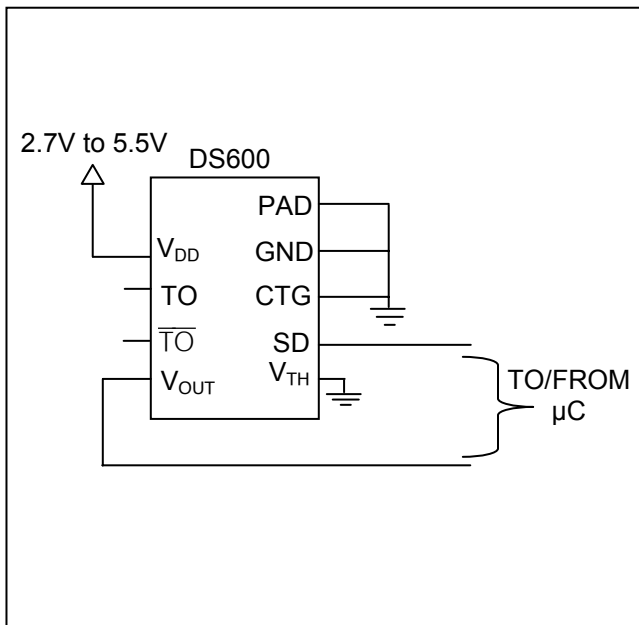

FEATURES

- ±0.5°C Accuracy (-20°C to +100°C)
- ±0.75°C Accuracy Over Entire Temperature Range of -40°C to +125°C
- Requires No External Components
- 6.45mV/°C Output Gain with 509mV Offset at 0°C
- 2.7V to 5.5V Supply Voltage Range
- User-Programmable Thermostat Function
- Shutdown Function Puts Device into a Low-Power Standby Mode
- Exposed Pad 8-Pin μSOP Package for Quick Thermal Response

ORDERING INFORMATION

PART	TEMP RANGE	PIN-PACKAGE
DS600U	-40°C to +125°C	Exposed Pad 8 μSOP
DS600U+	-40°C to +125°C	Exposed Pad 8 μSOP
DS600U/T&R	-40°C to +125°C	Exposed Pad 8 μSOP Tape-and-Reel
DS600U+/T&R	-40°C to +125°C	Exposed Pad 8 μSOP Tape-and-Reel

+ Denotes lead-free package.

PIN CONFIGURATION

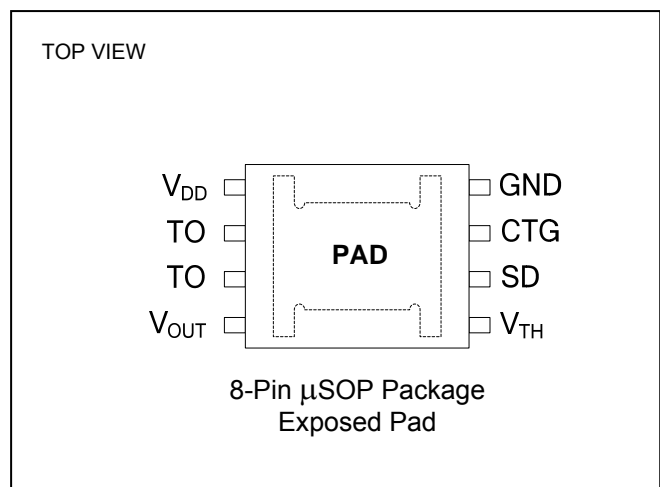

Note: Some revisions of this device may incorporate deviations from published specifications known as errata. Multiple revisions of any device may be simultaneously available through various sales channels. For information about device errata, click here: www.maxim-ic.com/errata.

ABSOLUTE MAXIMUM RATINGS

Voltage Range on Any Pin (except CTG) Relative to Ground	-0.5V to +6.0V
Voltage Range on CTG Relative to Ground	-0.5 to +0.5V
Operating Temperature Range	-40°C to +125°C
Storage Temperature Range	-55°C to +125°C
Soldering Temperature (10s)	+260°C (See IPC/JEDEC J-STD-020A)
Reflow Oven Temperature	+220°C

Stresses beyond those listed under "Absolute Maximum Ratings" may cause permanent damage to the device. These are stress ratings only, and functional operation of the device at these or any other conditions beyond those indicated in the operational sections of the specifications is not implied. Exposure to the absolute maximum rating conditions for extended periods may affect device reliability.

DC ELECTRICAL CHARACTERISTICS

($V_{CC} = 2.7V$ to $5.5V$, $T_A = -40^\circ C$ to $+125^\circ C$.)

PARAMETER	SYMBOL	CONDITIONS	MIN	TYP	MAX	UNITS
Supply Voltage	V_{DD}		2.7		5.5	V
Thermometer Error	T_{ERR}	-20°C to +100°C			±0.5	°C
		-40°C to +125°C			±0.75	
Output Gain	$\Delta V/\Delta T$			6.45		mV/°C
V_{OUT} DC Offset	V_{OS}	0°C		509		mV
Low-Level Input Voltage (SD)	V_{IL}		-0.5		$0.3 \times V_{DD}$	V
High-Level Input Voltage (SD)	V_{IH}		$0.7 \times V_{DD}$		$V_{DD} + 0.5$	V
SD Input Capacitance	C_{SD}			5		pF
VTH Input Capacitance	C_{VTH}			5		pF
Low-Level Output Voltage (TO, \overline{TO})	V_{OL}	4mA sink current	0		0.4	V
Supply Current	I_{DD}				140	µA
Shutdown Current	I_{SD}				2.5	µA
Input Current (V_{TH})	I_{TH}			0.01	1	µA
Input Resistance (V_{TH})	R_{TH}		5			MΩ
Leakage Current (SD)	I_L			0.01	1	µA
External Load Capacitance on V_{OUT}	C_{EL}				50	pF
V_{OUT} Source Current	I_{OSO}		10			µA
V_{OUT} Sink Current	I_{OSI}		10			µA
Output Impedance (V_{OUT})	R_{OUT}				100	Ω
Power-Up Time	$t_{POWERUP}$				10	ms
Nonlinearity					±0.2	°C
Comparator Offset					±3	mV
Comparator Response Time	t_{COMP}				20	ms

PIN DESCRIPTION

PIN	NAME	FUNCTION
1	V_{DD}	Supply Voltage. 2.7V to 5.5V
2	TO	Active-High Thermostat Output. Open-drain output transitions from low to high when the output voltage exceeds V_{TH} . In shutdown mode, (SD = 1), TO is low.
3	\overline{TO}	Active-Low Thermostat Output. Open-drain output transitions from high to low when the output voltage exceeds V_{TH} . In shutdown mode, (SD = 1), \overline{TO} is high.
4	V_{OUT}	Temperature Output. Outputs a voltage that is proportional to the die temperature in degrees centigrade. In shutdown mode, this pin goes high-Z.
5	V_{TH}	Thermostat Trip Voltage. User-selectable voltage that sets the thermostat trip-point temperature. TO and \overline{TO} are asserted when V_{OUT} crosses this voltage. (No on-chip hysteresis is present).
6	SD	Shutdown. Power consumption and thermal sensor function are controlled through SD. This pin functions as an active-high input pin. Driving this pin high puts the device in a low-power state and discontinues thermal sensing.
7	CTG	Must be connected to GND.
8	GND	Ground.
	PAD	PAD. Connect to GND or float. DO NOT CONNECT TO SUPPLY. The exposed pad is the best way to conduct temperature into the package. Connecting PAD to a ground plane can assist in properly measuring the temperature of the circuit board.

Figure 1. Block Diagram

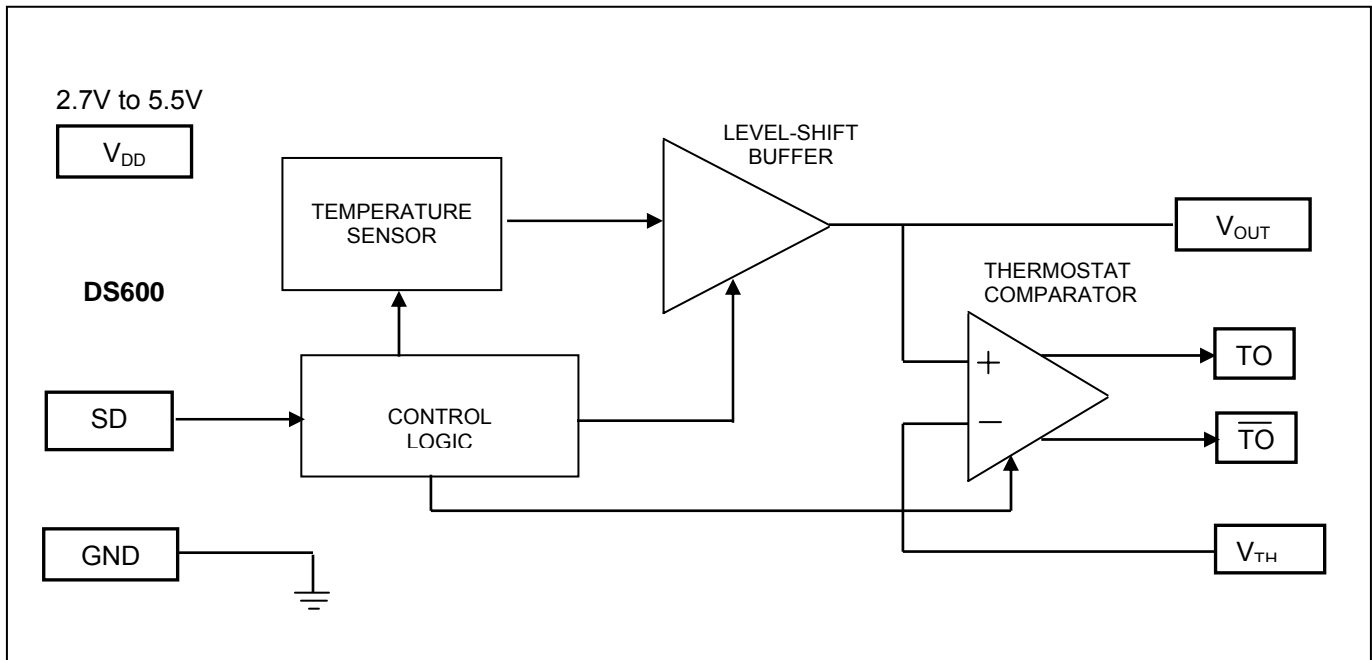

TEMPERATURE MEASUREMENT

The DS600 analog temperature sensor measures its own temperature and provides these measurements to the user in the form of an output voltage, V_{OUT} , that is proportional to degrees centigrade. The output voltage characteristic is factory-calibrated for a typical output gain ($\Delta V/\Delta T$) of $+6.45\text{mV}/^{\circ}\text{C}$ and a DC offset (V_{OS}) of 509mV . Its operating temperature range is -40°C to $+125^{\circ}\text{C}$, corresponding to an output voltage range of 251mV to 1315mV . ($V_{OUT} = \text{Device Temperature } (^{\circ}\text{C}) \times \Delta V/\Delta T + V_{OS}$). The DS600 has $\pm 0.5^{\circ}\text{C}$ accuracy over a -20°C to $+100^{\circ}\text{C}$ temperature range and over the full 2.7V to 5.5V voltage range. Because the output voltage is positive for the entire temperature range, there is no need for a negative supply.

Figure 2 shows the output voltage characteristic for the DS600.

Figure 2. Output Voltage Characteristic

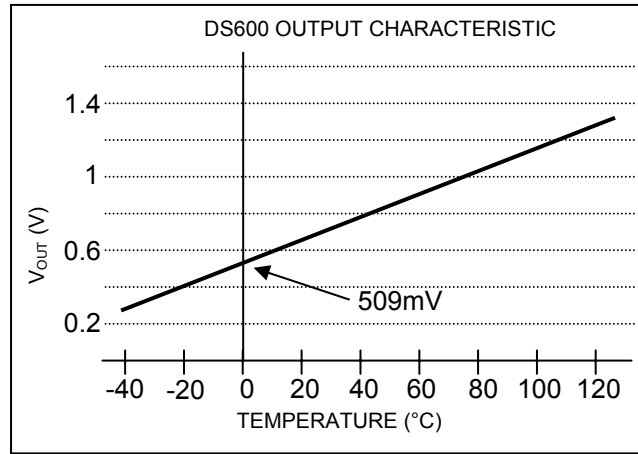

THERMOSTAT OPERATION

The DS600 can also be used as a thermostat with either an active-high (TO) or active-low ($\overline{\text{TO}}$) output. To function as a thermostat, a precise voltage reference equal to the desired threshold must be applied to the V_{TH} pin. When the temperature with the equivalent voltage value is reached (voltage on V_{OUT} = voltage on V_{TH}), thermostat outputs TO and $\overline{\text{TO}}$ become active. Figure 3 shows an example thermostat application circuit.

Figure 3. Thermostat Application Circuit

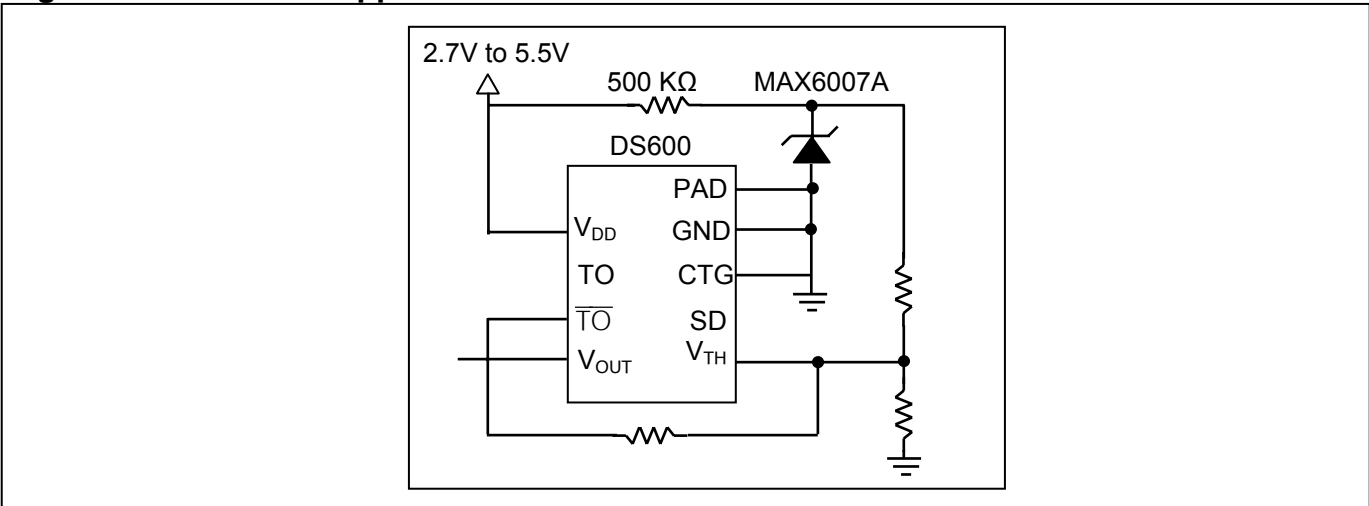

PACKAGE INFORMATION

For the latest package outline information, go to www.maxim-ic.com/DallasPackInfo.

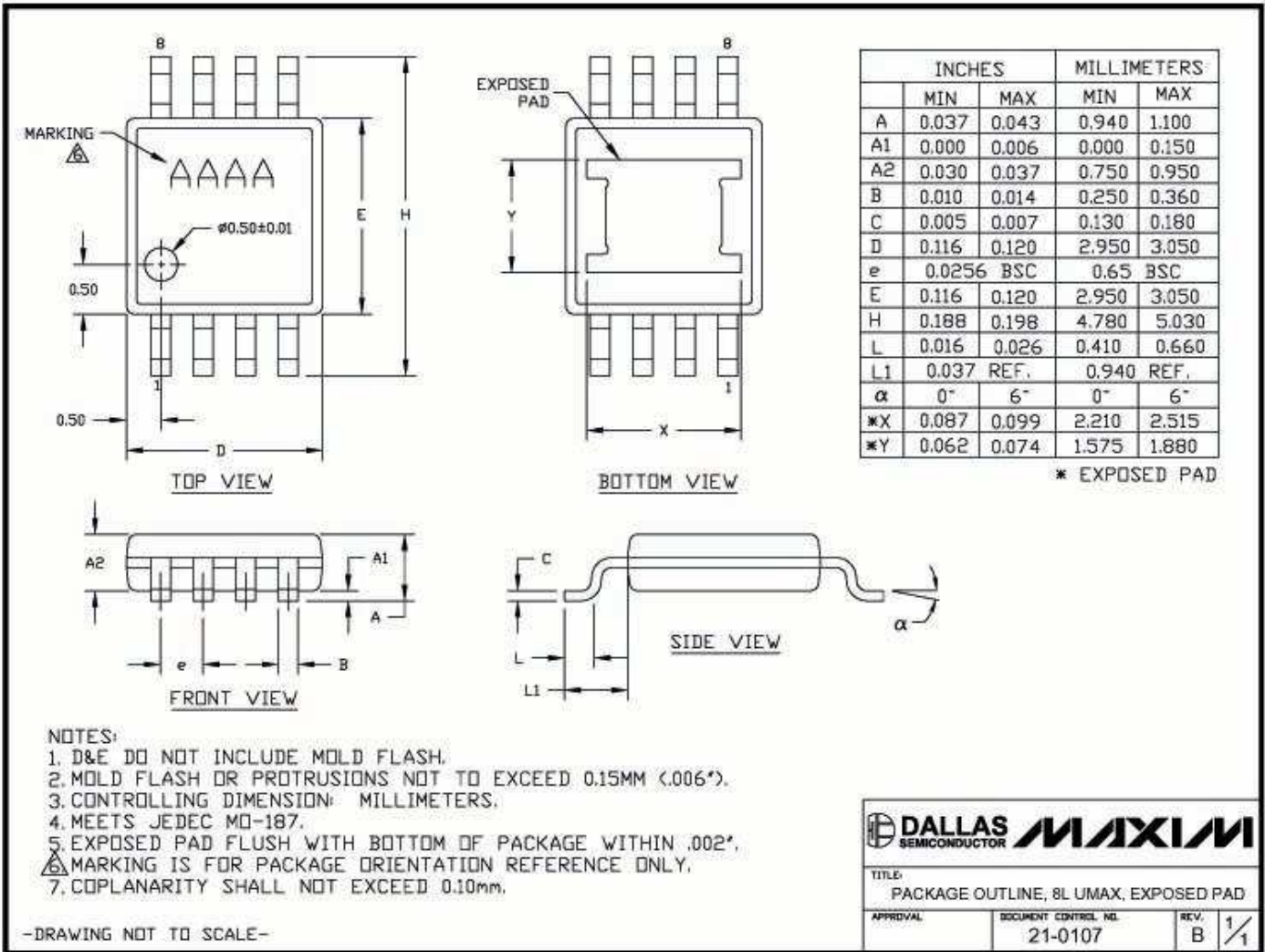

Maxim/Dallas Semiconductor cannot assume responsibility for use of any circuitry other than circuitry entirely embodied in a Maxim/Dallas Semiconductor product. No circuit patent licenses are implied. Maxim/Dallas Semiconductor reserves the right to change the circuitry and specifications without notice at any time.

Maxim Integrated Products, 120 San Gabriel Drive, Sunnyvale, CA 94086 408-737-7600

© 2007 Maxim Integrated Products • Printed USA