



FEATURES:

- SMD package
- Wide (2:1) input range
- 1500VDC isolation
- Continuous short circuit protection
- Operating temperature: -40°C to +85°C
- Regulated single/dual output
- MTBF>1,000,000 hours
- RoHS compliant



Models
Single output

Model	Input Voltage (V)	Output Voltage (V)	Output Current max (mA)	Isolation (VDC)	Efficiency (%)
AM3LV-1205S-NZ	9-18	5	600	1500	74
AM3LV-1212S-NZ	9-18	12	250	1500	78
AM3LV-1215S-NZ	9-18	15	200	1500	80
AM3LV-2405S-NZ	18-36	5	600	1500	76
AM3LV-2412S-NZ	18-36	12	250	1500	80
AM3LV-2415S-NZ	18-36	15	200	1500	80
AM3LV-4805S-NZ	36-72	5	600	1500	76
AM3LV-4812S-NZ	36-72	12	250	1500	80
AM3LV-4815S-NZ	36-72	15	200	1500	80

Models
Dual output

Model	Input Voltage (V)	Output Voltage (V)	Output Current max (mA)	Isolation (VDC)	Efficiency (%)
AM3LV-1205D-NZ	9-18	±5	±300	1500	76
AM3LV-1212D-NZ	9-18	±12	±125	1500	80
AM3LV-1215D-NZ	9-18	±15	±100	1500	80
AM3LV-2405D-NZ	18-36	±5	±300	1500	76
AM3LV-2412D-NZ	18-36	±12	±125	1500	80
AM3LV-2415D-NZ	18-36	±15	±100	1500	80
AM3LV-4805D-NZ	36-72	±5	±300	1500	76
AM3LV-4812D-NZ	36-72	±12	±125	1500	80
AM3LV-4815D-NZ	36-72	±15	±100	1500	80

NOTE: Unless otherwise specified, all specifications are measured at an ambient temperature of 25°C, humidity<75%, nominal input voltage and at rated output load.

Input Specifications

Parameters	Nominal	Typical	Maximum	Units
Voltage range	12	9-18		VDC
	24	18-36		
	48	36-72		
Absolute Maximum Rating	12		22	VDC
	24		40	
	48		80	
Peak Input Voltage time			100	ms

Isolation Specifications

Parameters	Conditions	Typical	Rated	Units
Tested I/O voltage	60 sec		1500	VDC
Resistance	At 500 Vdc	1000		MOhm
Capacitance	Input to Output	1000		pF

Output Specifications

Parameters	Conditions	Typical	Maximum	Units
Voltage accuracy		±5		%
Short Circuit protection		Continuous		
Short circuit restart		Auto-Recovery		
Line voltage regulation (Single)	From Low in to High In	±0.5		%
Load voltage regulation (Single)	From 10% to 100% load	±1		%
Load voltage regulation (Dual)	From 10% to 100% load Unbalanced load	±5		%
Temperature coefficient		±0.03		%/°C
Ripple & Noise *	20MHz Bandwidth	100		mV p-p
Minimum Load Current**		10		% of Max

* Converters are designed to operate with a minimum load of 10%. If converter is operated with a load less than 10% the ripple will increase.

** Operation under 10% load will not damage the converter; However, not all specifications will be met.

General Specifications

Parameters	Conditions	Typical	Maximum	Units
Switching frequency	100% load	300		KHz
Operating temperature		-40 to +85		°C
Storage temperature		-55 to +125		°C
Maximum case temperature			100	°C
Derating	Above 71°	2.9		%/°C
Cooling		Free Air Convection		
Humidity			95	% RH
Case material		Epoxy resin (UL94-V0 rated)		
Weight		5.2		g
Dimensions (L x W x H)		0.94 x 0.54 x 0.34 inches	23.86 x 13.70 x 8.50 mm	
MTBF		>1,000,000 hours (MIL-HDBK -217F, Ground Benign, t=+25°C)		
Maximum Soldering Temperature	1.5mm from case for 10 seconds		245	°C

Pin Out Specifications

Pin	Single	Dual
1	- Vin	- Vin
7	NC	NC
8	NC	Common
9	+Vout	+Vout
10	- Vout	-Vout
16	+ Vin	+ Vin

NC – not connected

Dimensions

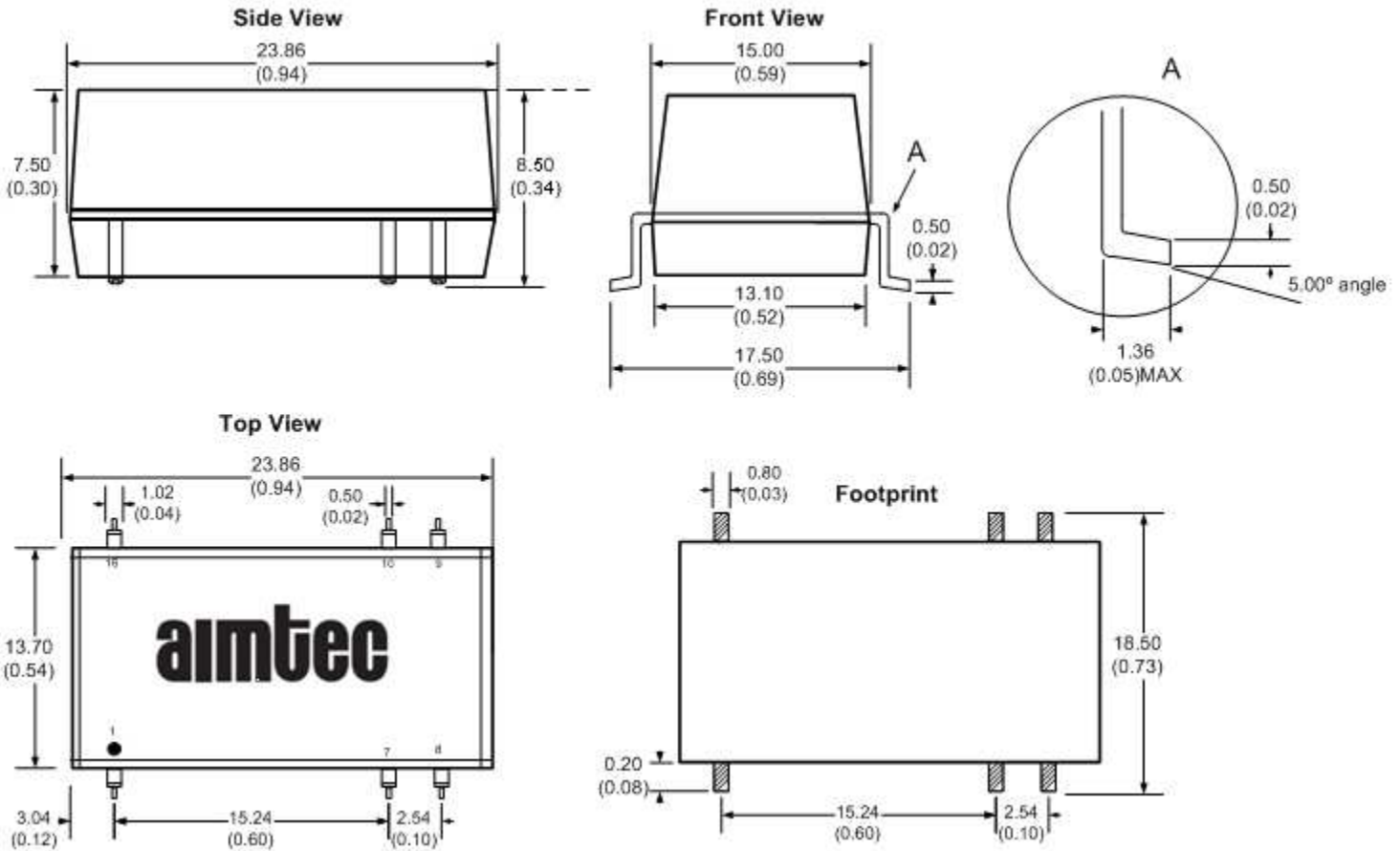

Recommended Filter Circuit

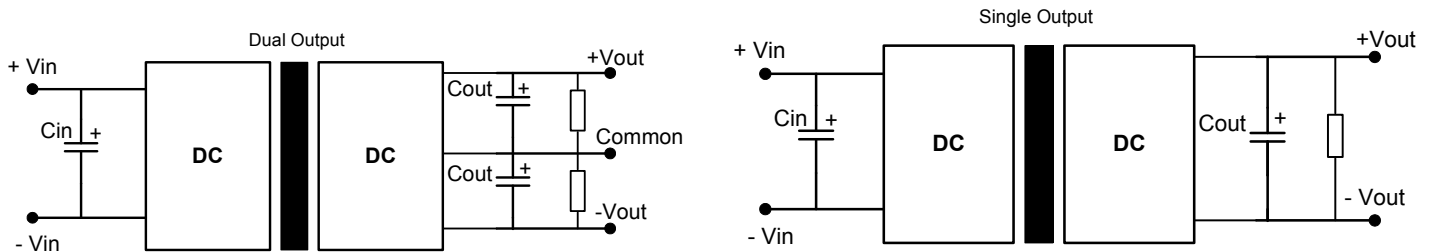

All the AM3LV-Z Series have been tested with the above recommended test circuit. This series should be tested under load.

If it is necessary to further decrease the input/output ripple, the value of the filter capacitor can be increased; a capacitor with a low ESR should be used. Excessive filter capacitance can cause start up problems with the converter.

In general, the recommended capacitance values are:

Cin: 12V input 100 μ F, 24V&48V input 10 μ F~47 μ F

Cout: 10 μ F/100mA

Refer to table below for maximum capacitor values:

External Capacitor Value

Single Output Vout (VDC)	Cout (uF)	Dual Output Vout (VDC)	Cout (uF)
5	1000	±5	±680
12	470	±12	±330
15	330	±15	±220

Derating

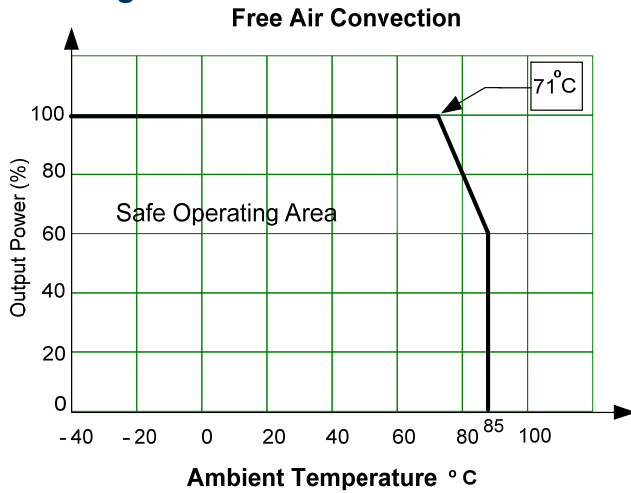

NOTE: 1. Datasheets are updated as needed and as such, specifications are subject to change without notice. Once printed or downloaded, datasheets are no longer controlled by Aimtec; refer to www.aimtec.com for the most current product specifications. 2. Product labels shown, including safety agency certifications on labels, may vary based on the date manufactured. 3. Mechanical drawings and specifications are for reference only. 4. All specifications are measured at an ambient temperature of 25°C, humidity<75%, nominal input voltage and at rated output load unless otherwise specified. 5. Aimtec may not have conducted destructive testing or chemical analysis on all internal components and chemicals at the time of publishing this document. CAS numbers and other limited information are considered proprietary and may not be available for release. 6. This product is not designed for use in critical life support systems, equipment used in hazardous environments, nuclear control systems or other such applications which necessitate specific safety and regulatory standards other the ones listed in this datasheet. 7. Warranty is in accordance with Aimtec's standard Terms of Sale available at www.aimtec.com.