

## FEATURES

- Single 8-position Log Trimmer Potentiometer  
5-dB/step
- Operates from 2.7V to 5.5V supplies
- Parallel interface control: P0, P1, P2
- Standard Resistance Value: 10 k $\Omega$
- 8-pin DIPs; 8-pin (150) SOICs
- Operating Temperature Range:
  - Industrial: -40°C to +85°C

## PIN ASSIGNMENT

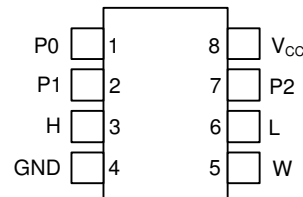

8-Pin DIP (300-mil)  
See Mech. Drawings Section

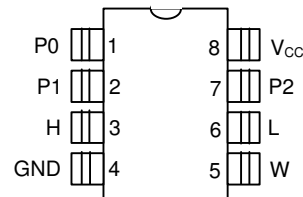

8-Pin SOIC (150-mil)  
See Mech. Drawings Section

## PIN DESCRIPTION

H	- High End of Resistor
L	- Low End of Resistor
W	- Wiper Terminal
V <sub>CC</sub>	- 3V or 5V Power Supply Input
P0	- Position Select - Bit 0
P1	- Position Select - Bit 1
P2	- Position Select - Bit 2
GND	- Ground

## DESCRIPTION

The DS1866 Log Trimmer Potentiometer is a single volatile digital potentiometer having eight positions with a 5-dB resolution per step. The device provides an ideal method for low-cost trimming or volume control using a CPU or manual control input. The device's wiper position is set to one of eight positions by a 3-terminal parallel port. The value of the wiper position is determined by the P0, P1, and P2 port pins.

The DS1866 is available as a 10k potentiometer and is available in an industrial temperature grade. Additionally, the DS1866 will operate from 3V or 5V supplies and is ideal for portable applications requiring low standby current. Two packaging options are available and include the 8-pin (300-mil) DIP, 8-pin (150-mil) SOIC.

## OPERATION

The DS1866 is a single volatile potentiometer. The device has a total of eight positions providing a resolution of 5 dB per step and giving a total attenuation range of 0 dB to -35 dB. These tap points are accessible to the W-terminal whose position is controlled via a 3-terminal parallel port consisting of input signals P0, P1, and P2. A block diagram of the DS1866 is shown in Figure 1.

Wiper position setting of the DS1866 is determined by the states of the P0, P1, and P2 input terminals. Table 1 below outlines position setting versus value of the parallel port inputs. A Position-0 setting places the wiper position at the L-terminal of the potentiometer and provides 35 dB of attenuation. As wiper position increases, attenuation decreases with Position-7 giving 0 dB of attenuation.

On power-up, the wiper position of the DS1866 will be set to the P0, P1, and P2 values.

<b>P2 P1 P0 (binary)</b>	<b>Wiper Position</b>	<b>Attenuation (dB)</b>
000	0	35 dB
001	1	30 dB
010	2	25 dB
011	3	20 dB
100	4	15 dB
101	5	10 dB
110	6	5 dB
111	7	0 dB

## PIN DESCRIPTIONS

**V<sub>CC</sub> - Power Supply Terminal.** The DS1866 will support supply voltages ranging from +2.7 to +5.5 volts.

**GND - Ground Terminal.**

**H - High-end Resistor.** This is the high-end terminal of the potentiometer. It is not required that this terminal be connected to a potential greater than the L-terminal. Maximum voltage on the H-terminal can not exceed the power supply voltage, V<sub>CC</sub>, or go below ground.

**L - Low-end Resistor.** This is the low-end terminal of the potentiometer. It is not required that this terminal be connected to a potential less than the H-terminal. Maximum voltage on the L-terminal can not exceed the power-supply voltage, V<sub>CC</sub>, or go below ground.

**W - Wiper of the Potentiometer.** This pin is the wiper terminal of the potentiometer. Its position on the resistor array is controlled by the 3-terminal parallel port. Maximum voltage on the W-terminal can not exceed the power supply voltage, V<sub>CC</sub>, or go below ground.

**P0 - Bit 0.** P0 is the bit 0 data input to the parallel port.

**P1 - Bit 1.** P1 is the bit 1 data input to the parallel port.

**P2 - Bit 2.** P2 is the bit 2 data input to the parallel port.

**One Time Programmability (OTP).** The DS1866 can be easily used as an OTP device. This can be accomplished by terminating the P0, P1, or P2 to desired logic levels during system manufacturing. On power up, the value of P0, P1, and P2 will then set the wiper position setting of the DS1866.

### DS1866 BLOCK DIAGRAM Figure 1

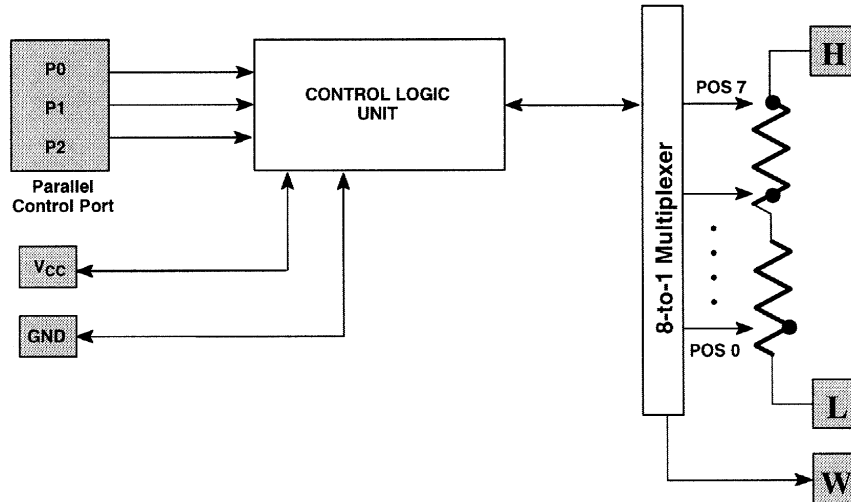

**ABSOLUTE MAXIMUM RATINGS\***

Voltage on Any Pin Relative to Ground	-0.5V to +7.0V
Operating Temperature	-40°C to +85°C
Storage Temperature	-55°C to +125°C
Soldering Temperature	260°C for 10 seconds

\* This is a stress rating only and functional operation of the device at these or any other conditions above those indicated in the operation sections of this specification is not implied. Exposure to absolute maximum rating conditions for extended periods of time may affect reliability.

**RECOMMENDED DC OPERATING CONDITIONS** (-40 °C to +85 °C)

PARAMETER	SYMBOL	MIN	TYP	MAX	UNITS	NOTES
Supply Voltage	V <sub>CC</sub>	+2.7		5.5	V	1
Input Logic 1	V <sub>IH</sub>	2.0		V <sub>CC</sub> +0.5	V	1, 2
Input Logic 0	V <sub>IL</sub>	-0.5		+0.8 +0.6	V	1, 2
Ground	GND	GND -0.5		GND +0.5		
Resistor Inputs	L, H, W	GND -0.5		V <sub>CC</sub> +0.5	V	1, 3

**DC ELECTRICAL CHARACTERISTICS** (-40 °C to +85 °C; V<sub>CC</sub> = 2.7V to 5.5V)

PARAMETER	SYMBOL	MIN	TYP	MAX	UNITS	NOTES
Supply Current	I <sub>CC</sub>			400	μA	4
Input Leakage	I <sub>U</sub>	-1		+1	μA	
Wiper Resistance	R <sub>W</sub>		400	1000	Ω	
Wiper Current	I <sub>W</sub>			1	mA	
Standby Current	I <sub>STBY</sub>					
3 volts			10		μA	5
5 volts			25	50	μA	

**ANALOG RESISTOR CHARACTERISTICS** (-40 °C to +85 °C; V<sub>CC</sub> = 2.7V to 5.5V)

PARAMETER	SYMBOL	MIN	TYP	MAX	UNITS	NOTES
End to End Resistor Tolerance		-20		+20	%	6
Absolute Tolerance		-1.0		+1.0	dB	8
Tap-to-Tap		-1.0		+1.0	dB	9
-3 dB Cutoff Frequency	f <sub>CUTOFF</sub>		1 MHz		MHz	10
Temperature Coefficient			750		ppm/°C	

**CAPACITANCE** (25 °C; V<sub>CC</sub> = 2.7V to 5.5V)

PARAMETER	SYMBOL	MIN	TYP	MAX	UNITS	NOTES
Input Capacitance	C <sub>IN</sub>			5	pF	11
Output Capacitance	C <sub>OUT</sub>			7	pF	11

**AC ELECTRICAL CHARACTERISTICS** (-40 °C to +85 °C; V<sub>CC</sub> = 2.7V to 5.5V)

PARAMETER	SYMBOL	MIN	TYP	MAX	UNITS	NOTES
Parallel Port Transition	t <sub>PC</sub>			500	ns	12

**NOTES:**

1. All voltages are referenced to ground.
2. For  $V_{CC} = 5V \pm 10\%$  maximum  $V_{IL} = +0.8V$ . For  $V_{CC} 3.0 \pm 10\%$   $V_{IL} = +0.6V$ . For  $V_{CC} = 2.7$  volts  $V_{IH} = 2.0$  volts minimum.
3. Resistor input voltages cannot go below ground or exceed  $V_{CC}$  by the amounts as shown in the table.
4. Maximum current specifications are based on the change rate of the parallel port inputs P0, P1, and P2.
5. Standby current specifications apply when P0, P1, P2 logic inputs are driven within the specified  $V_{IH}$  or  $V_{IL}$  levels.
6. Valid at 25°C only.
7. The end-to-end resistance tolerance of the DS1866 can be expected to shift with temperature. However, this change will not exceed  $\pm 20\%$  of the nominal resistor value of the part.
8. Absolute tolerance is used to compare measured wiper voltage versus expected wiper voltage as determined by wiper position. The DS1866 is specified to provide an absolute tolerance of  $\pm 1.0$  dB.
9. Tap-to-tap tolerance is used to determine the change in voltage between successive tap positions. The DS1866 is specified to provide a tap-to-tap tolerance specification of  $\pm 1.0$  dB.
10. -3 dB cutoff frequency characteristic for the DS1866 is 1 MHz.
11. Capacitance values apply at 25°C.
12. This specification refers to the time difference between parallel port input changes to stabilize a wiper transition.

**DS1866 ORDERING INFORMATION**

ORDERING NUMBER	PACKAGE	OPERATING TEMPERATURE	VERSION
DS1866	8L DIP	-40°C TO +85°C	10k $\Omega$
DS1866Z	8L SOIC (150-MIL)	-40°C TO +85°C	10k $\Omega$