

DATA SHEET
SE2614BT: 2.4 GHz High Efficiency Wireless LAN Front End
Preliminary

Applications

- IEEE802.11b DSSS WLAN
- IEEE802.11g,n OFDM WLAN
- Access Points, PCMCIA, PC cards

Features

- Dual Mode IEEE802.11b, IEEE802.11g, IEEE802.11n
- Integrated PA, TX Filter, SP3T switch
- Integrated Positive Slope Power Detector
- 20 dBm Output Power, 802.11b, 11 Mbps
- 18 dBm @ 3.0 % EVM, 802.11g, 3.3V
- Lead free, halogen free and RoHS compliant
- Small plated package, 3 mm x 3 mm x 0.6 mm, MSL 1

Product Description

The SE2614BT is a complete 802.11bgn WLAN RF front-end module providing all the functionality of the power amplifier, power detector, SP3T Switch and 50 ohm matching on all RF ports in an ultra compact form factor.

The SE2614BT is designed for ease of use, with all the critical matching and harmonic filtering integrated. The SE2614BT also includes a transmitter power detector with 20 dB of dynamic range and a digital enable control for transmitter power on/off control. The power ramp rise/fall time is 0.1 μ s typical.

Ordering Information

Part No.	Package	Remark
SE2614BT	20 lead QFN	Samples
SE2614BT-R	20 lead QFN	Tape & Reel
SE2614BT-EK1	N/A	Evaluation kit

Functional Block Diagram

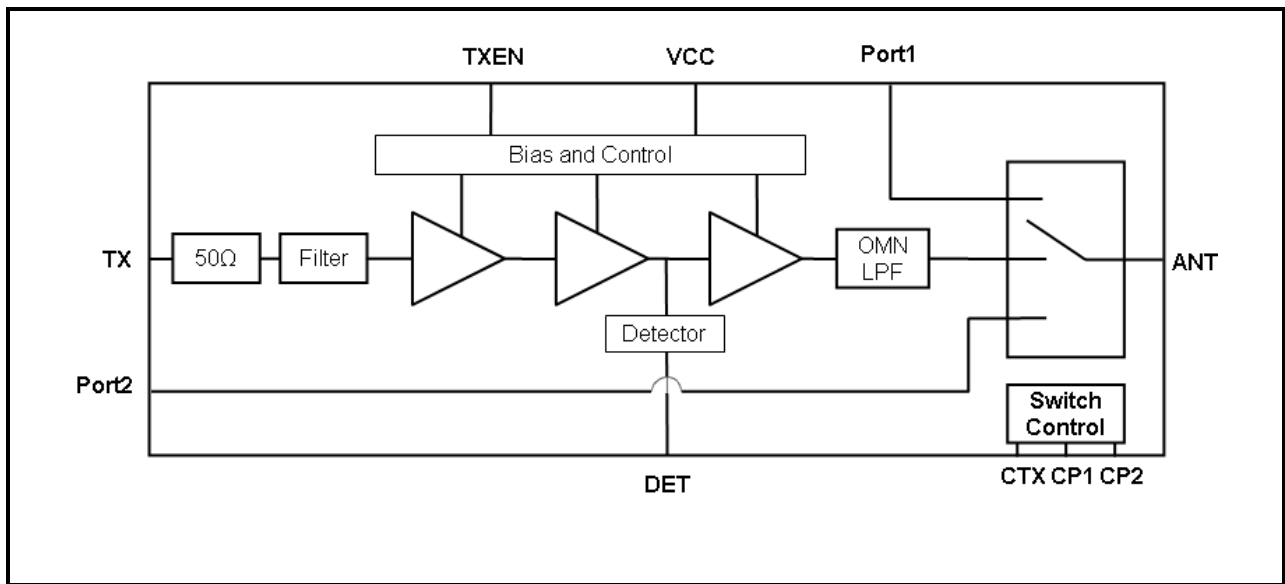

Figure 1: Functional Block Diagram

DATA SHEET
SE2614BT: 2.4 GHz High Efficiency Wireless LAN Front End
Preliminary

Pin Out Diagram

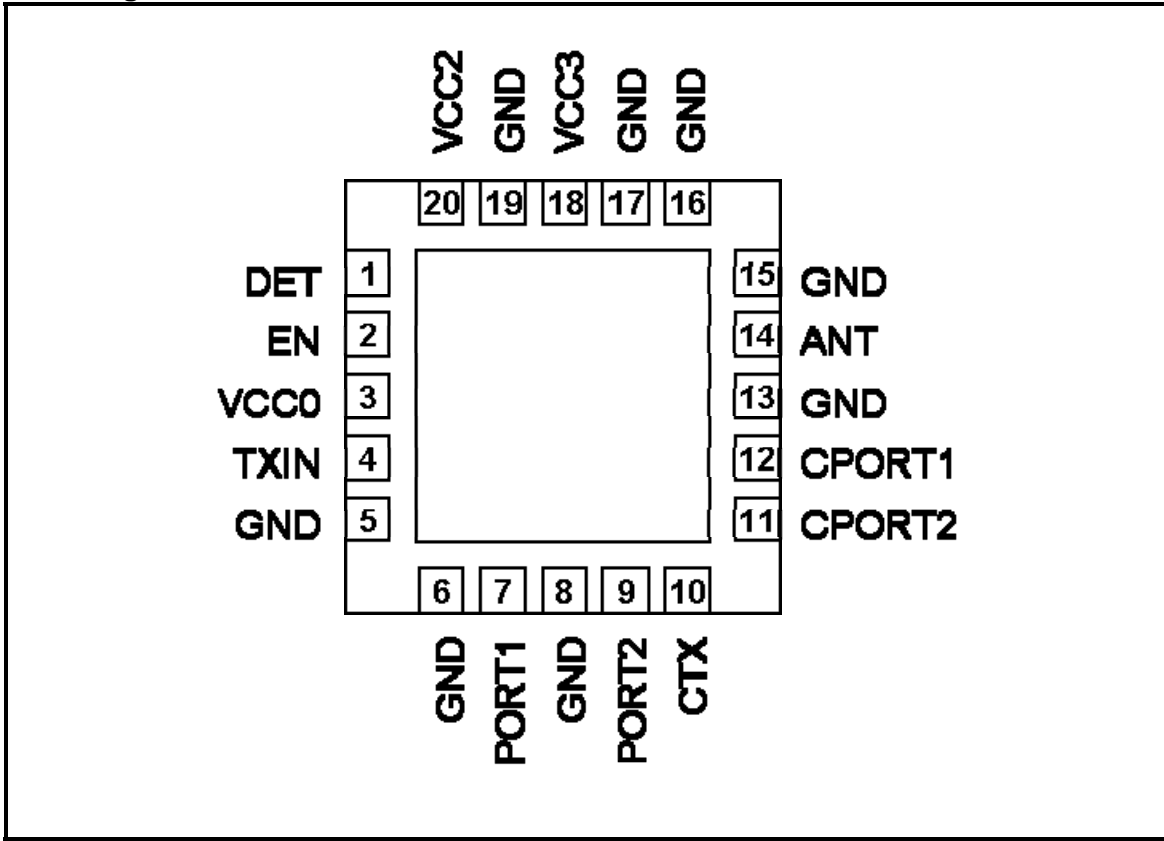

Figure 2: SE2614BT Pin Out (Top View Through Package)

Pin Out Description

Pin	Name	Description
1	DET	Power Detector output
2	EN	TX Enable
3	VCC0	Supply Voltage – Pre-driver & Driver
4	TXIN	TX input
5	GND	Ground
6	GND	Ground
7	PORT1	Port 1 – May be used for RX or BT
8	GND	Ground
9	PORT2	Port 2 – May be used for RX or BT
10	CTX	Switch Control Logic – TX path

Pin	Name	Description
11	CPORT2	Switch Control Logic – Port 2 path
12	CPORT1	Switch Control Logic – Port 1 path
13	GND	Ground
14	ANT	Antenna Output
15	GND	Ground
16	GND	Ground
17	GND	Ground
18	Vcc3	Supply Voltage Power Stage
19	GND	Ground
20	Vcc2	Supply Voltage

DATA SHEET
SE2614BT: 2.4 GHz High Efficiency Wireless LAN Front End
Preliminary

Absolute Maximum Ratings

These are stress ratings only. Exposure to stresses beyond these maximum ratings may cause permanent damage to, or affect the reliability of the device. Avoid operating the device outside the recommended operating conditions defined below. This device is ESD sensitive. Handling and assembly of this device should be at ESD protected workstations.

Symbol	Definition	Min.	Max.	Unit
VCC	Supply Voltage on VCC	-0.3	3.6	V
V _{IN}	DC input on EN, CTX, CPORT1, CPORT2	-0.3	3.6	V
TX	RF Input Power.	-	12.0	dBm
T _A	Operating Temperature Range	-40	85	°C
T _{STG}	Storage Temperature Range	-40	150	°C
ESD _{HBM}	JEDEC JESD22-A114 all pins to Ground	-	1	KV

Recommended Operating Conditions

Symbol	Parameter	Min.	Typ.	Max.	Unit
T _A	Ambient temperature	-40	25	85	°C
VCC	VCC0, VCC2, VCC3, supply voltage	3.0	3.3	3.6	V

DC Electrical Characteristics

Conditions: VCC = EN = 3.3 V, T_A = 25 °C, as measured on Skyworks Solutions' SE2614BT-EK1 evaluation board, all unused ports terminated with 50 ohms, unless otherwise noted

Symbol	Parameter	Conditions	Min.	Typ.	Max.	Unit
I _{CC-G}	Total Supply Current	P _{OUT} = 18 dBm, 54 Mbps OFDM signal, 64QAM	-	160	-	mA
I _{CC-B}	Total Supply Current	P _{OUT} = 20 dBm, 11 Mbps CCK signal, BT = 0.45	-	190	-	mA
I _{CC}	Total Supply Current	No RF	-	90	-	mA
I _{cntl}	Control Line Current	CTX, CPORT2, CPORT1 = 3.3V	-	1	10	μA
I _{CC_OFF}	Total Supply Current	No RF Applied, EN = CTX = CPORT1 = CPORT2 = 0 V	-	1	10	μA

DATA SHEET
SE2614BT: 2.4 GHz High Efficiency Wireless LAN Front End
Preliminary

PA Logic Characteristics

Conditions: VCC = EN = 3.3 V, TA = 25 °C, as measured on Skyworks Solutions' SE2614BT-EK1 evaluation board, all unused ports terminated with 50 ohms, unless otherwise noted.

Symbol	Parameter	Conditions	Min.	Typ.	Max.	Unit
V _{ENH}	Logic High Voltage (Module On)	-	1.6	3.3	3.6	V
V _{ENL}	Logic Low Voltage (Module Off)	-	0	-	0.4	V
I _{ENH}	Input Current Logic High Voltage	-	-	330	400*	μA
I _{ENL}	Input Current Logic Low Voltage	-	-	2	10	μA

*due to on chip pulldown resistor

Switch Logic Characteristics

Conditions: VCC = EN = 3.3 V, TA = 25 °C, as measured on Skyworks Solutions' SE2614BT-EK1 evaluation board (de-embedded to device), all unused ports terminated with 50 ohms, unless otherwise noted.

Symbol	Parameter	Conditions	Min.	Typ.	Max.	Unit
V _{CTL_ON}	Control Voltage (On State)	-	1.6	3.3	3.6	V
V _{CTL_OFF}	Control Voltage (OFF State)	-	0.0	-	0.4	V
T _{switch}	T/R Switching Speed	V _{CTL_OFF} -> V _{CTL_ON} V _{CTL_ON} -> V _{CTL_OFF}		200	-	nSec
C _{CTL}	Control Input Capacitance	-	-	-	1	pF

Switch Control Logic Table

Allowed Switch Logic					
CPORT1	CPORT2	CTX	PORT1 – ANT	PORT2 – ANT	TX-ANT
ON	OFF	OFF	ON	OFF	OFF
OFF	ON	OFF	OFF	ON	OFF
OFF	OFF	ON	OFF	OFF	ON
All Other States			Not Supported		

DATA SHEET
SE2614BT: 2.4 GHz High Efficiency Wireless LAN Front End
Preliminary

AC Electrical Characteristics

802.11g/n Transmit Characteristics

Conditions: VCC = EN = CTX = 3.3 V, CPORT1 = CPORT2 = 0 V, T_A = 25 °C, as measured on Skyworks Solutions' SE2614BT-EK1 evaluation board, all unused ports terminated with 50 ohms, unless otherwise noted.

Symbol	Parameter	Condition	Min.	Typ.	Max.	Unit
F _{IN}	Frequency Range	-	2400	-	2500	MHz
P _{OUT}	Output Power	54 Mbps OFDM signal, 64 QAM, 3% EVM	-	18	-	dBm
ACPR, IEEE Mask	Spectral Mask	P _{OUT} = 20 dBm, 11 Mbps CCK, BT = 0.45 11 – 22 MHz 22 – 33 MHz	-	-35 -55	-	dBc
P _{1dB}	P1dB	-	-	25	-	dBm
S ₂₁	Small Signal Gain	-	-	30	-	dB
ΔS _{21_T}	Small Signal Gain vs Temp	Measured at single freq from -40°C to 85°C	-1.5		+1.5	dB
ΔS ₂₁	Small Signal Gain Variation	Gain variation over single 40MHz channel	-	0.5	-	dB
		Gain Variation over band	-	1.1	-	
S _{213.2}	Gain @ limit 3.2Ghz	3206 to 3312 MHz	-	10	15	dB
2f	Harmonics	P _{OUT} = 20 dBm, 1 Mbps, DSSS	-	-50	-45	dBm/MHz
3f			-	-50	-45	dBm/MHz
t _{dr} , t _{df}	Delay and rise/fall Time	50 % of V _{EN} edge and 90/10 % of final output power level	-	0.2	-	μs
S ₁₁	Input Return Loss	-	-	10	-	dB
STAB	Stability	CW, P _{OUT} = 20 dBm 0.1 GHz – 20 GHz Load VSWR = 6:1	All non-harmonically related outputs less than -42 dBm/MHz			
RU	Ruggedness	P _{IN} = 12dBm, Load VSWR = 6:1	No permanent damage			

DATA SHEET
SE2614BT: 2.4 GHz High Efficiency Wireless LAN Front End
Preliminary

Receive and BT Characteristics

Conditions: VCC = 3.3 V, EN = CTX = 0 V, TA = 25 °C, as measured on Skyworks Solutions' SE2614BT-EK1 evaluation board, all unused ports terminated with 50 ohms, unless otherwise noted.

Symbol	Parameter	Condition	Min.	Typ.	Max.	Unit
F _{OUT}	Frequency Range	-	2400	-	2500	MHz
RX _{IL}	Insertion Loss	CPORT1 = 0 V and CPORT2 = 3.3 V or CPORT1 = 3.3 V and CPORT2 = 0 V	-	1.2	-	dB
RX _{RL}	Return Loss	PORT1 or PORT2	15	20	-	dB
BT _{IL}	Insertion Loss	-	-	1.2	-	
BT _{RL}	Return Loss	PORT1 or PORT2	15	20	-	dB
T _{on/off}	T/R on/off switching speed	Switching speed between T/R modes. V _{cc0} =3.3V.		200	250	nSec
ANTR _{ISOL}	Isolation between ANT and PORT1/PORT2	Difference in signal level on PORT1 or PORT2 when transmitting from TX. CTX = 3.3V, CPORT1 = CPORT2 = 0V PORT1 and PORT2 terminated in 50ohm.	-	25	-	dB

DATA SHEET
SE2614BT: 2.4 GHz High Efficiency Wireless LAN Front End
Preliminary

Power Detector Characteristics

Conditions: $V_{CC} = EN = CTX = 3.3\text{ V}$, $C_{PORT1} = C_{PORT2} = 0\text{ V}$, $T_A = 25\text{ }^\circ\text{C}$, as measured on Skyworks Solutions' SE2614BT-EK1 evaluation board, unless otherwise noted.

Symbol	Parameter	Condition	Min.	Typ.	Max.	Unit
F_{OUT}	Frequency Range	-	2400	-	2500	MHz
PDR	Power detect range, CW	Measured at ANT	0	-	21	dBm
PDV_{NoRF}	Output Voltage, $P_{OUT} = \text{No RF}$	Measured into 26K Ω	-	0.35	-	V
PDV_{P18}	Output Voltage, $P_{OUT} = 18\text{ dBm CW}$	Measured into 26K Ω	-	0.68	-	V
PDV_{P21}	Output Voltage, $P_{OUT} = 22\text{ dBm CW}$	Measured into 26K Ω	-	0.83	-	V
Z_{out}	Detector output impedance			1		K Ω
LPF_{-3dB}	Power detect low pass filter -3dB corner frequency	$PDC_{LOAD} = \text{High Z (1M}\Omega\text{)}$	-	500	-	KHz

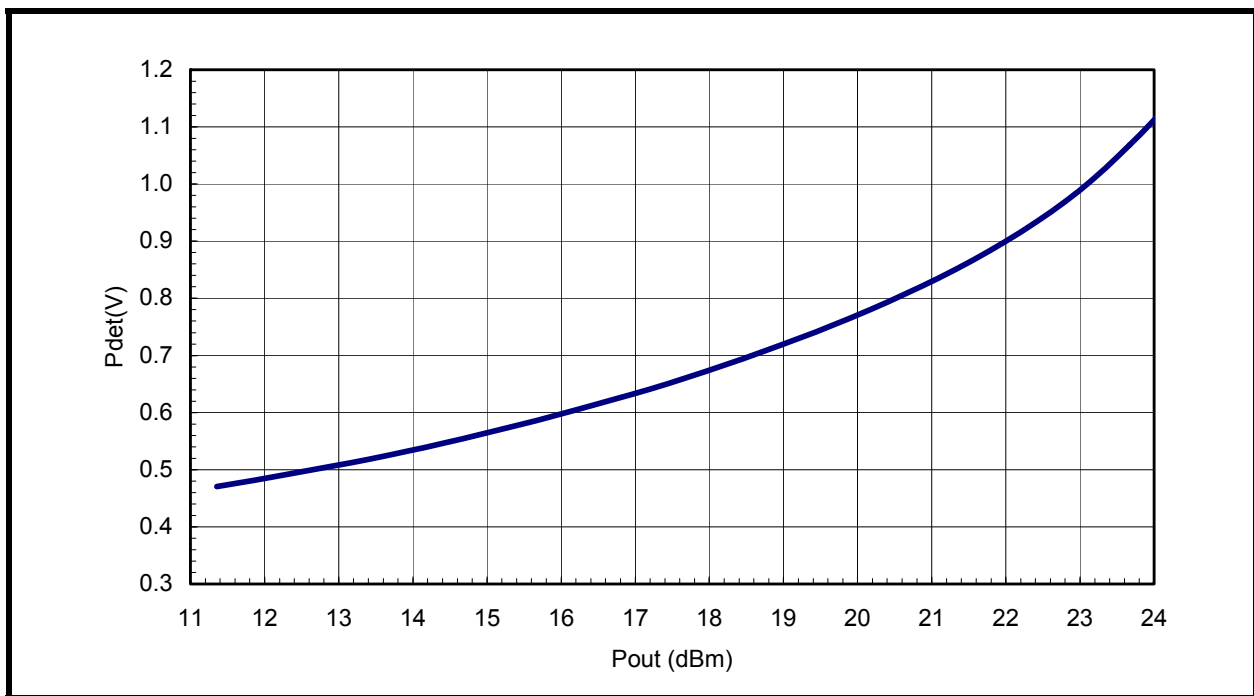

Figure 3: SE2614BT Power Detector Characteristics



SKYWORKS®

DATA SHEET
SE2614BT: 2.4 GHz High Efficiency Wireless LAN Front End
Preliminary

Package Diagram

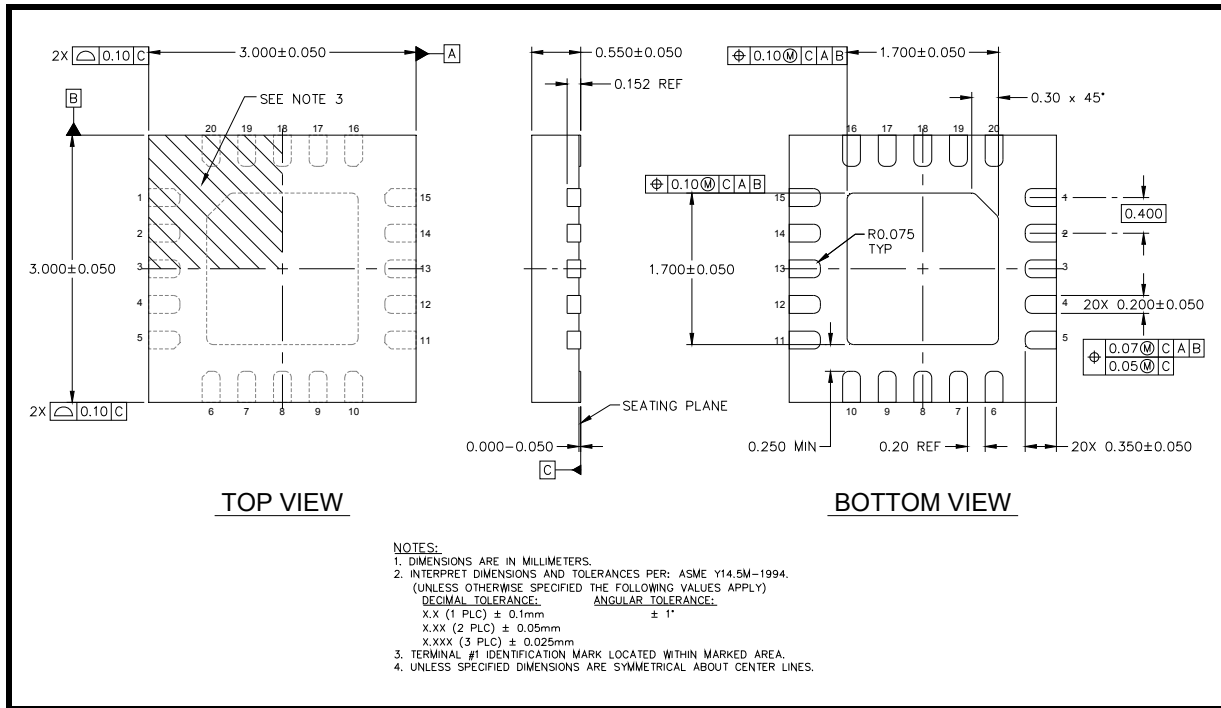

Figure 4: SE2614BT Package Outline Drawing

DATA SHEET
SE2614BT: 2.4 GHz High Efficiency Wireless LAN Front End
Preliminary

Recommended Land and Solder Patterns

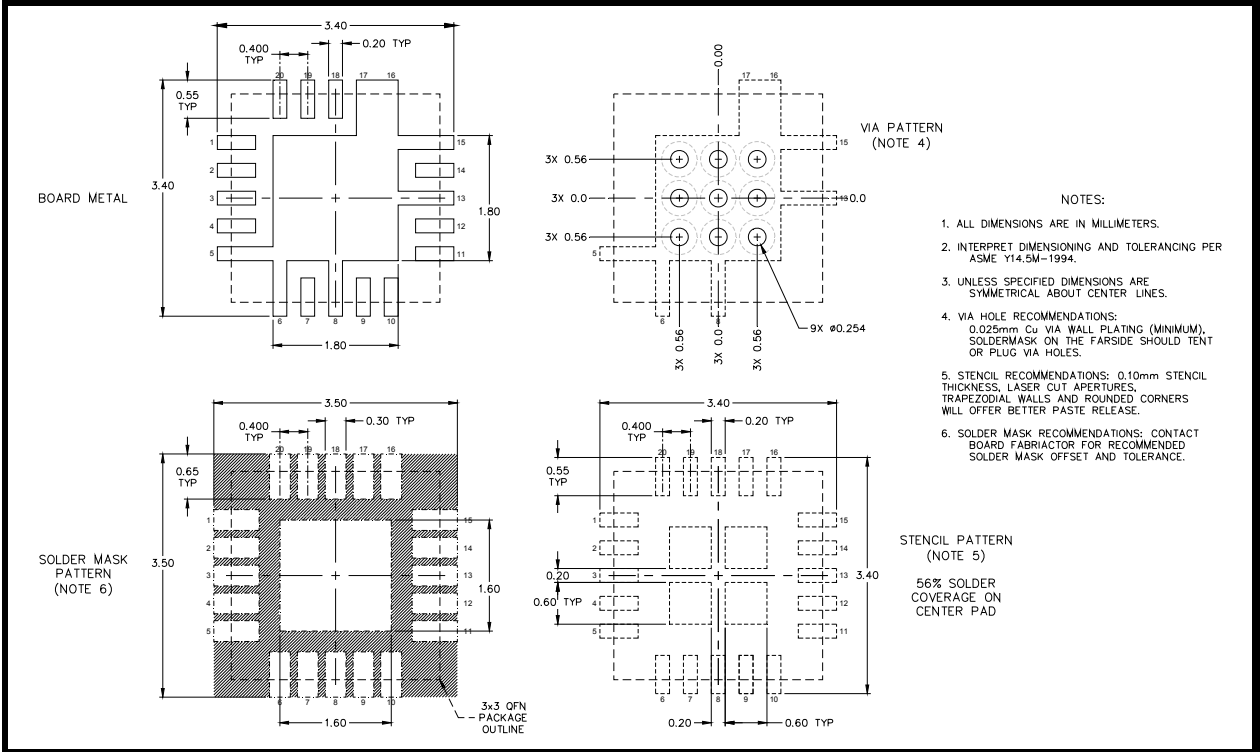

Figure 5: Recommended Land and Solder Patterns

DATA SHEET
SE2614BT: 2.4 GHz High Efficiency Wireless LAN Front End
Preliminary

Package Handling Information

Because of its sensitivity to moisture absorption, instructions on the shipping container label must be followed regarding exposure to moisture after the container seal is broken, otherwise, problems related to moisture absorption may occur when the part is subjected to high temperature during solder assembly. The SE2614BT is capable of withstanding a Pb free solder reflow. Care must be taken when attaching this product, whether it is done manually or in a production solder reflow environment. If the part is manually attached, precaution should be taken to insure that the device is not subjected to temperatures above its rated peak temperature for an extended period of time. For details on both attachment techniques, precautions, and handling procedures recommended, please refer to:

- “Quad Flat No-Lead Module Solder Reflow & Rework Information”, *Document Number QAD-00045*
- “Handling, Packing, Shipping and Use of Moisture Sensitive QFN”, *Document Number QAD-00044*



Caution! ESD sensitive device

Branding Information

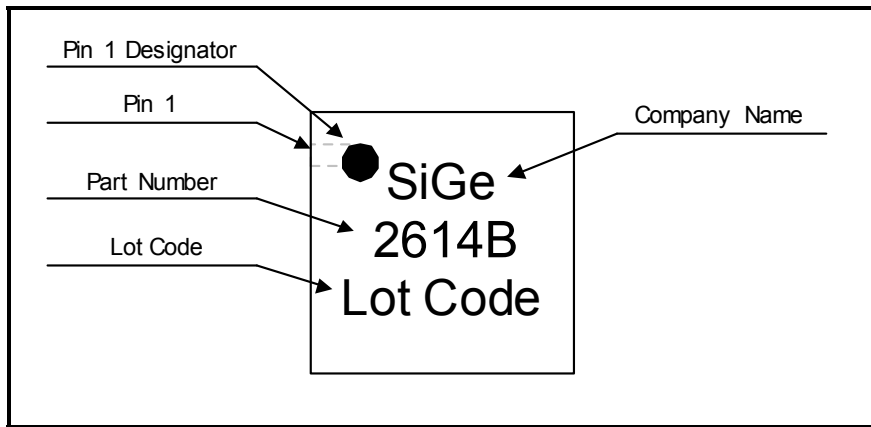

Figure 6: SE2614BT Branding Information

Tape and Reel Information

Parameter	Value
Devices Per Reel	3000
Reel Diameter	13 inches
Tape Width	12 millimeters

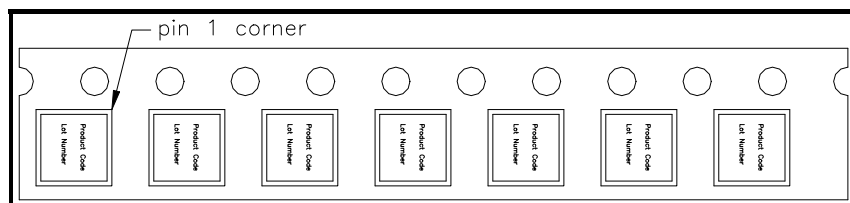

Figure 7: SE2614BT-R Tape and Reel Information



DATA SHEET
SE2614BT: 2.4 GHz High Efficiency Wireless LAN Front End
Preliminary

Document Change History

Revision	Date	Notes
1.0	January 17, 2011	Created
1.1	February 3, 2011	Updated MSL rating and landing pattern.
1.2	June 15, 2011	Updated ESD rating to 1KV
1.3	April 3, 2012	Updated with Skyworks logo and disclaimer statement

Copyright © 2012 Skyworks Solutions, Inc. All Rights Reserved.

Information in this document is provided in connection with Skyworks Solutions, Inc. ("Skyworks") products or services. These materials, including the information contained herein, are provided by Skyworks as a service to its customers and may be used for informational purposes only by the customer. Skyworks assumes no responsibility for errors or omissions in these materials or the information contained herein. Skyworks may change its documentation, products, services, specifications or product descriptions at any time, without notice. Skyworks makes no commitment to update the materials or information and shall have no responsibility whatsoever for conflicts, incompatibilities, or other difficulties arising from any future changes.

No license, whether express, implied, by estoppel or otherwise, is granted to any intellectual property rights by this document. Skyworks assumes no liability for any materials, products or information provided hereunder, including the sale, distribution, reproduction or use of Skyworks products, information or materials, except as may be provided in Skyworks Terms and Conditions of Sale.

THE MATERIALS, PRODUCTS AND INFORMATION ARE PROVIDED "AS IS" WITHOUT WARRANTY OF ANY KIND, WHETHER EXPRESS, IMPLIED, STATUTORY, OR OTHERWISE, INCLUDING FITNESS FOR A PARTICULAR PURPOSE OR USE, MERCHANTABILITY, PERFORMANCE, QUALITY OR NON-INFRINGEMENT OF ANY INTELLECTUAL PROPERTY RIGHT; ALL SUCH WARRANTIES ARE HEREBY EXPRESSLY DISCLAIMED. SKYWORKS DOES NOT WARRANT THE ACCURACY OR COMPLETENESS OF THE INFORMATION, TEXT, GRAPHICS OR OTHER ITEMS CONTAINED WITHIN THESE MATERIALS. SKYWORKS SHALL NOT BE LIABLE FOR ANY DAMAGES, INCLUDING BUT NOT LIMITED TO ANY SPECIAL, INDIRECT, INCIDENTAL, STATUTORY, OR CONSEQUENTIAL DAMAGES, INCLUDING WITHOUT LIMITATION, LOST REVENUES OR LOST PROFITS THAT MAY RESULT FROM THE USE OF THE MATERIALS OR INFORMATION, WHETHER OR NOT THE RECIPIENT OF MATERIALS HAS BEEN ADVISED OF THE POSSIBILITY OF SUCH DAMAGE.

Skyworks products are not intended for use in medical, lifesaving or life-sustaining applications, or other equipment in which the failure of the Skyworks products could lead to personal injury, death, physical or environmental damage. Skyworks customers using or selling Skyworks products for use in such applications do so at their own risk and agree to fully indemnify Skyworks for any damages resulting from such improper use or sale.

Customers are responsible for their products and applications using Skyworks products, which may deviate from published specifications as a result of design defects, errors, or operation of products outside of published parameters or design specifications. Customers should include design and operating safeguards to minimize these and other risks. Skyworks assumes no liability for applications assistance, customer product design, or damage to any equipment resulting from the use of Skyworks products outside of stated published specifications or parameters.

Skyworks, the Skyworks symbol, and "Breakthrough Simplicity" are trademarks or registered trademarks of Skyworks Solutions, Inc., in the United States and other countries. Third-party brands and names are for identification purposes only, and are the property of their respective owners. Additional information, including relevant terms and conditions, posted at www.skyworksinc.com, are incorporated by reference.