

DATA SHEET
SE5501L: Dual Band 802.11n WLAN/BT Front End

Applications

- IEEE802.11b DSSS WLAN
- IEEE802.11a,g,n OFDM WLAN
- Embedded applications with Bluetooth (Mobile)

Features

- Direct to Battery operation
- All RF ports matched to 50 Ω
- Integrated 2.4/5 GHz PA, 2.4/5 GHz LNA, T/R switches and filtering
- Integrated Power Detector
- 20 dBm @ 3 % EVM, 802.11gn, 54 Mbps
- 18 dBm @ 3.0 % EVM, 802.11an, 54 Mbps
- Lead free, Halogen Free and RoHS compliant
- Compact package, 3 x 5 x 0.9 mm, MSL 3

Ordering Information

Part No.	Package	Remark
SE5501L	30 pin QFN	Samples
SE5501L-R	30 pin QFN	Tape & Reel
SE5501L-EK1	N/A	Evaluation kit

Product Description

The SE5501L is a complete 802.11n WLAN RF front-end module providing all the functionality of the power amplifiers, LNAs, power detector, Antenna switches, filtering and associated matching. The SE5501L provides a complete 2.4 GHz and 5 GHz WLAN RF solution from the output of the transceiver to the antennas in a compact form factor.

The receive path is designed to maximize performance by providing both a low noise amplifier as well as a bypass state, for use when high power signals are being received.

Designed for ease of use, all RF ports are matched to 50 Ω to simplify PCB layout and the interface to the transceiver RFIC. The SE5501L also includes a transmitter power detector for each band with 20 dB of dynamic range.

The SE5501L is optimized for mobile applications with direct to battery operation

DATA SHEET
SE5501L: Dual Band 802.11n WLAN/BT Front End

Functional Block Diagram

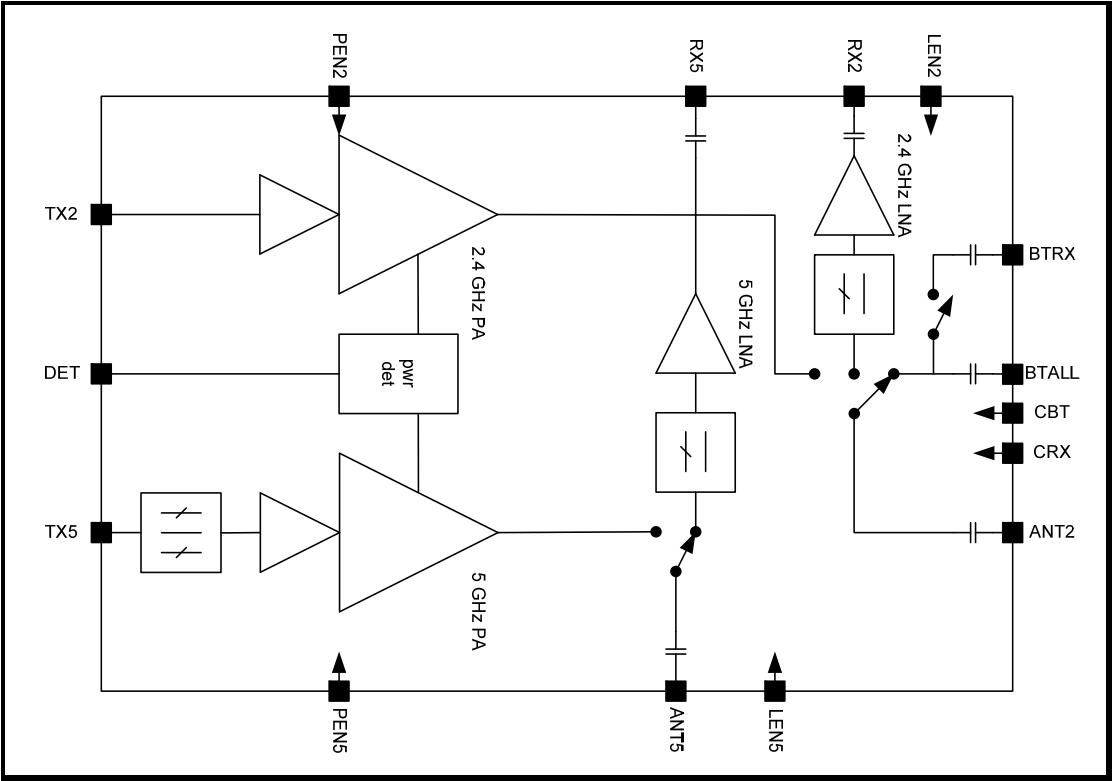

Figure 1: Functional Block Diagram

DATA SHEET
SE5501L: Dual Band 802.11n WLAN/BT Front End

Pin Out Diagram

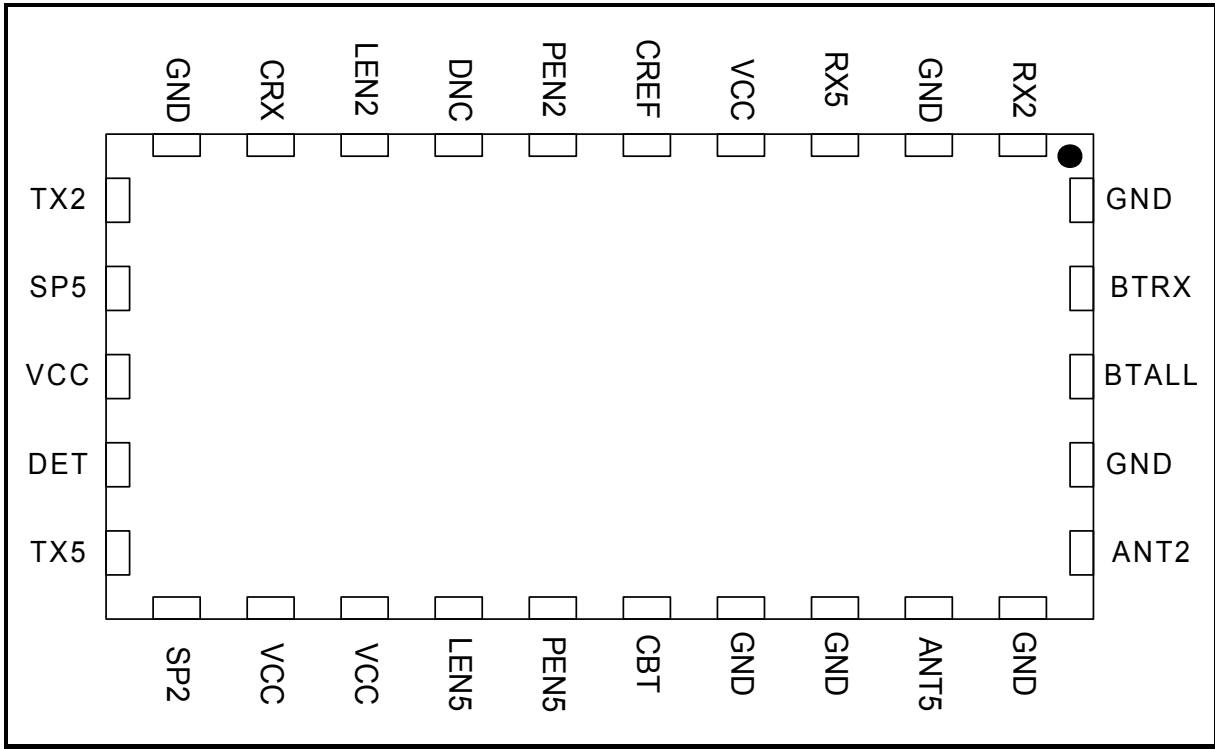

Figure 2: SE5501L Pin Out (Top View Through Package)

Pin Out Description

Pin No.	Name	Description
1	RX2	2.4 GHz RX output
2	GND	Ground
3	RX5	5 GHz RX output
4	VCC	Supply Voltage
5	CREF	Logic Reference Voltage
6	PEN2	Enable for 2.4 GHz PA and TX Switch
7	DNC	Do Not Connect
8	LEN2	Enable for 2.4 GHz LNA and RX Switch
9	CRX	Switch control for RX Switches
10	GND	Ground
11	TX2	2.4 GHz Transmit Port
12	SP5	5 GHz bias speedup
13	VCC	Supply Voltage

Pin No.	Name	Description
14	DET	Power Detector Output
15	TX5	5 GHz Transmit Port
16	SP2	2.4 GHz bias speedup
17	VCC	Supply Voltage
18	VCC	Supply Voltage
19	LEN5	Enable for 5 GHz LNA and RX Switch
20	PEN5	Enable for 5 GHz PA and TX Switch
21	CBT	Switch control for BT
22	GND	Ground
23	GND	Ground
24	ANT5	5 GHz Antenna Port
25	GND	Ground
26	ANT2	2.4 Ghz Antenna Port

DATA SHEET
SE5501L: Dual Band 802.11n WLAN/BT Front End

Pin No.	Name	Description	Pin No.	Name	Description
27	GND	Ground	29	BTRX	BT RX Port
28	BTALL	BT Port	30	GND	Ground

Absolute Maximum Ratings

These are stress ratings only. Exposure to stresses beyond these maximum ratings may cause permanent damage to, or affect the reliability of the device. Avoid operating the device outside the recommended operating conditions defined below. This device is ESD sensitive. Handling and assembly of this device should be at ESD protected workstations.

Symbol	Definition	Min.	Max.	Unit
V _{CC}	Supply Voltage	-0.3	5.5	V
V _{IN}	Control Pin Voltages	-0.3	3.6	V
TX _{RFIN}	TX2/TX5, with ANT2/ANT5 terminated in 50Ω	-	+10	dBm
T _A	Operating Temperature Range	-40	85	°C
T _{STG}	Storage Temperature Range	-40	125	°C
ESD _{HBM}	JEDEC JESD22-A114 All pins		1000	V

Recommended Operating Conditions

Symbol	Parameter	Min.	Typ.	Max.	Unit
V _{CC}	Supply Voltage	3.0	3.3	4.8	V
T _A	Ambient Temperature	-40	25	85	°C

Control Logic Characteristics

Conditions: V_{CC} = 3.3 V, T_A = 25 °C, as measured on Skyworks Solutions' SE5501L-EK1 evaluation board (de-embedded to device), all unused ports terminated with 50 ohms, unless otherwise noted.

DATA SHEET
SE5501L: Dual Band 802.11n WLAN/BT Front End

Parameter	min	nom	max	Units
Logic high reference : VREF	1.7		3.6	V
Logic input high : VIH	VREF-0.3		3.6	V
Logic input low : VIL	0		0.3	V
Logic input current : IIH		0.5	5	μA
Logic input current : IIL		0.1	1	μA

DATA SHEET
SE5501L: Dual Band 802.11n WLAN/BT Front End

DC Electrical Characteristics

Conditions: $V_{CC} = 3.3 V$, $T_A = 25 ^\circ C$, as measured on Skyworks Solutions' SE5501L-EK1 evaluation board (de-embedded to device), all unused ports terminated with 50 ohms, unless otherwise noted

Symbol	Parameter	Conditions	Min.	Typ.	Max.	Unit
TX _{ICC-G}	Total 802.11g Transmit Supply Current	P _{OUT} = 20 dBm, 54 Mbps OFDM signal, 64QAM, PEN2 = Hi,	-	180	190	mA
		P _{OUT} = 18 dBm, 54 Mbps OFDM signal, 64QAM, PEN2 = Hi,		160	170	
TX _{ICQ-G}	Quiescent current , 802.11g Transmit supply Current	No RF applied, PEN2=Hi	-	100	-	mA
TX _{ICC-A}	Total 802.11a Transmit Supply Current	P _{OUT} = 18 dBm, 54 Mbps OFDM signal, 64QAM, PEN5= Hi	-	190	200	mA
		P _{OUT} = 16 dBm, 54 Mbps OFDM signal, 64QAM, PEN5= Hi		170	180	
TX _{ICQ-A}	Quiescent current , 802.11a Transmit supply Current	No RF applied, PEN5- Hi	-	120	-	mA
RX _{ICC-G}	Total 802.11b/g Receive Supply Current	LEN= Hi	-	15		mA
		LEN = Lo		0.2		
RX _{ICC-A}	Total 802.11a Receive Supply Current	LEN= Hi	-	15		mA
		LEN = Lo		0.2		
I _{CC-BT}	Total BT Supply Current	CBT = Hi	-	0.2		mA
I _{CC-OFF}	Total Supply Current	No RF, PEN2=PEN5=LEN2=LEN5=0V	-	10		μA

DATA SHEET
SE5501L: Dual Band 802.11n WLAN/BT Front End

Operating Modes

Mode#	Mode Description	PEN2	LEN2	PEN5	LEN5	CRX	CBT	CREF
0	All Off	0	0	0	0	0	0	X
1	BT	0	0	0	0	0	1	1
2	BT + RX5 Low Gain	0	0	0	0	1	1	1
3	BT + RX5 High Gain	0	0	0	1	1	1	1
4	BT + TX5	0	0	1	0	0	1	1
5	RX2 Low Gain + RX5 Low Gain	0	0	0	0	1	0	1
6	RX2 High Gain + RX5 Low Gain	0	1	0	0	1	0	1
7	RX2 Low Gain + RX5 High Gain	0	0	0	1	1	0	1
8	TX2	1	0	0	0	0	0	1
9	TX5	0	0	1	0	0	0	1
10	RX2 High Gain + RX5 High Gain	0	1	0	1	1	0	1

DATA SHEET
SE5501L: Dual Band 802.11n WLAN/BT Front End

AC Electrical Characteristics

2.4 GHz Transmit Characteristics

Conditions: $V_{CC} = 3.3\text{ V}$, PEN2= CREF=Hi, $T_A = 25\text{ }^\circ\text{C}$, as measured on Skyworks Solutions' SE5501L-EK1 evaluation board (de-embedded to device), all unused ports terminated with 50 ohms, unless otherwise noted.

Symbol	Parameter	Condition	Min.	Typ.	Max.	Unit
F_{IN}	Frequency Range	-	2400	-	2485	MHz
EVM	EVM	Pout = 19.5 dBm Pout = 18 dBm		2.5 2.0	3.5 2.5	%
S_{21}	Gain	2400 – 2485 MHz	19	22	25	dB
S_{21_OOB}	Out of Band Gain	1600 – 1660 MHz 3200 – 3215 MHz			-10 -10	dBc
ΔS_{21}	Gain Variation	Over 2400-2485 MHz Band		1.5	2	dBpp
S_{11}	Input Return Loss			-14	-10	dB
S_{22}	Output Return Loss			-10	-6	dB
P_N	Wideband Noise	800 – 2170 MHz		-140		dBm/Hz
NF	Noise Figure				10	dB
2f	11b Harmonics	2f @ Pout= 22 dBm		-25	-20	dBm/MHz
3f		3f @ Pout = 22 dBm		-35	-30	
ACP11b	Spectral Mask	11b @ Pout=22 dBm: fc +/- 11 MHz fc +/- 22 MHz		-34 -54	-32 -52	dBc
ACP11g		11g @ Pout=20 dBm: fc +/- 11 MHz fc +/- 20 MHz fc +/- 30 MHz		-23 -30 -43	-20 -28 -40	dBc
ACP11n		11n @ Pout=18 dBm: fc +/- 11 MHz fc +/- 20 MHz fc +/- 30 MHz		-23 -30 -48	-20 -28 -45	dBc
STAB	Stability	$P_{OUT} \leq 20\text{ dBm}$ Load VSWR = 10:1	All non-harmonically related outputs less than -45 dBm/MHz			

DATA SHEET
SE5501L: Dual Band 802.11n WLAN/BT Front End

2.4 GHz Receive Characteristics

Conditions: VCC = 3.3V, LEN2=CRX=CREF = Hi, TA = 25 °C, as measured on Skyworks Solutions' SE5501L-EK1 evaluation board (de-embedded to device), all unused ports terminated with 50 ohms, unless otherwise noted.

Symbol	Parameter	Condition	Min.	Typ.	Max.	Unit
F _{OUT}	Frequency Range	-	2400	-	2485	MHz
S ₂₁	Gain	LEN2 = Hi	13	15	17	dB
		LEN2 = Lo		-8		
S _{21_OOB}	Out of Band Gain	800 – 1990 MHz		7		dB
ΔS ₂₁	Gain Variation	2400 – 2485 MHz, Over any 20MHz band	-	0.25	0.4	dB
NF	Noise Figure	LEN2 = Hi	-	2.0	2.5	dB
IIP3	Input Third Order Intercept	LEN2 = Hi	0	2	-	dBm
ISOL _{RRX}	Reverse Isolation		-25	-	-	dB
INT	Interferer	1710-1990, max gain change 0.5 dB	-10	-8	-	dBm
S ₁₁	Input Return Loss	-	-	-12	-10	dB
IP1dB	Input P1dB	LEN2 = Hi	-8	-7	-	dBm
		LEN2 = Lo	+5	+10	-	
T _{EN}	Enable Time	10% to 90% of RX RF power, from time that LEN2 is at 50%	-	-	800	nsec

DATA SHEET
SE5501L: Dual Band 802.11n WLAN/BT Front End

5 GHz Transmit Characteristics

Conditions: VCC = 3.3 V, PEN5=CREF= Hi, TA = 25 °C, as measured on Skyworks Solutions' SE5501L-EK1 evaluation board (de-embedded to device), all unused ports terminated with 50 ohms, unless otherwise noted.

Symbol	Parameter	Condition	Min.	Typ.	Max.	Unit
F _{IN}	Frequency Range	-	5150	-	5850	MHz
EVM	EVM	Pout = 18 dBm Pout = 17 dBm		2.5 2.0	3.5 2.5	%
S ₂₁	Gain		15	18	21	dB
S _{21_OOB}	Out of Band Gain	3265 – 3900 MHz 6900 – 7250 MHz 7250 – 7800 MHz			-15 -8 -15	dBc
ΔS ₂₁	Gain Variation	Over 5150-5850 MHz Band		2.0	3.0	dBpp
S ₁₁	Input Return Loss			-10	-8	dB
S ₂₂	Output Return Loss			-10	-6	dB
P _N	Wideband Noise	800 – 2170 MHz		-150		dBm/Hz
NF	Noise Figure				10	dB
2f	Harmonics	2f @ Pout= 18 dBm		-40	-35	dBm/MHz
3f		3f @ Pout = 18 dBm		-50	-45	
ACP11a	Spectral Mask	11a @ Pout=18 dBm: fc +/- 11 MHz fc +/- 20 MHz fc +/- 30 MHz		-23 -30 -43	-20 -28 -40	dBc
ACP11n		11n @ Pout=16 dBm: fc +/- 11 MHz fc +/- 20 MHz fc +/- 30 MHz		-23 -30 -48	-20 -28 -45	dBc
	Stability	P _{OUT} ≤ 18dBm Load VSWR = 10:1	All non-harmonically related outputs less than -45 dBm/MHz			

DATA SHEET
SE5501L: Dual Band 802.11n WLAN/BT Front End

5 GHz Receive Characteristics

Conditions: V_{CC} = 3.3 V, LEN5=CREF=CRX= Hi, T_A = 25 °C, as measured on Skyworks Solutions' SE5501L-EK1 evaluation board (de-embedded to device), all unused ports terminated with 50 ohms, unless otherwise noted.

Symbol	Parameter	Condition	Min.	Typ.	Max.	Unit
F _{OUT}	Frequency Range	-	5150	-	5850	MHz
S ₂₁	Gain	LEN5 = Hi	8	11	14	dB
		LEN5 = Lo	-19	-14	-9	dB
S _{21_OOB}	Out of Band Gain	800 – 1990 MHz	-	-	-10	dB
ΔS ₂₁	Gain Variation	5150 – 5850 MHz, Over any 40MHz band	-	0.25	0.4	dB
NF	Noise Figure	LEN5=Hi	-	2.5	3	dB
IIP3	Input Third Order Intercept	LEN5= Hi	3	5	-	dBm
ISOL _{RRX}	Reverse Isolation		20	-	-	dB
INT	Interferer	1710 - 2500 MHz, max gain change = 0.5 dB	-10	-	-	dBm
S ₁₁	Input Return Loss	-	-	-6		dB
IP1dB	Input P1dB	LEN5 = Hi	-7	-5	-	dBm
		LEN5 = Lo	+5	+10	-	
T _{EN}	Enable Time	10% to 90% of RX RF power, from time that LEN5 is at 50%	-	-	800	nsec

Bluetooth Characteristics

Conditions: V_{CC} = 3.3 V, CBT=CREF= Hi, T_A = 25 °C, as measured on Skyworks Solutions' SE5501L-EK1 evaluation board (de-embedded to device), all unused ports terminated with 50 ohms, unless otherwise noted.

Symbol	Parameter	Condition	Min.	Typ.	Max.	Unit
F _{OUT}	Frequency Range	-	2400	-	2485	MHz
BT _{IL}	Insertion Loss	ANT2 to BTALL (CBT= Hi)	-	1.0	2.0	dB
		BTALL to BTRX (LEN2=Hi)		0.8		
S ₁₁	BT Port Return Loss	CBT= Hi	-	-14	-10	dB
ISOL _{SW}	Switch Isolation	CBT= Hi	20	-	-	dB
T _{EN}	Enable Time	10% to 90% of BT RF power, from time that CBT is at 50%	-	-	800	nsec

DATA SHEET
SE5501L: Dual Band 802.11n WLAN/BT Front End
Power Detector Characteristics

Conditions: $V_{CC} = 3.3\text{ V}$, $T_A = 25\text{ }^\circ\text{C}$, as measured on Skyworks Solutions' SE5501L-EK1 evaluation board (de-embedded to device), all unused ports terminated with 50 ohms, unless otherwise noted.

Symbol	Parameter	Condition	Min.	Typ.	Max.	Unit
F_{OUT}	Frequency Range	PEN2= Hi PEN5 = Hi	2400 5150	-	2500 5850	MHz
PDR	Power detect range, peak power	Measured at ANT	0	-	22	dBm
PDZ _{LOAD}	DC load impedance	-	-	2.5		k Ω
PDV _{P20}	Output Voltage, $P_{OUT} = 20\text{ dBm}$	-	-	0.8	1.3	V
PDV _{pnoRF}	Output Voltage, $P_{OUT} = \text{No RF}$	-	-	0.130	-	V
PD _{VAR}	Power Detector Accuracy	$P_{out} > 10\text{ dBm}$	-1.5		+1.5	dB
PD _{BW}	Power Detector Output Bandwidth			350		KHz

DATA SHEET
SE5501L: Dual Band 802.11n WLAN/BT Front End

Package Diagram

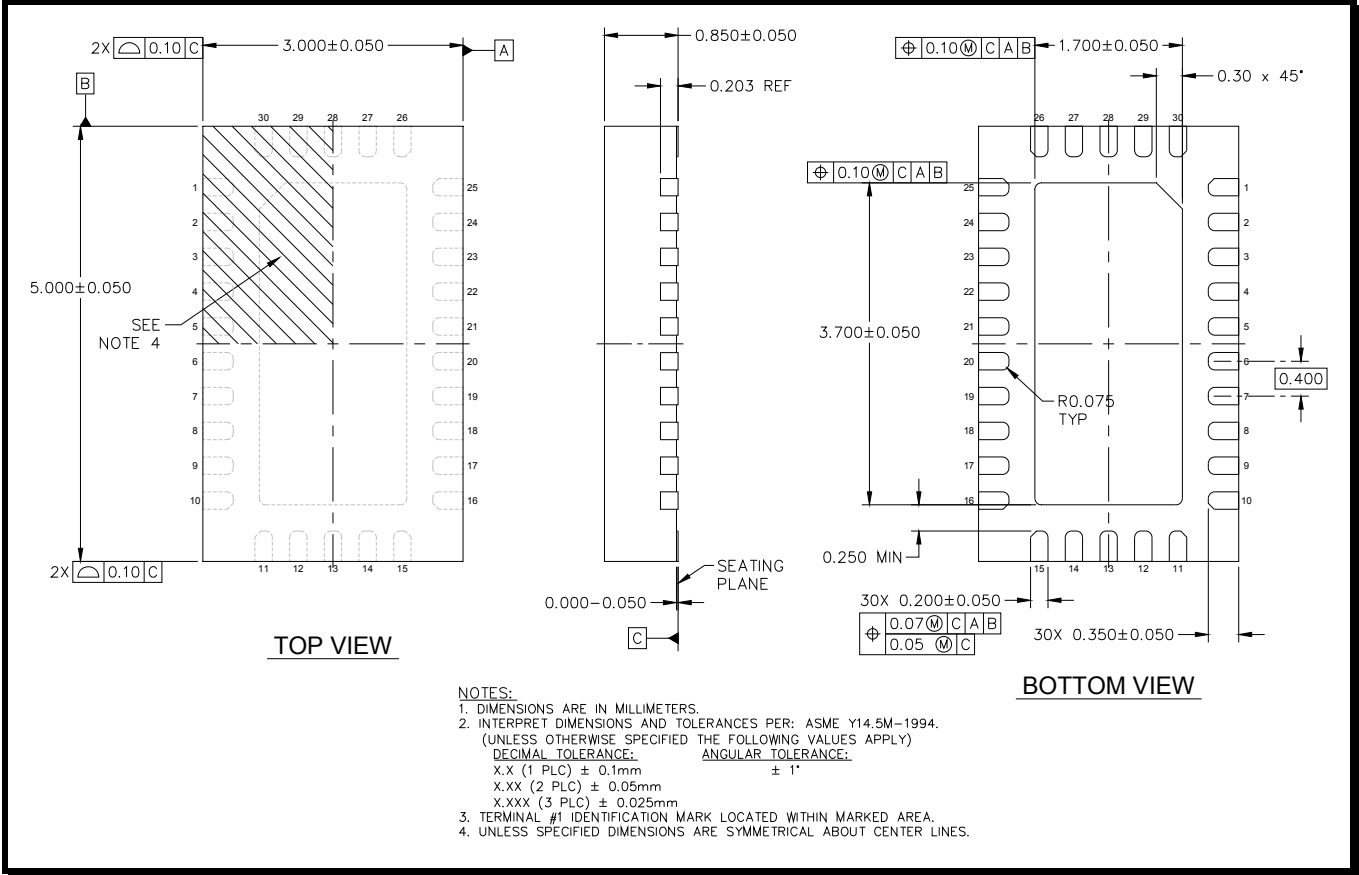

Figure 4: Package Outline Drawing

DATA SHEET
SE5501L: Dual Band 802.11n WLAN/BT Front End

Recommended PCB Footprint

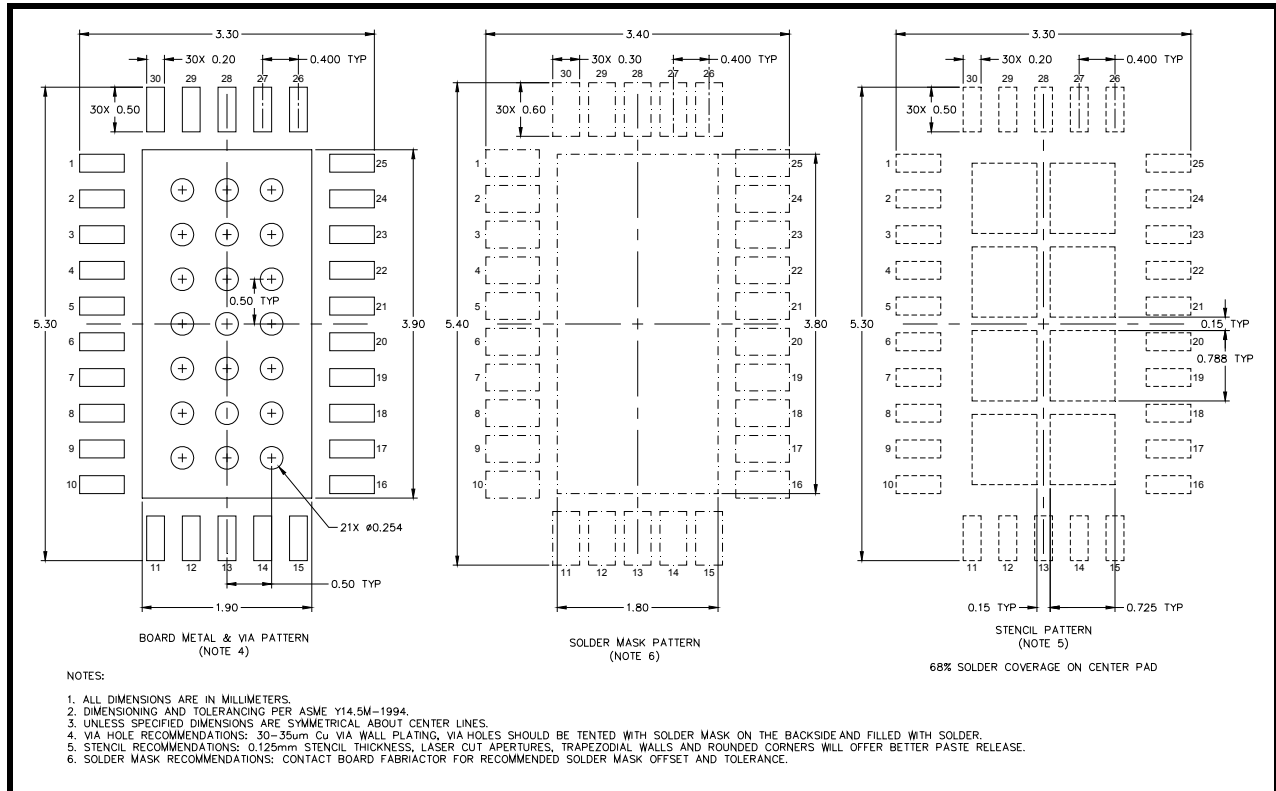

Figure 5: Recommended PCB footprint

Package Handling Information

Because of its sensitivity to moisture absorption, instructions on the shipping container label must be followed regarding exposure to moisture after the container seal is broken, otherwise, problems related to moisture absorption may occur when the part is subjected to high temperature during solder assembly. The SE5501L is capable of withstanding a Pb free solder reflow. Care must be taken when attaching this product, whether it is done manually or in a production solder reflow environment. If the part is manually attached, precaution should be taken to insure that the device is not subjected to temperatures above its rated peak temperature for an extended period of time. For details on both attachment techniques, precautions, and handling procedures recommended, please refer to:

- “Quad Flat No-Lead Module Solder Reflow & Rework Information”, *Document Number QAD-00045*.
- “Handling, Packing, Shipping and Use of Moisture Sensitive QFN”, *Document Number QAD-00044*.

DATA SHEET
SE5501L: Dual Band 802.11n WLAN/BT Front End

Branding Information

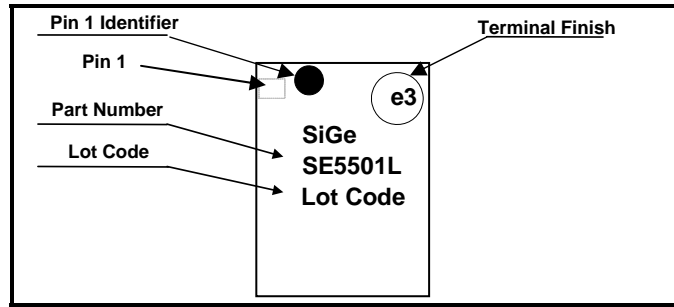

Figure 6: SE5501L Branding Information

Document Change History

Revision	Date	Notes
1.0	06/17/09	Created
1.1	07/14/2009	Updated pin-out
1.2	12/11/2009	Updated Package Outline and specifications
1.3	January-14-2011	Updated specifications
1.4	February-24-2011	Updated specifications
1.5	April-12-2011	Updated specifications
1.6	June-08-2011	Updated specifications
1.7	July-07-2011	Updated MSL rating
1.8	August-21-2011	Updated specifications
1.9	April-11-2012	Updated with Skyworks logo and disclaimer statement



SKYWORKS®

DATA SHEET SE5501L: Dual Band 802.11n WLAN/BT Front End

Copyright © 2012 Skyworks Solutions, Inc. All Rights Reserved.

Information in this document is provided in connection with Skyworks Solutions, Inc. ("Skyworks") products or services. These materials, including the information contained herein, are provided by Skyworks as a service to its customers and may be used for informational purposes only by the customer. Skyworks assumes no responsibility for errors or omissions in these materials or the information contained herein. Skyworks may change its documentation, products, services, specifications or product descriptions at any time, without notice. Skyworks makes no commitment to update the materials or information and shall have no responsibility whatsoever for conflicts, incompatibilities, or other difficulties arising from any future changes.

No license, whether express, implied, by estoppel or otherwise, is granted to any intellectual property rights by this document. Skyworks assumes no liability for any materials, products or information provided hereunder, including the sale, distribution, reproduction or use of Skyworks products, information or materials, except as may be provided in Skyworks Terms and Conditions of Sale.

THE MATERIALS, PRODUCTS AND INFORMATION ARE PROVIDED "AS IS" WITHOUT WARRANTY OF ANY KIND, WHETHER EXPRESS, IMPLIED, STATUTORY, OR OTHERWISE, INCLUDING FITNESS FOR A PARTICULAR PURPOSE OR USE, MERCHANTABILITY, PERFORMANCE, QUALITY OR NON-INFRINGEMENT OF ANY INTELLECTUAL PROPERTY RIGHT; ALL SUCH WARRANTIES ARE HEREBY EXPRESSLY DISCLAIMED. SKYWORKS DOES NOT WARRANT THE ACCURACY OR COMPLETENESS OF THE INFORMATION, TEXT, GRAPHICS OR OTHER ITEMS CONTAINED WITHIN THESE MATERIALS. SKYWORKS SHALL NOT BE LIABLE FOR ANY DAMAGES, INCLUDING BUT NOT LIMITED TO ANY SPECIAL, INDIRECT, INCIDENTAL, STATUTORY, OR CONSEQUENTIAL DAMAGES, INCLUDING WITHOUT LIMITATION, LOST REVENUES OR LOST PROFITS THAT MAY RESULT FROM THE USE OF THE MATERIALS OR INFORMATION, WHETHER OR NOT THE RECIPIENT OF MATERIALS HAS BEEN ADVISED OF THE POSSIBILITY OF SUCH DAMAGE.

Skyworks products are not intended for use in medical, lifesaving or life-sustaining applications, or other equipment in which the failure of the Skyworks products could lead to personal injury, death, physical or environmental damage. Skyworks customers using or selling Skyworks products for use in such applications do so at their own risk and agree to fully indemnify Skyworks for any damages resulting from such improper use or sale.

Customers are responsible for their products and applications using Skyworks products, which may deviate from published specifications as a result of design defects, errors, or operation of products outside of published parameters or design specifications. Customers should include design and operating safeguards to minimize these and other risks. Skyworks assumes no liability for applications assistance, customer product design, or damage to any equipment resulting from the use of Skyworks products outside of stated published specifications or parameters.

Skyworks, the Skyworks symbol, and "Breakthrough Simplicity" are trademarks or registered trademarks of Skyworks Solutions, Inc., in the United States and other countries. Third-party brands and names are for identification purposes only, and are the property of their respective owners. Additional information, including relevant terms and conditions, posted at www.skyworksinc.com, are incorporated by reference.