



**FEATURES:**

- Step Down DC/DC LED driver
- Constant current output
- Non-Isolated
- High efficiency up to 93%
- Operating Temperature range -40°C to +85°C
- PWM/Digital and Analog Voltage dimming
- Remote ON/OFF Control
- Built with MLCC capacitors only



**Models**  
Single output

Model	Input Voltage (V)	Output Voltage (V)	Output Current max (mA)	Max Capacitive Load (uF)	Efficiency (%)	Package Type
AMLDP-1630Z	7-16	2-14	300	47	93	DIP8
AMLDP-1635Z	7-16	2-14	350	47	93	DIP8
AMLDP-1650Z	7-16	2-14	500	47	93	DIP8
AMLDP-1660Z	7-16	2-14	600	47	93	DIP8
AMLDP-1670Z	7-16	2-14	700	47	93	DIP8
AMLDP-16100Z	7-16	2-14	1000	47	93	DIP8

NOTE: All specifications in this datasheet are measured at an ambient temperature of 25°C, humidity<75%, nominal input voltage and at rated output load unless otherwise specified.

**Input Specifications**

Parameters	Nominal	Typical	Maximum	Units
Voltage range	14	7-16		VDC
Filter	Capacitor			
Absolute Maximum Rating			20	VDC
Peak Input Voltage time			500	ms
DC/DC ON (Leave open if not used)	ON – Open or 0..2V<Vadj<0.3V;			
DC/DC OFF	OFF(shutdown) – Vadj <0.15			
Maximum Remote pin drive current	Vadj = 1.25V		1	mA
Quiescent Current in Shutdown mode	Vin = 16V, Vadj <0.25		25	uA
On/Off Control (Digital Control)	Max PWM Frequency 1KHz			
Drive with DC Voltage	0.3V < VADJ<1.25V to adjust output current from 1% to 100%			

**Output Specifications**

Parameters	Conditions	Typical	Maximum	Units
Current accuracy		±5		%
Output Voltage range	V input = 16	2-14		VDC
Output current	Vin – Vout >1.5V to 3V	See model table above		
Short Circuit protection	Regulated at the rated current for each model			
Output no load Protection	Continuous			
Max load capacitance			47	uF
Temperature coefficient	Ta = -40 to +85°C	±0.03		%/°C
Ripple & Noise	20MHz Bandwidth	120		mV p-p

**General Specifications**

Parameters	Conditions	Typical	Maximum	Units
Switching frequency	100% load	90-300		KHz
Operating temperature		-40 to +85		°C
Storage temperature		-40 to +125		°C
Maximum case temperature			105	°C
Thermal Impedance	Free air convection	+40		
Cooling	Free air convection			
Humidity				% RH
Case material	Non-Conductive Black Plastic (UL94-V0 rated)			

### General Specifications (continued)

Parameters	Conditions	Typical	Maximum	Units
Weight		1.8		g
Dimensions (L x W x H)		0.50 x 0.40 x 0.27 inches	12.70 x 10.16 x 6.85 mm	
MTBF		> 3,300,000 hrs (MIL-HDBK-217 F at +25 °C)		
Maximum soldering temperature	1.5mm from case for 10sec		260	°C

**NOTES:**

- 1.Reversed polarity at the input power will damage the driver. The input ground must not be connected to the negative output.
- 2.Leave the pin VADJ opened if not used , grounding VADJ will shut the driver off, connecting VADJ to +Vin will damage the driver.
- 3.Maximum output open voltage is equal to input voltage

### Safety Specifications

Parameters	
Agency Approvals	CE
Standards	EN55015: 2007+A2: 2009 EN61547: 2009 IEC 61000-4-2: 2008 IEC 61000-4-3: 2006+A1: 2007+A2: 2010 IEC 61000-4-4: 2004+A1: 2010 IEC 61000-4-5: 2005 IEC 61000-4-6: 2008 IEC 61000-4-8: 2009 IEC 61000-4-11: 2004 NOTE: also designed to meet EN609501

### Pin Out Specifications

Pin	Single	
1	+ V Input	+ DC Supply
4	+ V Output	LED Anode connection
5	- V Output	LED Cathode connection
7	Vadj	PWM/ON/OFF or not used
8	- V Input	- DC Supply

### Dimensions

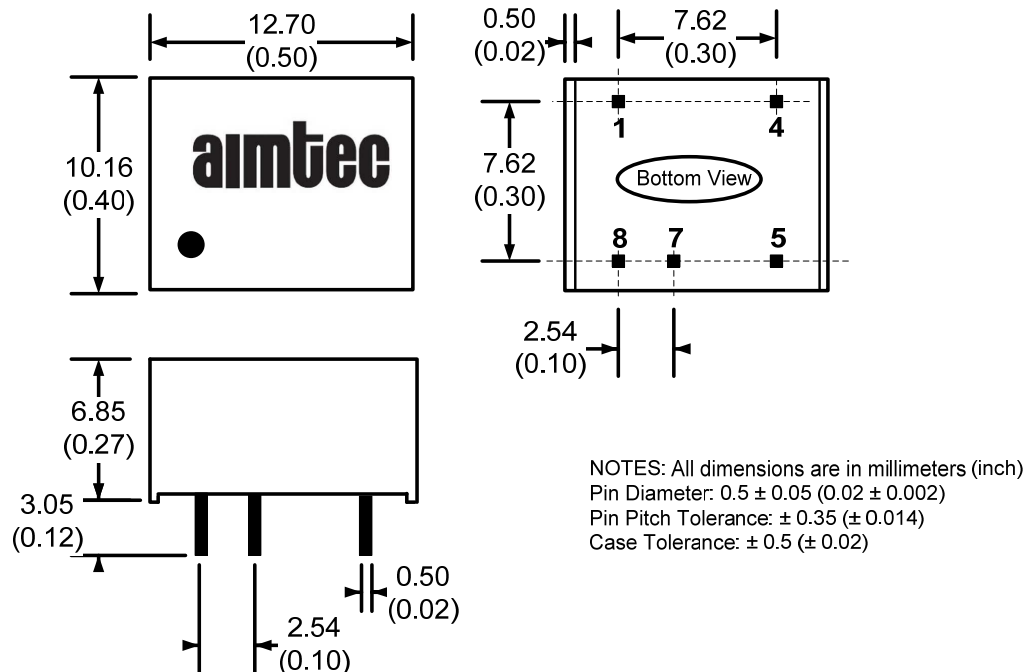

**Application circuit examples:**

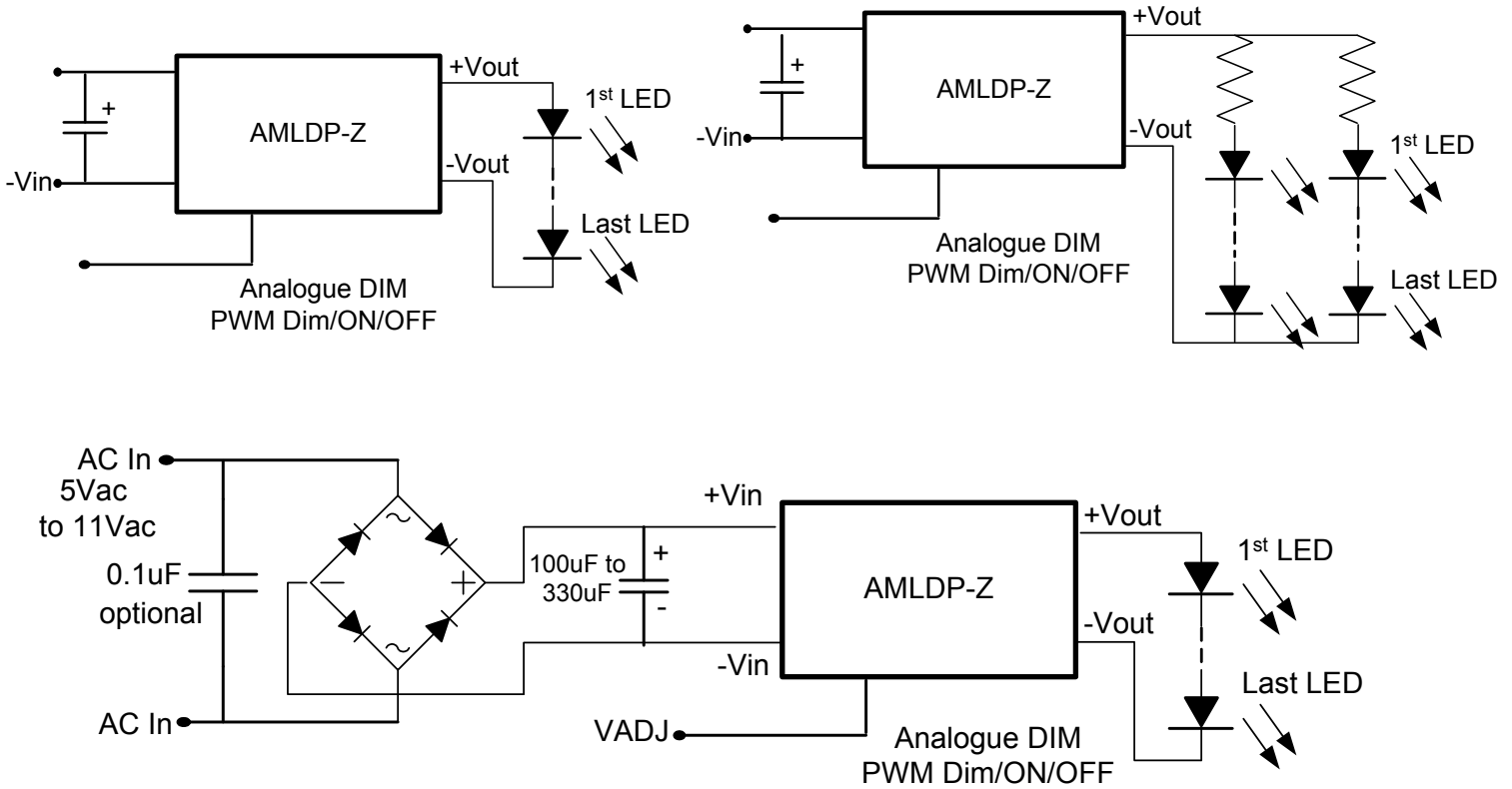

**Output Current Adjustment by External DC Control Voltage:**

The nominal output current is given by:

$$I_{outnom} = I_{out} \frac{V_{adj}}{1.25}$$

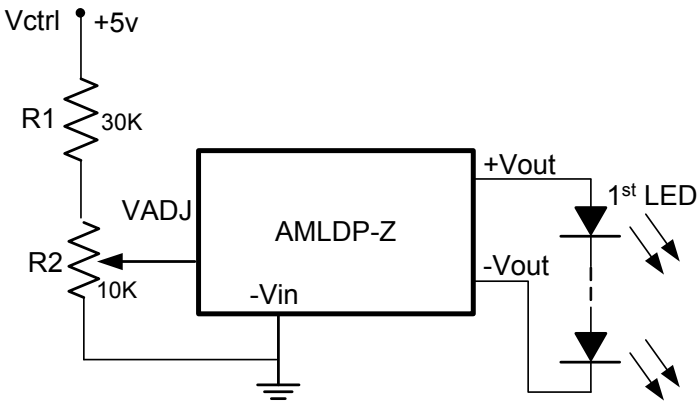
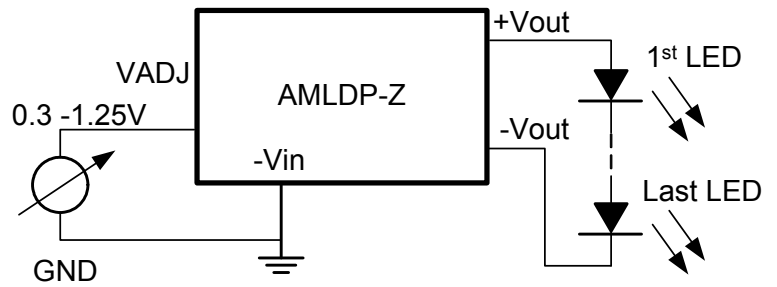

$$V_{ADJ} = \frac{R_2}{R_1 + R_2} \times V_{ctrl}$$

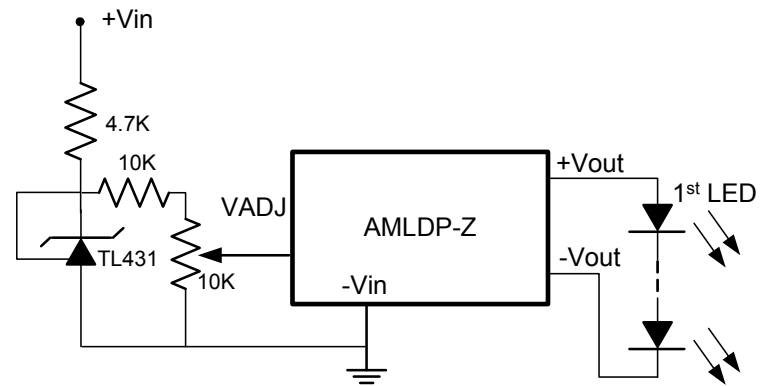

**Resistive Dimming Control**

A simplified dimming control can be achieved using a variable resistor connected between VADJ and GND. Capacitor CADJ is optional, it is installed to limit AC mains interference and high frequency noise. The recommended value of CADJ is 0.22µF.

The nominal output current is given by:

$$I_{outnom} = I_{out} \times \frac{R_{adj}}{R_{adj} + 200K}$$

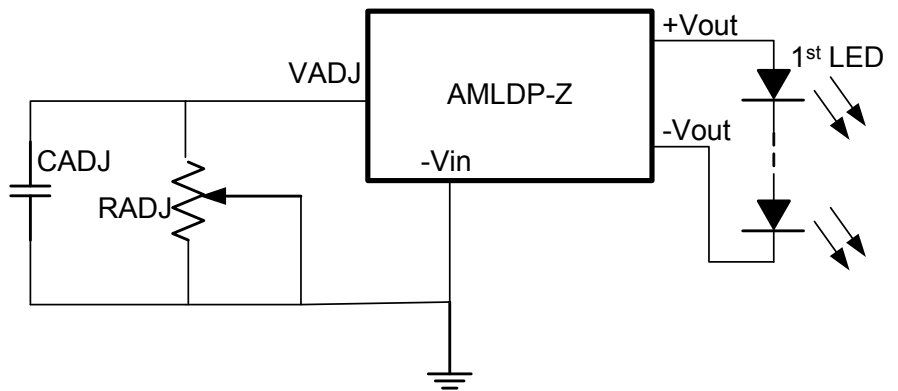

NOTE: Typical error is ±10% with resistive dimming control  
If the value of R<sub>adj</sub> is between 0 to 2MΩ, the maximum adjustment range will be 25% to 90%, (for Vin -Vout <10VDC)

## Output Current Adjustment by PWM Control: Driving VADJ Directly

A Pulse Width Modulated (PWM) signal with a duty cycle of DPWM can be applied directly to VADJ pin as shown below.

The output current is given by:

$$I_{outnom} = I_{out} \times DPWM \quad [\text{for } 0.01 < DPWM < 1]$$

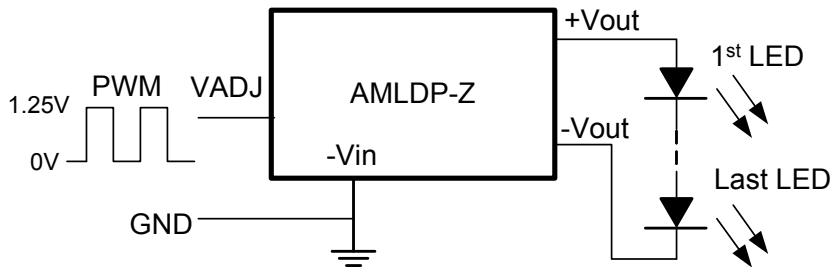

## Driving VADJ Via Open Collector Transistor

The VADJ can also be driven via an open collector transistor as shown below.

The diode and resistor serve to suppress any possible high amplitude negative voltage spikes to the VADJ input resulting from the collector to emitter capacitance of the transistor. Any negative voltage spikes will cause errors in output current and/or unstable driver operation.

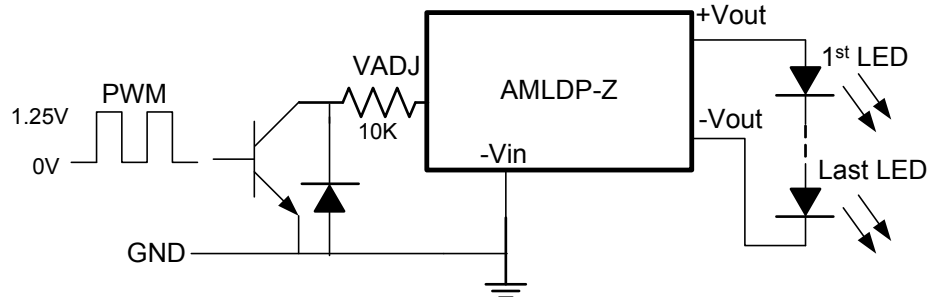

## Driving the VADJ from a Microcontroller

The VADJ can be driven from an open drain output of a microcontroller as shown below. The diode and resistor serve to suppress any possible high amplitude negative voltage spikes to the VADJ input resulting from the drain to source capacitance of the FET. Any negative voltage spikes will cause errors in output current and/or unstable driver operation.

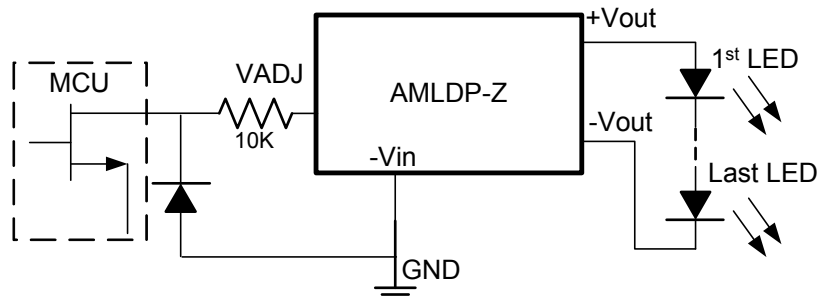

### Output Current Adjustment by PWM Control (Dimming):

A PWM signal must have a frequency of greater than 100Hz to prevent any visible flicker.

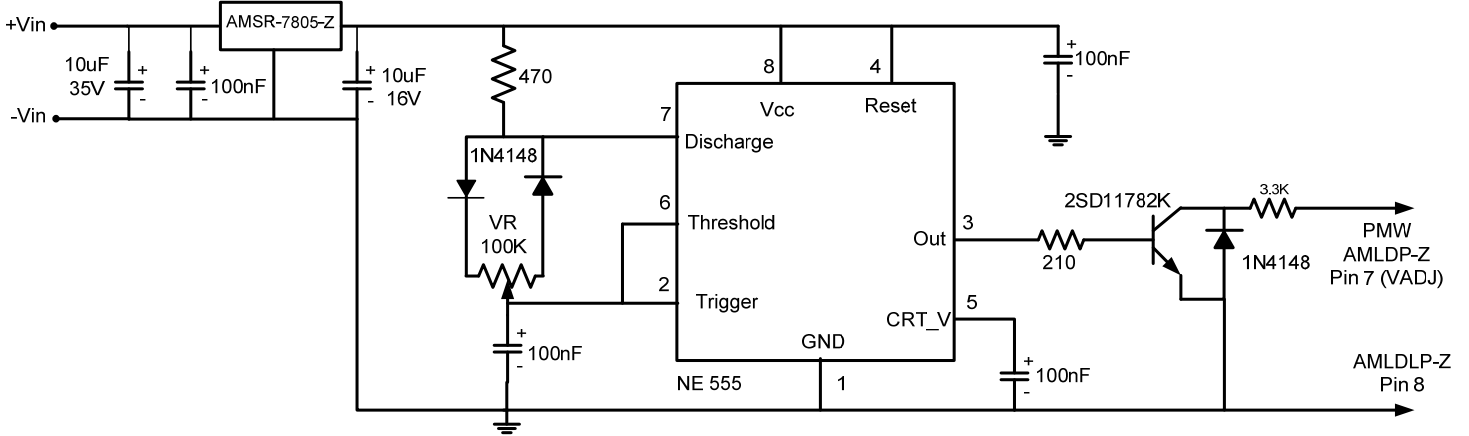

### Output Current Adjustment by PWM Control (Flash):

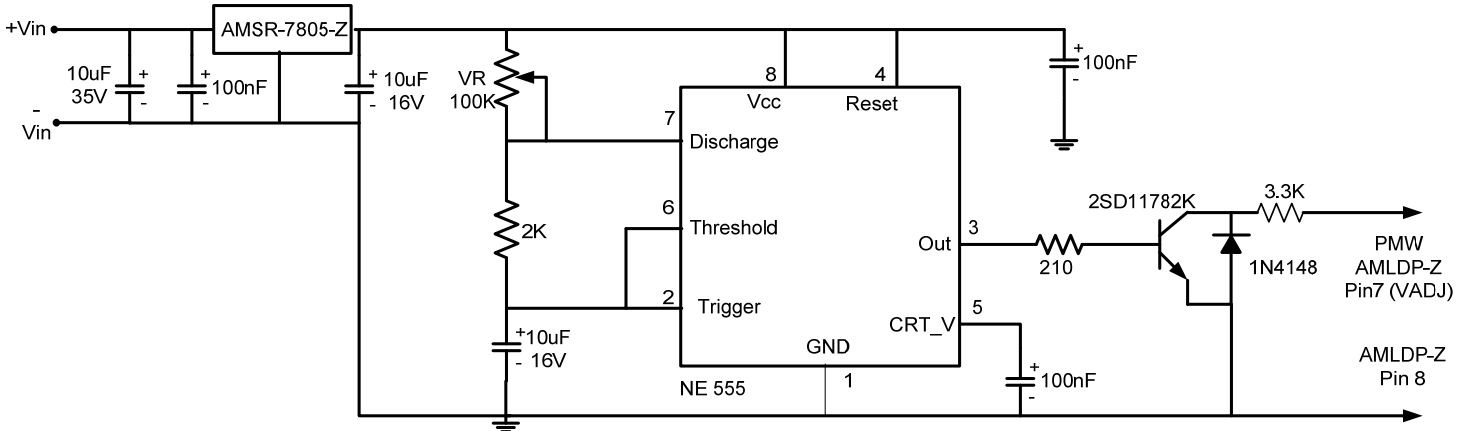

### Radiated & Conducted Emissions

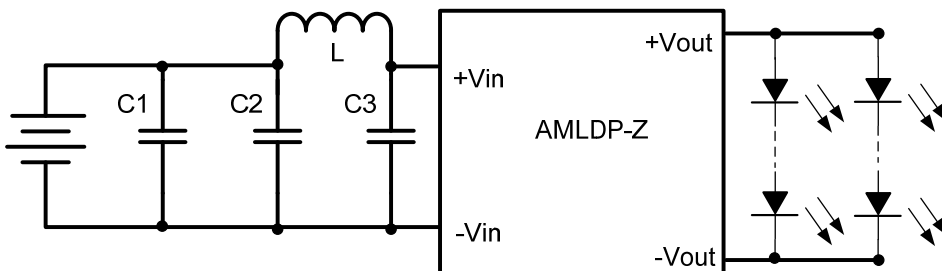

C1	C2	L	C3
10uF/35V	10uF/35V	47 uH	47 uF/100V

**Typical Characteristics: AMLDP-1630Z**

Operating Frequency vs Input Voltage  
(Forward Voltage = 3.5V per LED)

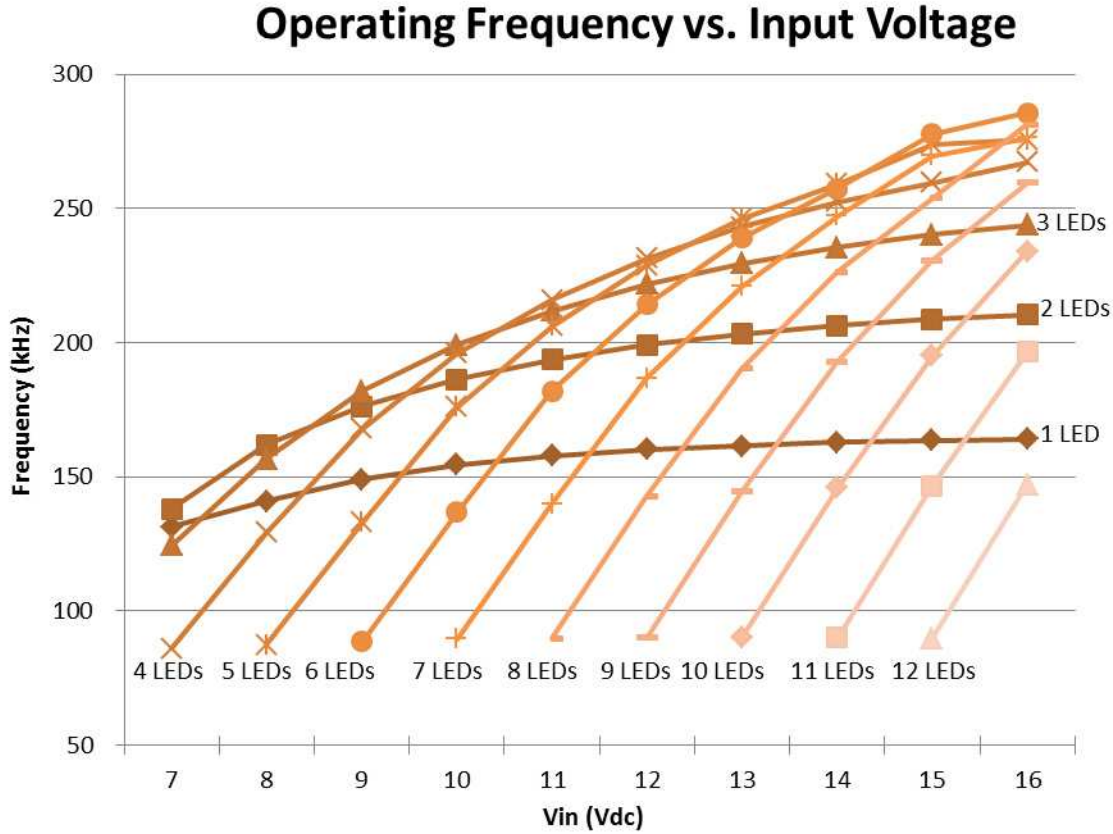

Efficiency vs Vin  
(Forward Voltage = 3.5V per LED)

### Efficiency vs. Input Voltage

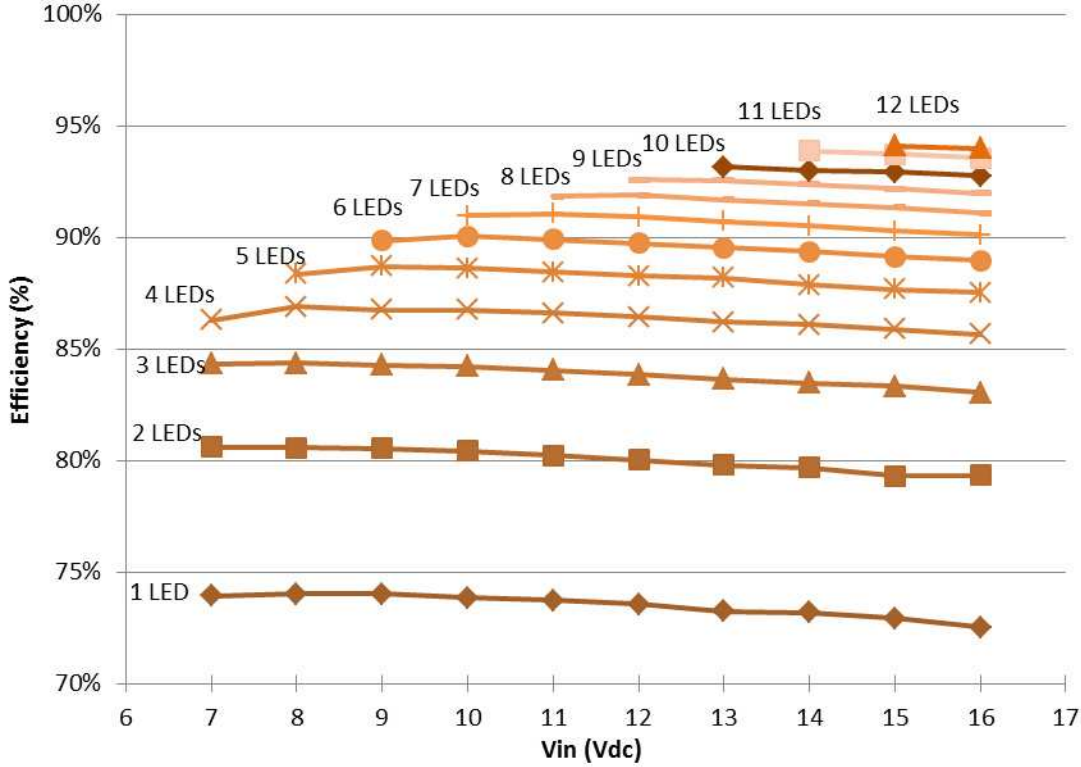

Output Current Vs VADJ

### Output Current vs. VADJ

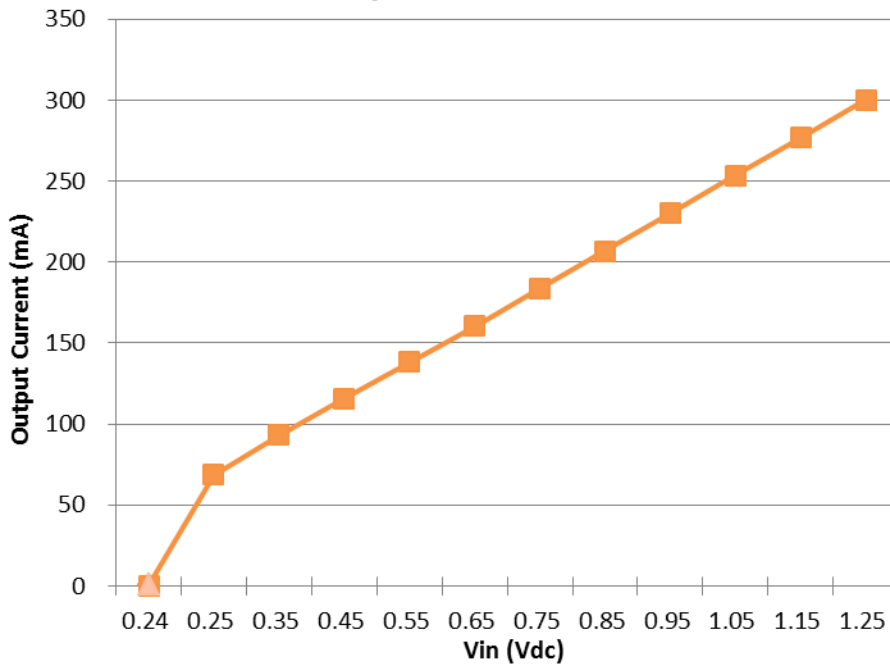



**Typical Characteristics: AMLDP-1635Z**

Operating Frequency vs Input Voltage  
(Forward Voltage = 3.5V per LED)

**Operating Frequency vs. Input Voltage**

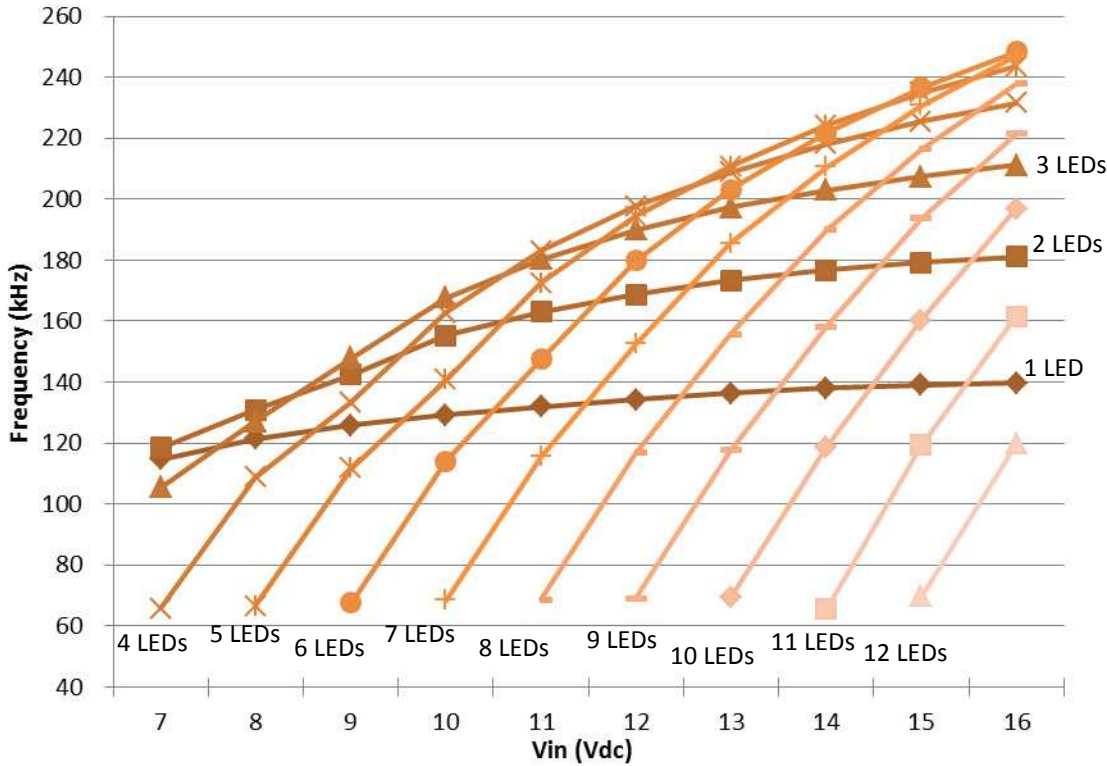

Efficiency vs Vin  
(Forward Voltage = 3.5V per LED)

### Efficiency vs. Input Voltage

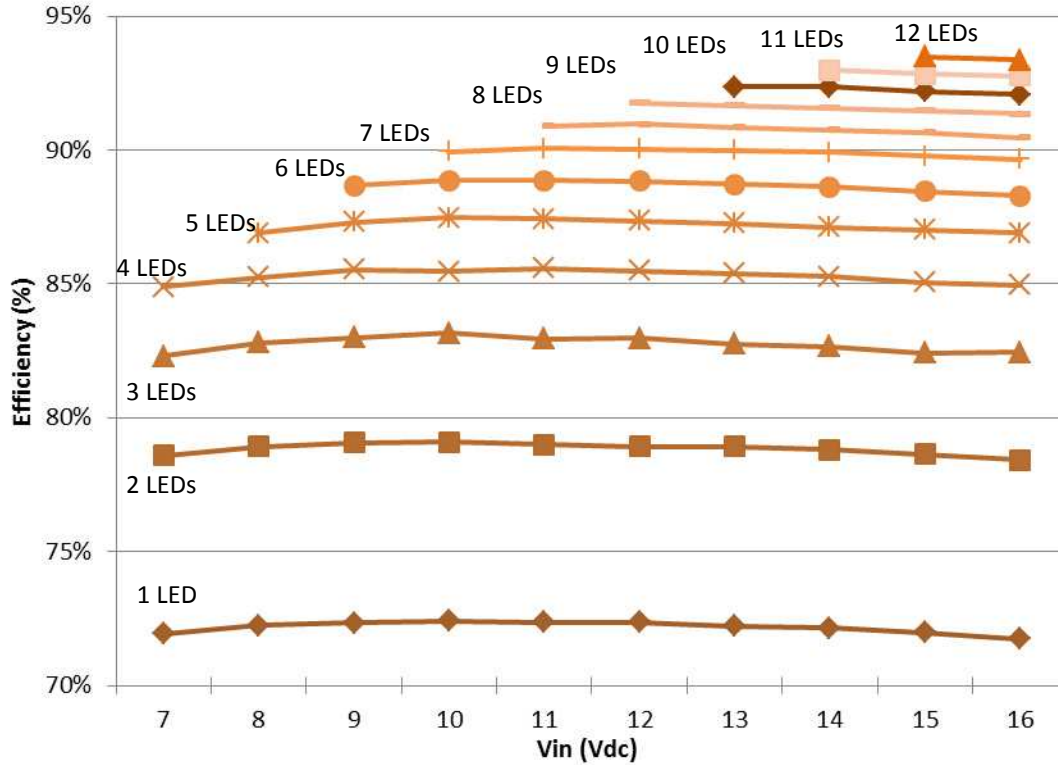

Output Current Vs VADJ

### Output Current vs. VADJ

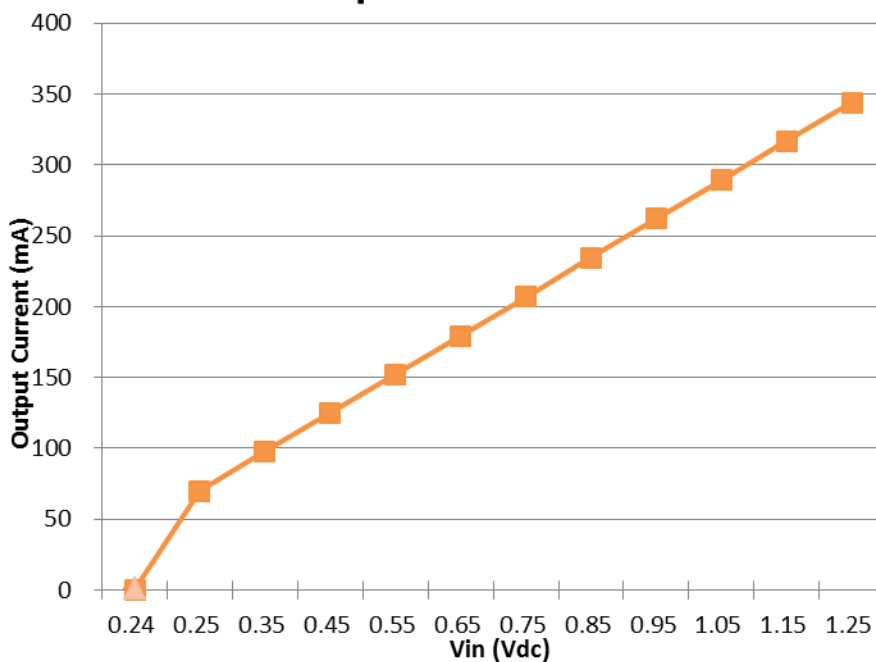

**Typical Characteristics: AMLDP-1650Z**

Operating Frequency vs Input Voltage  
(Forward Voltage = 3.5V per LED)

**Operating Frequency vs. Input Voltage**

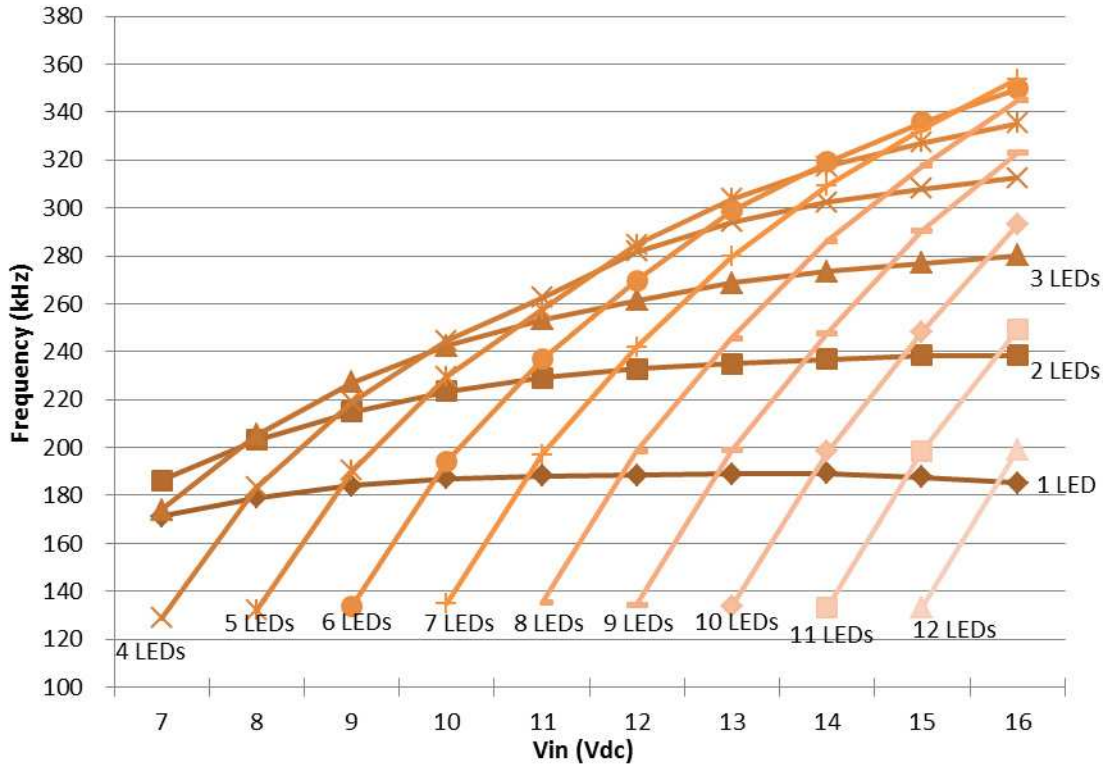

Efficiency vs Vin  
(Forward Voltage = 3.5V per LED)

### Efficiency vs. Input Voltage

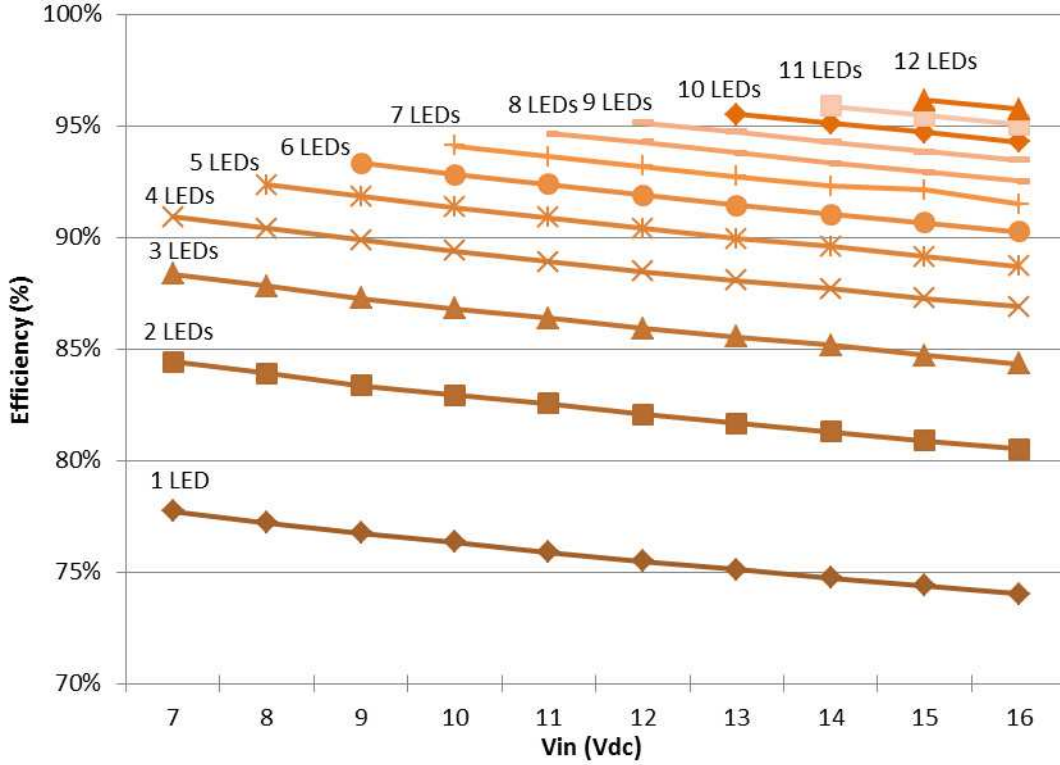

Output Current Vs VADJ

### Output Current vs. VADJ

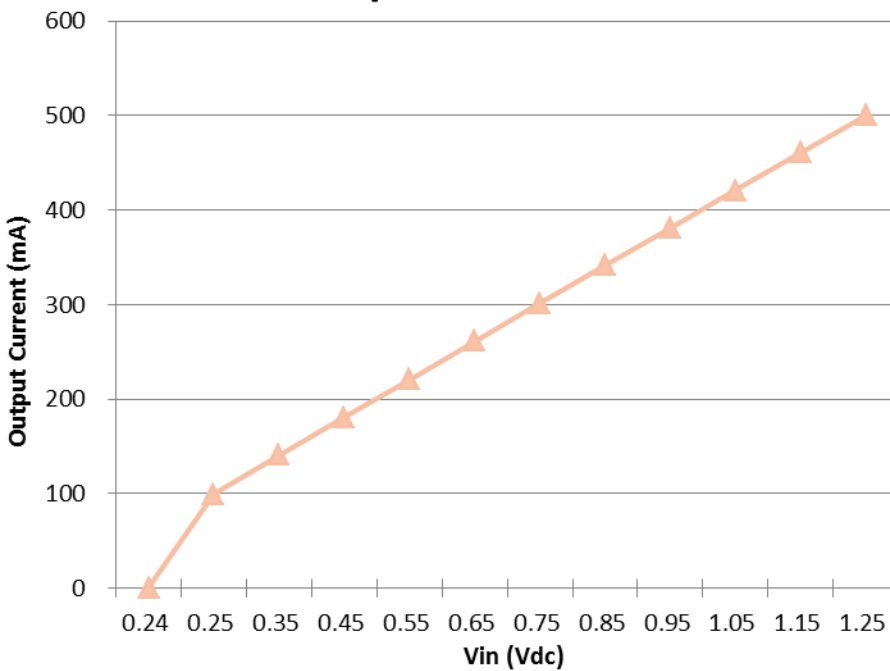

**Typical Characteristics: AMLDP-1660Z**

Operating Frequency vs Input Voltage  
(Forward Voltage = 3.5V per LED)

**Operating Frequency vs. Input Voltage**

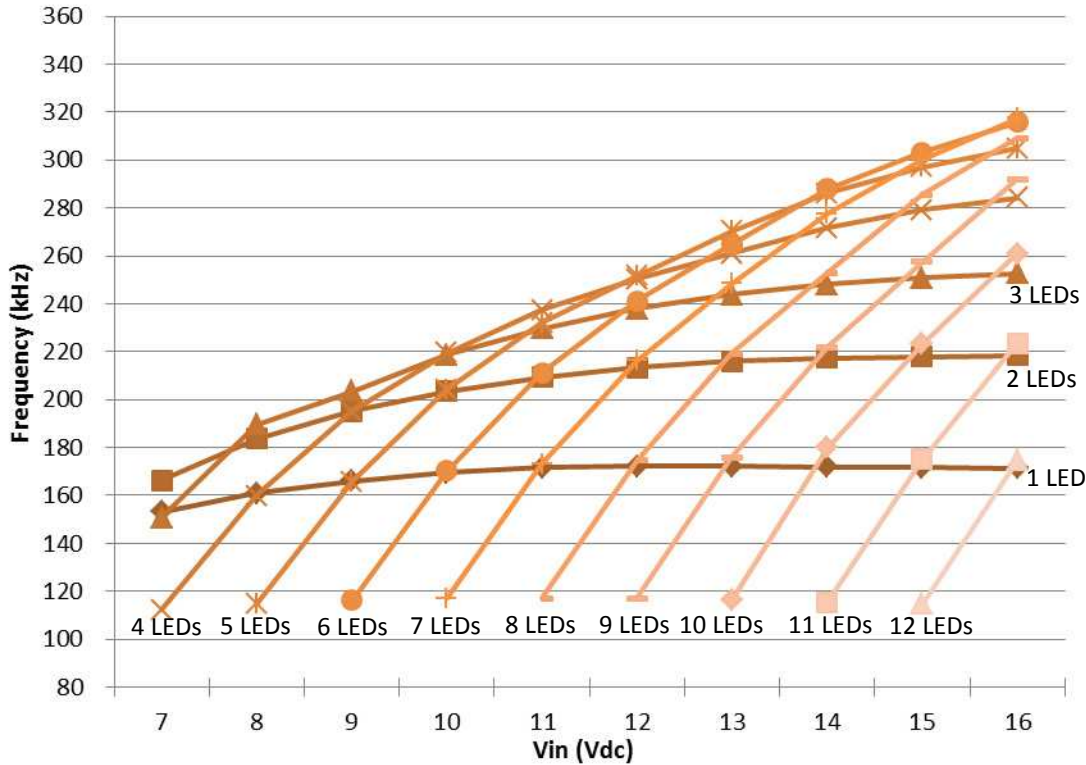

Efficiency vs Vin  
(Forward Voltage = 3.5V per LED)

### Efficiency vs. Input Voltage

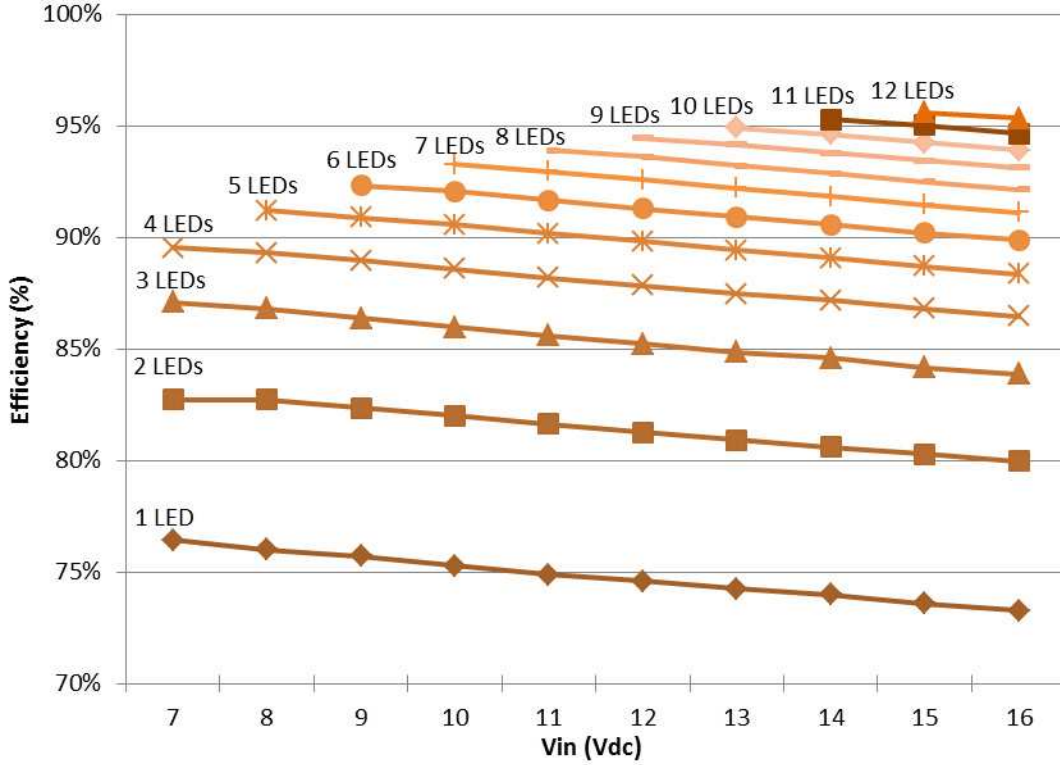

Output Current Vs VADJ

### Output Current vs. VADJ

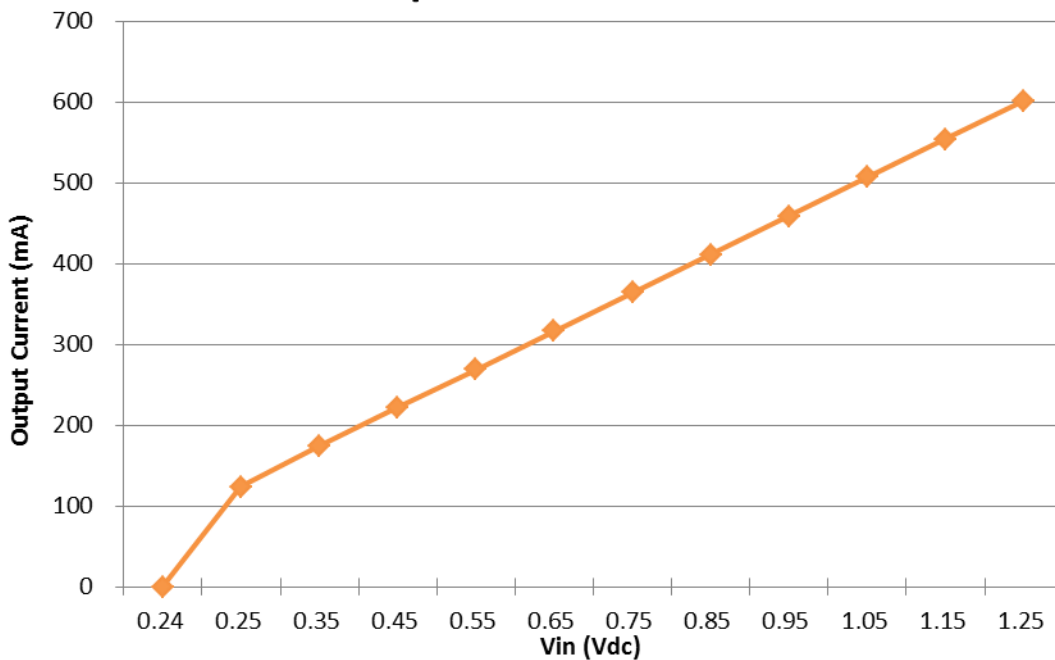

**Typical Characteristics: AMLDP-1670Z**

Operating Frequency vs Input Voltage  
(Forward Voltage = 3.5V per LED)

**Operating Frequency vs. Input Voltage**

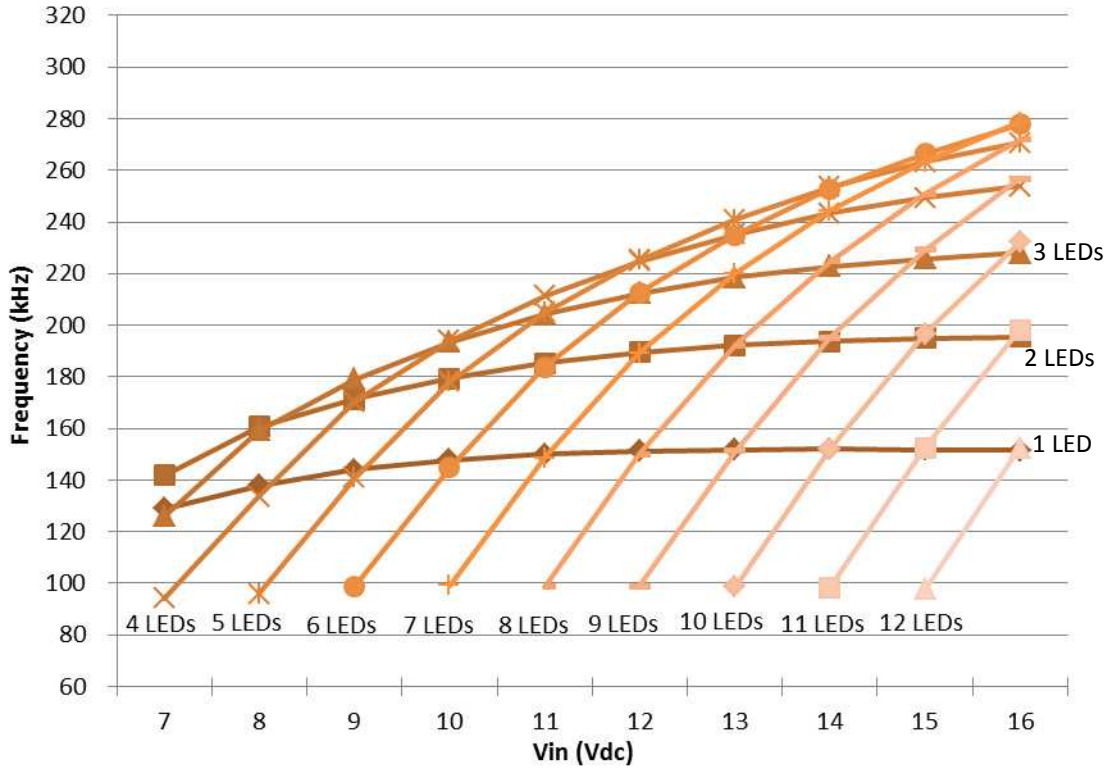

Efficiency vs Vin  
(Forward Voltage = 3.5V per LED)

### Efficiency vs. Input Voltage

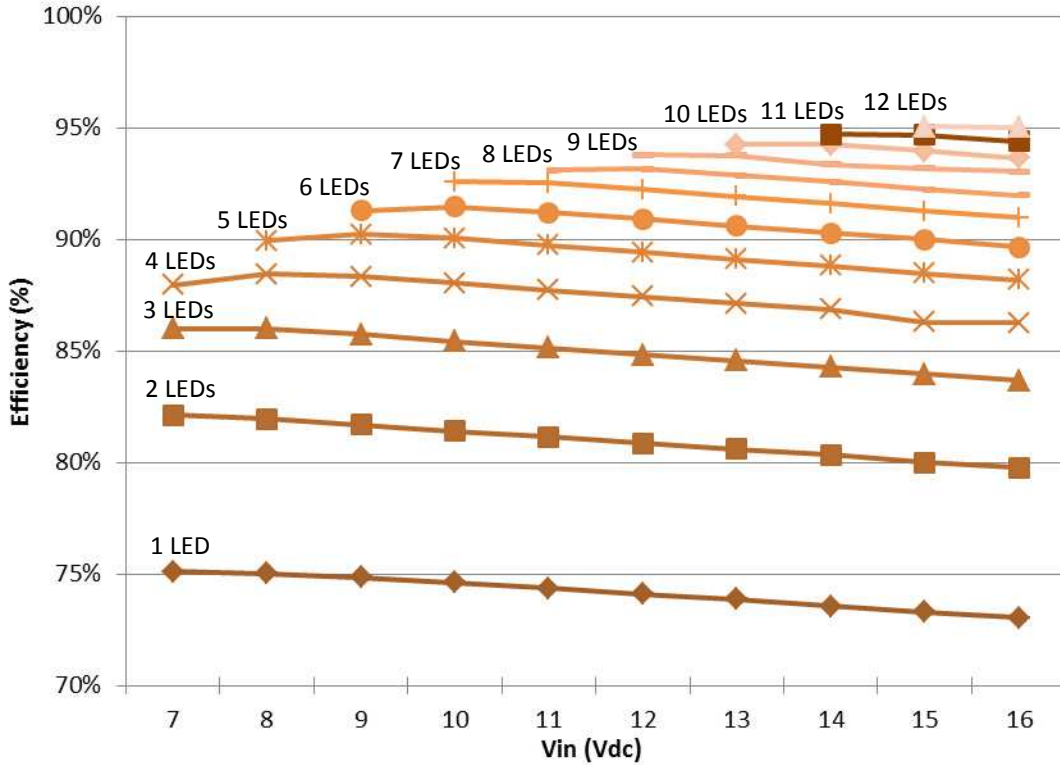

Output Current Vs VADJ

### Output Current vs. VADJ

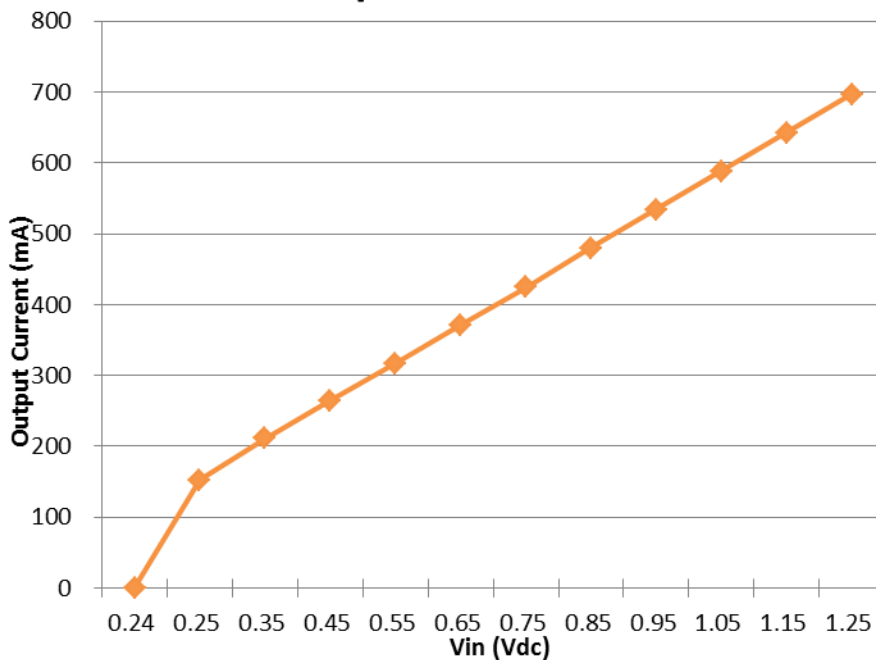



**Typical Characteristics: AMLDP-16100Z**

Operating Frequency vs Input Voltage  
(Forward Voltage = 3.5V per LED)

**Operating Frequency vs. Input Voltage**

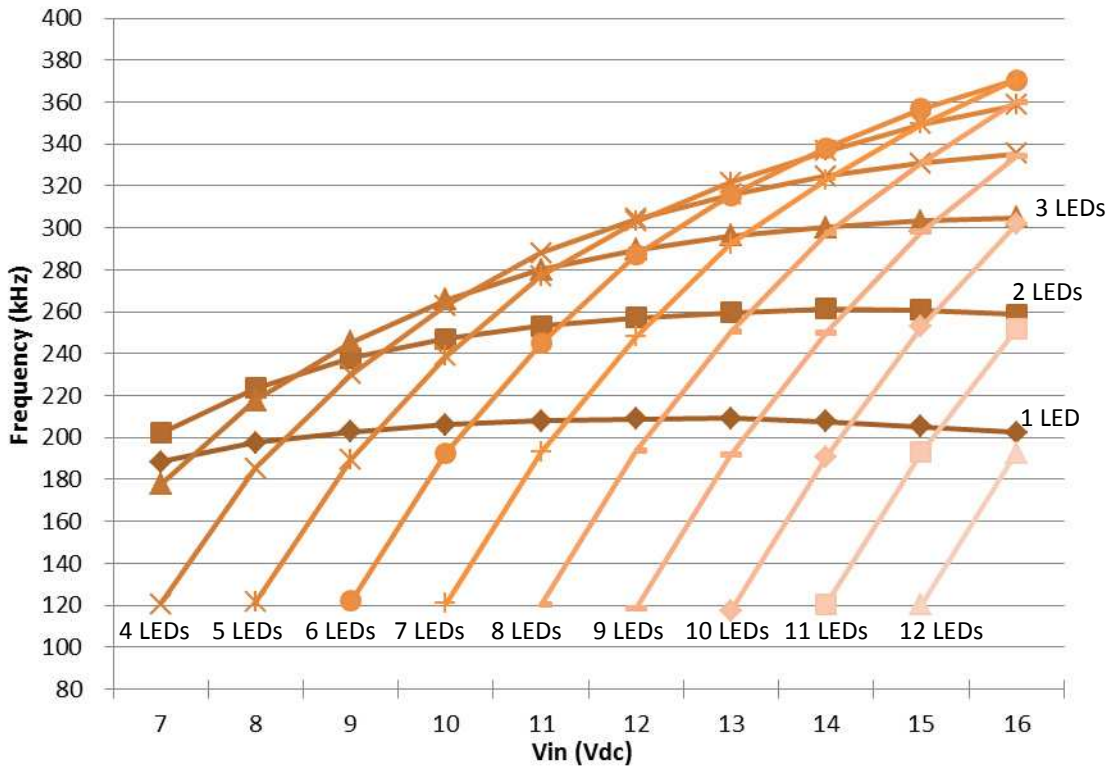

Efficiency vs Vin  
(Forward Voltage = 3.5V per LED)

### Efficiency vs. Input Voltage

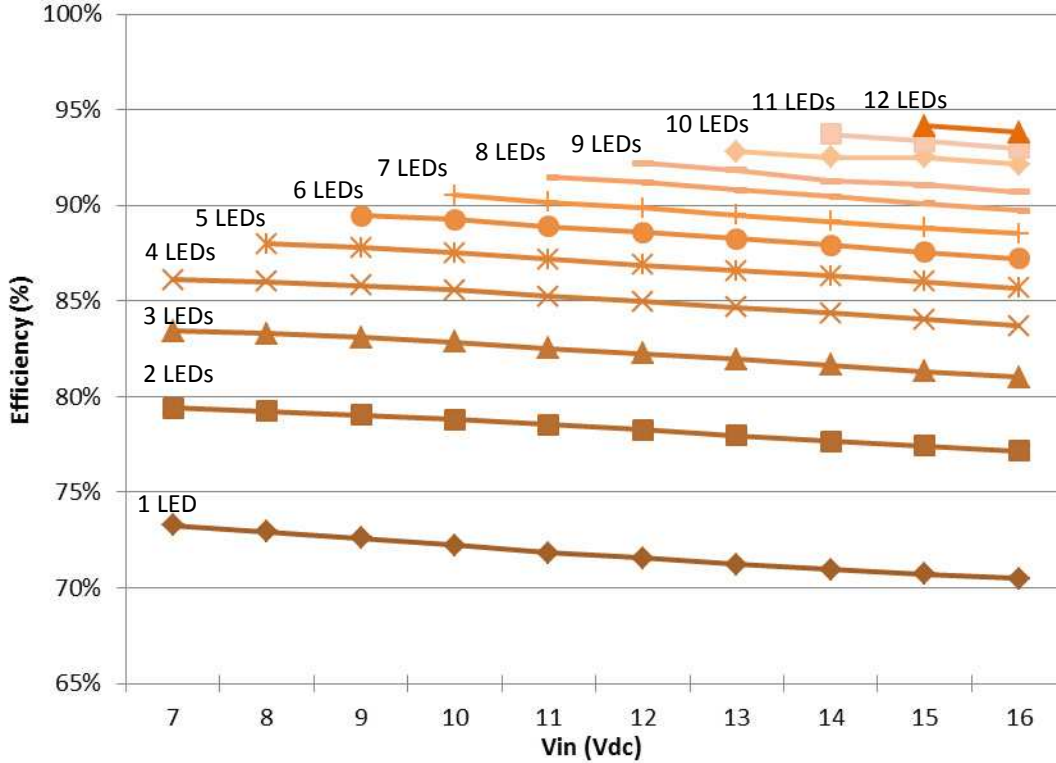

Output Current Vs V<sub>ADJ</sub>

### Output Current vs. V<sub>ADJ</sub>

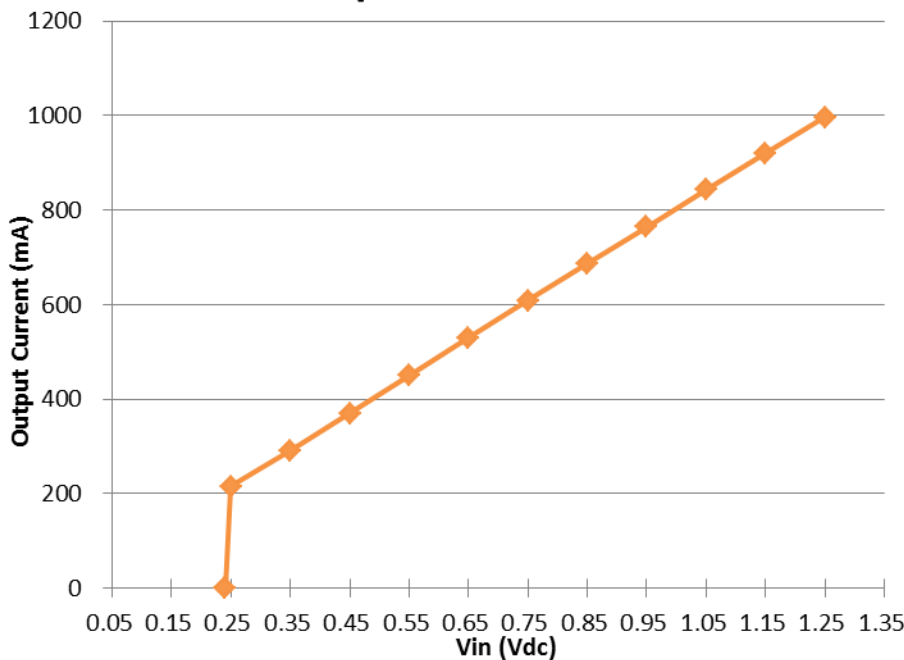

**NOTE:** 1. Datasheets are updated as needed and as such, specifications are subject to change without notice. Once printed or downloaded, datasheets are no longer controlled by Aimtec; refer to [www.aimtec.com](http://www.aimtec.com) for the most current product specifications. 2. Product labels shown, including safety agency certifications on labels, may vary based on the date manufactured. 3. Mechanical drawings and specifications are for reference only. 4. All specifications are measured at an ambient temperature of 25°C, humidity<75%, nominal input voltage and at rated output load unless otherwise specified. 5. Aimtec may not have conducted destructive testing or chemical analysis on all internal components and chemicals at the time of publishing this document. CAS numbers and other limited information are considered proprietary and may not be available for release. 6. This product is not designed for use in critical life support systems, equipment used in hazardous environments, nuclear control systems or other such applications which necessitate specific safety and regulatory standards other than the ones listed in this datasheet. 7. Warranty is in accordance with Aimtec's standard Terms of Sale available at [www.aimtec.com](http://www.aimtec.com).