



# 14-Bit, 135ksp/s, Single-Supply ADCs with Bipolar Analog Input Range

MAX1157/MAX1159/MAX1175

## General Description

The MAX1157/MAX1159/MAX1175 14-bit, low-power, successive-approximation analog-to-digital converters (ADCs) feature automatic power-down, a factory-trimmed internal clock, and a 14-bit wide parallel interface. The devices operate from a single +4.75V to +5.25V analog supply and feature a separate digital supply input for direct interface with +2.7V to +5.25V digital logic.

The MAX1157 accepts an analog input voltage range from 0 to +10V while the MAX1159 accepts a bipolar analog input voltage range of  $\pm 10V$ . The MAX1175 accepts a bipolar analog input voltage range of  $\pm 5V$ . All devices consume only 23mW at a sampling rate of 135ksp/s when using an external reference and 29mW when using the internal +4.096V reference. AutoShutdown™ reduces supply current to 0.4mA at 10ksp/s. The MAX1157/MAX1159/MAX1175 are ideal for high-performance, battery-powered data-acquisition applications. Excellent AC performance (THD = -100dB) and DC accuracy ( $\pm 1LSB$  INL) make the MAX1157/MAX1159/MAX1175 ideal for industrial process control, instrumentation, and medical applications.

The MAX1157/MAX1159/MAX1175 are available in a 28-pin TSSOP package and are fully specified over the -40°C to +85°C extended temperature range and the 0°C to +70°C commercial temperature range.

## Applications

- Temperature Sensing and Monitoring
- Industrial Process Control
- I/O Modules
- Data-Acquisition Systems
- Precision Instrumentation

*AutoShutdown is a trademark of Maxim Integrated Products, Inc.*

## Features

- ◆ Analog Input Voltage Range  $\pm 10V$ ,  $\pm 5V$ , or 0 to 10V
- ◆ 14-Bit Wide Parallel Interface
- ◆ Single +4.75V to +5.25V Analog Supply Voltage
- ◆ Interfaces with +2.7V to +5.25V Digital Logic
- ◆  $\pm 1LSB$  INL (max)
- ◆  $\pm 1LSB$  DNL (max)
- ◆ Low Supply Current (MAX1159)
  - 5.3mA (External Reference)
  - 6.2mA (Internal Reference)
  - 5 $\mu$ A AutoShutdown Mode
- ◆ Small Footprint
  - 28-Pin TSSOP Package

## Pin Configuration

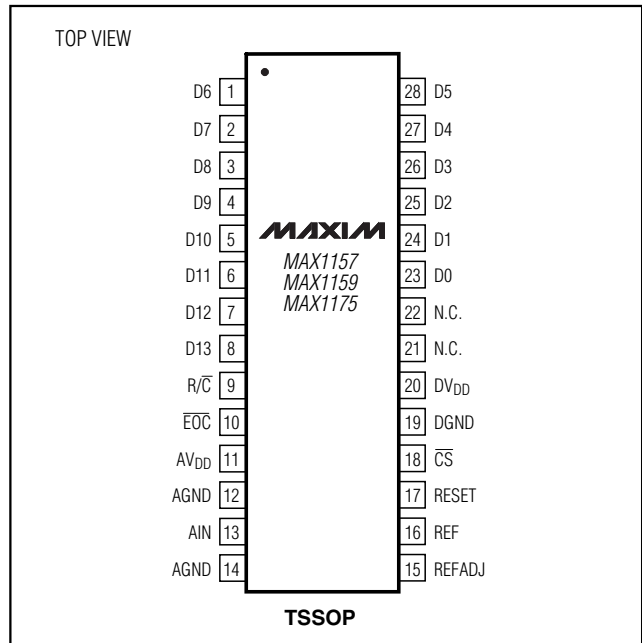

## Ordering Information

PART	TEMP RANGE	PIN-PACKAGE	INPUT VOLTAGE RANGE	INL (LSB)
MAX1157ACUI	0°C to +70°C	28 TSSOP	0 to +10V	$\pm 1$
MAX1157BCUI	0°C to +70°C	28 TSSOP	0 to +10V	$\pm 2$

Ordering Information continued at end of data sheet.



**For pricing, delivery, and ordering information, please contact Maxim/Dallas Direct! at 1-888-629-4642, or visit Maxim's website at [www.maxim-ic.com](http://www.maxim-ic.com).**

# 14-Bit, 135ksps, Single-Supply ADCs with Bipolar Analog Input Range

## ABSOLUTE MAXIMUM RATINGS

AV <sub>DD</sub> to AGND .....	-0.3V to +6V
DV <sub>DD</sub> to DGND.....	-0.3V to +6V
AGND to DGND.....	-0.3V to +0.3V
AIN to AGND .....	-16.5V to +16.5V
REF, REFADJ to AGND.....	-0.3V to (AV <sub>DD</sub> + 0.3V)
CS, R/C, RESET to DGND .....	-0.3V to +6V
D <sub>-</sub> , EOC to DGND .....	-0.3V to (DV <sub>DD</sub> + 0.3V)
Maximum Continuous Current Into Any Pin .....	50mA

Continuous Power Dissipation (T <sub>A</sub> = +70°C)	
28-Pin TSSOP (derate 12.8mW/°C above +70°C) .....	1026mW
Operating Temperature Range	
MAX11__ _CUI.....	0°C to +70°C
MAX11__ _EUI .....	-40°C to +85°C
Storage Temperature Range .....	-65°C to +150°C
Junction Temperature .....	+150°C
Lead Temperature (soldering, 10s) .....	+300°C

Stresses beyond those listed under "Absolute Maximum Ratings" may cause permanent damage to the device. These are stress ratings only, and functional operation of the device at these or any other conditions beyond those indicated in the operational sections of the specifications is not implied. Exposure to absolute maximum rating conditions for extended periods may affect device reliability.

## ELECTRICAL CHARACTERISTICS

(AV<sub>DD</sub> = DV<sub>DD</sub> = +5V ±5%, external reference = +4.096V, C<sub>REF</sub> = 10µF, C<sub>REFADJ</sub> = 0.1µF, V<sub>REFADJ</sub> = AV<sub>DD</sub>, T<sub>A</sub> = T<sub>MIN</sub> to T<sub>MAX</sub>, unless otherwise noted. Typical values are at T<sub>A</sub> = +25°C.)

PARAMETER	SYMBOL	CONDITIONS	MIN	TYP	MAX	UNITS	
<b>DC ACCURACY</b>							
Resolution	RES		14			Bits	
Differential Nonlinearity	DNL	No missing codes over temperature	-1		+1	LSB	
Integral Nonlinearity	INL	MAX11__ _A	-1		+1	LSB	
		MAX11__ _B	-2		+2		
Transition Noise		RMS noise, external reference		0.32		LSB <sub>RMS</sub>	
		Internal reference		0.34			
Offset Error		MAX1159	-10	0	+10	mV	
		MAX1157/MAX1175	-10		+10		
Gain Error				0	±0.2	%FSR	
Offset Drift				16		µV/°C	
Gain Drift				±1		ppm/°C	
<b>AC ACCURACY (f<sub>IN</sub> = 1kHz, V<sub>AIN</sub> = full range, 135ksps)</b>							
Signal-to-Noise Plus Distortion	SINAD		81	85		dB	
Signal-to-Noise Ratio	SNR		82	85		dB	
Total Harmonic Distortion	THD			-100	-86	dB	
Spurious-Free Dynamic Range	SFDR		87	103		dB	
<b>ANALOG INPUT</b>							
Input Range	V <sub>AIN</sub>	MAX1157	0		+10	V	
		MAX1159	-10		+10		
		MAX1175	-5		+5		
Input Resistance	R <sub>AIN</sub>	MAX1157/MAX1175	Normal operation	5.3	6.9	9.2	kΩ
		MAX1175	Shutdown mode	3			
		MAX1157	Shutdown mode	5.3			
		MAX1159	Normal operation	7.8	10	13.0	
			Shutdown mode	6			

# 14-Bit, 135ksps, Single-Supply ADCs with Bipolar Analog Input Range

MAX1157/MAX1159/MAX1175

## ELECTRICAL CHARACTERISTICS (continued)

(AVDD = DVDD = +5V ±5%, external reference = +4.096V, CREF = 10μF, CREFADJ = 0.1μF, VREFADJ = AVDD, TA = TMIN to TMAX, unless otherwise noted. Typical values are at TA = +25°C.)

PARAMETER	SYMBOL	CONDITIONS	MIN	TYP	MAX	UNITS
Input Current	IAIN	MAX1157, 0 ≤ VAIN ≤ +10V	Normal/shutdown mode	-0.1	+2.0	mA
		MAX1159, -10V ≤ VAIN ≤ +10V	Normal operation	-1.8	+1.2	
			Shutdown mode	-1.8	+1.8	
		MAX1175, -5V ≤ VAIN ≤ +5V	Normal operation	-1.8	+0.4	
Shutdown mode	-1.8		+1.8			
Input Current Step at Power-Up	IPU	MAX1159, VAIN = +10V, shutdown mode to operating mode		0.5	0.7	mA
		MAX1175, VAIN = +5V, shutdown mode to operating mode		1	1.4	
Input Capacitance	CIN			10		pF
<b>INTERNAL REFERENCE</b>						
REF Output Voltage	VREF		4.056	4.096	4.136	V
REF Output Tempco				±35		ppm/°C
REF Short-Circuit Current	IREF-SC			±10		mA
<b>EXTERNAL REFERENCE</b>						
REF and REFADJ Input Voltage Range			3.8		4.2	V
REFADJ Buffer Disable Threshold			AVDD - 0.4		AVDD - 0.1	V
REF Input Current	IREF	Normal mode, fSAMPLE = 135ksps		60	100	μA
		Shutdown mode (Note 1)		±0.1	±10	
REFADJ Input Current	IREFADJ	REFADJ = AVDD		16		μA
<b>DIGITAL INPUTS/OUTPUTS</b>						
Output High Voltage	VOH	ISOURCE = 0.5mA, DVDD = +2.7V to +5.25V, AVDD = +5.25V	DVDD - 0.4			V
Output Low Voltage	VOL	ISINK = 1.6mA, DVDD = +2.7V to +5.25V, AVDD = +5.25V			0.4	V
Input High Voltage	VIH		0.7 × DVDD			V
Input Low Voltage	VIL				0.3 × DVDD	V
Input Leakage Current		Digital input = DVDD or 0V	-1		+1	μA
Input Hysteresis	VHYST			0.2		V
Input Capacitance	CIN			15		pF
Three-State Output Leakage	IOZ				±10	μA
Three-State Output Capacitance	COZ			15		pF

# 14-Bit, 135ksps, Single-Supply ADCs with Bipolar Analog Input Range

## ELECTRICAL CHARACTERISTICS (continued)

( $AV_{DD} = DV_{DD} = +5V \pm 5\%$ , external reference = +4.096V,  $C_{REF} = 10\mu F$ ,  $C_{REFADJ} = 0.1\mu F$ ,  $V_{REFADJ} = AV_{DD}$ ,  $T_A = T_{MIN}$  to  $T_{MAX}$ , unless otherwise noted. Typical values are at  $T_A = +25^\circ C$ .)

PARAMETER	SYMBOL	CONDITIONS	MIN	TYP	MAX	UNITS
<b>POWER SUPPLIES</b>						
Analog Supply Voltage	$AV_{DD}$		4.75		5.25	V
Digital Supply Voltage	$DV_{DD}$		2.70		5.25	V
Analog Supply Current	$I_{AVDD}$	External reference, 135ksps	MAX1157		2.9	mA
			MAX1159/MAX1175	4.0	5.3	
		Internal reference, 135ksps	MAX1157		3.8	
			MAX1159/MAX1175	5.2	6.2	
Shutdown Supply Current	$I_{SHDN}$	Shutdown mode (Note 1), digital input = $DV_{DD}$ or 0V		0.5	5	$\mu A$
		Standby mode		3.7		mA
Digital Supply Current	$I_{DVDD}$				0.75	mA
Power-Supply Rejection		$AV_{DD} = DV_{DD} = +4.75V$ to $+5.25V$		1		LSB

## TIMING CHARACTERISTICS (Figures 1 and 2)

( $AV_{DD} = +4.75V$  to  $+5.25V$ ,  $DV_{DD} = +2.7V$  to  $AV_{DD}$ , external reference = +4.096V,  $C_{REF} = 10\mu F$ ,  $C_{REFADJ} = 0.1\mu F$ ,  $V_{REFADJ} = AV_{DD}$ ,  $C_{LOAD} = 20pF$ ,  $T_A = T_{MIN}$  to  $T_{MAX}$ .)

PARAMETER	SYMBOL	CONDITIONS	MIN	TYP	MAX	UNITS
Maximum Sampling Rate	$f_{SAMPLE-MAX}$				135	ksps
Acquisition Time	$t_{ACQ}$		2			$\mu s$
Conversion Time	$t_{CONV}$				4.7	$\mu s$
$\overline{CS}$ Pulse Width High	$t_{CSH}$	(Note 2)	40			ns
$\overline{CS}$ Pulse Width Low	$t_{CSL}$	$DV_{DD} = +4.75V$ to $+5.25V$	40			ns
		$DV_{DD} = +2.7V$ to $+5.25V$	60			
$R/\overline{C}$ to $\overline{CS}$ Fall Setup Time	$t_{DS}$		0			ns
$R/\overline{C}$ to $\overline{CS}$ Fall Hold Time	$t_{DH}$	$DV_{DD} = +4.75V$ to $+5.25V$	40			ns
		$DV_{DD} = +2.7V$ to $+5.25V$	60			
$\overline{CS}$ to Output Data Valid	$t_{DO}$	$DV_{DD} = +4.75V$ to $+5.25V$			40	ns
		$DV_{DD} = +2.7V$ to $+5.25V$			80	
$\overline{EOC}$ Fall to $\overline{CS}$ Fall	$t_{DV}$		0			ns
$\overline{CS}$ Rise to $\overline{EOC}$ Rise	$t_{EOC}$	$DV_{DD} = +4.75V$ to $+5.25V$			40	ns
		$DV_{DD} = +2.7V$ to $+5.25V$			80	
Bus Relinquish Time	$t_{BR}$	$DV_{DD} = +4.75V$ to $+5.25V$			40	ns
		$DV_{DD} = +2.7V$ to $+5.25V$			80	

**Note 1:** Maximum specification is limited by automated test equipment.

**Note 2:** To ensure best performance, finish reading the data and wait  $t_{BR}$  before starting a new acquisition.

# 14-Bit, 135kps, Single-Supply ADCs with Bipolar Analog Input Range

## Typical Operating Characteristics

( $AV_{DD} = DV_{DD} = +5V$ , external reference =  $+4.096V$ ,  $C_{REF} = 10\mu F$ ,  $C_{REFADJ} = 0.1\mu F$ ,  $V_{REFADJ} = AV_{DD}$ ,  $C_{LOAD} = 20pF$ ,  $T_A = T_{MIN}$  to  $T_{MAX}$ , unless otherwise noted. Typical values are at  $T_A = +25^\circ C$ .) (Typical Application Circuit)

MAX1157/MAX1159/MAX1175

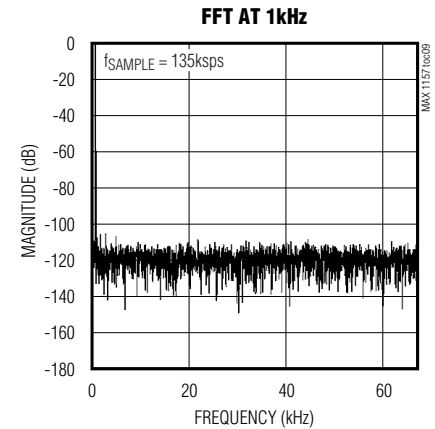
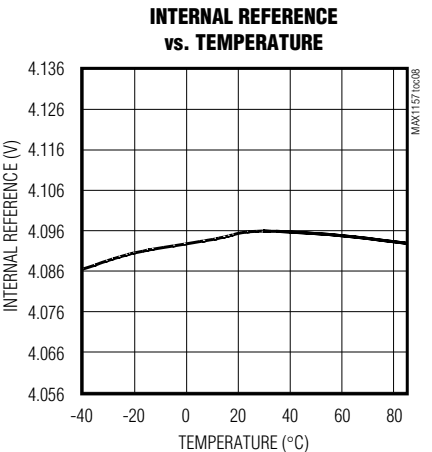
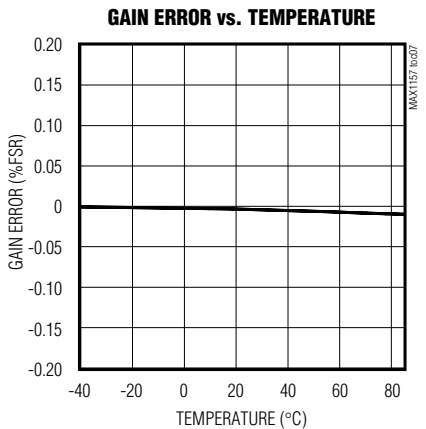
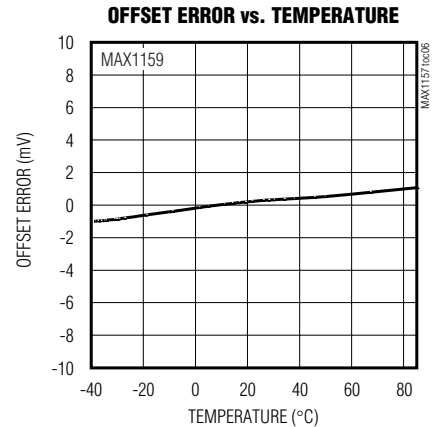
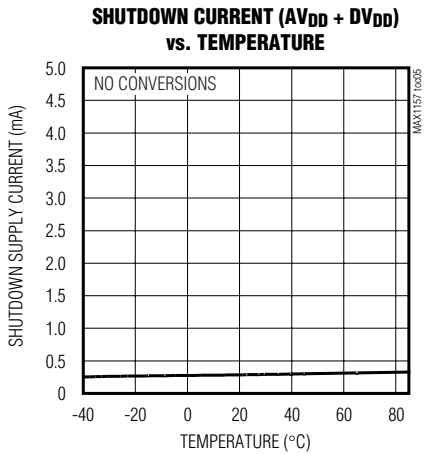
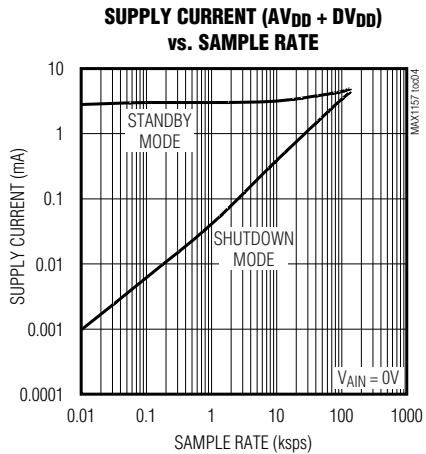
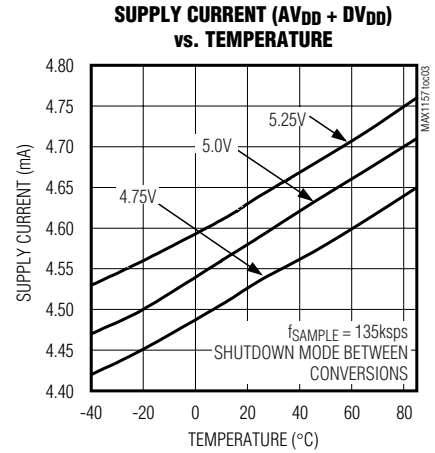
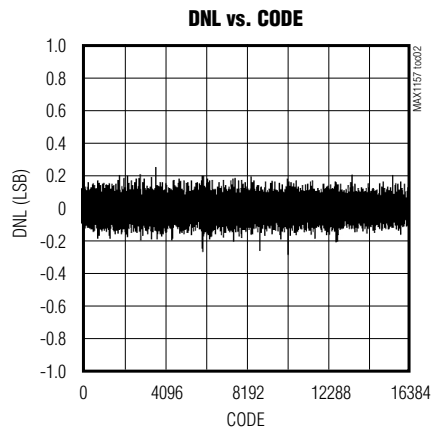
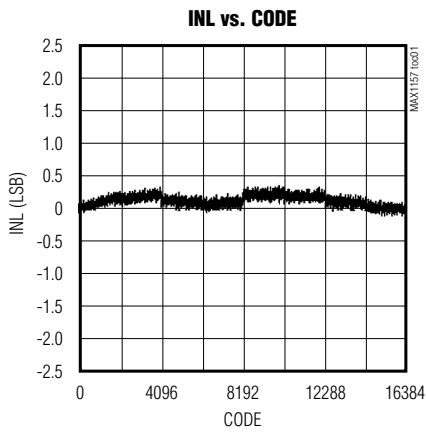

# 14-Bit, 135ksps, Single-Supply ADCs with Bipolar Analog Input Range

## Typical Operating Characteristics

( $AV_{DD} = DV_{DD} = +5V$ , external reference =  $+4.096V$ ,  $C_{REF} = 10\mu F$ ,  $C_{REFADJ} = 0.1\mu F$ ,  $V_{REFADJ} = AV_{DD}$ ,  $C_{LOAD} = 20pF$ ,  $T_A = T_{MIN}$  to  $T_{MAX}$ , unless otherwise noted. Typical values are at  $T_A = +25^\circ C$ .) (Typical Application Circuit)

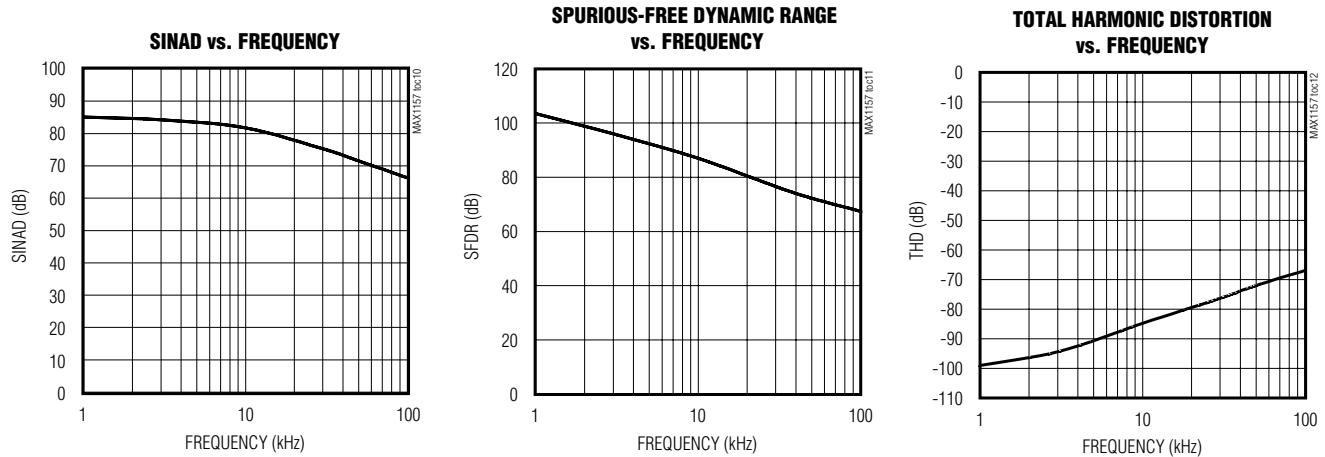

## Pin Description

PIN	NAME	FUNCTION
1	D6	Three-State Digital Data Output
2	D7	Three-State Digital Data Output
3	D8	Three-State Digital Data Output
4	D9	Three-State Digital Data Output
5	D10	Three-State Digital Data Output
6	D11	Three-State Digital Data Output
7	D12	Three-State Digital Data Output
8	D13	Three-State Digital Data Output (MSB)
9	$R/\overline{C}$	Read/ $\overline{Convert}$ Input. Power up and place the MAX1157/MAX1159/MAX1175 in acquisition mode by holding $R/\overline{C}$ low during the first falling edge of $\overline{CS}$ . During the second falling edge of $\overline{CS}$ , the level on $R/\overline{C}$ determines whether the reference and reference buffer power down or remain on after conversion. Set $R/\overline{C}$ high during the second falling edge of $\overline{CS}$ to power down the reference and buffer, or set $R/\overline{C}$ low to leave the reference and buffer powered up. Set $R/\overline{C}$ high during the third falling edge of $\overline{CS}$ to put valid data on the bus.
10	$\overline{EOC}$	End of Conversion. $\overline{EOC}$ drives low when conversion is complete.
11	$AV_{DD}$	Analog Supply Input. Bypass with a $0.1\mu F$ capacitor to AGND.
12	AGND	Analog Ground. Primary analog ground (star ground).
13	AIN	Analog Input
14	AGND	Analog Ground. Connect pin 14 to pin 12.

# 14-Bit, 135ksps, Single-Supply ADCs with Bipolar Analog Input Range

## Pin Description (continued)

MAX1157/MAX1159/MAX1175

PIN	NAME	FUNCTION
15	REFADJ	Reference Buffer Output. Bypass REFADJ with a 0.1 $\mu$ F capacitor to AGND for internal reference mode. Connect REFADJ to AV <sub>DD</sub> to select external reference mode.
16	REF	Reference Input/Output. Bypass REF with a 10 $\mu$ F capacitor to AGND. REF is the external reference input when in external reference mode.
17	RESET	Reset Input. Logic high resets the device.
18	$\overline{CS}$	Convert Start. The first falling edge of $\overline{CS}$ powers up the device and enables acquisition when R/ $\overline{C}$ is low. The second falling edge of $\overline{CS}$ starts conversion. The third falling edge of $\overline{CS}$ loads the result onto the bus when R/ $\overline{C}$ is high.
19	DGND	Digital Ground
20	DV <sub>DD</sub>	Digital Supply Voltage. Bypass with a 0.1 $\mu$ F capacitor to DGND.
21, 22	N.C.	No Connection. Make no connection to these pins.
23	D0	Three-State Digital Data Output (LSB)
24	D1	Three-State Digital Data Output
25	D2	Three-State Digital Data Output
26	D3	Three-State Digital Data Output
27	D4	Three-State Digital Data Output
28	D5	Three-State Digital Data Output

## Detailed Description

### Converter Operation

The MAX1157/MAX1159/MAX1175 use a successive-approximation (SAR) conversion technique with an inherent track-and-hold (T/H) stage to convert an analog input into a 14-bit digital output. Parallel outputs provide a high-speed interface to microprocessors ( $\mu$ Ps). The *Functional Diagram* at the end of the data sheet shows a simplified internal architecture of the MAX1157/MAX1159/MAX1175. Figure 3 shows a typical application circuit for the MAX1157/MAX1159/MAX1175.

### Analog Input Input Scaler

The MAX1157/MAX1159/MAX1175 have an input scaler which allows conversion of true bipolar input voltages and input voltages greater than the power supply, while operating from a single +5V analog supply. The input scaler attenuates and shifts the analog input to match the input range of the internal DAC. The MAX1157 has a unipolar input voltage range of 0 to +10V. The

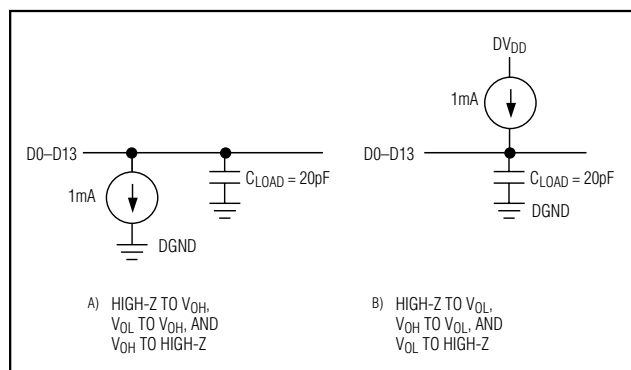

Figure 1. Load Circuits

MAX1175 input voltage range is  $\pm 5V$  while the MAX1159 input voltage range is  $\pm 10V$ . Figure 4 shows the equivalent input circuit of the MAX1157/MAX1159/MAX1175. This circuit limits the current going into or out of AIN to less than 1.8mA.

# 14-Bit, 135kps, Single-Supply ADCs with Bipolar Analog Input Range

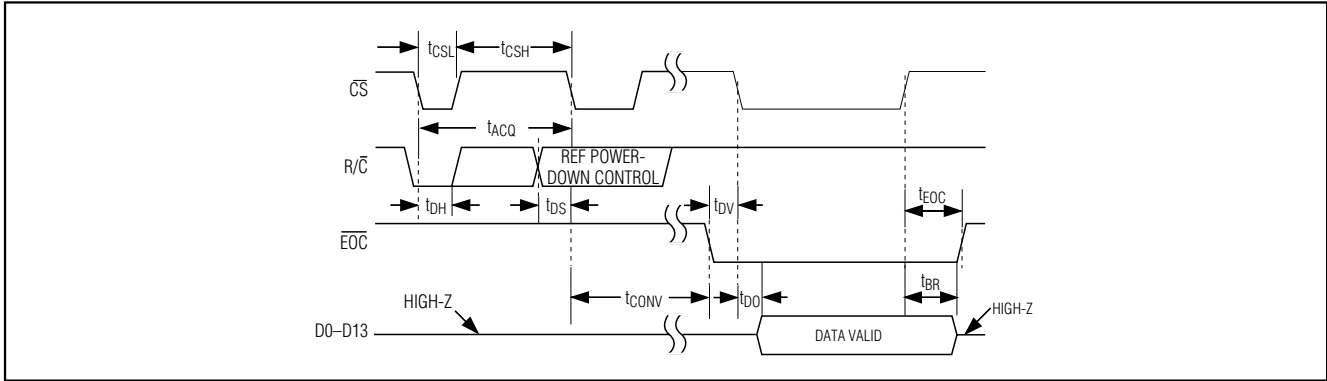

Figure 2. MAX1157/MAX1159/MAX1175 Timing Diagram

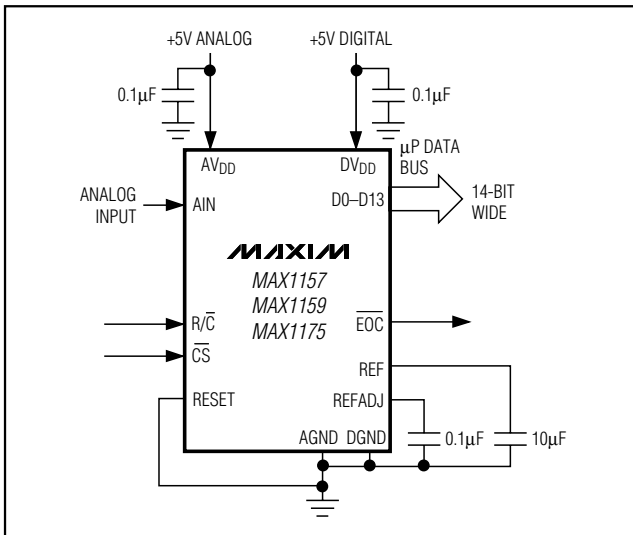

Figure 3. Typical Application Circuit for the MAX1157/MAX1159/MAX1175

### Track and Hold (T/H)

In track mode, the internal hold capacitor acquires the analog signal (see Figure 4). In hold mode, the T/H switches open and the capacitive DAC samples the analog input. During the acquisition, the analog input (AIN) charges capacitor  $C_{HOLD}$ . The acquisition ends on the second falling edge of  $\overline{CS}$ . At this instant, the T/H switches open. The retained charge on  $C_{HOLD}$  represents a sample of the input. In hold mode, the capacitive DAC adjusts during the remainder of the conversion time to restore node T/H OUT to zero within the limits of 14-bit resolution. Force  $\overline{CS}$  low to put valid data on the bus after conversion is complete.

### Power-Down Modes

Select standby mode or shutdown mode with  $\overline{R/C}$  during the second falling edge of  $\overline{CS}$  (see *Selecting Standby or Shutdown Mode* section). The MAX1157/MAX1159/MAX1175 automatically enter either standby mode (reference and buffer on), or shutdown (reference and buffer off) after each conversion depending on the status of  $\overline{R/C}$  during the second falling edge of  $\overline{CS}$ .

### Internal Clock

The MAX1157/MAX1159/MAX1175 generate an internal conversion clock to free the microprocessor from the burden of running the SAR conversion clock. Total conversion time after entering hold mode (second falling edge of  $\overline{CS}$ ) to end-of-conversion (EOC) falling is 4.7µs (max).

## Applications Information

### Starting a Conversion

$\overline{CS}$  and  $\overline{R/C}$  control acquisition and conversion in the MAX1157/MAX1159/MAX1175 (see Figure 2). The first falling edge of  $\overline{CS}$  powers up the device and puts it in acquire mode if  $\overline{R/C}$  is low. The convert start  $\overline{CS}$  is ignored if  $\overline{R/C}$  is high. The MAX1157/MAX1159/MAX1175 need at least 6ms ( $C_{REFADJ} = 0.1\mu\text{F}$ ,  $C_{REF} = 10\mu\text{F}$ ) for the internal reference to wake up and settle before starting the conversion if powering up from shutdown. Reset the MAX1157/MAX1159/MAX1175 by toggling RESET with  $\overline{CS}$  high. The next falling edge of  $\overline{CS}$  begins acquisition.

### Selecting Standby or Shutdown Mode

The MAX1157/MAX1159/MAX1175 have a selectable standby or low-power shutdown mode. In standby mode, the ADC's internal reference and reference buffer do not power down between conversions, eliminating the need to wait for the reference to power up before performing the next conversion. Shutdown mode



# 14-Bit, 135kps, Single-Supply ADCs with Bipolar Analog Input Range

MAX1157/MAX1159/MAX1175

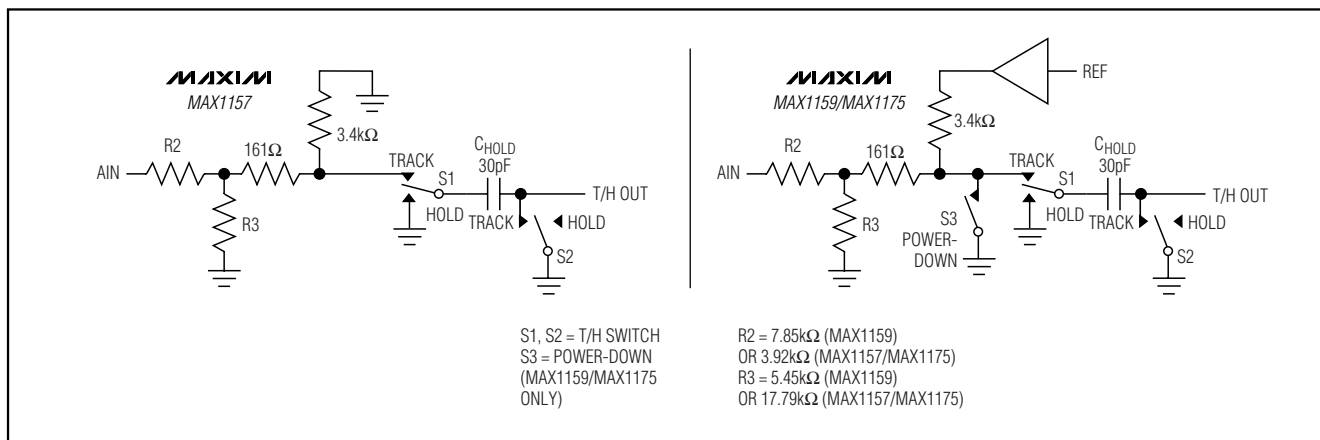

Figure 4. Equivalent Input Circuit

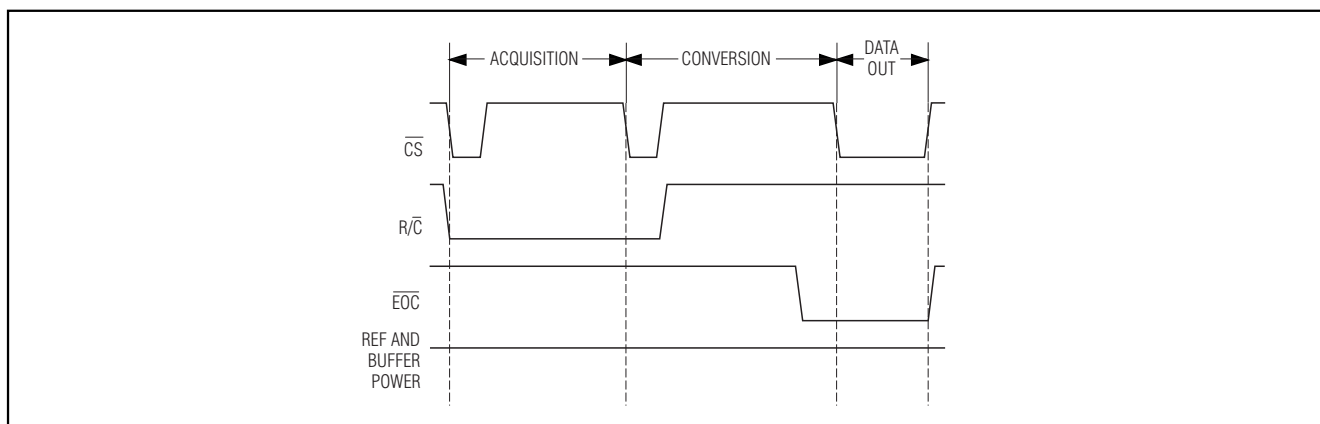

Figure 5. Selecting Standby Mode

powers down the reference and reference buffer after completing a conversion. The reference and reference buffer require a minimum of 12ms ( $C_{REFADJ} = 0.1\mu\text{F}$ ,  $C_{REF} = 10\mu\text{F}$ ) to power up and settle from shutdown.

The state of  $R/\bar{C}$  during the second falling edge of  $\bar{CS}$  selects which power-down mode the MAX1157/MAX1159/MAX1175 enters upon conversion completion. Holding  $R/\bar{C}$  low causes the MAX1157/MAX1159/MAX1175 to enter standby mode. The reference and buffer are left on after the conversion completes.  $R/\bar{C}$  high causes the MAX1157/MAX1159/MAX1175 to enter shutdown mode and power down the reference and buffer after conversion (see Figures 5 and 6). Set the voltage at REF high during the second falling edge of  $\bar{CS}$  to realize the lowest current operation.

### Standby Mode

While in standby mode, the supply current is less than 3.7mA (typ). The next falling edge of  $\bar{CS}$  with  $R/\bar{C}$  low causes the MAX1157/MAX1159/MAX1175 to exit standby mode and begin acquisition. The reference and reference buffer remain active to allow quick turn-on time.

# 14-Bit, 135ksps, Single-Supply ADCs with Bipolar Analog Input Range

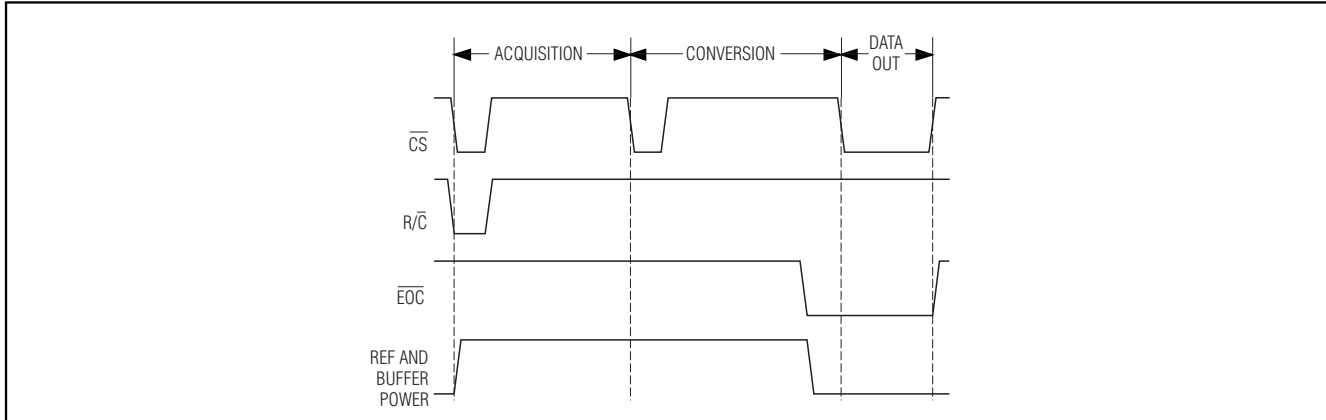

Figure 6. Selecting Shutdown Mode

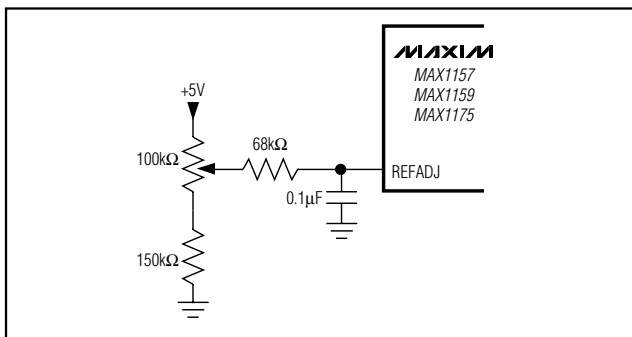

Figure 7. MAX1157/MAX1159/MAX1175 Reference Adjust Circuit

## Shutdown Mode

In shutdown mode, the reference and reference buffer shut down between conversions. Shutdown mode reduces supply current to 0.5μA (typ) immediately after the conversion. The next falling edge of  $\overline{CS}$  with  $R/\overline{C}$  low causes the reference and buffer to wake up and enter acquisition mode. To achieve 14-bit accuracy, allow 12ms ( $C_{REFADJ} = 0.1\mu\text{F}$ ,  $C_{REF} = 10\mu\text{F}$ ) for the internal reference to wake up.

## Internal and External Reference

### Internal Reference

The internal reference of the MAX1157/MAX1159/MAX1175 is internally buffered to provide +4.096V output at REF. Bypass REF to AGND and REFADJ to AGND with 10μF and 0.1μF, respectively.

Sink or source current at REFADJ to make fine adjustments to the internal reference. The input impedance of REFADJ is nominally 5kΩ. Use the circuit of Figure 7 to adjust the internal reference to ±1.5%.

### External Reference

An external reference can be placed at either the input (REFADJ) or the output (REF) of the MAX1157/MAX1159/MAX1175's internal buffer amplifier. Using the buffered REFADJ input makes buffering the external reference unnecessary. The input impedance of REFADJ is typically 5kΩ. The internal buffer output must be bypassed at REF with a 10μF capacitor.

Connect REFADJ to  $AV_{DD}$  to disable the internal buffer. Directly drive REF using an external 3.8V to 4.2V reference. During conversion, the external reference must be able to drive 100μA of DC load current and have an output impedance of 10Ω or less.

For optimal performance, buffer the reference through an op amp and bypass REF with a 10μF capacitor. Consider the MAX1157/MAX1159/MAX1175's equivalent input noise (0.6LSB) when choosing a reference.

### Reading the Conversion Result

$\overline{EOC}$  flags the microprocessor when a conversion is complete. The falling edge of  $\overline{EOC}$  signals that the data is valid and ready to be output to the bus. D0–D13 are the parallel outputs of the MAX1157/MAX1159/MAX1175. These three-state outputs allow for direct connection to a microcontroller I/O bus. The outputs remain high-impedance during acquisition and conversion. Data is loaded onto the bus with the third falling edge of  $\overline{CS}$  with  $R/\overline{C}$  high (after  $t_{DO}$ ). Bringing  $\overline{CS}$  high forces the output bus back to high impedance. The MAX1157/MAX1159/MAX1175 then wait for the next falling edge of  $\overline{CS}$  to start the next conversion cycle (see Figure 2).

# 14-Bit, 135kps, Single-Supply ADCs with Bipolar Analog Input Range

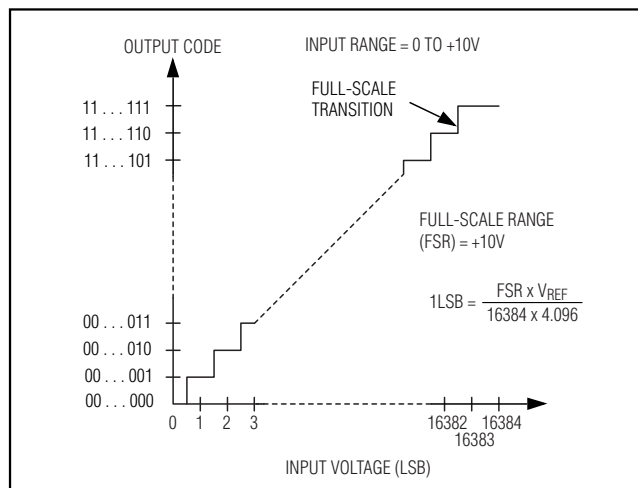

Figure 8. MAX1157 Transfer Function

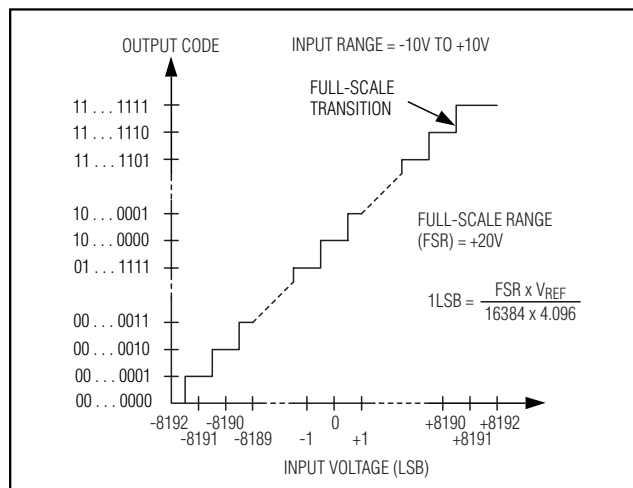

Figure 9. MAX1159 Transfer Function

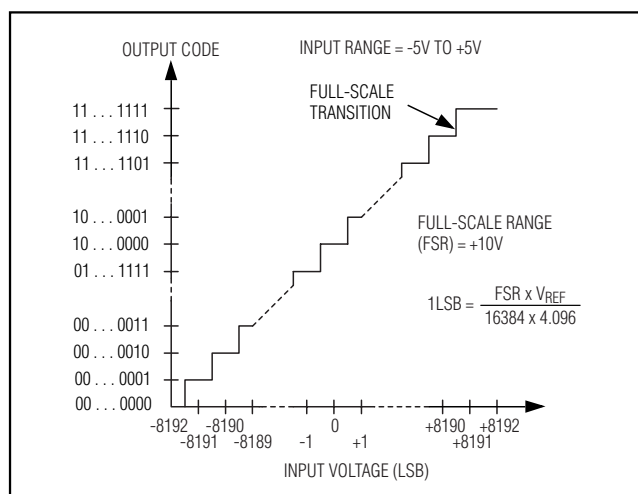

Figure 10. MAX1175 Transfer Function

## Transfer Function

Figures 8, 9, and 10 show the MAX1157/MAX1159/MAX1175's output transfer functions. The MAX1159 and MAX1175 outputs are coded in offset binary, while the MAX1157 is coded on standard binary.

## Input Buffer

Most applications require an input buffer amplifier to achieve 14-bit accuracy and prevent loading the source. Switch the channels immediately after acquisition, rather than near the end of or after a conversion when the input signal is multiplexed. This allows more time for the input buffer amplifier to respond to a large

step-change in input signal. The input amplifier must have a high enough slew rate to complete the required output voltage change before the beginning of the acquisition time. Figure 11 shows an example of this circuit using the MAX427.

Figures 12a and 12b show how the MAX1175 and MAX1159 analog input current varies depending on whether the chip is operating or powered down. The part is fully powered down between conversions if the voltage at R/C is set high during the second falling edge of CS. The input current abruptly steps to the powered up value at the start of acquisition. This step in the input current can disrupt the ADC input, depending on the driving circuit's output impedance at high frequencies. If the driving circuit cannot fully settle by the end of acquisition time, the accuracy of the system can be compromised. To avoid this situation, increase the acquisition time, use a driving circuit that can settle within  $t_{\text{ACQ}}$ , or leave the MAX1175/MAX1159 powered up by setting the voltage at R/C low during the second falling edge of CS.

## Layout, Grounding, and Bypassing

For best performance, use printed circuit (PC) boards. Do not run analog and digital lines parallel to each other, and do not lay out digital signal paths underneath the ADC package. Use separate analog and digital ground planes with only one point connecting the two ground systems (analog and digital) as close to the device as possible.

Route digital signals far away from sensitive analog and reference inputs. If digital lines must cross analog lines, do so at right angles to minimize coupling digital noise

# 14-Bit, 135ksp/s, Single-Supply ADCs with Bipolar Analog Input Range

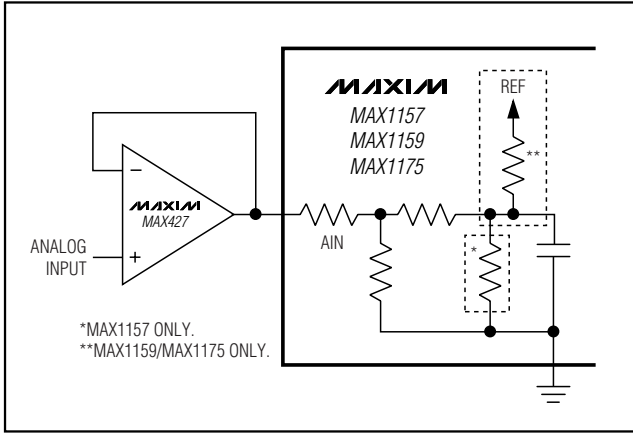

Figure 11. MAX1157/MAX1159/MAX1175 Fast-Settling Input Buffer

onto the analog lines. If the analog and digital sections share the same supply, isolate the digital and analog supply by connecting them with a low value (10Ω) resistor or ferrite bead.

The ADC is sensitive to high-frequency noise on the AVDD supply. Bypass AVDD to AGND with a 0.1μF capacitor in parallel with a 1μF to 10μF low-ESR capacitor with the smallest capacitor closest to the device. Keep capacitor leads short to minimize stray inductance

## Definitions

### Integral Nonlinearity

Integral nonlinearity (INL) is the deviation of the values on an actual transfer function from a straight line. This straight line can be either a best-straight-line fit or a line drawn between the end points of the transfer function, once offset and gain errors have been nullified. The static linearity parameters for the MAX1157/MAX1159/MAX1175 are measured using the endpoint method.

### Differential Nonlinearity

Differential nonlinearity (DNL) is the difference between an actual step-width and the ideal value of 1LSB. A DNL error specification of 1LSB guarantees no missing codes and a monotonic transfer function.

### Signal-to-Noise Ratio

For a waveform perfectly reconstructed from digital samples, signal-to-noise ratio (SNR) is the ratio of the full-scale analog input (RMS value) to the RMS quantization error (residual error). The ideal, theoretical minimum analog-to-digital noise is caused by quantization noise error only and results directly from the ADC's resolution (N bits):

$$SNR = ((6.02 \times N) + 1.76)dB$$

where N = 14 bits.

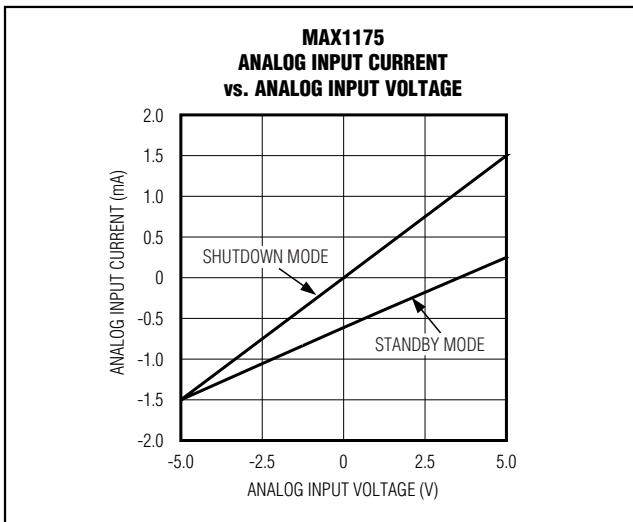

Figure 12a. MAX1175 Analog Input Current

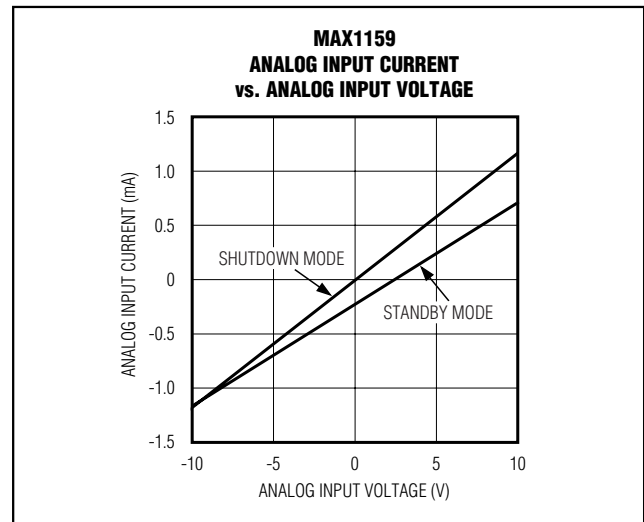

Figure 12b. MAX1159 Analog Input Current

# 14-Bit, 135kps, Single-Supply ADCs with Bipolar Analog Input Range

In reality, there are other noise sources besides quantization noise: thermal noise, reference noise, clock jitter, etc. SNR is computed by taking the ratio of the RMS signal to the RMS noise, which includes all spectral components minus the fundamental, the first five harmonics, and the DC offset.

## Signal-to-Noise Plus Distortion

Signal-to-noise plus distortion (SINAD) is the ratio of the fundamental input frequency's RMS amplitude to the RMS equivalent of all the other ADC output signals.

$$\text{SINAD}(\text{db}) = 20 \times \log \left( \frac{\text{Signal}_{\text{RMS}}}{(\text{Noise} + \text{Distortion})_{\text{RMS}}} \right)$$

## Effective Number of Bits

Effective number of bits (ENOB) indicates the global accuracy of an ADC at a specific input frequency and sampling rate. An ideal ADC's error consists of quantization noise only. With an input range equal to the full-scale range of the ADC, calculate the effective number of bits as follows:

$$\text{ENOB} = \left( \frac{\text{SINAD} - 1.76}{6.02} \right)$$

## Total Harmonic Distortion

Total harmonic distortion (THD) is the ratio of the RMS sum of the first five harmonics of the input signal to the fundamental itself. This is expressed as:

$$\text{THD} = 20 \times \log \left( \frac{\left( \sqrt{V_2^2 + V_3^2 + V_4^2 + V_5^2} \right)}{V_1} \right)$$

where  $V_1$  is the fundamental amplitude and  $V_2$  through  $V_5$  are the 2nd- through 5th-order harmonics.

## Spurious-Free Dynamic Range

Spurious-free dynamic range (SFDR) is the ratio of the RMS amplitude of the fundamental (maximum signal component) to the RMS value of the next largest frequency component.

## Chip Information

TRANSISTOR COUNT: 15,383

PROCESS: BiCMOS

## Ordering Information (continued)

PART	TEMP RANGE	PIN-PACKAGE	INPUT VOLTAGE RANGE	INL (LSB)
MAX1157AEUI	-40°C to +85°C	28 TSSOP	0 to +10V	±1
MAX1157BEUI	-40°C to +85°C	28 TSSOP	0 to +10V	±2
<b>MAX1159</b> ACUI	0°C to +70°C	28 TSSOP	±10V	±1
MAX1159BCUI	0°C to +70°C	28 TSSOP	±10V	±2
MAX1159AEUI*	-40°C to +85°C	28 TSSOP	±10V	±1
MAX1159BEUI*	-40°C to +85°C	28 TSSOP	±10V	±2
<b>MAX1175</b> ACUI	0°C to +70°C	28 TSSOP	±5V	±1
MAX1175BCUI	0°C to +70°C	28 TSSOP	±5V	±2
MAX1175AEUI	-40°C to +85°C	28 TSSOP	±5V	±1
MAX1175BEUI	-40°C to +85°C	28 TSSOP	±5V	±2

\*Future product—contact factory for availability.

# 14-Bit, 135ksps, Single-Supply ADCs with Bipolar Analog Input Range

Functional Diagram

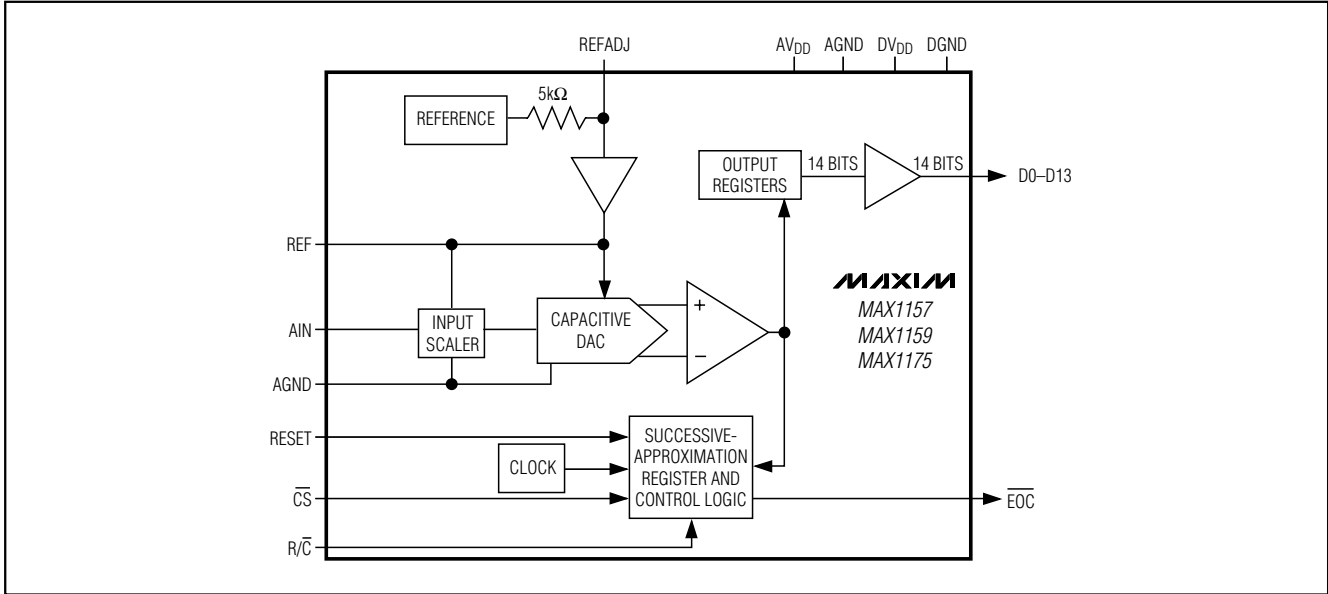

# 14-Bit, 135kps, Single-Supply ADCs with Bipolar Analog Input Range

## Package Information

(The package drawing(s) in this data sheet may not reflect the most current specifications. For the latest package outline information, go to [www.maxim-ic.com/packages](http://www.maxim-ic.com/packages).)

MAX1157/MAX1159/MAX1175

TSSOP4-4.0mm, EPS

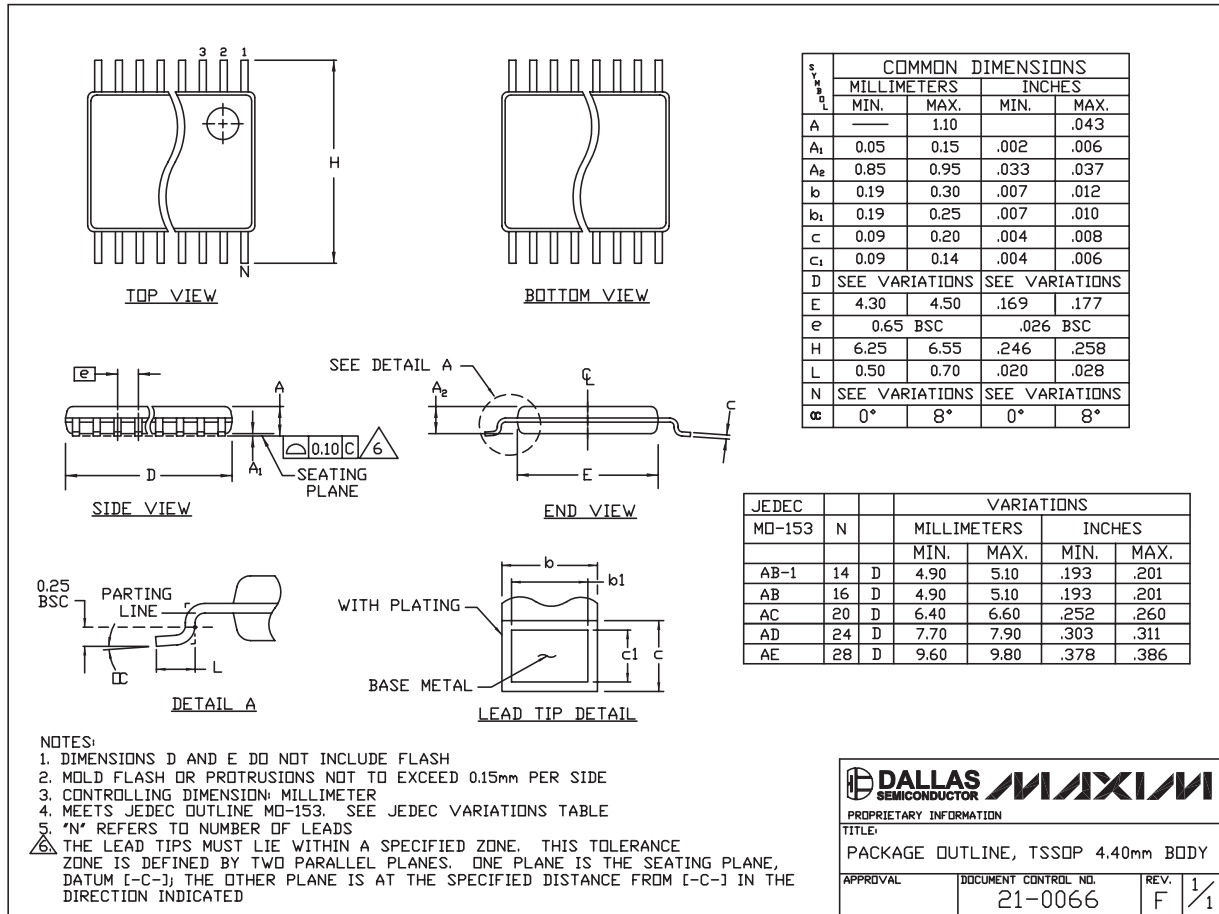

Maxim cannot assume responsibility for use of any circuitry other than circuitry entirely embodied in a Maxim product. No circuit patent licenses are implied. Maxim reserves the right to change the circuitry and specifications without notice at any time.

Maxim Integrated Products, 120 San Gabriel Drive, Sunnyvale, CA 94086 408-737-7600 15