



Dual, Ultra-Low-Power, 10-Bit, Voltage-Output DACs

MAX5522-MAX5525

General Description

The MAX5522–MAX5525 are dual, 10-bit, ultra-low-power, voltage-output, digital-to-analog converters (DACs) offering rail-to-rail buffered voltage outputs. The DACs operate from a 1.8V to 5.5V supply and consume less than 5 μ A, making the devices suitable for low-power and low-voltage applications. A shutdown mode reduces overall current, including the reference input current, to just 0.18 μ A. The MAX5522–MAX5525 use a 3-wire serial interface that is compatible with SPI™, QSPI™, and MICROWIRE™.

Upon power-up, the MAX5522–MAX5525 outputs are driven to zero scale, providing additional safety for applications that drive valves or for other transducers that need to be off during power-up. The zero-scale outputs enable glitch-free power-up.

The MAX5522 accepts an external reference input and provides unity-gain outputs. The MAX5523 contains a precision internal reference and provides a buffered external reference output with unity-gain DAC outputs. The MAX5524 accepts an external reference input and provides force-sense outputs. The MAX5525 contains a precision internal reference and provides a buffered external reference output with force-sense DAC outputs.

The MAX5524/MAX5525 are available in a 4mm x 4mm x 0.8mm, 12-pin, thin QFN package. The MAX5522/MAX5523 are available in an 8-pin μ MAX package. All devices are guaranteed over the extended -40°C to +85°C temperature range.

For 12-bit compatible devices, refer to the MAX5532–MAX5535 data sheet. For 8-bit compatible devices, refer to the MAX5512–MAX5515 data sheet.

Applications

Portable Battery-Powered Devices
Instrumentation
Automatic Trimming and Calibration in Factory or Field
Programmable Voltage and Current Sources
Industrial Process Control and Remote Industrial Devices
Remote Data Conversion and Monitoring
Chemical Sensor Cell Bias for Gas Monitors
Programmable LCD Bias

SPI and QSPI are trademarks of Motorola, Inc.
MICROWIRE is a trademark of National Semiconductor Corp.



Features

- ◆ Ultra-Low 5 μ A Supply Current
- ◆ Shutdown Mode Reduces Supply Current to 0.18 μ A (max)
- ◆ Single +1.8V to +5.5V Supply
- ◆ Small 4mm x 4mm x 0.8mm Thin QFN Package
- ◆ Internal Reference Sources 8mA of Current (MAX5523/MAX5525)
- ◆ Flexible Force-Sense-Configured Rail-to-Rail Output Buffers
- ◆ Fast 16MHz, 3-Wire, SPI-/QSPI-/MICROWIRE-Compatible Serial Interface
- ◆ TTL- and CMOS-Compatible Digital Inputs with Hysteresis
- ◆ Glitch-Free Outputs During Power-Up

Ordering Information

PART	TEMP RANGE	PIN-PACKAGE
MAX5522EUA	-40°C to +85°C	8 μ MAX
MAX5523EUA	-40°C to +85°C	8 μ MAX
MAX5524ETC	-40°C to +85°C	12 Thin QFN-EP*
MAX5525ETC	-40°C to +85°C	12 Thin QFN-EP*

*EP = Exposed paddle (internally connected to GND).

Selector Guide

PART	OUTPUTS	REFERENCE	TOP MARK
MAX5522EUA	Unity gain	External	—
MAX5523EUA	Unity gain	Internal	—
MAX5524ETC	Force sense	External	AACK
MAX5525ETC	Force sense	Internal	AACL

Pin Configurations

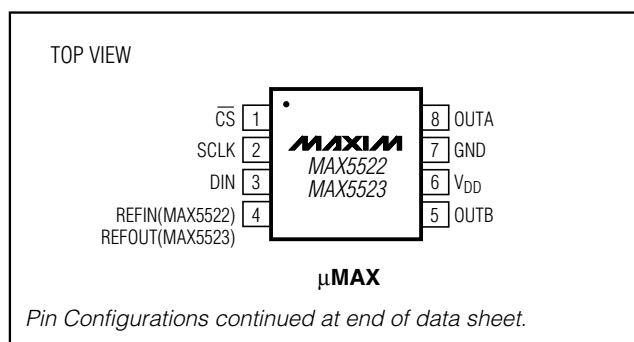

Dual, Ultra-Low-Power, 10-Bit, Voltage-Output DACs

ABSOLUTE MAXIMUM RATINGS

V _{DD} to GND	-0.3V to +6V
OUTA, OUTB to GND	-0.3V to (V _{DD} + 0.3V)
FBA, FBB to GND	-0.3V to (V _{DD} + 0.3V)
SCLK, DIN, CS to GND	-0.3V to (V _{DD} + 0.3V)
REFIN, REFOUT to GND	-0.3V to (V _{DD} + 0.3V)
Continuous Power Dissipation (T _A = +70°C)	
12-Pin Thin QFN (derate 16.9mW/°C above +70°C)	1349mW
8-Pin μMAX (derate 5.9mW/°C above +70°C)	471mW

Operating Temperature Range	-40°C to +85°C
Storage Temperature Range	-65°C to +150°C
Junction Temperature	+150°C
Lead Temperature (soldering, 10s)	+300°C

Stresses beyond those listed under "Absolute Maximum Ratings" may cause permanent damage to the device. These are stress ratings only, and functional operation of the device at these or any other conditions beyond those indicated in the operational sections of the specifications is not implied. Exposure to absolute maximum rating conditions for extended periods may affect device reliability.

ELECTRICAL CHARACTERISTICS

(V_{DD} = +1.8V to +5.5V, OUT_ unloaded, T_A = T_{MIN} to T_{MAX}, unless otherwise noted. Typical values are at T_A = +25°C.)

PARAMETER	SYMBOL	CONDITIONS	MIN	TYP	MAX	UNITS
STATIC ACCURACY (MAX5522/MAX5524 EXTERNAL REFERENCE)						
Resolution	N		10			Bits
Integral Nonlinearity (Note 1)	INL	V _{DD} = 5V, V _{REF} = 4.096V		±1	±4	LSB
		V _{DD} = 1.8V, V _{REF} = 1.024V		±1	±4	
Differential Nonlinearity (Note 1)	DNL	Guaranteed monotonic, V _{DD} = 5V, V _{REF} = 4.096V		±0.2	±1	LSB
		Guaranteed monotonic, V _{DD} = 1.8V, V _{REF} = 1.024V		±0.2	±1	
Offset Error (Note 2)	V _{OS}	V _{DD} = 5V, V _{REF} = 4.096V		±1	±20	mV
		V _{DD} = 1.8V, V _{REF} = 1.024V		±1	±20	
Offset-Error Temperature Drift				±2		μV/°C
Gain Error (Note 3)	GE	V _{DD} = 5V, V _{REF} = 4.096V		±0.5	±2	LSB
		V _{DD} = 1.8V, V _{REF} = 1.024V		±0.5	±2	
Gain-Error Temperature Coefficient				±4		ppm/°C
Power-Supply Rejection Ratio	PSRR	1.8V ≤ V _{DD} ≤ 5.5V		85		dB
STATIC ACCURACY (MAX5523/MAX5525 INTERNAL REFERENCE)						
Resolution	N		10			Bits
Integral Nonlinearity (Note 1)	INL	V _{DD} = 5V, V _{REF} = 3.9V		±1	±4	LSB
		V _{DD} = 1.8V, V _{REF} = 1.2V		±1	±4	
Differential Nonlinearity (Note 1)	DNL	Guaranteed monotonic, V _{DD} = 5V, V _{REF} = 3.9V		±0.2	±1	LSB
		Guaranteed monotonic, V _{DD} = 1.8V, V _{REF} = 1.2V		±0.2	±1	
Offset Error (Note 2)	V _{OS}	V _{DD} = 5V, V _{REF} = 3.9V		±1	±20	mV
		V _{DD} = 1.8V, V _{REF} = 1.2V		±1	±20	
Offset-Error Temperature Drift				±2		μV/°C
Gain Error (Note 3)	GE	V _{DD} = 5V, V _{REF} = 3.9V		±0.5	±2	LSB
		V _{DD} = 1.8V, V _{REF} = 1.2V		±0.5	±2	
Gain-Error Temperature Coefficient				±4		ppm/°C

Dual, Ultra-Low-Power, 10-Bit, Voltage-Output DACs

MAX5522-MAX5525

ELECTRICAL CHARACTERISTICS (continued)

($V_{DD} = +1.8V$ to $+5.5V$, OUT_+ unloaded, $T_A = T_{MIN}$ to T_{MAX} , unless otherwise noted. Typical values are at $T_A = +25^\circ C$.)

PARAMETER	SYMBOL	CONDITIONS	MIN	TYP	MAX	UNITS
Power-Supply Rejection Ratio	PSRR	$1.8V \leq V_{DD} \leq 5.5V$		85		dB
REFERENCE INPUT (MAX5522/MAX5524)						
Reference-Input Voltage Range	V_{REFIN}		0		V_{DD}	V
Reference-Input Impedance	R_{REFIN}	Normal operation	4.1			$M\Omega$
		In shutdown		2.5		$G\Omega$
REFERENCE OUTPUT (MAX5523/MAX5525)						
Initial Accuracy	V_{REFOUT}	No external load, $V_{DD} = 1.8V$	1.197	1.214	1.231	V
		No external load, $V_{DD} = 2.5V$	1.913	1.940	1.967	
		No external load, $V_{DD} = 3V$	2.391	2.425	2.459	
		No external load, $V_{DD} = 5V$	3.828	3.885	3.941	
Output-Voltage Temperature Coefficient	V_{TEMPCO}	$T_A = -40^\circ C$ to $+85^\circ C$ (Note 4)		12	30	ppm/ $^\circ C$
Line Regulation		$V_{REFOUT} < V_{DD} - 200mV$ (Note 5)		2	200	$\mu V/V$
Load Regulation		$0 \leq I_{REFOUT} \leq 1mA$, sourcing, $V_{DD} = 1.8V$, $V_{REF} = 1.2V$		0.3	2	$\mu V/\mu A$
		$0 \leq I_{REFOUT} \leq 8mA$, sourcing, $V_{DD} = 5V$, $V_{REF} = 3.9V$		0.3	2	
		$-150\mu A \leq I_{REFOUT} \leq 0$, sinking		0.2		
Output Noise Voltage		0.1Hz to 10Hz, $V_{REF} = 3.9V$		150		μV_{P-P}
		10Hz to 10kHz, $V_{REF} = 3.9V$		600		
		0.1Hz to 10Hz, $V_{REF} = 1.2V$		50		
		10Hz to 10kHz, $V_{REF} = 1.2V$		450		
Short-Circuit Current (Note 6)		$V_{DD} = 5V$		30		mA
		$V_{DD} = 1.8V$		14		
Capacitive Load Stability Range		(Note 7)		0 to 10		nF
Thermal Hysteresis		(Note 8)		200		ppm
Reference Power-Up Time (from Shutdown)		REFOUT unloaded, $V_{DD} = 5V$		5.4		ms
		REFOUT unloaded, $V_{DD} = 1.8V$		4.4		
Long-Term Stability				200		ppm/ 1khrs
DAC OUTPUTS (OUTA, OUTB)						
Capacitive Driving Capability	C_L			1000		pF
Short-Circuit Current (Note 6)		$V_{DD} = 5V$, V_{OUT} set to full scale, OUT shorted to GND, source current			65	mA
		$V_{DD} = 5V$, V_{OUT} set to 0V, OUT shorted to V_{DD} , sink current			65	
		$V_{DD} = 1.8V$, V_{OUT} set to full scale OUT shorted to GND, source current			14	
		$V_{DD} = 1.8V$, V_{OUT} set to 0V, OUT shorted to V_{DD} , sink current			14	

Dual, Ultra-Low-Power, 10-Bit, Voltage-Output DACs

ELECTRICAL CHARACTERISTICS (continued)

($V_{DD} = +1.8V$ to $+5.5V$, OUT_{-} unloaded, $T_A = T_{MIN}$ to T_{MAX} , unless otherwise noted. Typical values are at $T_A = +25^{\circ}C$.)

PARAMETER	SYMBOL	CONDITIONS		MIN	TYP	MAX	UNITS
DAC Power-Up Time		Coming out of shutdown (MAX5522/MAX5524)	$V_{DD} = 5V$		3		μs
			$V_{DD} = 1.8V$		3.8		
		Coming out of standby (MAX5523/MAX5525)	$V_{DD} = 1.8V$ to $5.5V$		0.4		
Output Power-Up Glitch		$C_L = 100pF$			10		mV
FB_ Input Current					10		pA
DIGITAL INPUTS (SCLK, DIN, \overline{CS})							
Input High Voltage	V_{IH}	$4.5V \leq V_{DD} \leq 5.5V$			2.4		V
		$2.7V < V_{DD} \leq 3.6V$			2.0		
		$1.8V \leq V_{DD} \leq 2.7V$			$0.7 \times V_{DD}$		
Input Low Voltage	V_{IL}	$4.5V \leq V_{DD} \leq 5.5V$				0.8	V
		$2.7V < V_{DD} \leq 3.6V$				0.6	
		$1.8V \leq V_{DD} \leq 2.7V$				$0.3 \times V_{DD}$	
Input Leakage Current	I_{IN}	(Note 9)			± 0.05	± 0.5	μA
Input Capacitance	C_{IN}				10		pF
DYNAMIC PERFORMANCE							
Voltage-Output Slew Rate	SR	Positive and negative (Note 10)			10		V/ms
Voltage-Output Settling Time		0.1 to 0.9 of full scale to within 0.5 LSB (Note 10)			660		μs
Output Noise Voltage		0.1Hz to 10Hz	$V_{DD} = 5V$		80		μV_{P-P}
			$V_{DD} = 1.8V$		55		
		10Hz to 10kHz	$V_{DD} = 5V$		620		
			$V_{DD} = 1.8V$		476		
POWER REQUIREMENTS							
Supply Voltage Range	V_{DD}			1.8		5.5	V
Supply Current (Note 9)	I_{DD}	MAX5523/MAX5525	$V_{DD} = 5V$		7.0	8.0	μA
			$V_{DD} = 3V$		6.4	8.0	
			$V_{DD} = 1.8V$		7.0	8.0	
		MAX5522/MAX5524	$V_{DD} = 5V$		3.8	5.0	
			$V_{DD} = 3V$		3.8	5.0	
			$V_{DD} = 1.8V$		4.7	6.0	
Standby Supply Current	I_{DDSD}	MAX5523/MAX5525 (Note 9)	$V_{DD} = 5V$		3.3	4.5	μA
			$V_{DD} = 3V$		2.8	4.0	
			$V_{DD} = 1.8V$		2.4	3.5	
Shutdown Supply Current	I_{DDPD}	(Note 9)			0.05	0.25	μA

Dual, Ultra-Low-Power, 10-Bit, Voltage-Output DACs

MAX5522-MAX5525

TIMING CHARACTERISTICS

($V_{DD} = +4.5V$ to $+5.5V$, $T_A = T_{MIN}$ to T_{MAX} , unless otherwise noted. Typical values are at $T_A = +25^\circ C$.)

PARAMETER	SYMBOL	CONDITIONS	MIN	TYP	MAX	UNITS
TIMING CHARACTERISTICS ($V_{DD} = 4.5V$ to $5.5V$)						
Serial Clock Frequency	f _{SCLK}		0		16.7	MHz
DIN to SCLK Rise Setup Time	t _{DS}		15			ns
DIN to SCLK Rise Hold Time	t _{DH}		0			ns
SCLK Pulse-Width High	t _{CH}		24			ns
SCLK Pulse-Width Low	t _{CL}		24			ns
\overline{CS} Pulse-Width High	t _{CSW}		100			ns
SCLK Rise to \overline{CS} Rise Hold Time	t _{CSH}		0			ns
\overline{CS} Fall to SCLK Rise Setup Time	t _{CSS}		20			ns
SCLK Fall to \overline{CS} Fall Setup	t _{CSO}		0			ns
\overline{CS} Rise to SCK Rise Hold Time	t _{CS1}		20			ns

TIMING CHARACTERISTICS

($V_{DD} = +1.8V$ to $+5.5V$, $T_A = T_{MIN}$ to T_{MAX} , unless otherwise noted. Typical values are at $T_A = +25^\circ C$.)

PARAMETER	SYMBOL	CONDITIONS	MIN	TYP	MAX	UNITS
TIMING CHARACTERISTICS ($V_{DD} = 1.8V$ to $5.5V$)						
Serial Clock Frequency	f _{SCLK}		0		10	MHz
DIN to SCLK Rise Setup Time	t _{DS}		24			ns
DIN to SCLK Rise Hold Time	t _{DH}		0			ns
SCLK Pulse-Width High	t _{CH}		40			ns
SCLK Pulse-Width Low	t _{CL}		40			ns
\overline{CS} Pulse-Width High	t _{CSW}		150			ns
SCLK Rise to \overline{CS} Rise Hold Time	t _{CSH}		0			ns
\overline{CS} Fall to SCLK Rise Setup Time	t _{CSS}		30			ns
SCLK Fall to \overline{CS} Fall Setup	t _{CSO}		0			ns
\overline{CS} Rise to SCK Rise Hold Time	t _{CS1}		30			ns

Note 1: Linearity is tested within codes 24 to 1020.

Note 2: Offset is tested at code 24.

Note 3: Gain is tested at code 1023. For the MAX5524/MAX5525, FB₋ is connected to its respective OUT₋.

Note 4: Guaranteed by design. Not production tested

Note 5: V_{DD} must be a minimum of 1.8V.

Note 6: Outputs can be shorted to V_{DD} or GND indefinitely, provided that package power dissipation is not exceeded.

Note 7: Optimal noise performance is at 2nF load capacitance.

Note 8: Thermal hysteresis is defined as the change in the initial $+25^\circ C$ output voltage after cycling the device from T_{MAX} to T_{MIN} .

Note 9: All digital inputs at V_{DD} or GND.

Note 10: Load = 10k Ω in parallel with 100pF, $V_{DD} = 5V$, $V_{REF} = 4.096V$ (MAX5522/MAX5524) or $V_{REF} = 3.9V$ (MAX5523/MAX5525).

Dual, Ultra-Low-Power, 10-Bit, Voltage-Output DACs

Typical Operating Characteristics

($V_{DD} = 5.0V$, $V_{REF} = 4.096V$ (MAX5522/MAX5524), $V_{REF} = 3.9V$ (MAX5523/MAX5525), $T_A = +25^\circ C$, unless otherwise noted.)

SUPPLY CURRENT vs. SUPPLY VOLTAGE (MAX5522/MAX5524)

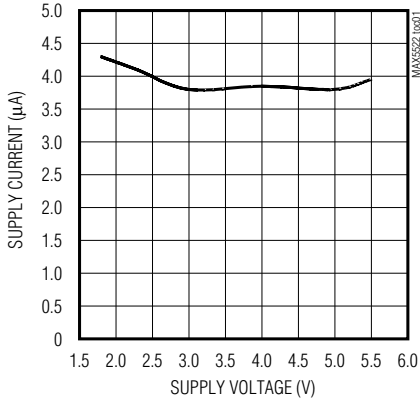

SUPPLY CURRENT vs. TEMPERATURE (MAX5522/MAX5524)

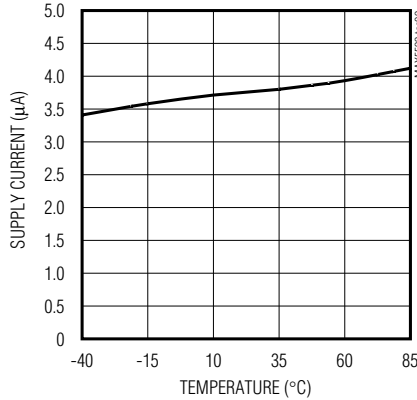

SUPPLY CURRENT vs. SUPPLY VOLTAGE (MAX5523/MAX5525)

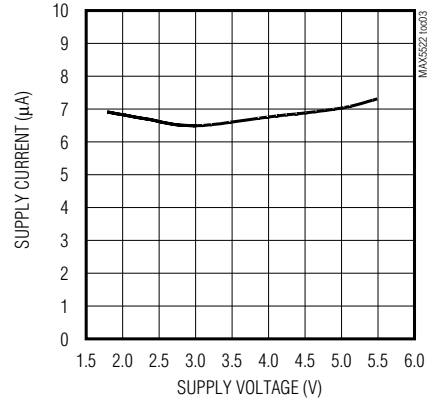

SUPPLY CURRENT vs. TEMPERATURE (MAX5523/MAX5525)

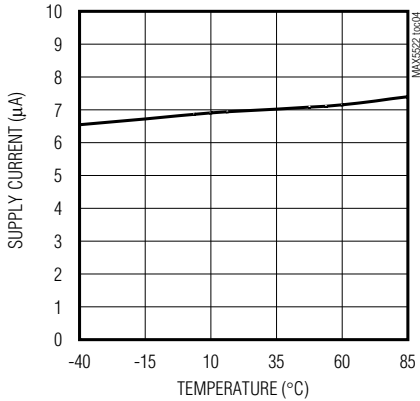

SHUTDOWN SUPPLY CURRENT vs. TEMPERATURE (MAX5522/MAX5524)

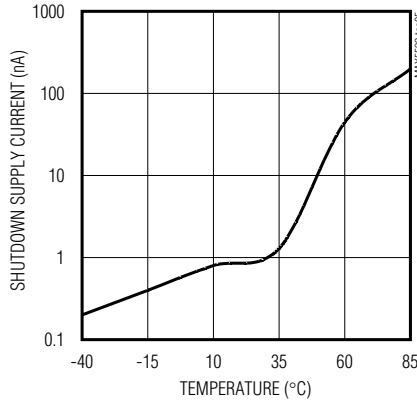

SHUTDOWN SUPPLY CURRENT vs. TEMPERATURE (MAX5523/MAX5525)

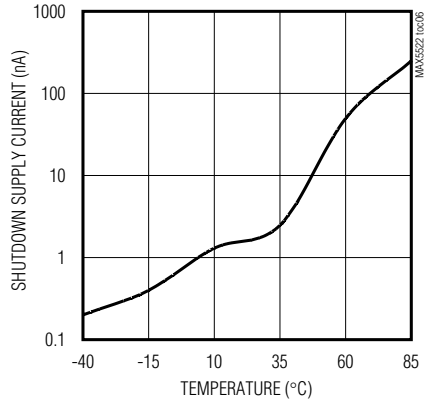

STANDBY SUPPLY CURRENT vs. TEMPERATURE (MAX5523/MAX5525)

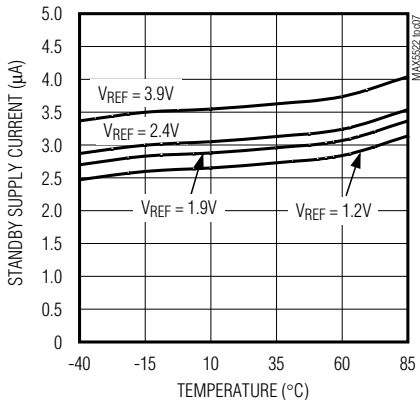

SUPPLY CURRENT vs. CLOCK FREQUENCY

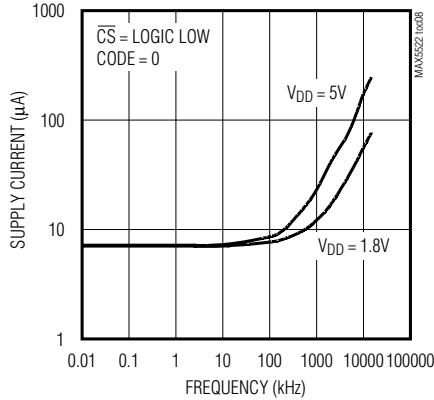

SUPPLY CURRENT vs. LOGIC INPUT VOLTAGE

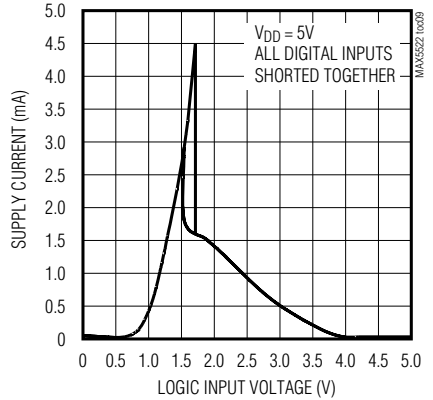

Dual, Ultra-Low-Power, 10-Bit, Voltage-Output DACs

Typical Operating Characteristics (continued)

($V_{DD} = 5.0V$, $V_{REF} = 4.096V$ (MAX5522/MAX5524), $V_{REF} = 3.9V$ (MAX5523/MAX54525), $T_A = +25^\circ C$, unless otherwise noted.)

MAX5522-MAX5525

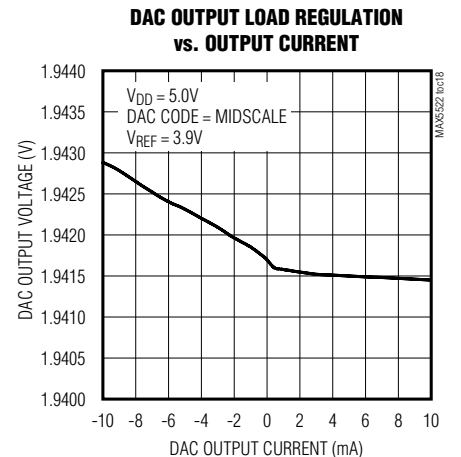
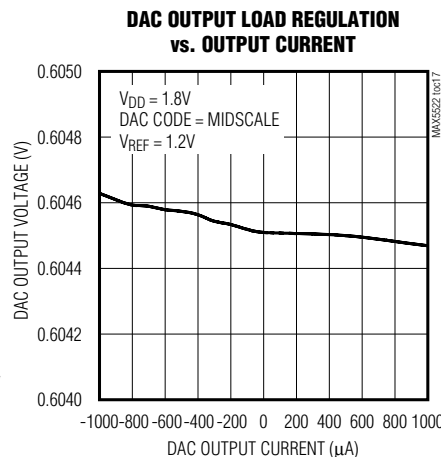
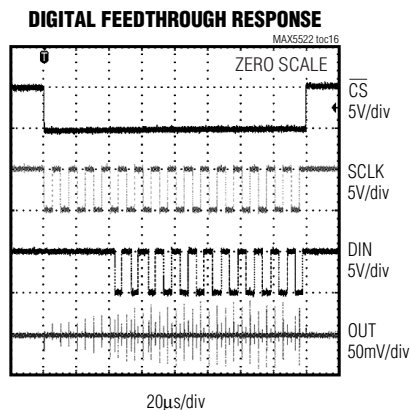
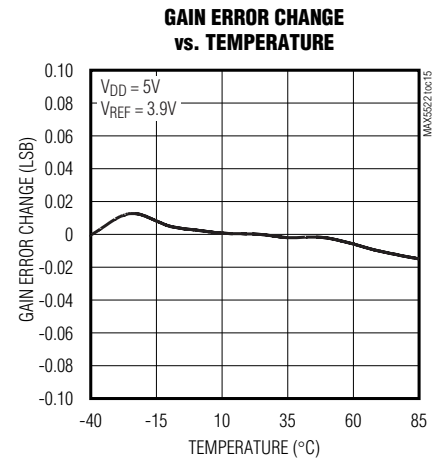
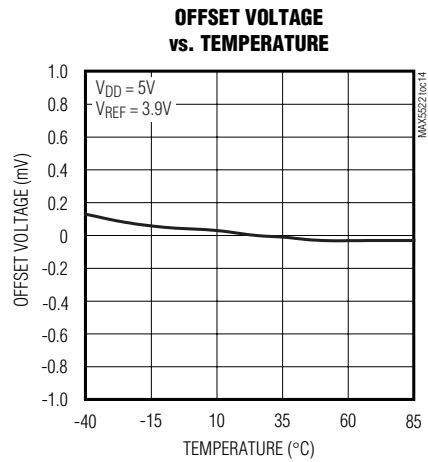
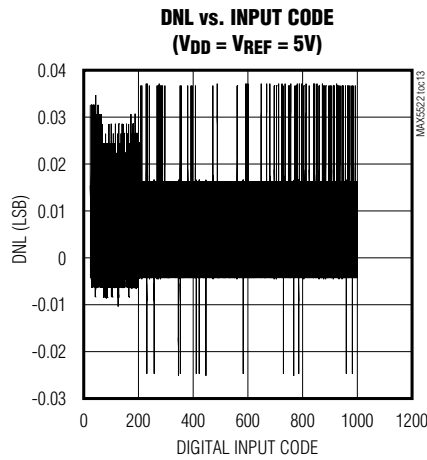
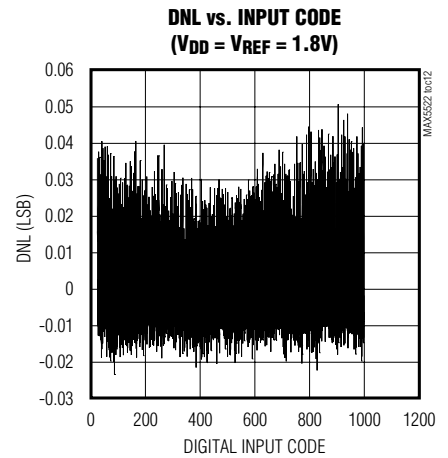
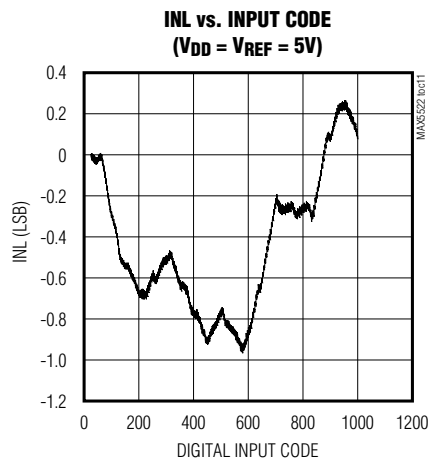
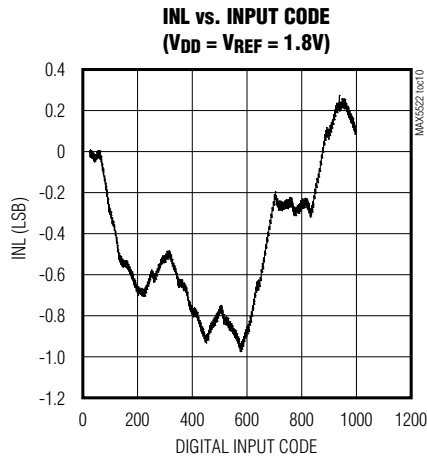

Dual, Ultra-Low-Power, 10-Bit, Voltage-Output DACs

Typical Operating Characteristics (continued)

($V_{DD} = 5.0V$, $V_{REF} = 4.096V$ (MAX5522/MAX5524), $V_{REF} = 3.9V$ (MAX5523/MAX54525), $T_A = +25^\circ C$, unless otherwise noted.)

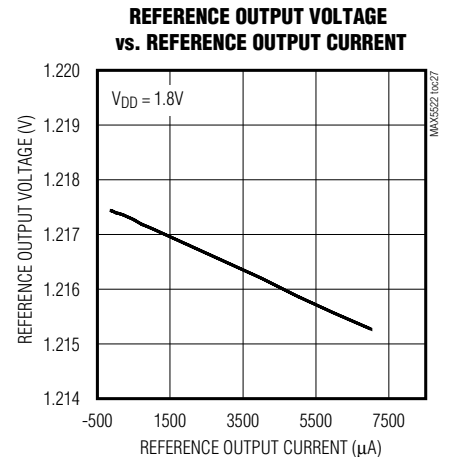
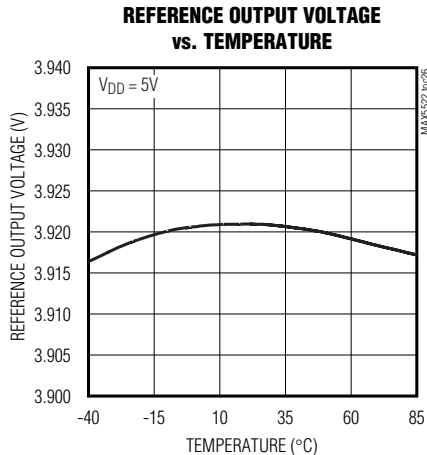
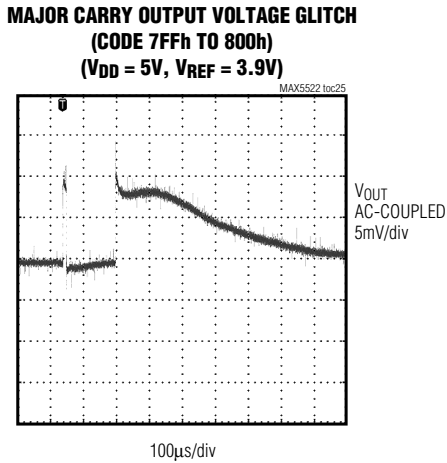
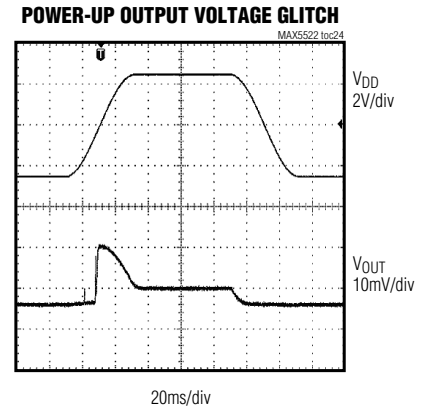
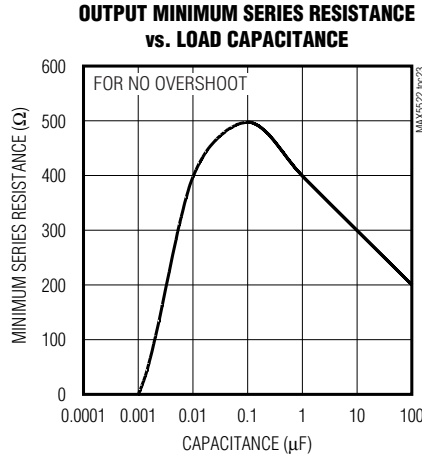
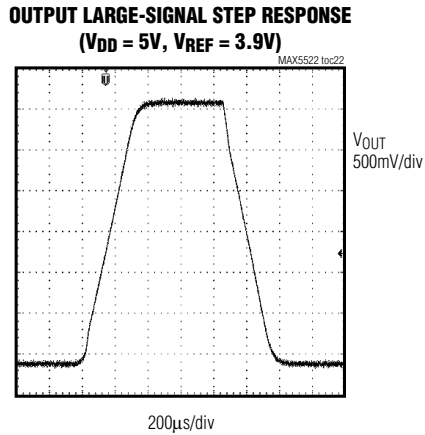
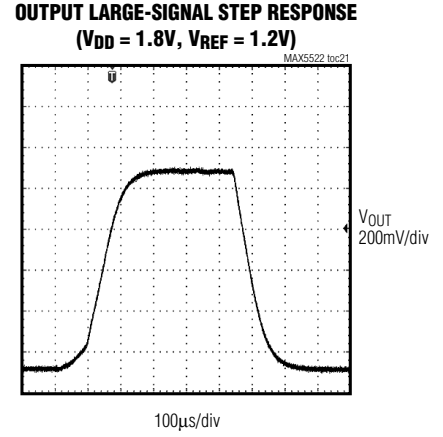
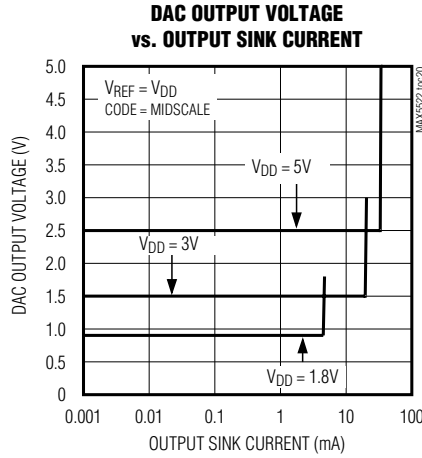
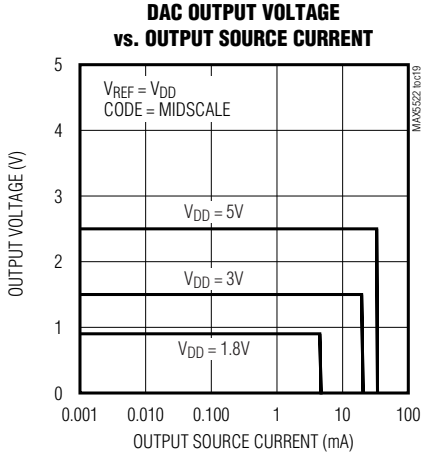

Dual, Ultra-Low-Power, 10-Bit, Voltage-Output DACs

Typical Operating Characteristics (continued)

($V_{DD} = 5.0V$, $V_{REF} = 4.096V$ (MAX5522/MAX5524), $V_{REF} = 3.9V$ (MAX5523/MAX54525), $T_A = +25^\circ C$, unless otherwise noted.)

MAX5522-MAX5525

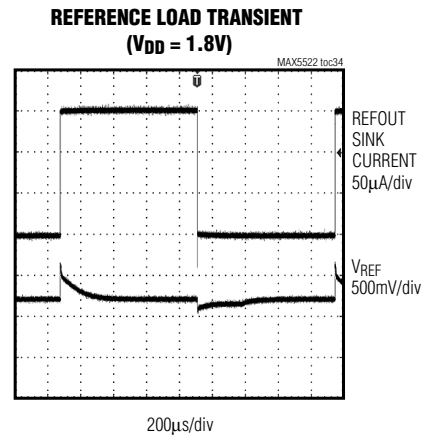
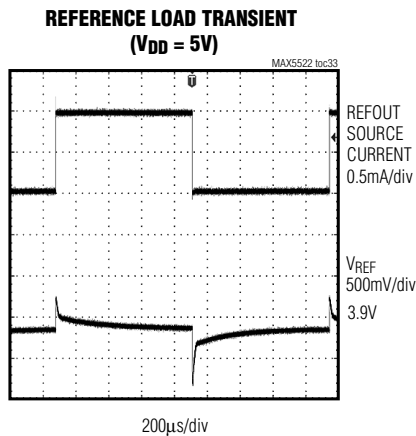
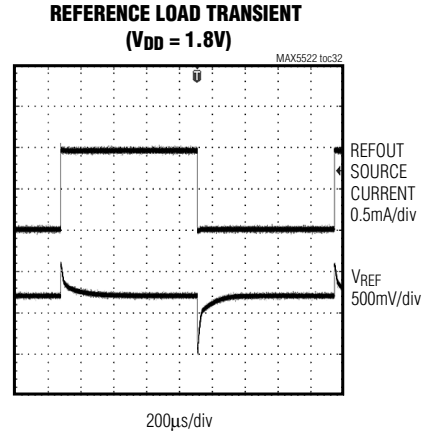
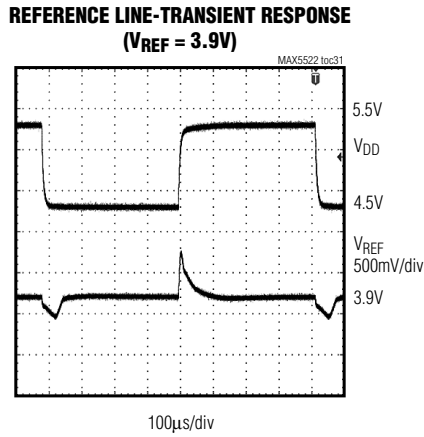
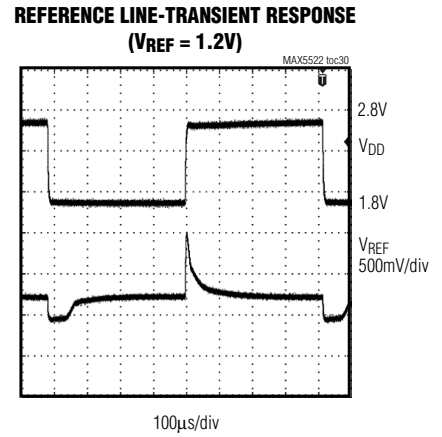
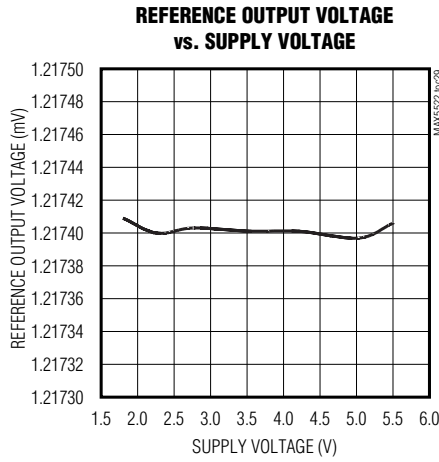
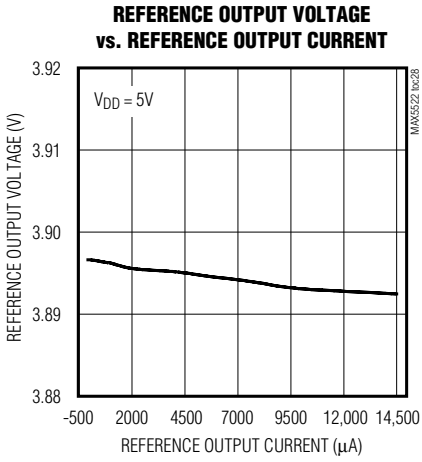

Dual, Ultra-Low-Power, 10-Bit, Voltage-Output DACs

Typical Operating Characteristics (continued)

($V_{DD} = 5.0V$, $V_{REF} = 4.096V$ (MAX5522/MAX5524), $V_{REF} = 3.9V$ (MAX5523/MAX54525), $T_A = +25^\circ C$, unless otherwise noted.)

REFERENCE LOAD TRANSIENT
($V_{DD} = 5V$)

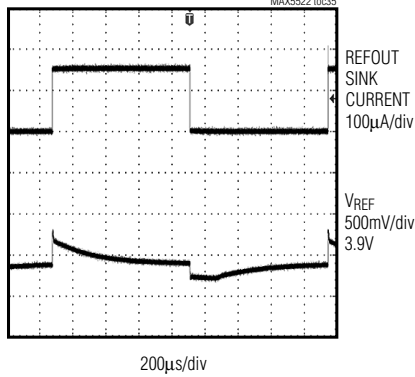

REFERENCE PSRR vs. FREQUENCY

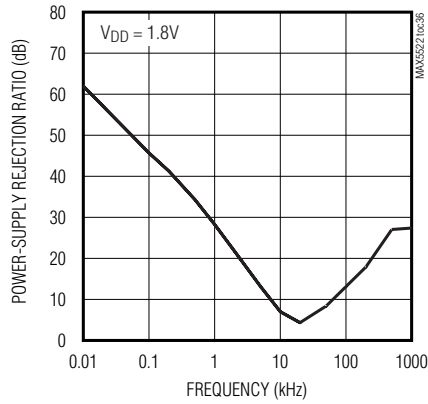

REFERENCE PSRR vs. FREQUENCY

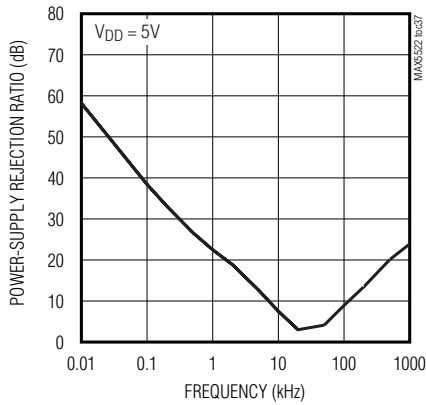

REFERENCE OUTPUT NOISE
(0.1Hz TO 10Hz) ($V_{DD} = 1.8V$, $V_{REF} = 1.2V$)

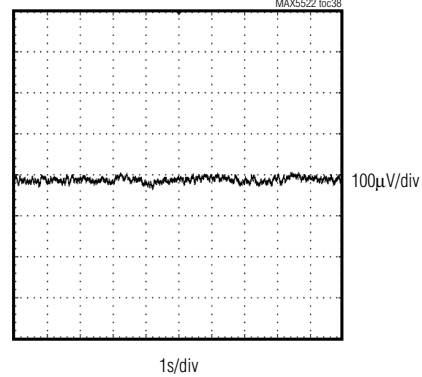

REFERENCE OUTPUT NOISE
(0.1Hz TO 10Hz) ($V_{DD} = 5V$, $V_{REF} = 3.9V$)

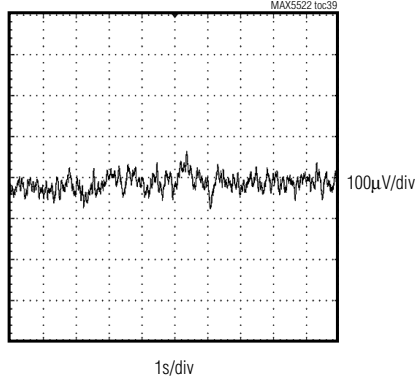

DAC-TO-DAC CROSSTALK

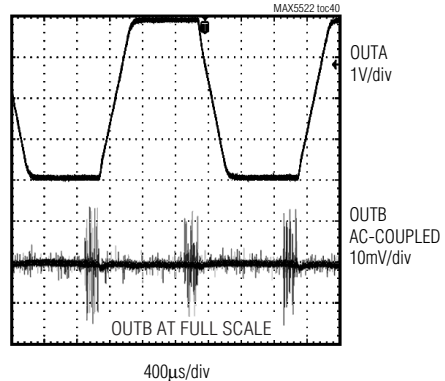

Dual, Ultra-Low-Power, 10-Bit, Voltage-Output DACs

Pin Description

PIN				NAME	FUNCTION
MAX5522	MAX5523	MAX5524	MAX5525		
1	1	1	1	\overline{CS}	Active-Low Digital Chip-Select Input
2	2	2	2	SCLK	Serial-Interface Clock Input
3	3	3	3	DIN	Serial-Interface Data Input
4	—	4	—	REFIN	Reference Input
—	4	—	4	REFOUT	Reference Output
—	—	5, 11	5, 11	N.C.	No Connection. Leave N.C. inputs unconnected (floating) or connected to GND.
—	—	6	6	FBB	Channel B Feedback Input
5	5	7	7	OUTB	Channel B Analog Voltage Output
6	6	8	8	VDD	Power Input. Connect VDD to a 1.8V to 5.5V power supply. Bypass VDD to GND with a 0.1 μ F capacitor.
7	7	9	9	GND	Ground
8	8	10	10	OUTA	Channel A Analog Voltage Output
—	—	12	12	FBA	Channel A Feedback Input
—	—	EP	EP	Exposed Paddle	Exposed Paddle. Connect EP to GND.

MAX5522-MAX5525

Functional Diagrams

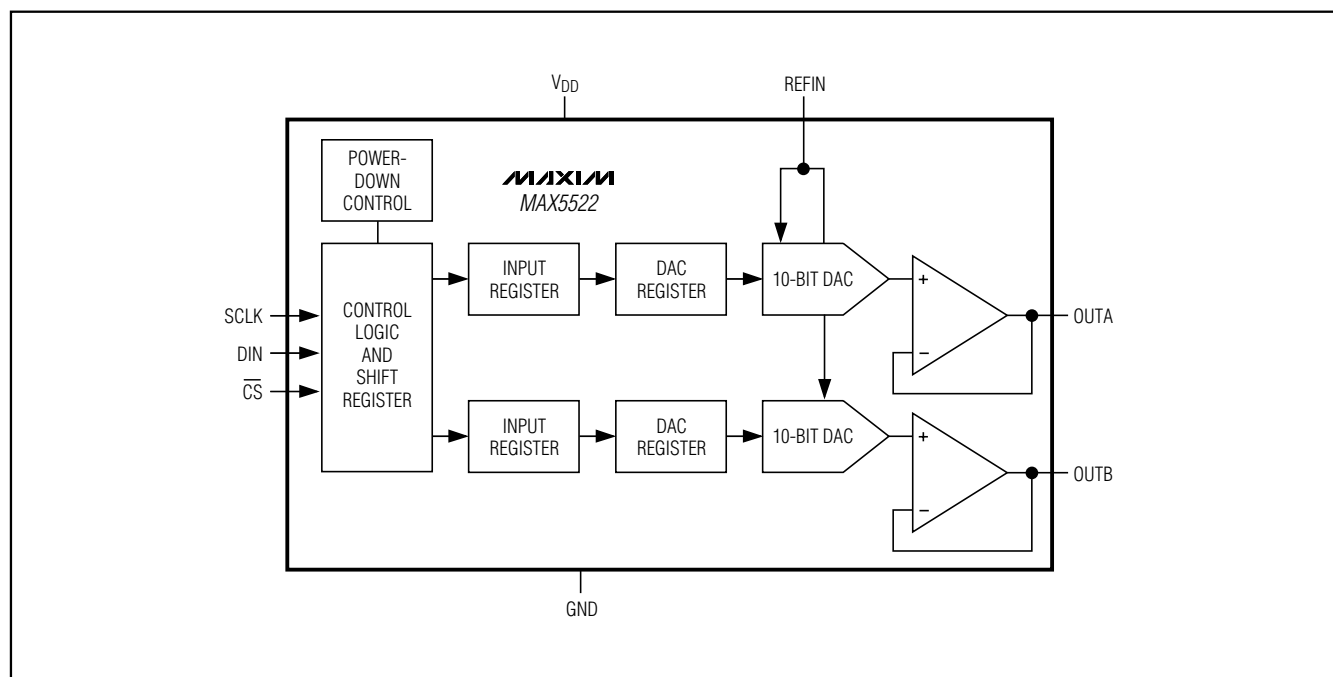

Dual, Ultra-Low-Power, 10-Bit, Voltage-Output DACs

Functional Diagrams (continued)

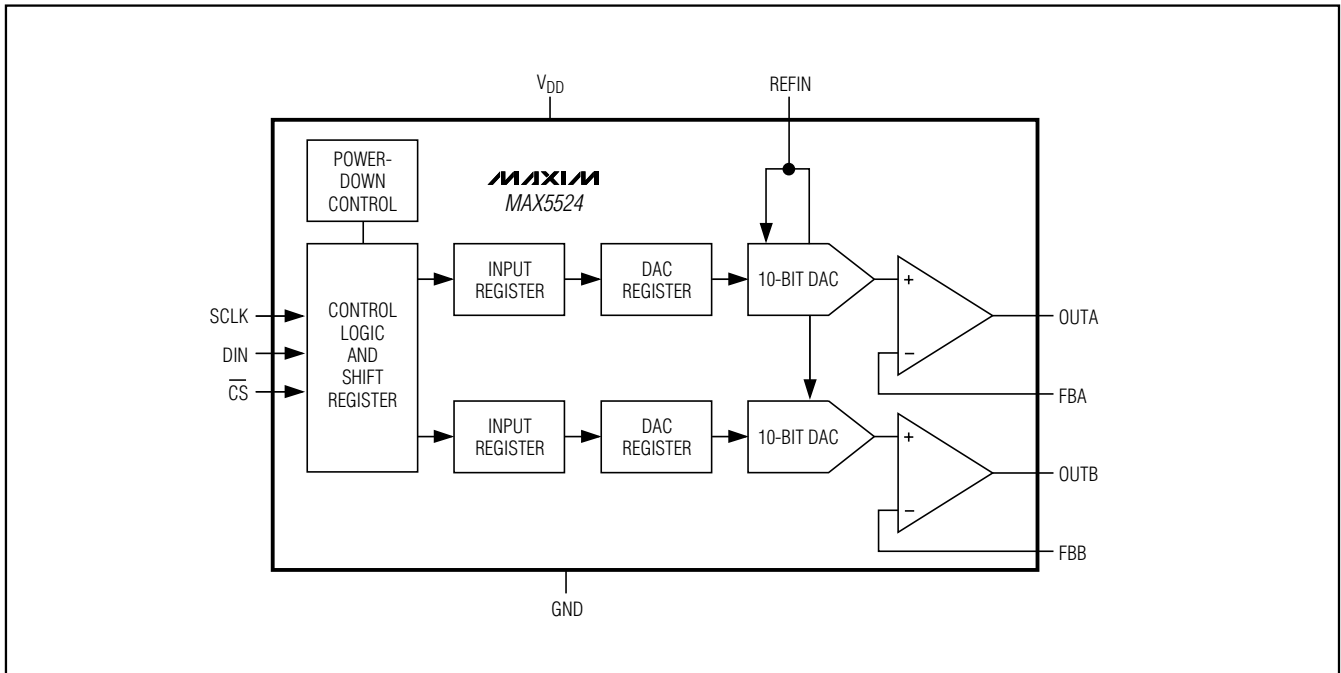
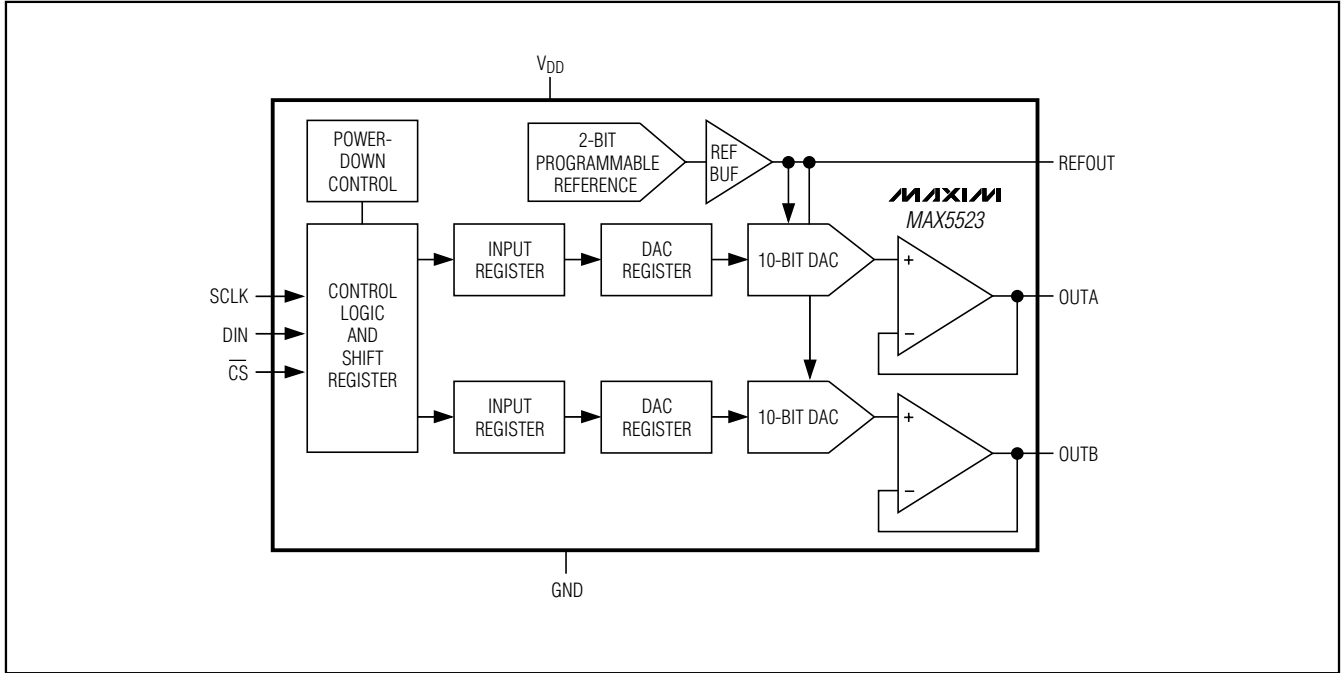

Dual, Ultra-Low-Power, 10-Bit, Voltage-Output DACs

Functional Diagrams (continued)

MAX5522-MAX5525

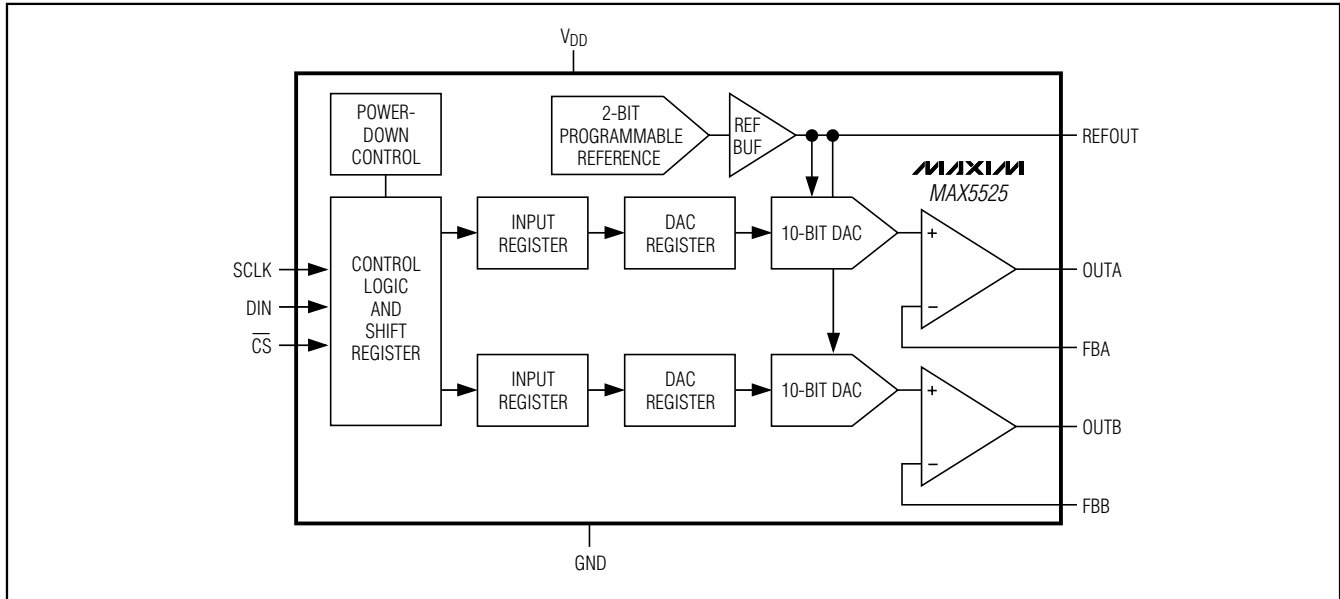

Detailed Description

The MAX5522–MAX5525 dual, 10-bit, ultra-low-power, voltage-output DACs offer rail-to-rail buffered voltage outputs. The DACs operate from a 1.8V to 5.5V supply and require only 5 μ A (max) supply current. These devices feature a shutdown mode that reduces overall current, including the reference input current, to just 0.18 μ A (max). The MAX5523/MAX5525 include an internal reference that saves additional board space and can source up to 8mA, making it functional as a system reference. The 16MHz, 3-wire serial interface is compatible with SPI, QSPI, and MICROWIRE protocols. When V_{DD} is applied, all DAC outputs are driven to zero scale with virtually no output glitch. The MAX5522/MAX5523 output buffers are configured in unity gain and come in μ MAX packages. The MAX5524/MAX5525 output buffers are configured in force sense allowing users to externally set voltage gains on the output (an output-amplifier inverting input is available). The MAX5524/MAX5525 come in 4mm x 4mm thin QFN packages.

Digital Interface

The MAX5522–MAX5525 use a 3-wire serial interface that is compatible with SPI/QSPI/MICROWIRE protocols (Figures 1 and 2).

The MAX5522–MAX5525 include a single, 16-bit, input shift register. Data loads into the shift register through the serial interface. \overline{CS} must remain low until all 16 bits are clocked in. The 16 bits consist of 4 control bits (C3–C0), 10 data bits (D9–D0) (Table 1), and 2 sub-bits (S1 and S0). D9–D0 are the DAC data bits and S1 and S0 are the sub-bits. The sub-bits must be set to zero for proper operation. Following the control bits, data loads MSB first, D9–D0. The control bits C3–C0 control the MAX5522–MAX5525, as outlined in Table 2.

Each DAC channel includes two registers: an input register and a DAC register. The input register holds input data. The DAC register contains the data updated to the DAC output.

The double-buffered register configuration allows any of the following:

- Loading the input registers without updating the DAC registers
- Updating the DAC registers from the input registers
- Updating all the input and DAC registers simultaneously

Dual, Ultra-Low-Power, 10-Bit, Voltage-Output DACs

Table 1. Serial Write Data Format

CONTROL				DATA BITS												
MSB																LSB
C3	C2	C1	C0	D9	D8	D7	D6	D5	D4	D3	D2	D1	D0	S1	S0	

Sub-bits S1 to S0 must be set to zero for proper operation.

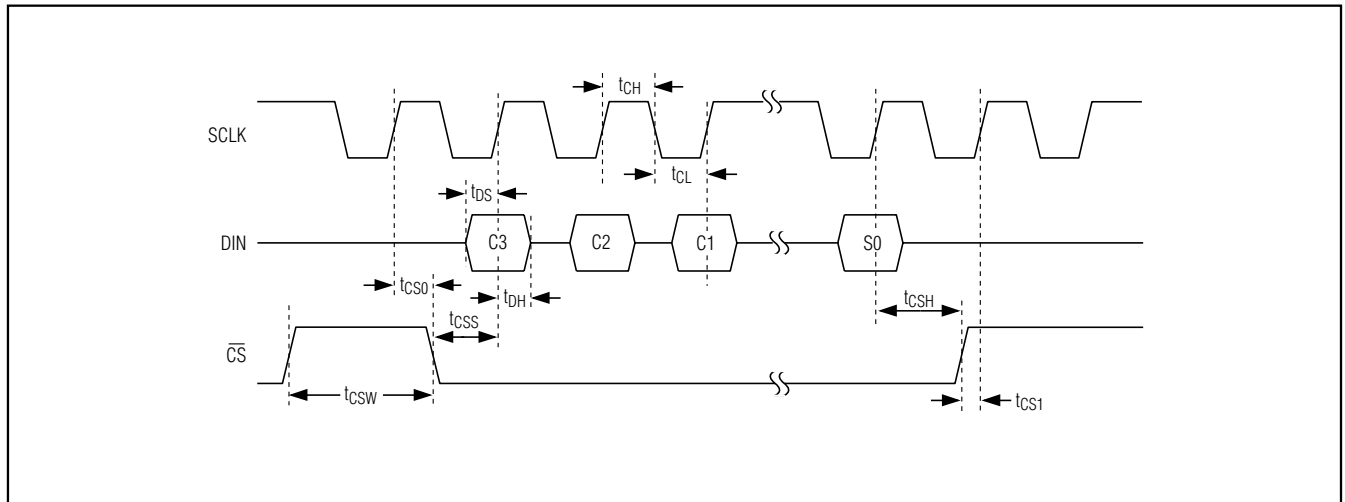

Figure 1. Timing Diagram

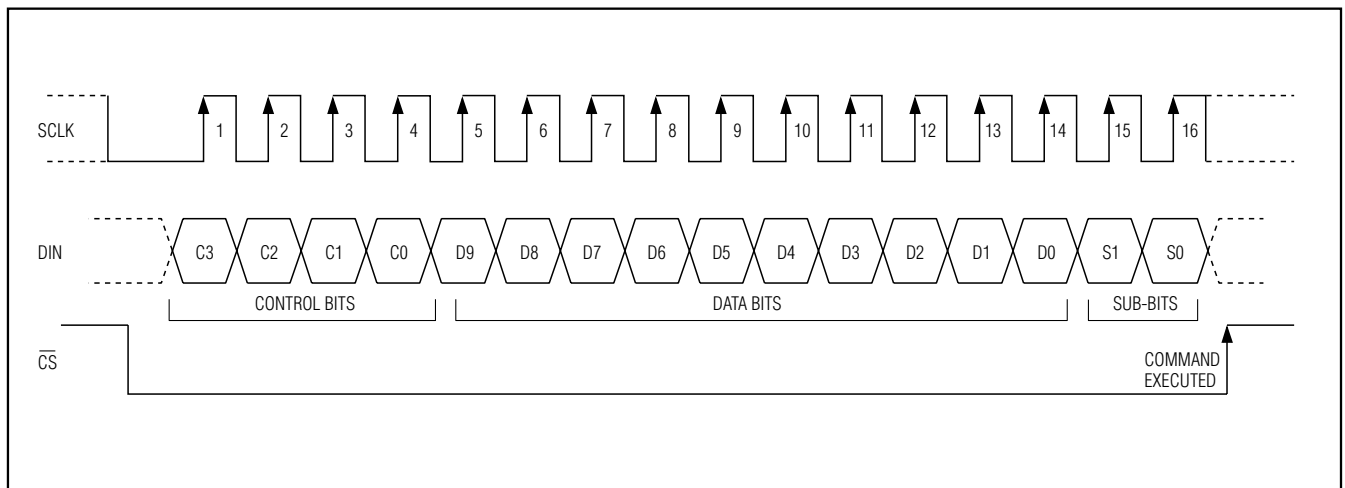

Figure 2. Register Loading Diagram

Dual, Ultra-Low-Power, 10-Bit, Voltage-Output DACs

MAX5522-MAX5525

Table 2. Serial-Interface Programming Commands

CONTROL BITS				INPUT DATA	SUB-BITS	FUNCTION
C3	C2	C1	C0	D9–D0	S1 AND S0	
0	0	0	0	XXXXXXXXXX	00	No operation; command is ignored.
0	0	0	1	10-bit data	00	Load input register A from shift register; DAC registers unchanged; DAC outputs unchanged.
0	0	1	0	10-bit data	00	Load input register B from shift register; DAC registers unchanged; DAC outputs unchanged.
0	0	1	1	—	—	Command reserved. Do not use.
0	1	0	0	—	—	Command reserved. Do not use.
0	1	0	1	—	—	Command reserved. Do not use.
0	1	1	0	—	—	Command reserved. Do not use.
0	1	1	1	—	—	Command reserved. Do not use.
1	0	0	0	10-bit data	00	Load DAC registers A and B from respective input registers; DAC outputs A and B updated; MAX5523/MAX5525 enter normal operation if in standby or shutdown; MAX5522/MAX5524 enter normal operation if in shutdown.
1	0	0	1	10-bit data	00	Load input register A and DAC register A from shift register; DAC output A updated; Load DAC register B from input register B; DAC output B updated; MAX5523/MAX5525 enter normal operation if in standby or shutdown; MAX5522/MAX5524 enter normal operation if in shutdown.
1	0	1	0	10-bit data	00	Load input register B and DAC register B from shift register; DAC output B updated; Load DAC register A from input register A; DAC output A updated; MAX5523/MAX5525 enter normal operation if in standby or shutdown; MAX5522/MAX5524 enter normal operation if in shutdown.
1	0	1	1	—	—	Command reserved. Do not use.
1	1	0	0	D9, D8, XXXXXXXXXX	00	MAX5523/MAX5525 enter standby*, MAX5522/MAX5524 enter shutdown. For the MAX5523/MAX5525, D9 and D8 configure the internal reference voltage (Table 3).
1	1	0	1	D9, D8, XXXXXXXXXX	00	MAX5522–MAX5525 enter normal operation; DAC outputs reflect existing contents of DAC registers. For the MAX5523/MAX5525, D9 and D8 configure the internal reference voltage (Table 3).
1	1	1	0	D9, D8, XXXXXXXXXX	00	MAX5522–MAX5525 enter shutdown; DAC outputs set to high impedance. For the MAX5523/MAX5525, D9 and D8 configure the internal reference voltage (Table 3).
1	1	1	1	10-bit data	00	Load input registers A and B and DAC registers A and B from shift register; DAC outputs A and B updated; MAX5523/MAX5525 enter normal operation if in standby or shutdown; MAX5522/MAX5524 enter normal operation if in shutdown.

X = Don't care.

*Standby mode can be entered from normal operation only. It is not possible to enter standby mode from shutdown.

Dual, Ultra-Low-Power, 10-Bit, Voltage-Output DACs

Power Modes

The MAX5522–MAX5525 feature two power modes to conserve power during idle periods. In normal operation, the device is fully operational. In shutdown mode, the device is completely powered down, including the internal voltage reference in the MAX5523/MAX5525. The MAX5523/MAX5525 also offer a standby mode in which all circuitry is powered down except the internal voltage reference. Standby mode keeps the reference powered up while the remaining circuitry is shut down, allowing it to be used as a system reference. It also helps reduce the wake-up delay by not requiring the reference to power up when returning to normal operation.

Shutdown Mode

The MAX5522–MAX5525 feature a software-programmable shutdown mode that reduces the supply current and the interface input-current to 0.18μA (max). Writing an input control word with control bits C[3:0] = 1110 (Table 2) places the device in shutdown mode. In shutdown, the MAX5522/MAX5524 reference input and DAC output buffers go high impedance. Placing the MAX5523/MAX5525 into shutdown turns off the internal reference and the DAC output buffers go high impedance. The serial interface still remains active for all devices.

Table 2 shows several commands that bring the MAX5522–MAX5525 back to normal operation. The power-up time from shutdown is required before the DAC outputs are valid.

Note: For the MAX5523/MAX5525, standby mode cannot be entered directly from shutdown mode. The device must be brought into normal operation first before entering standby mode.

Standby Mode (MAX5523/MAX5525 Only)

The MAX5523/MAX5525 feature a software-programmable standby mode that reduces the typical supply current to 3μA (max). Standby mode powers down all circuitry except the internal voltage reference. Place the device in standby mode by writing an input control word with control bits C[3:0] = 1100 (Table 2). The internal reference and serial interface remain active while the DAC output buffers go high impedance.

For the MAX5523/MAX5525, standby mode cannot be entered directly from shutdown mode. The device must be brought into normal operation first before entering standby mode. To enter standby from shutdown, issue the command to return to normal operation followed immediately by the command to go into standby.

Table 2 shows several commands that bring the MAX5523/MAX5525 back to normal operation. When transitioning from standby mode to normal operation, only the DAC power-up time is required before the DAC outputs are valid.

Reference Input

The MAX5522/MAX5524 accept a reference with a voltage range extending from 0 to V_{DD}. The output voltage (V_{OUT}) is represented by a digitally programmable voltage source as:

$$V_{OUT} = (V_{REF} \times N / 256) \times \text{gain}$$

where N is the numeric value of the DAC's binary input code (0 to 1023), V_{REF} is the reference voltage, gain is the externally set voltage gain for the MAX5524, and gain is one for the MAX5522.

In shutdown mode, the reference input enters a high-impedance state with an input impedance of 2.5GΩ (typ).

Reference Output

The MAX5523/MAX5525 internal voltage reference is software configurable to one of four voltages. Upon power-up, the default reference voltage is 1.214V. Configure the reference voltage using D8 and D9 data bits (Table 3) when the control bits are as follows C[3:0] = 1100, 1101, or 1110 (Table 2). V_{DD} must be kept at a minimum of 200mV above V_{REF} for proper operation.

Table 3. Reference Output Voltage Programming

D9	D8	REFERENCE VOLTAGE (V)
0	0	1.214
0	1	1.940
1	0	2.425
1	1	3.885

Dual, Ultra-Low-Power, 10-Bit, Voltage-Output DACs

MAX5522-MAX5525

Applications Information

1-Cell and 2-Cell Circuits

See Figure 3 for an illustration of how to power the MAX5522-MAX5525 with either one lithium-ion battery or two alkaline batteries. The low current consumption of the devices make the MAX5522-MAX5525 ideal for battery-powered applications.

Programmable Current Source

See the circuit in Figure 4 for an illustration of how to configure the MAX5524/MAX5525 as a programmable current source for driving an LED. The MAX5524/MAX5525 drive a standard NPN transistor to program the current source. The current source (I_{LED}) is defined in the equation in Figure 4.

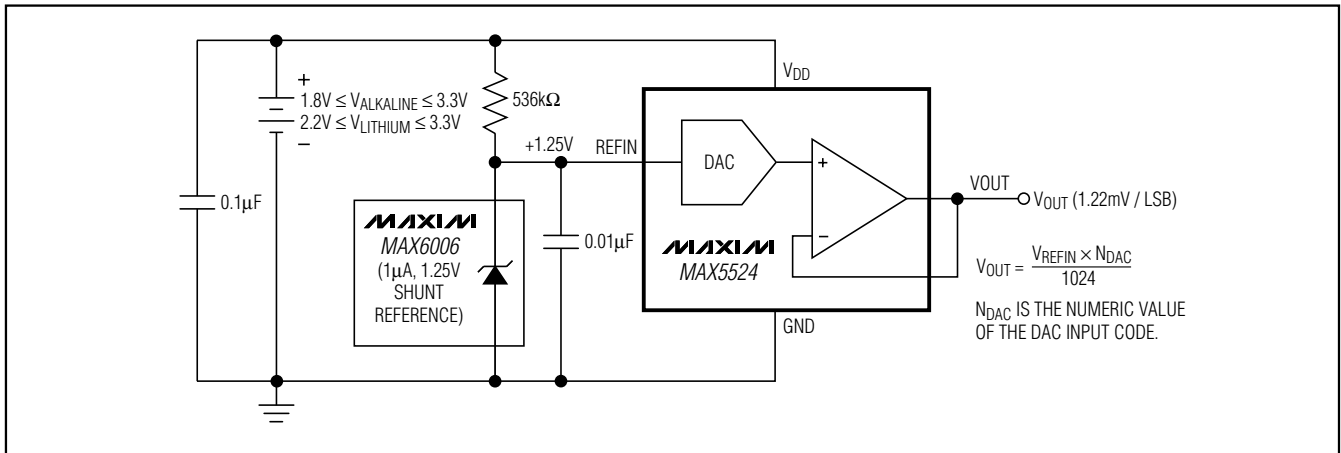

Figure 3. Portable Application Using Two Alkaline Cells or One Lithium Coin Cell

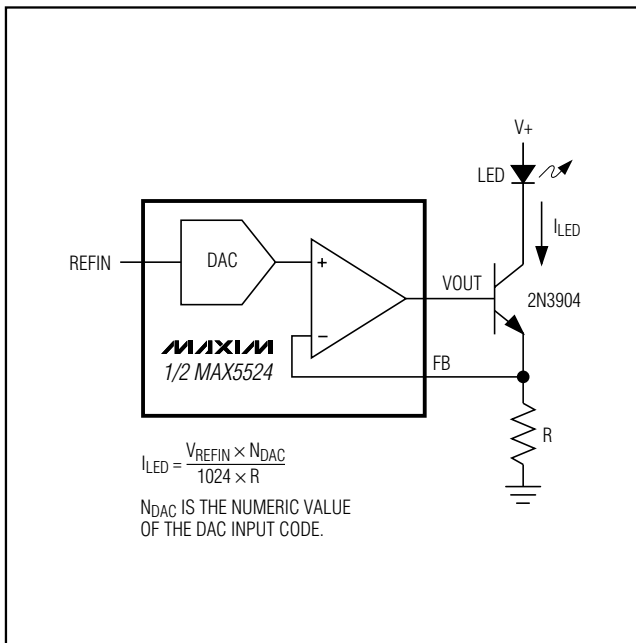

Figure 4. Programmable Current Source Driving an LED

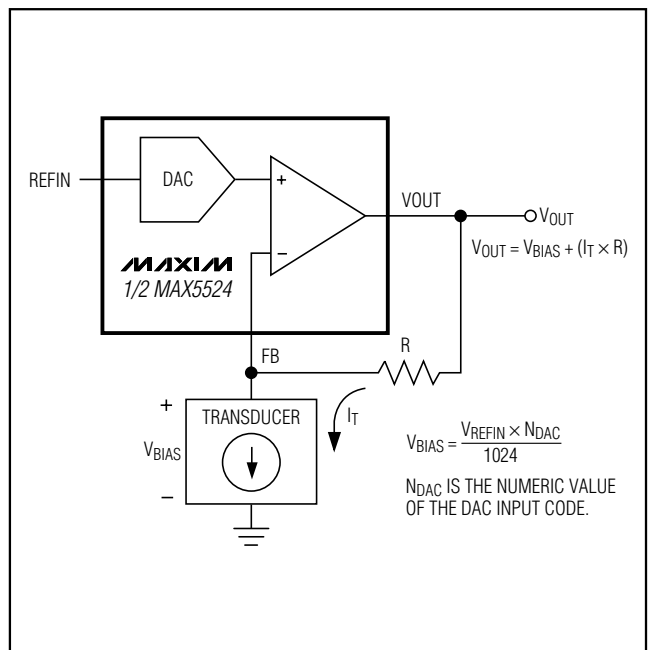

Figure 5. Transimpedance Configuration for a Voltage-Biased Current-Output Transducer

Dual, Ultra-Low-Power, 10-Bit, Voltage-Output DACs

Voltage Biasing a Current-Output Transducer

See the circuit in Figure 5 for an illustration of how to configure the MAX5524/MAX5525 to bias a current-output transducer. In Figure 5, the output voltage of the MAX5524/MAX5525 is a function of the voltage drop across the transducer added to the voltage drop across the feedback resistor R.

Unipolar Output

Figure 6 shows the MAX5524 in a unipolar output configuration with unity gain. Table 4 lists the unipolar output codes.

Bipolar Output

The MAX5524 output can be configured for bipolar operation as shown in Figure 7. The output voltage is given by the following equation:

$$V_{OUT_} = V_{REFIN} \times [(N_A - 512) / 512]$$

where N_A represents the decimal value of the DAC's binary input code. Table 5 shows the digital codes (offset binary) and the corresponding output voltage for the circuit in Figure 7.

Configurable Output Gain

The MAX5524/MAX5525 have force-sense outputs, which provide a connection directly to the inverting terminal of the output op amp, yielding the most flexibility. The advantage of the force-sense output is that specific gains can be set externally for a given application. The gain error for the MAX5524/MAX5525 is specified in a unity-gain configuration (op-amp output and inverting terminals connected), and additional gain error results from external resistor tolerances. Another advantage of the force-sense DAC is that it allows many useful circuits to be created with only a few simple external components.

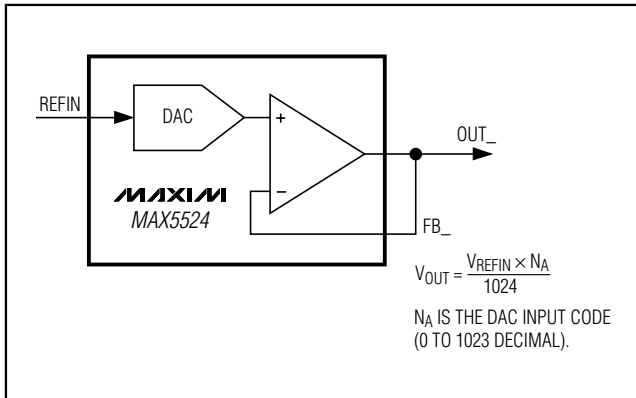

Figure 6. Unipolar Output Circuit

An example of a custom fixed gain using the MAX5524/MAX5525 force-sense output is shown in Figure 8. In this example, R1 and R2 set the gain for V_{OUTA} .

$$V_{OUTA} = [(V_{REFIN} \times N_A) / 1024] \times [1 + (R2 / R1)]$$

where N_A represents the numeric value of the DAC input code.

Self-Biased Two-Electrode Potentiostat Application

See the circuit in Figure 10 for an illustration of how to use the MAX5525 to bias a two-electrode potentiostat on the input of an ADC.

Power Supply and Bypassing Considerations

Bypass the power supply with a 4.7 μ F capacitor in parallel with a 0.1 μ F capacitor to GND. Minimize lengths to reduce lead inductance. If noise becomes an issue, use shielding and/or ferrite beads to increase isolation. For the thin QFN package, connect the exposed pad to ground.

Table 4. Unipolar Code Table (Gain = +1)

DAC CONTENTS			ANALOG OUTPUT
MSB	LSB		
1111	1111	1100	+V _{REF} (1023/1024)
1000	0000	0100	+V _{REF} (513/1024)
1000	0000	0000	+V _{REF} (512/1024) = +V _{REF} /2
0111	1111	1100	+V _{REF} (511/1024)
0000	0000	0100	+V _{REF} (1/1024)
0000	0000	0000	0V

Table 5. Bipolar Code Table (Gain = +1)

DAC CONTENTS			ANALOG OUTPUT
MSB	LSB		
1111	1111	1100	+V _{REF} (511/512)
1000	0000	0100	+V _{REF} (1/512)
1000	0000	0000	0V
0111	1111	1100	-V _{REF} (1/512)
0000	0000	0100	-V _{REF} (511/512)
0000	0000	0000	-V _{REF} (512/512) = -V _{REF}

Dual, Ultra-Low-Power, 10-Bit, Voltage-Output DACs

MAX5522-MAX5525

Layout Considerations

Digital and AC transient signals coupling to GND can create noise at the output. Use proper grounding techniques, such as a multilayer board with a low-inductance ground plane. Wire-wrapped boards and sockets are not recommended. For optimum system performance, use printed circuit (PC) boards. Good PC board ground layout minimizes crosstalk between DAC outputs, reference inputs, and digital inputs. Reduce crosstalk by keeping analog lines away from digital lines.

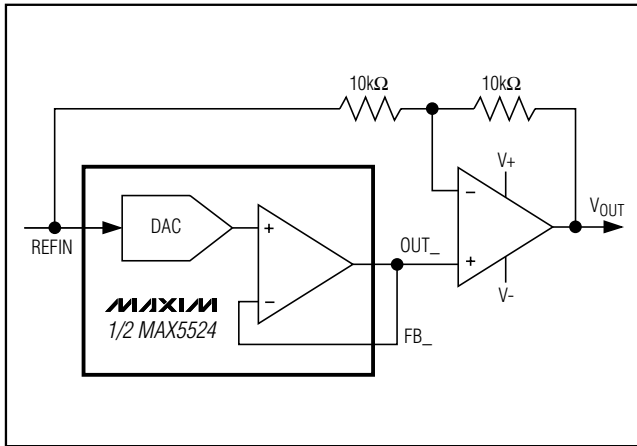

Figure 7. Bipolar Output Circuit

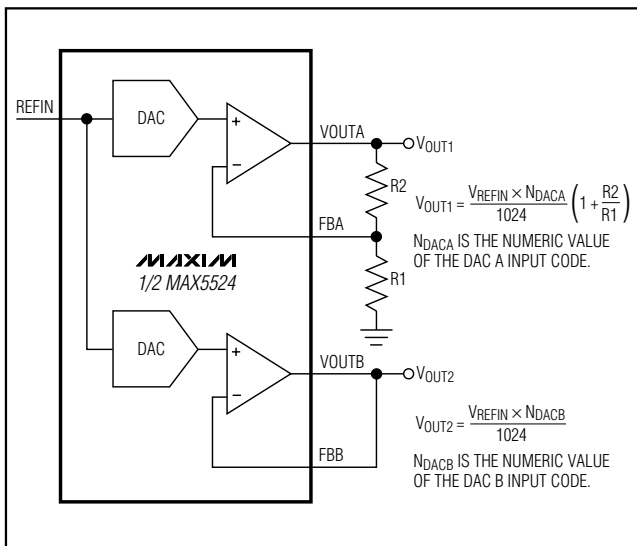

Figure 8. Separate Force-Sense Outputs Create Unity and Greater-than-Unity DAC Gains Using the Same Reference

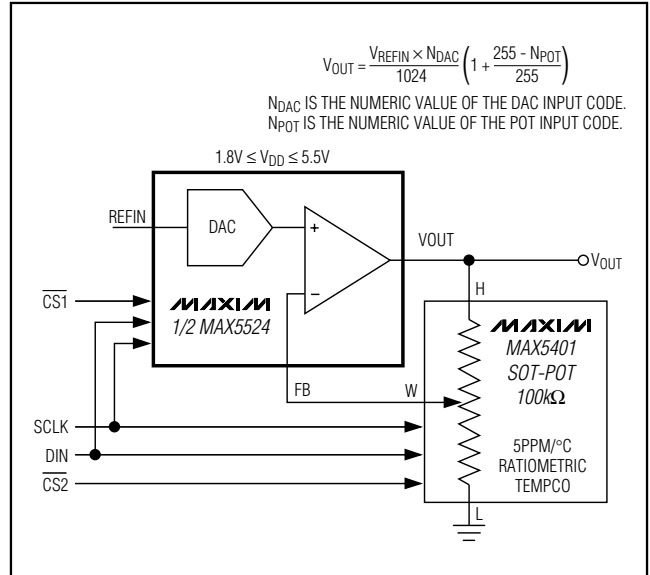

Figure 9. Software-Configurable Output Gain

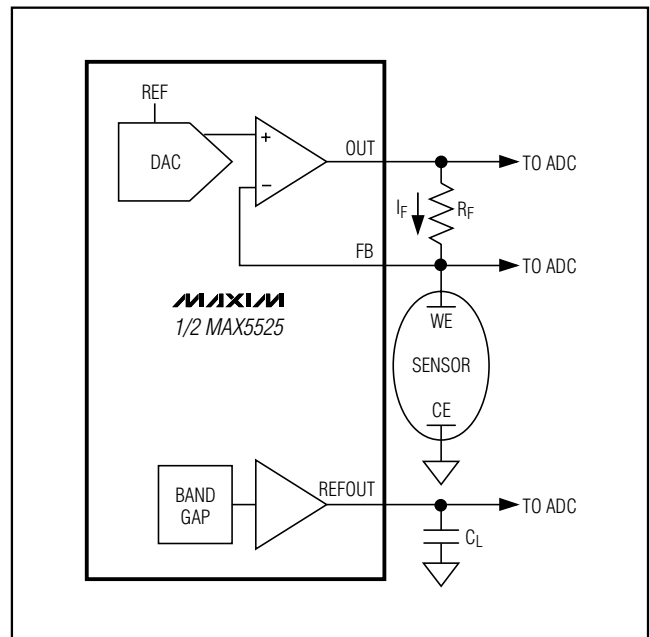

Figure 10. Self-Biased Two-Electrode Potentiostat Application

Dual, Ultra-Low-Power, 10-Bit, Voltage-Output DACs

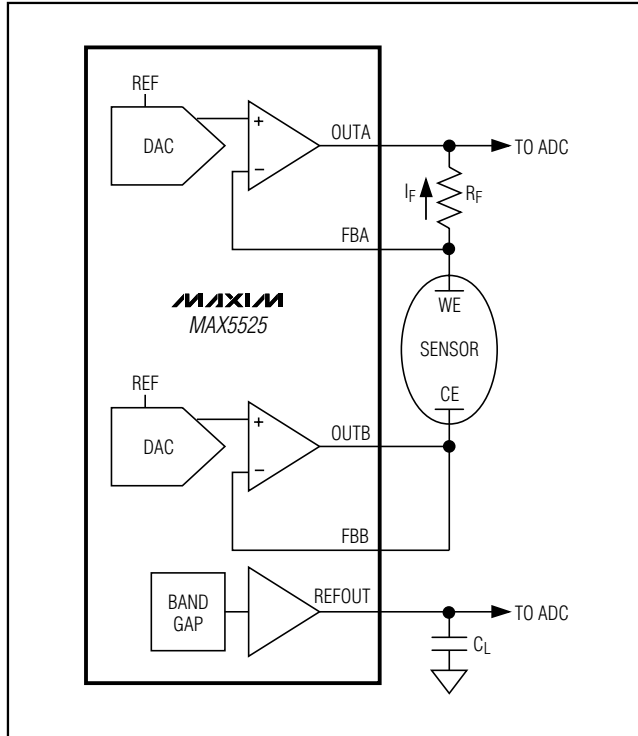
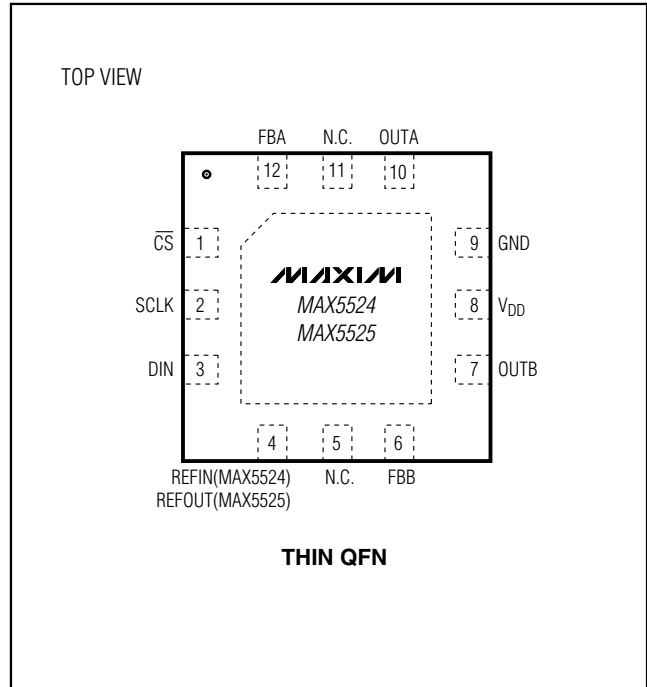

Figure 11. Driven Two-Electrode Potentiostat Application

Pin Configurations (continued)



Chip Information

TRANSISTOR COUNT: 10,688
 PROCESS: BiCMOS

Dual, Ultra-Low-Power, 10-Bit, Voltage-Output DACs

Package Information

(The package drawing(s) in this data sheet may not reflect the most current specifications. For the latest package outline information, go to www.maxim-ic.com/packages.)

MAX5522-MAX5525

24L QFN THINLEPS

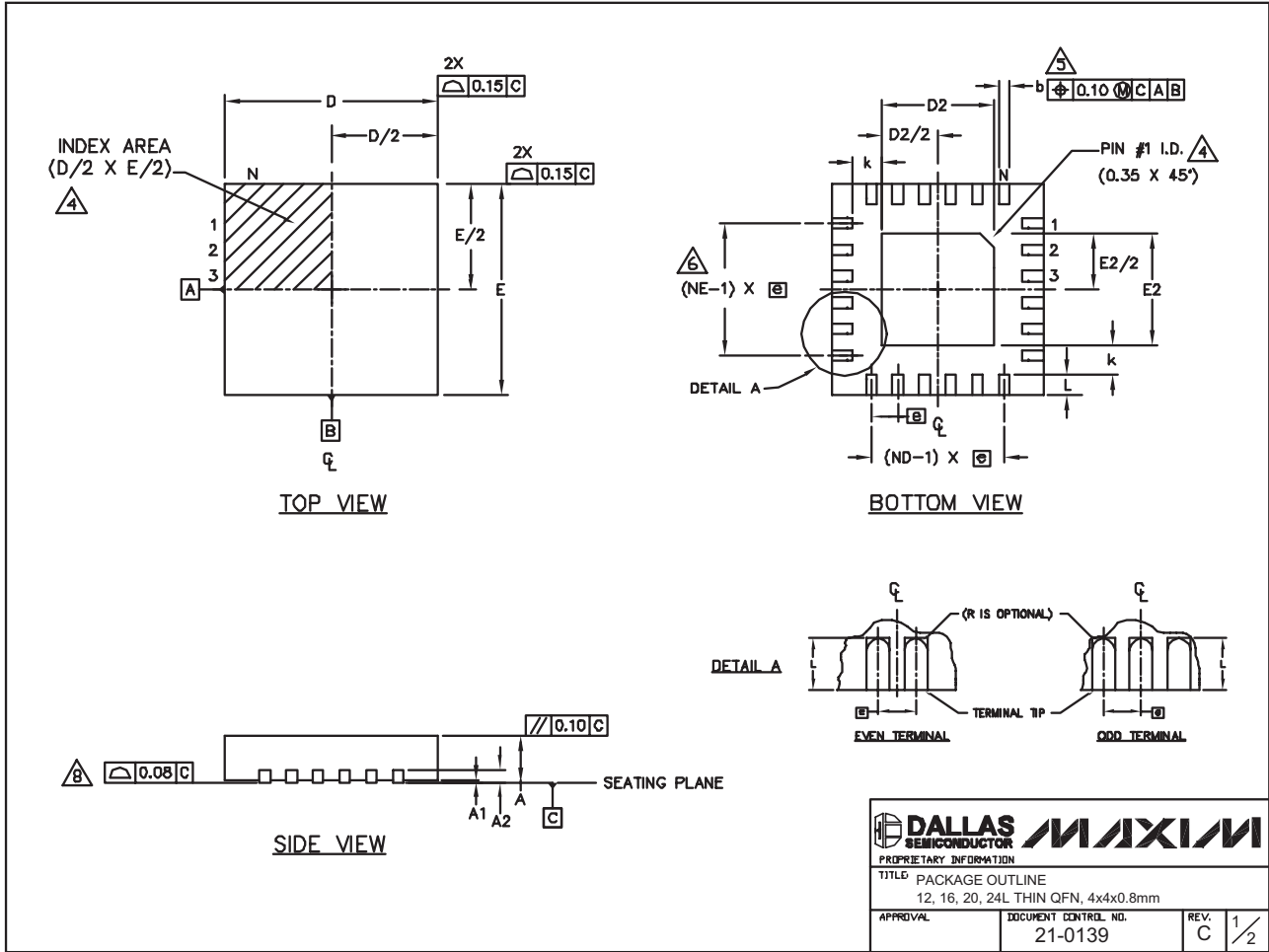

Dual, Ultra-Low-Power, 10-Bit, Voltage-Output DACs

Package Information (continued)

(The package drawing(s) in this data sheet may not reflect the most current specifications. For the latest package outline information, go to www.maxim-ic.com/packages.)

COMMON DIMENSIONS												
PKG REF.	12L 4x4			16L 4x4			20L 4x4			24L 4x4		
	MIN.	NOM.	MAX.	MIN.	NOM.	MAX.	MIN.	NOM.	MAX.	MIN.	NOM.	MAX.
A	0.70	0.75	0.80	0.70	0.75	0.80	0.70	0.75	0.80	0.70	0.75	0.80
A1	0.0	0.02	0.05	0.0	0.02	0.05	0.0	0.02	0.05	0.0	0.02	0.05
A2	0.20 REF			0.20 REF			0.20 REF			0.20 REF		
b	0.25	0.30	0.35	0.25	0.30	0.35	0.20	0.25	0.30	0.18	0.23	0.30
D	3.90	4.00	4.10	3.90	4.00	4.10	3.90	4.00	4.10	3.90	4.00	4.10
E	3.90	4.00	4.10	3.90	4.00	4.10	3.90	4.00	4.10	3.90	4.00	4.10
e	0.80 BSC.			0.65 BSC.			0.50 BSC.			0.50 BSC.		
k	0.25	-	-	0.25	-	-	0.25	-	-	0.25	-	-
L	0.45	0.55	0.65	0.45	0.55	0.65	0.45	0.55	0.65	0.30	0.40	0.50
N	12			16			20			24		
ND	3			4			5			6		
NE	3			4			5			6		
JeDEC Vgr.	WGGB			WGGC			WGGD-1			WGGD-2		

EXPOSED PAD VARIATIONS							
PKG. CODES	D2			E2			DOWN BONDS ALLOWED
	MIN.	NOM.	MAX.	MIN.	NOM.	MAX.	
T1244-2	1.95	2.10	2.25	1.95	2.10	2.25	NO
T1244-3	1.95	2.10	2.25	1.95	2.10	2.25	YES
T1244-4	1.95	2.10	2.25	1.95	2.10	2.25	NO
T1644-2	1.95	2.10	2.25	1.95	2.10	2.25	NO
T1644-3	1.95	2.10	2.25	1.95	2.10	2.25	YES
T1644-4	1.95	2.10	2.25	1.95	2.10	2.25	NO
T2044-1	1.95	2.10	2.25	1.95	2.10	2.25	NO
T2044-2	1.95	2.10	2.25	1.95	2.10	2.25	YES
T2044-3	1.95	2.10	2.25	1.95	2.10	2.25	NO
T2444-1	2.45	2.60	2.63	2.45	2.60	2.63	NO
T2444-2	1.95	2.10	2.25	1.95	2.10	2.25	YES
T2444-3	2.45	2.60	2.63	2.45	2.60	2.63	YES
T2444-4	2.45	2.60	2.63	2.45	2.60	2.63	NO

NOTES:

- DIMENSIONING & TOLERANCING CONFORM TO ASME Y14.5M-1994.
- ALL DIMENSIONS ARE IN MILLIMETERS. ANGLES ARE IN DEGREES.
- N IS THE TOTAL NUMBER OF TERMINALS.
- THE TERMINAL #1 IDENTIFIER AND TERMINAL NUMBERING CONVENTION SHALL CONFORM TO JEDEC 95-1 SPP-012. DETAILS OF TERMINAL #1 IDENTIFIER ARE OPTIONAL, BUT MUST BE LOCATED WITHIN THE ZONE INDICATED. THE TERMINAL #1 IDENTIFIER MAY BE EITHER A MOLD OR MARKED FEATURE.
- DIMENSION b APPLIES TO METALLIZED TERMINAL AND IS MEASURED BETWEEN 0.25 mm AND 0.30 mm FROM TERMINAL TIP.
- ND AND NE REFER TO THE NUMBER OF TERMINALS ON EACH D AND E SIDE RESPECTIVELY.
- DEPOPULATION IS POSSIBLE IN A SYMMETRICAL FASHION.
- COPLANARITY APPLIES TO THE EXPOSED HEAT SINK SLUG AS WELL AS THE TERMINALS.
- DRAWING CONFORMS TO JEDEC MO220, EXCEPT FOR T2444-1, T2444-3 AND T2444-4.

<small>PROPRIETARY INFORMATION</small>	
<small>TITLE: PACKAGE OUTLINE 12, 16, 20, 24L THIN QFN, 4x4x0.8mm</small>	
<small>APPROVAL</small>	<small>DOCUMENT CONTROL NO. 21-0139</small>
<small>REV. C</small>	<small>2/2</small>

Dual, Ultra-Low-Power, 10-Bit, Voltage-Output DACs

Package Information (continued)

(The package drawing(s) in this data sheet may not reflect the most current specifications. For the latest package outline information, go to www.maxim-ic.com/packages.)

MAX5522-MAX5525

8LUMAXDEPS

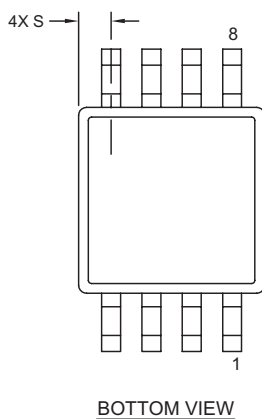
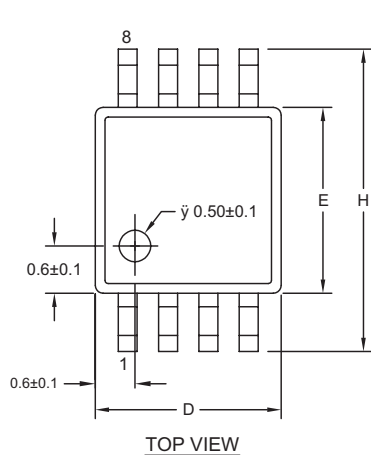

DIM	INCHES		MILLIMETERS	
	MIN	MAX	MIN	MAX
A	-	0.043	-	1.10
A1	0.002	0.006	0.05	0.15
A2	0.030	0.037	0.75	0.95
b	0.010	0.014	0.25	0.36
c	0.005	0.007	0.13	0.18
D	0.116	0.120	2.95	3.05
e	0.0256 BSC		0.65 BSC	
E	0.116	0.120	2.95	3.05
H	0.188	0.198	4.78	5.03
L	0.016	0.026	0.41	0.66
α	0 $^\infty$	6 $^\infty$	0 $^\infty$	6 $^\infty$
S	0.0207 BSC		0.5250 BSC	

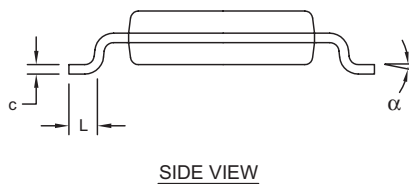
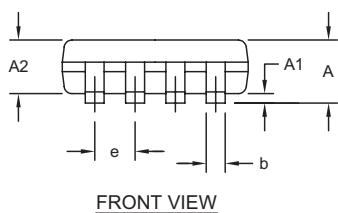

NOTES:

1. D&E DO NOT INCLUDE MOLD FLASH.
2. MOLD FLASH OR PROTRUSIONS NOT TO EXCEED 0.15MM (.006").
3. CONTROLLING DIMENSION: MILLIMETERS.
4. MEETS JEDEC MO-187C-AA.

<small>PROPRIETARY INFORMATION</small>	
<small>TITLE:</small> PACKAGE OUTLINE, 8L uMAX/uSOP	
<small>APPROVAL</small>	<small>DOCUMENT CONTROL NO.</small> 21-0036
<small>REV.</small> J	<small>REV.</small> 1/1

Maxim cannot assume responsibility for use of any circuitry other than circuitry entirely embodied in a Maxim product. No circuit patent licenses are implied. Maxim reserves the right to change the circuitry and specifications without notice at any time.

Maxim Integrated Products, 120 San Gabriel Drive, Sunnyvale, CA 94086 408-737-7600 23