

MAXIM

Dual, Serial-Input, Voltage-Output, 12-Bit MDAC

MAX532

General Description

The MAX532 is a complete, dual, serial-input, 12-bit multiplying digital-to-analog converter (MDAC) with output amplifiers. No external user trims are required to achieve full specified performance. The MAX532's 3-wire serial interface minimizes the number of package pins, so it uses less board space than parallel-interface parts. The interface is SPI™, QSPI™ and Microwire™ compatible. A serial output, DOUT, allows cascading of two or more MAX532s and read-back of the data written to the device.

The device's serial interface minimizes digital-noise feedthrough from its logic pins to its analog outputs. Serial interfacing also simplifies opto-coupler-isolated or transformer-isolated applications.

The MAX532 is specified with $\pm 12\text{V}$ to $\pm 15\text{V}$ power supplies. All logic inputs are TTL and CMOS compatible. It comes in space-saving 16-pin DIP and wide SO packages.

Applications

Automatic Test Equipment
Arbitrary Waveform Generators
Programmable-Gain Amplifiers
Motion Control Systems
Servo Controls

Functional Diagram

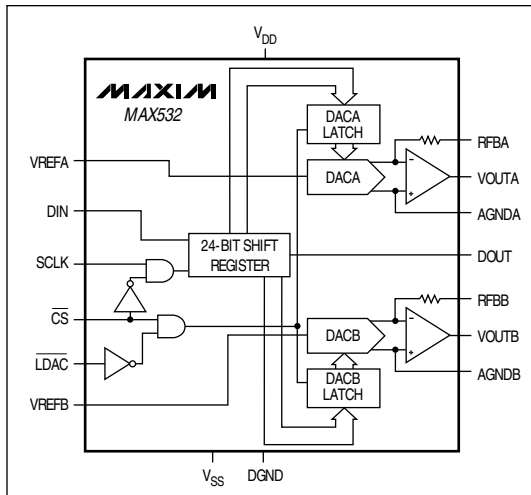

Features

- ♦ Two 12-Bit MDACs with Output Amplifiers
- ♦ Fast, 6MHz 3-Wire Interface
- ♦ SPI, QSPI, and Microwire Compatible
- ♦ $\pm 12\text{V}$ Output Swing
- ♦ $\pm 10\text{mA}$ Output Current
- ♦ 2.5 μs Settling Time to $\pm 1/2\text{LSB}$
- ♦ Guaranteed Monotonic Over Temperature
- ♦ Low Integral Nonlinearity: $\pm 1/2\text{LSB}$ Max
- ♦ Low Gain Tempco: 2ppm/°C
- ♦ Operates from $\pm 12\text{V}$ to $\pm 15\text{V}$ Supplies
- ♦ Power-On Reset
- ♦ Available in 16-Pin DIP and Wide SO Packages

Ordering Information

PART	TEMP. RANGE	PIN-PACKAGE	ERROR (LSBs)
MAX532ACPE	0°C to +70°C	16 Plastic DIP	$\pm 1/2$
MAX532BCPE	0°C to +70°C	16 Plastic DIP	± 1
MAX532ACWE	0°C to +70°C	16 Wide SO	$\pm 1/2$
MAX532BCWE	0°C to +70°C	16 Wide SO	± 1
MAX532BC/D	0°C to +70°C	Dice*	± 1

Ordering Information continued on last page.

* Contact factory for dice specifications.

Pin Configuration

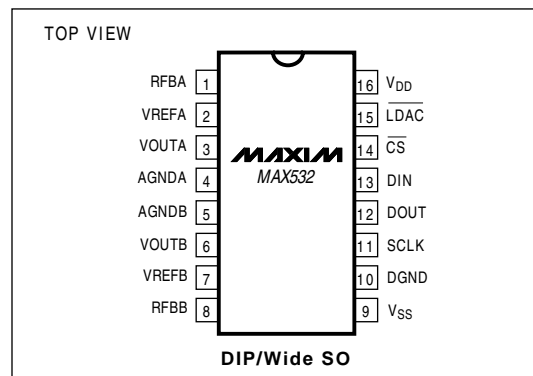

™Microwire is a trademark of National Semiconductor Corp. SPI and QSPI are trademarks of Motorola, Inc.

MAXIM

Maxim Integrated Products 1

Call toll free 1-800-998-8800 for free samples or literature.

Dual, Serial-Input, Voltage-Output, 12-Bit MDAC

ABSOLUTE MAXIMUM RATINGS

Pin Voltages

V _{DD} to DGND, AGNDA, AGNDB	-0.3V to +17V
V _{SS} to DGND, AGNDA, AGNDB (Note 1)	+0.3V to -17V
VREFA, VREFB	(V _{SS} - 0.3V) to (V _{DD} + 0.3V)
AGNDA, AGNDB	(DGND - 0.3V) to (V _{DD} + 0.3V)
VOUTA, VOUTB	(V _{SS} - 0.3V) to (V _{DD} + 0.3V)
RFBA, RFB	(V _{SS} - 0.3V) to (V _{DD} + 0.3V)
SCLK, DIN, DOUT, LDAC, CS	(DGND - 0.3V) to (V _{DD} + 0.3V)
DOUT Sink Current	20mA
Continuous Power Dissipation (T _A = +70°C)	
Plastic DIP (derate 10.53mW/°C above +70°C)	842mW
Wide SO (derate 9.52mW/°C above +70°C)	762mW
CERDIP (derate 10.00mW/°C above +70°C)	800mW

Operating Temperature Ranges:

MAX532_C_	0°C to +70°C
MAX532_E_	-40°C to +85°C
MAX532_MJE	-55°C to +125°C
Junction Temperatures:	
MAX532_C_, E_	+150°C
MAX532_MJE	+175°C
Storage Temperature Range	-65°C to +160°C
Lead Temperature (soldering, 10sec)	+300°C

Note 1: If V_{SS} is open-circuited with V_{DD} and either AGND applied, the V_{SS} pin will float positive, exceeding the Absolute Maximum Ratings. A Schottky diode connected between V_{SS} and GND ensures the maximum ratings will not be exceeded.

Stresses beyond those listed under "Absolute Maximum Ratings" may cause permanent damage to the device. These are stress ratings only, and functional operation of the device at these or any other conditions beyond those indicated in the operational sections of the specifications is not implied. Exposure to absolute maximum rating conditions for extended periods may affect device reliability.

ELECTRICAL CHARACTERISTICS

(V_{DD} = 11.4V to 16.5V, V_{SS} = -11.4V to -16.5V, AGNDA = AGNDB = DGND = 0V, VREFA and VREFB = +10V, R_L = 2kΩ, C_L = 100pF, VOUT_ connected to RFB_, T_A = T_{MIN} to T_{MAX}, unless otherwise noted.)

PARAMETER	SYMBOL	CONDITIONS	MIN	TYP	MAX	UNITS
STATIC PERFORMANCE (Note 1)						
Resolution			12			Bits
Relative Accuracy	INL	MAX532A			±1/2	LSB
		MAX532B			±1	
Differential Nonlinearity		Guaranteed monotonic			±1	LSB
Zero-Code Offset Error		DAC latch loaded with all 0s	T _A = +25°C, MAX532_		±2	mV
			T _A = T _{MIN} to T _{MAX} , MAX532A		±3	
			T _A = T _{MIN} to T _{MAX} , MAX532B		±4	
Zero-Code Offset Temperature Coefficient		DAC latch loaded with all 0s		±5		μV/°C
Gain Error		T _A = +25°C, DAC latch loaded with all 1s	MAX532A		±2	LSB
			MAX532B		±5	
		T _A = T _{MIN} to T _{MAX} , DAC latch loaded with all 1s	MAX532A		±4	
			MAX532B		±7	
Gain-Error Temperature Coefficient				±2		ppm/°C of FSR
REFERENCE INPUTS (VREFA, VREFB)						
VREFA, VREFB Input Resistance			8	10	13	kΩ
VREFA, VREFB Input Resistance Matching				±0.5	±3.0	%

Dual, Serial-Input, Voltage-Output, 12-Bit MDAC

MAX532

ELECTRICAL CHARACTERISTICS (continued)

($V_{DD} = 11.4V$ to $16.5V$, $V_{SS} = -11.4V$ to $-16.5V$, $AGNDA = AGNDB = DGND = 0V$, $VREFA$ and $VREFB = +10V$, $R_L = 2k\Omega$, $C_L = 100pF$, $VOUT_+$ connected to RFB_+ , $T_A = T_{MIN}$ to T_{MAX} , unless otherwise noted.)

PARAMETER	SYMBOL	CONDITIONS	MIN	TYP	MAX	UNITS
DIGITAL INPUTS (SCLK, DIN, LDAC, CS)						
Input High Voltage	V_{INH}		2.4			V
Input Low Voltage	V_{INL}				0.8	V
Input Current		Digital inputs at 0V or V_{DD}			± 1	μA
Input Capacitance (Note 2)					8	pF
DIGITAL OUTPUT (DOUT) (Note 3)						
Output Voltage Low	V_{OL}	$I_{SINK} = 5mA$		0.08	0.4	V
		$I_{SINK} = 16mA$		0.2		
Output High Leakage	I_{LKG}	$V_{DOUT} = 0V$ to V_{DD}			± 10	μA
Output High Capacitance (Note 2)	C_{OUT}				15	pF
ANALOG OUTPUTS (VOUTA, VOUTB)						
DC Output Impedance				0.2		Ω
Short-Circuit Current		$VOUTA$, $VOUTB$ connected to $AGNDA$, $AGNDB$		20		mA
Output Voltage Swing			$(V_{DD} - 2.5)$ to $(V_{SS} + 2.5)$			V
POWER REQUIREMENTS						
Positive Supply Voltage	V_{DD}		11.4		16.5	V
Negative Supply Voltage	V_{SS}		-11.4		-16.5	V
Power-Supply Rejection	PSR	$\Delta Full\ scale/\Delta V_{DD}$, $V_{DD} = 11.4V$ to $16.5V$, $VREF = -8.9V$, DAC latches loaded with all 1s			± 0.035	LSB/%
		$\Delta Full\ scale/\Delta V_{SS}$, $V_{SS} = -11.4V$ to $-16.5V$, $VREF = 8.9V$, DAC latches loaded with all 1s			± 0.035	
Positive Supply Current	I_{DD}	Output unloaded		5	10	mA
Negative Supply Current	I_{SS}	Output unloaded		4	6	mA
AC CHARACTERISTICS						
Voltage-Output Settling Time		Settling time to within 1/2 LSB of final DAC value; DAC latch alternately loaded with all 0s and all 1s		2.5		μs
Slew Rate				8		V/ μs
Digital-to-Analog Glitch Impulse		DAC latch alternately loaded with 011...11 and 100...00		60		nV-s
Channel-to-Channel Isolation		$VREFA$ to $VOUTB$	$VREFA = 20V_{p-p}$ 10kHz sine wave; DAC latches loaded with all 0s		-100	dB
		$VREFB$ to $VOUTA$	$VREFB = 20V_{p-p}$ 10kHz sine wave; DAC latches loaded with all 0s		-100	

Dual, Serial-Input, Voltage-Output, 12-Bit MDAC

ELECTRICAL CHARACTERISTICS (continued)

($V_{DD} = 11.4V$ to $16.5V$, $V_{SS} = -11.4V$ to $-16.5V$, $AGNDA = AGNDB = DGND = 0V$, V_{REFA} and $V_{REFB} = +10V$, $R_L = 2k\Omega$, $C_L = 100pF$, $V_{OUT_}$ connected to $R_{FB_}$, $T_A = T_{MIN}$ to T_{MAX} , unless otherwise noted.)

PARAMETER	SYMBOL	CONDITIONS	MIN	TYP	MAX	UNITS
Multiplying Feedthrough Error		$V_{REF} = 20V_{p-p}$ 10kHz sine wave; DAC latch loaded with all 0s		-77		dB
Unity-Gain Small-Signal Bandwidth		$V_{REF} = 100mV_{p-p}$ sine wave; DAC latch loaded with all 1s		1.0		MHz
Full-Power Bandwidth		$V_{REF} = 20V_{p-p}$ sine wave; DAC latch loaded with all 1s		125		kHz
Total Harmonic Distortion	THD	$V_{REF} = 6V_{RMS}$, 1kHz sine wave; DAC latch loaded with all 1s		-90		dB
Digital Feedthrough		$CS = 1$; transitions on SCLK, LDAC, DIN		1.1		nV-s
Digital Crosstalk		DACA code all 1s, DACB code transition from all 0s to all 1s		10		nV-s
Output Noise Voltage		0.1Hz to 10Hz		2		μV_{RMS}

Note 1: Static performance tested at $V_{DD} = +15V$, $V_{SS} = -15V$. Performance over supplies guaranteed by PSR test.

Note 2: Guaranteed by design. Not subject to production testing.

Note 3: Open-drain output.

TIMING CHARACTERISTICS

($V_{DD} = 11.4V$ to $16.5V$, $V_{SS} = -11.4V$ to $-16.5V$, $AGNDA = AGNDB = DGND = 0V$) (Notes 4, 5)

PARAMETER	SYMBOL	CONDITIONS	MIN	TYP	MAX	UNITS
SCLK Clock Frequency	f_{CLK}				6.25	MHz
SCLK Pulse Width High	t_{CH}		80			ns
SCLK Pulse Width Low	t_{CL}		80			ns
DIN to SCLK Rise Setup Time	t_{DS}		50			ns
DIN to SCLK Rise Hold Time	t_{DH}		0			ns
CS Fall to SCLK Rise Setup Time	t_{CSS0}		50			ns
CS Rise to SCLK Rise Setup Time	t_{CSS1}		50			ns
SCLK Fall to CS Fall Hold Time	t_{CSH0}		5			ns
SCLK Rise to CS Rise Hold Time	t_{CSH1}		80			ns
CS Pulse Width High	t_{CSW}		120			ns
SCLK Fall to DOUT Valid (Note 6)	t_{DO}	$C_L = 20pF$, $R_{PULL-UP} = 1k\Omega$ to 5V	0		200	ns
CS Fall to DOUT Enable (Note 7)	t_{DV}	$C_L = 20pF$, $R_{PULL-UP} = 1k\Omega$ to 5V			100	ns
CS Rise to DOUT Disable (Note 7)	t_{TR}	$C_L = 20pF$, $R_{PULL-UP} = 1k\Omega$ to 5V			60	ns
LDAC Pulse Width Low	t_{LDAC}		60			ns
CS Rise to LDAC Fall Setup Time	t_{LDACS}		100			ns

Note 4: All input signals are specified with $t_R = t_F \leq 5ns$. Logic input swing is 0V to 5V.

Note 5: See Figure 1.

Note 6: Timing is for SCLK fall to DOUT fall to 0.8V, or for SCLK fall to DOUT rise to 2.4V. Additional time must be added for any larger passive RC pull-up delay.

Note 7: DOUT enable: DOUT falls to 4.5V from 5.0V. DOUT disable: DOUT rises to 0.5V from 0V.

Dual, Serial-Input, Voltage-Output, 12-Bit MDAC

Typical Operating Characteristics

($V_{DD} = 15V$, $V_{SS} = -15V$, $R_L = 2k\Omega$, $C_L = 100pF$, unless otherwise noted.)

MAX532

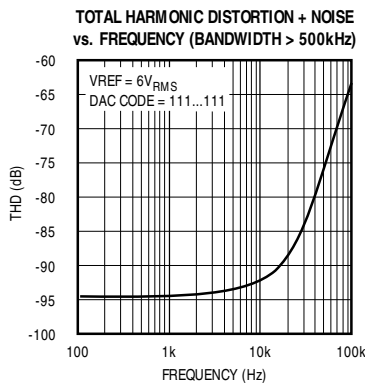
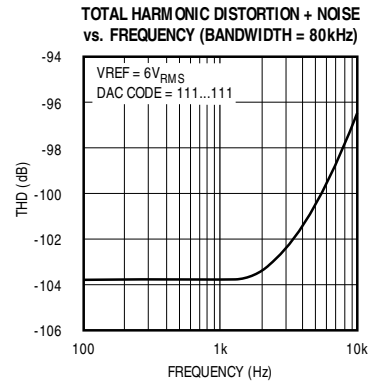
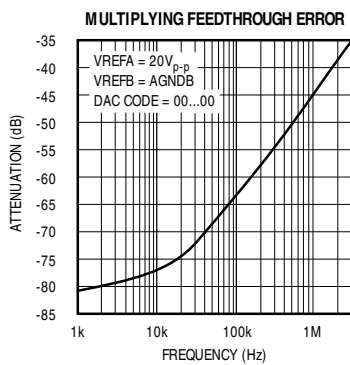
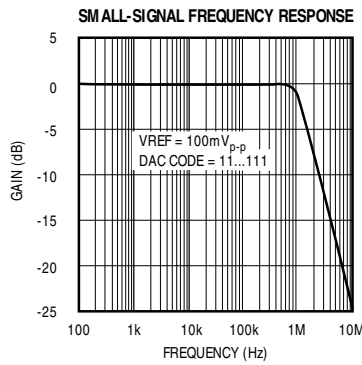
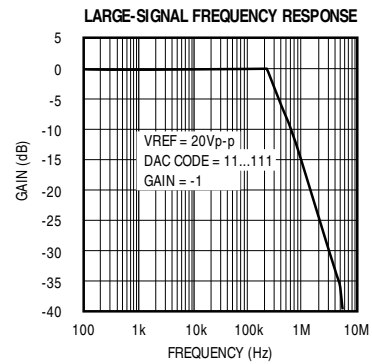
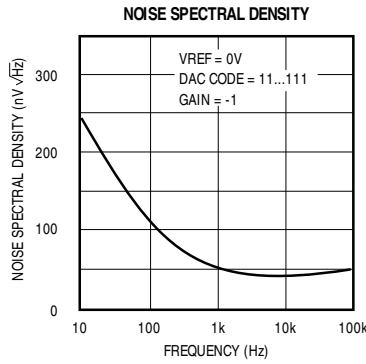
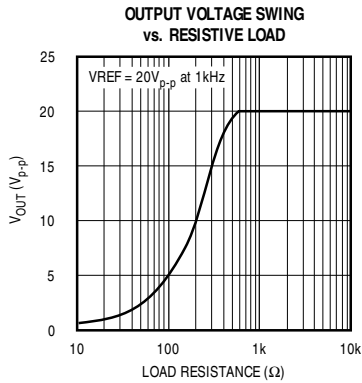

Dual, Serial-Input, Voltage-Output, 12-Bit MDAC

Typical Operating Characteristics (continued)

($V_{DD} = 15V$, $V_{SS} = -15V$, $R_L = 2k\Omega$, $C_L = 100pF$, unless otherwise noted.)

SMALL-SIGNAL PULSE RESPONSE

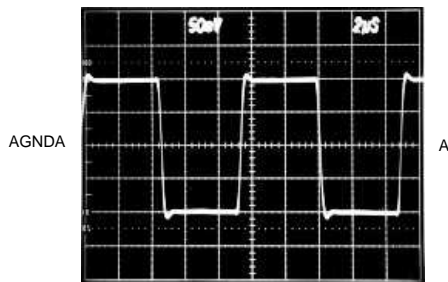

A = V_{OUTA} , 50mV/div
TIMEBASE = 2µs/div
 $V_{REFA} = \pm 100mV$ SQUARE WAVE

LARGE-SIGNAL PULSE RESPONSE

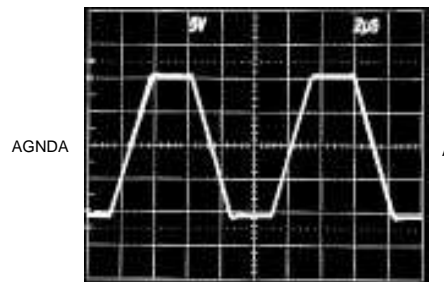

A = V_{OUTA} , 5V/div
TIMEBASE = 2µs/div
 $V_{REFA} = \pm 10V$ SQUARE WAVE

Pin Description

PIN	NAME	FUNCTION
1	RFBA	Feedback Resistor for DACA
2	VREFA	Reference Input for DACA
3	VOUTA	Voltage Output for DACA
4	AGNDA	Analog Ground for DACA
5	AGNDB	Analog Ground for DACB
6	VOUTB	Voltage Output for DACB
7	VREFB	Reference Input for DACB
8	RFBB	Feedback Resistor for DACB
9	V_{SS}	Negative Supply Voltage
10	DGND	Digital Ground
11	SCLK	Serial Clock Input
12	DOUT	Serial Data Output. Open-drain N-channel MOSFET output: requires external pull-up resistor. Data on DOUT changes on the falling edge of SCLK. Serial output data is delayed 24 clock cycles from DIN.
13	DIN	Serial Data Input. CMOS- and TTL-compatible input. Data is clocked into DIN on the rising edge of SCLK. CS must be low for data to be clocked in.
14	\overline{CS}	Chip-Select Input, active low. Data is shifted in and out when \overline{CS} is low. DAC latches are updated when CS is high and LDAC is low.
15	\overline{LDAC}	Asynchronous Load DAC Input, active low. DAC latches are updated when CS is high and \overline{LDAC} is low.
16	V_{DD}	Positive Supply Voltage

Dual, Serial-Input, Voltage-Output, 12-Bit MDAC

Timing Diagrams

MAX532

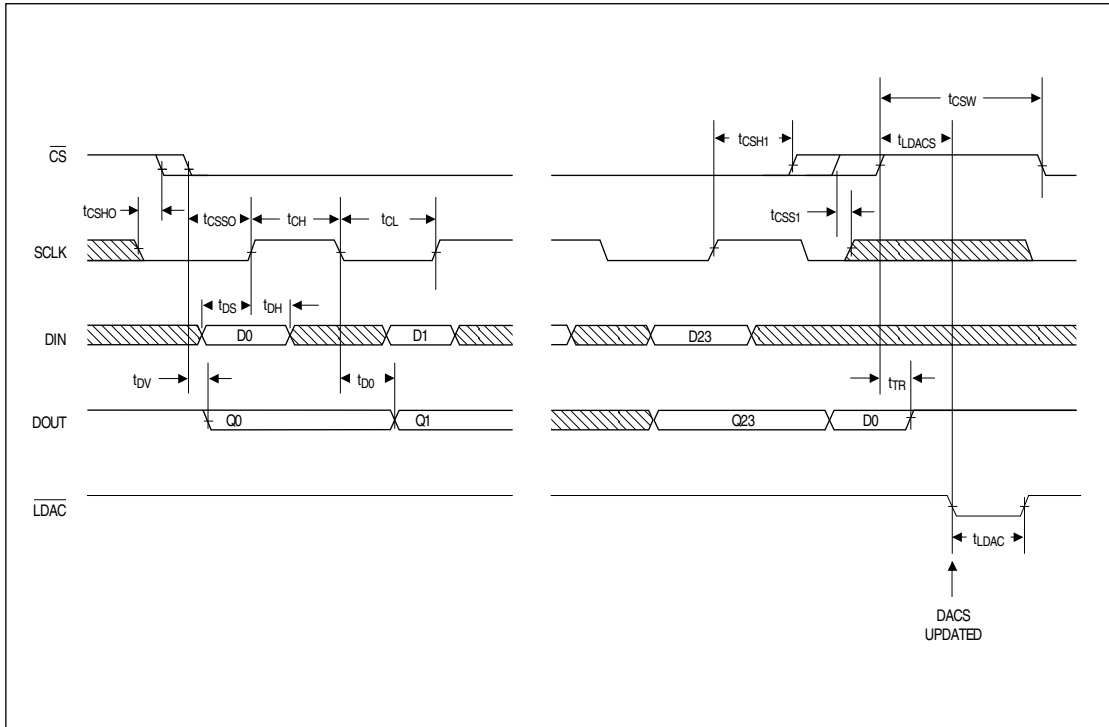

Figure 1. Timing Diagram

Dual, Serial-Input, Voltage-Output, 12-Bit MDAC

Timing Diagrams (continued)

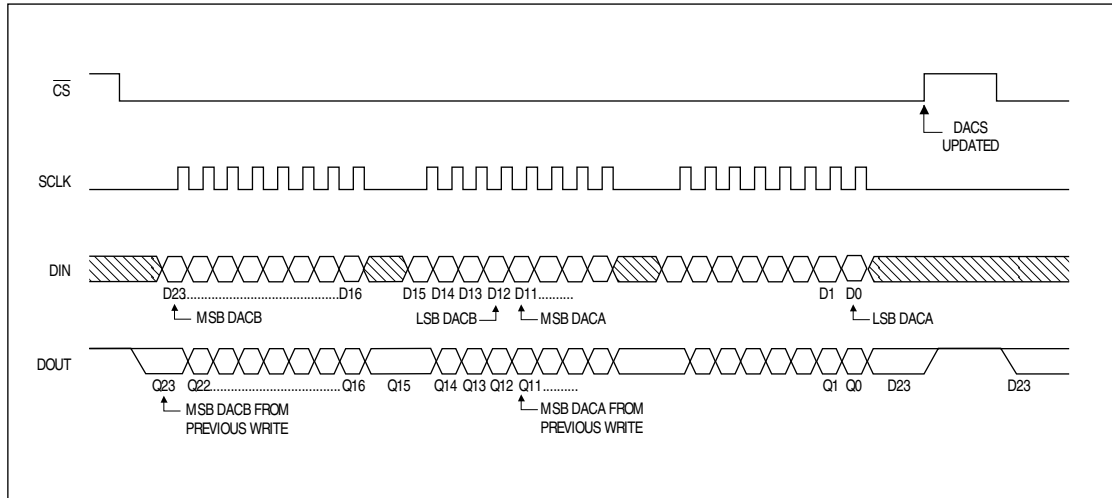

Figure 2. 3-Wire Interface Timing Diagram (LDAC = DGND)

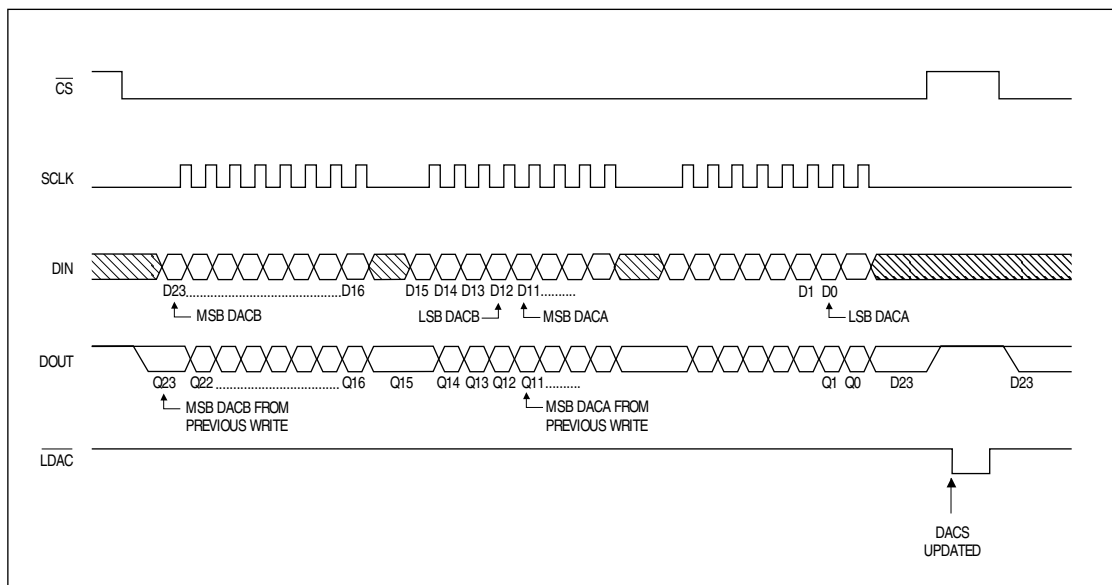

Figure 3. 4-Wire Interface Timing Diagram

Dual, Serial-Input, Voltage-Output, 12-Bit MDAC

MAX532

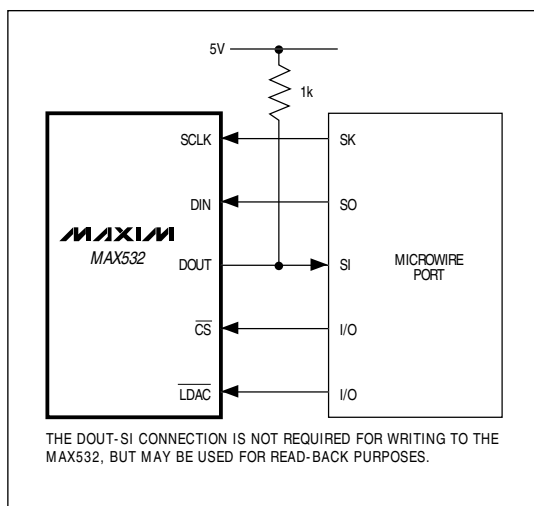

Figure 4. Connections for Microwire

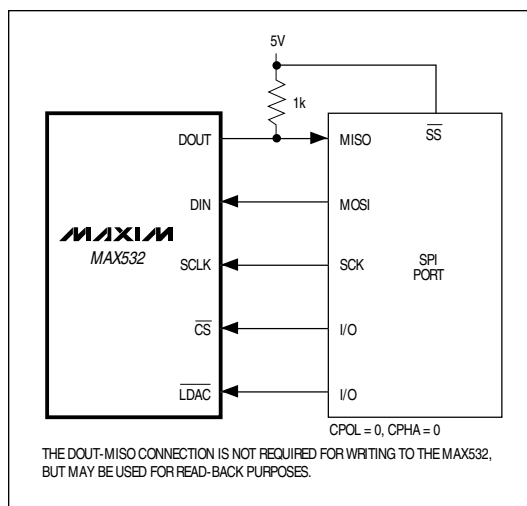

Figure 5. Connections for SPI

Detailed Description

Digital Interface

The MAX532 is Microwire and SPI compatible (Figures 4 and 5). Both DACs are programmed by writing three 8-bit words (see Figures 2 and 3, and the *Functional Diagram*). Serial data is clocked into the data registers MSB first, with DACB information preceding DACA information. Data is clocked in on the rising edge of SCLK while CS is low. With CS high, data can not be clocked into DIN, and DOUT is high impedance. SCLK can be driven at rates up to 6.25MHz.

The MAX532 uses either a 3-wire or a 4-wire serial interface. Three wires may be used (\overline{CS} , DIN, SCLK) by tying LDAC low. With LDAC low, the DACs are updated simultaneously when \overline{CS} goes high (see Figure 2 and the *Functional Diagram*). The 3-wire interface may be used if the MAX532 is used alone, or if two or more MAX532s are cascaded (DOUT of one device tied to DIN of the other) (Figure 6).

The 4-wire interface (\overline{LDAC} , \overline{CS} , DIN, SCLK) is required if several serial devices are tied to the same data line, and it is desirable to update them simultaneously (Figure 7). With the 4-wire interface, the DACs are updated when \overline{LDAC} goes low (see Figure 3 and the *Functional Diagram*).

A serial output, DOUT, allows cascading of two or more MAX532s and allows read-back of the data written to

the device's 24-bit shift register. The data at DOUT is delayed 24 clock cycles from the data at DIN (see Figures 2 and 3, and the *Functional Diagram*). DOUT is an open-drain N-channel MOSFET that requires an external pull-up resistor (typically 1k Ω if pulled up to +5V, and 3k Ω if pulled up to +12V or +15V). Logic levels are guaranteed with sink currents up to 5mA (see *Electrical Characteristics*). Output data changes on the falling edge of SCLK when \overline{CS} is low. If \overline{CS} is high, DOUT is three-state (high-impedance).

Daisy-Chaining Devices

Any number of MAX532s can be daisy-chained by connecting the DOUT pin of one device (with a pull-up resistor) to the DIN pin of the following device in the chain (Figure 6).

When daisy-chaining devices, t_{CSS0} (\overline{CS} low to SCLK high), must be the greater of $t_{DV} + t_{DS}$ or $t_{DS} + (t_{RC} + t_{TR} - t_{CS})$, where t_{CSW} is the \overline{CS} pulse width used in the system and the term $(t_{RC} + t_{TR} - t_{CSW})$ accounts for the time spent charging the DOUT capacitance with the external pull-up resistor. So, for $t_{RC} < 250\text{ns}$, t_{CSS0} is simply $t_{DV} + t_{DS}$. Calculate t_{RC} using the following equation:

$$t_{RC} = R_p \times C \times \ln(V_{PULL-UP}/(V_{PULL-UP} - 2.4V))$$

where $V_{PULL-UP}$ is the voltage that the pull-up resistor is connected to, R_p is the value of the pull-up resistor, and C is the capacitance at DOUT. Values of t_{RC} are given in Table 1.

Dual, Serial-Input, Voltage-Output, 12-Bit MDAC

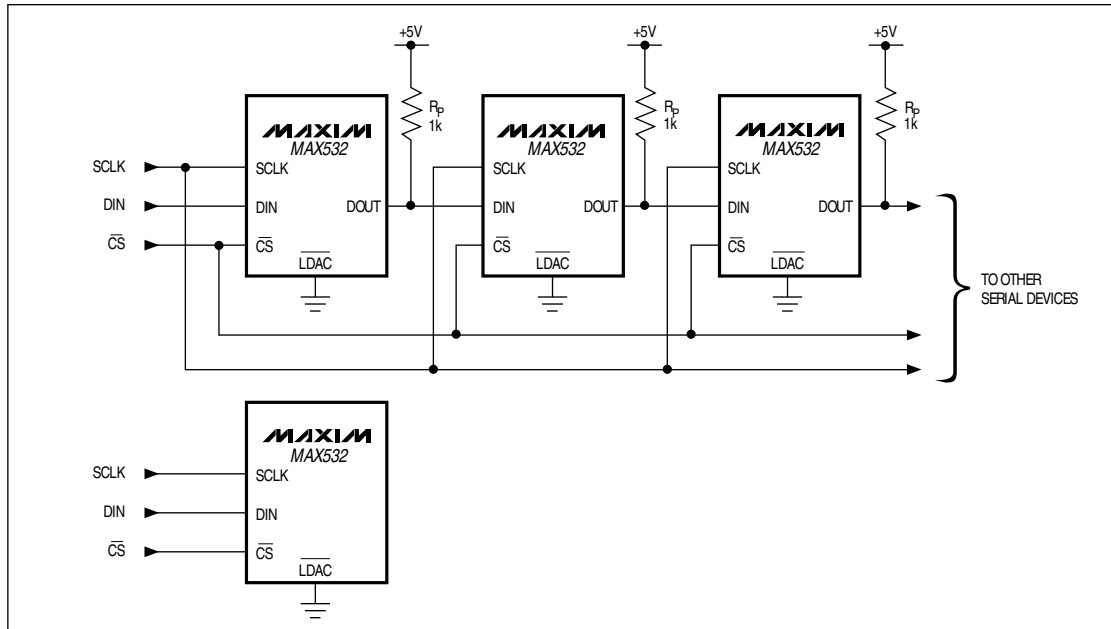

Figure 6. Daisy-chained or individual MAX532s are simultaneously updated by bringing CS high when using the 3-wire interface (LDAC = DGND).

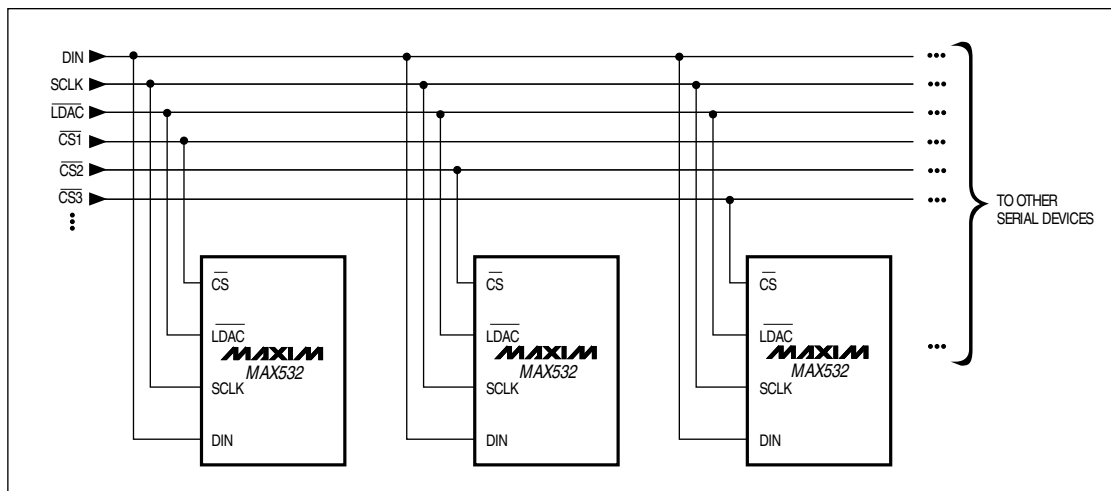

Figure 7. Multiple devices sharing a common DIN line may be simultaneously updated by bringing LDAC low. CS1, CS2, CS3, . . . , are driven separately, thus controlling which data are written to devices 1, 2, 3,

Dual, Serial-Input, Voltage-Output, 12-Bit MDAC

MAX532

Table 1. t_{RC} Delay Times

V _{PULL-UP} (V)	C (pF)	R _P (k Ω)	t_{RC} (ns)
4.5	20	1	15
4.5	35	1	27
4.5	50	1	38
4.5	100	1	76
4.5	150	1	114
11.4	20	3	14
11.4	35	3	25
11.4	50	3	35
11.4	100	3	71
11.4	150	3	106
13.5	20	3	12
13.5	35	3	21
13.5	50	3	29
13.5	100	3	59
13.5	150	3	88

With the values of t_{RC} given in Table 1, t_{CSS0} is always given by $t_{DV} + t_{DS}$. For different values of R or C, t_{RC} must be calculated to determine t_{CSS0} .

Additionally, the maximum clock frequency is limited to

$$f_{CLK}(\max) = \frac{1}{2 \times (t_{DO} + t_{RC} - 15\text{ns} + t_{DS})}$$

For example, with $t_{RC} = 15\text{ns}$ (5V \pm 10% supply with 1k Ω pull-up), the maximum clock frequency is 2MHz.

Digital-to-Analog Section

Figure 8 shows a simplified circuit diagram for one of the DACs and the output amplifier.

A segmented scheme is used to improve linearity, whereby the two MSBs of the 12-bit data word are decoded to drive the three switches, SA, SB, and SC. The remaining ten bits drive the switches S0 through S9 in a standard R-2R ladder configuration.

Each of the switches, SA, SB, and SC, steers 1/4 of the total reference current with the remaining 1/4 passing through the R-2R section.

The output amplifier and feedback resistor perform the current-to-voltage conversion, giving the following:

$$V_{OUT_} = -D \times V_{REF_}$$

where $_$ denotes A or B, and D is the fractional representation of the digital word. (D can be set from 0 to 4095/4096.)

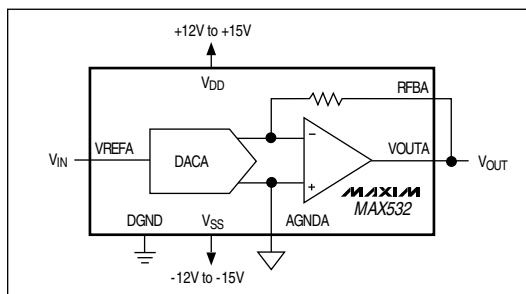

Figure 9. Unipolar Binary Operation

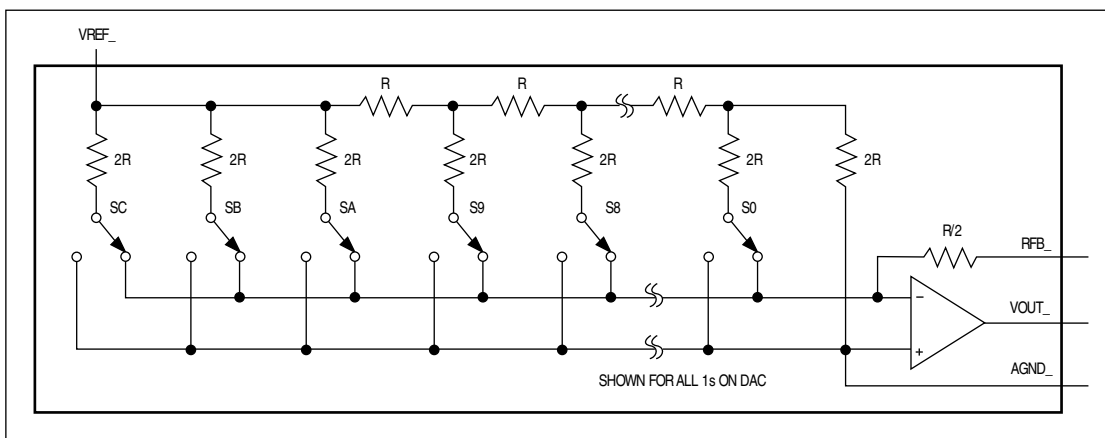

Figure 8. Simplified D/A Circuit Diagram

Dual, Serial-Input, Voltage-Output, 12-Bit MDAC

Output Amplifiers

The output amplifiers are stable with any combination of resistive loads $\geq 2k\Omega$ and capacitive loads $\leq 100pF$. They are internally compensated, and settle to $\pm 0.01\%$ FSR (1/2LSB) in 2.5 μs .

Unipolar Configuration

Figure 9 shows DACA connected for unipolar binary operation. Similar connections apply for DACB. When V_{IN} is an AC signal, the circuit performs two-quadrant multiplication. Table 2 shows the codes for this circuit.

Bipolar Operation

Figure 10 shows the MAX532 connected for bipolar operation. The coding is offset binary, as shown in Table 3. When V_{IN} is an AC signal, the circuit performs four-quadrant multiplication. To maintain gain error specifications, resistors R1, R2, and R3 should be ratio-matched to 0.01%.

Table 2. Unipolar Code Table

DAC Latch Contents		Analog Output, V_{OUT}
MSB	LSB	
1111	1111 1111	$-V_{IN} \times (4095/4096)$
1000	0000 0000	$-V_{IN} \times (2048/4096) = -1/2V_{IN}$
0000	0000 0001	$-V_{IN} \times (1/4096)$
0000	0000 0000	0V

1LSB = $V_{IN}/4096$

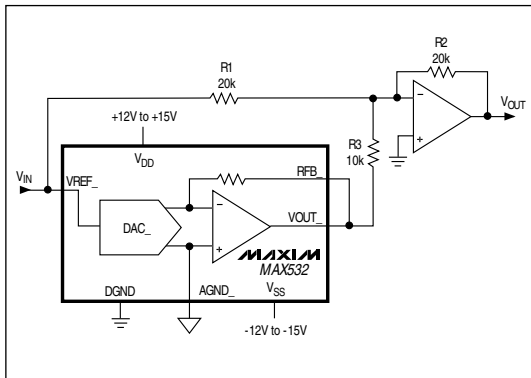

Figure 10. Bipolar Operation

Applications Information

Layout, Grounding, and Bypassing

For best system performance, use printed circuit boards with separate analog and digital ground planes. Wire-wrap boards are not recommended. The two ground planes should be tied together at the low-impedance power-supply source, as shown in Figure 11.

The board layout should ensure that digital and analog signal lines are kept separate from each other as much as possible. Do not run analog and digital lines parallel to one another.

The output amplifiers are sensitive to high-frequency noise in the V_{DD} and V_{SS} power supplies. Bypass these supplies to the analog ground plane with 0.1 μF and 10 μF bypass capacitors. Minimize capacitor lead lengths for best noise rejection.

Table 3. Bipolar Code Table

DAC Latch Contents		Analog Output, V_{OUT}
MSB	LSB	
1111	1111 1111	$+V_{IN} \times (2047/2048)$
1000	0000 0001	$+V_{IN} \times (1/2048)$
1000	0000 0000	0V
0111	1111 1111	$-V_{IN} \times (1/2048)$
0000	0000 0000	$-V_{IN} + (2048/2048) = -V_{IN}$

1LSB = $V_{IN}/2048$

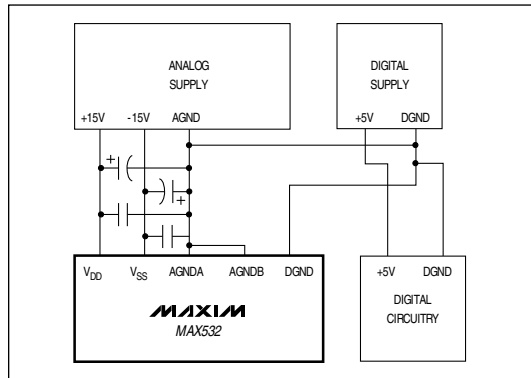

Figure 11. Power-Supply Grounding

Dual, Serial-Input, Voltage-Output, 12-Bit MDAC

MAX532

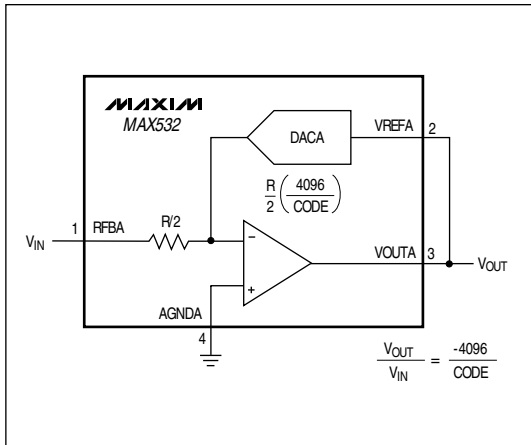

Figure 12. Programmable-Gain Amplifier

Programmable-Gain Amplifier (PGA)

The DAC/amplifier combination, along with access to the feedback resistors, makes the MAX532 ideal as a programmable-gain amplifier. In this application, the DAC functions as a programmable resistor in the feedback loop. This type of configuration is shown in Figure 12, and is suitable for AC gain control. The DAC code controls the gain for the PGA. As the code decreases, the effective DAC resistance increases, and so the gain also increases. The transfer function is given by:

$$V_{OUT}/V_{IN} = -REQA/RFBA,$$

where RFBA is the value of the feedback resistor (R/2), and REQA is the effective DAC resistance controlled by the digital input code:

$$REQA = \frac{R}{2} \left(\frac{4096}{CODE} \right),$$

where CODE is the DAC code in decimal.

The transfer function is thus:

$$\frac{V_{OUT}}{V_{IN}} = \frac{-4096}{CODE}$$

The code may be programmed between 1 and (2¹² - 1). The zero code is not allowed, as it results in an open-loop amplifier response.

Power-On Reset

On power-up, the internal DAC latches are set to 00 00.

Dual, Serial-Input, Voltage-Output, 12-Bit MDAC

MAX532

Ordering Information (continued)

PART	TEMP. RANGE	PIN-PACKAGE	ERROR (LSBs)
MAX532AEPE	-40°C to +85°C	16 Plastic DIP	±1/2
MAX532BEPE	-40°C to +85°C	16 Plastic DIP	±1
MAX532AEWE	-40°C to +85°C	16 Wide SO	±1/2
MAX532BEWE	-40°C to +85°C	16 Wide SO	±1
MAX532AMJE	-55°C to +125°C	16 CERDIP**	±1/2
MAX532BMJE	-55°C to +125°C	16 CERDIP**	±1

**Contact factory for availability and processing to MIL-STD-883B.

Chip Topography

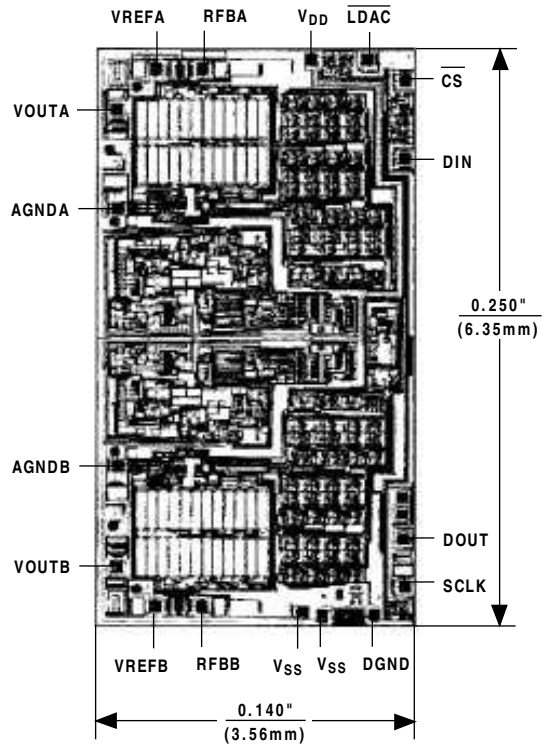

TRANSISTOR COUNT: 1324;
SUBSTRATE CONNECTED TO V_{DD}.

Dual, Serial-Input, Voltage-Output, 12-Bit MDAC

Package Information

MAX532

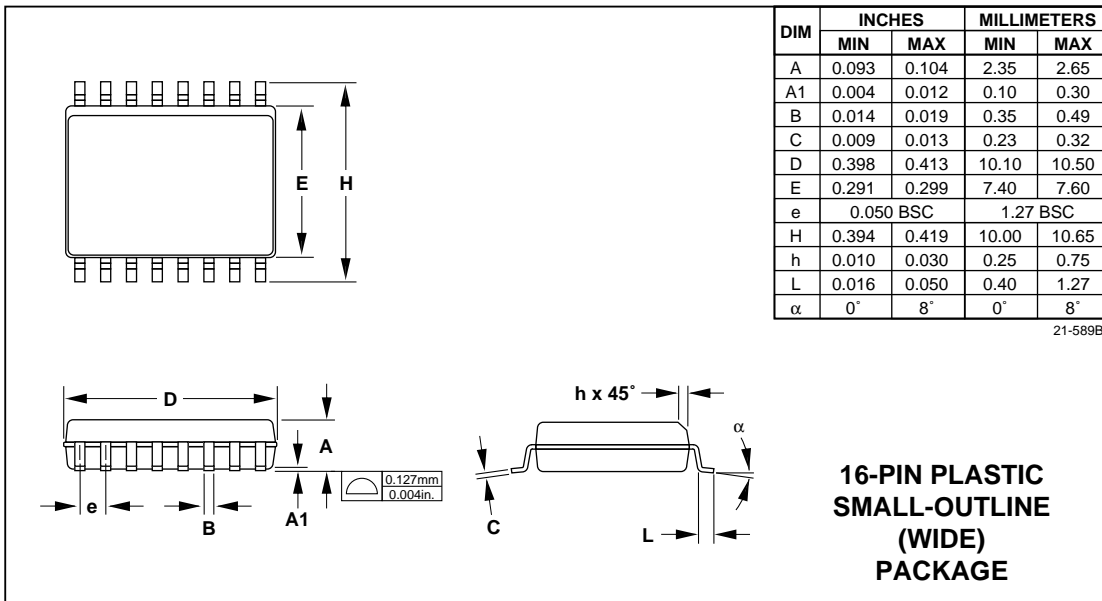
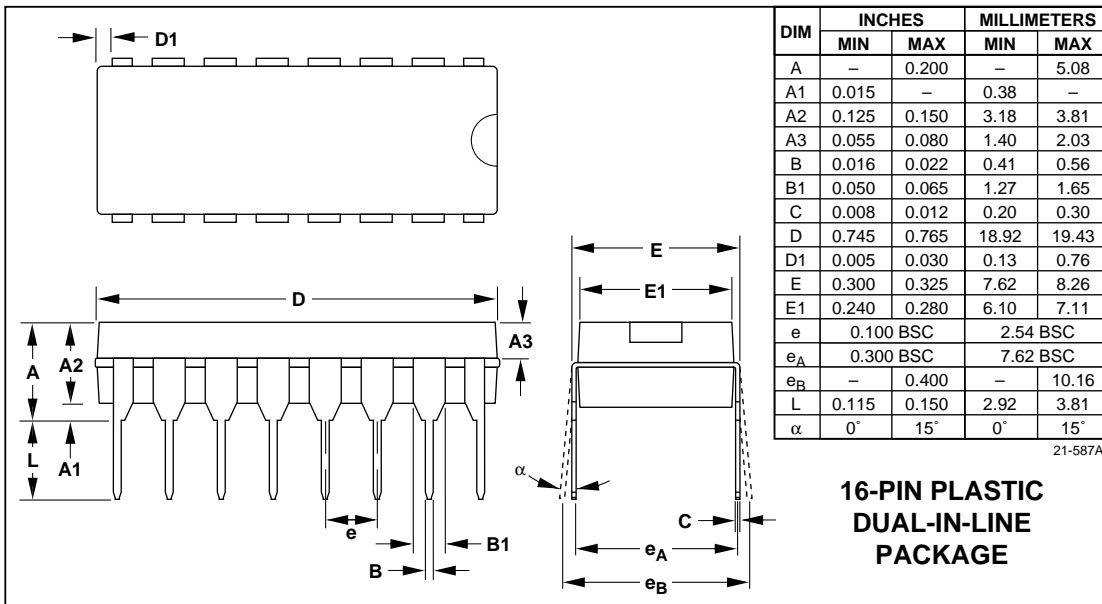

**Dual, Serial-Input,
Voltage-Output, 12-Bit MDAC**

MAX532

Maxim cannot assume responsibility for use of any circuitry other than circuitry entirely embodied in a Maxim product. No circuit patent licenses are implied. Maxim reserves the right to change the circuitry and specifications without notice at any time.

16 _____ **Maxim Integrated Products, 120 San Gabriel Drive, Sunnyvale, CA 94086 (408) 737-7600**

© 1994 Maxim Integrated Products

Printed USA

MAXIM is a registered trademark of Maxim Integrated Products.