



A Maxim Integrated Products Brand

PHY1040-01

125Mbps – 1.25Gbps VCSEL/Laser Driver and Postamplifier

Features

- Common anode VCSEL driver output stage with 32mA max modulation drive and 20mA bias current.
- Continuous mode LASER driver with up to 80mA modulation and 90mA bias current
- Closed or open loop bias mode with temperature lookup table
- Temperature compensated modulation current
- Limiting amplifier with programmable low pass filter and output swing
- Device settings stored in external 2k EEPROM

Applications

- Fast Ethernet
- Gigabit Ethernet
- OC-3

Description

The PHY1040-01 is a continuous mode VCSEL/Laser driver and limiting amplifier for use within fiber optic modules for SFP and SFF applications. Used with the PHY1092-01 or PHY1095-01 transimpedance amplifiers and a low cost serial EEPROM or microcontroller it forms a complete SFP module solution.

The transmit section integrates a modulator output stage optimised as a LASER or VCSEL driver in common anode configurations.

The bias current can be controlled either by a fast settling APC loop or in open loop mode which uses a temperature lookup table.

The receiver includes a limiting amplifier with programmable bandwidth. A Signal Detect/Loss Of Signal function is implemented using the input signal modulation amplitude with user selectable threshold and hysteresis.

Operating with a 3.3V supply and rated from -40 to +95°C ambient, the PHY1040-01 is housed in a 32pin, 5x5mm, RoHS compliant, QFN package.

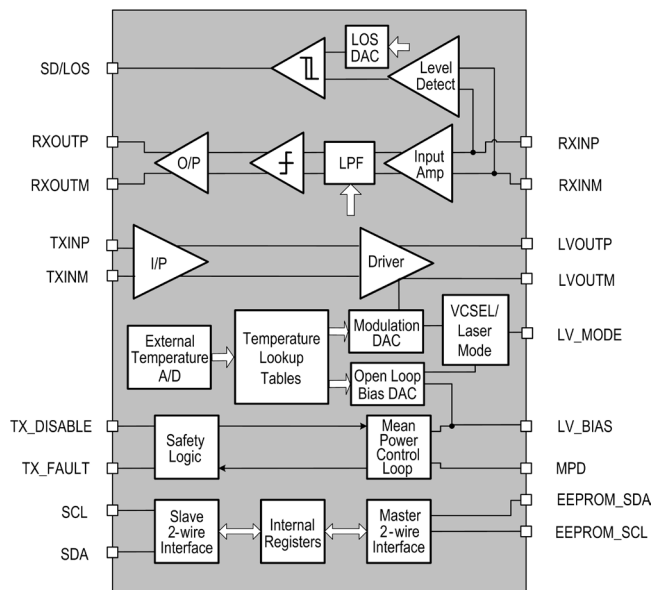

Figure 1 – Block diagram

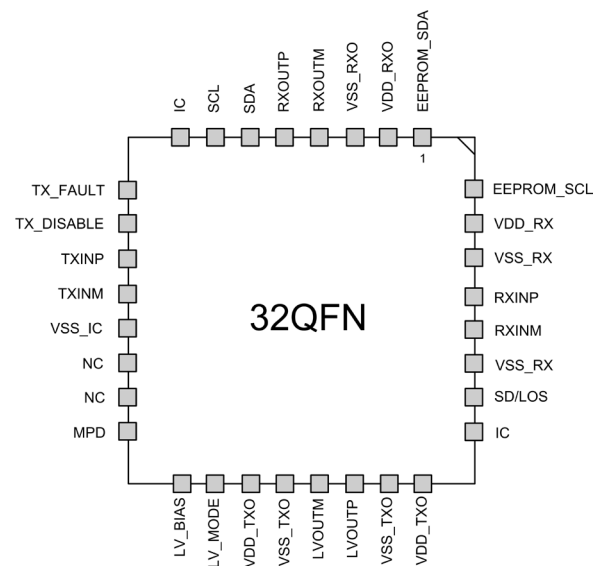

Figure 2 – Device pin out

Contents

1.	Ordering Information	3
2.	Pin description.....	3
3.	Key Specifications.....	5
3.1.	Absolute Maximum Ratings.....	5
3.2.	Continuous Ratings	5
3.3.	Transmitter	5
3.4.	Receiver	8
3.5.	2-Wire Serial Interface.....	12
4.	Functional Description.....	14
4.1.	Overview	14
4.2.	Transmitter features	14
4.3.	Receiver Features	21
4.4.	Laser/VCSEL Safety Features	23
4.5.	Temperature Measurement.....	26
5.	Control Interface.....	27
5.1.	Boot Sequence.....	28
5.2.	Main Control Loop.....	30
5.3.	2-wire Serial Interface	31
6.	Register Map.....	33
7.	Simplified Interface Models	45
8.	Applications Information.....	47
8.1.	Power Supply Connections	47
8.2.	VCSEL/Laser Connection – DC-Coupled.....	48
8.3.	VCSEL/Laser Connection – AC-Coupled.....	49
8.4.	TX_Fault Circuit – Standalone Mode	50
9.	Packaging	52
10.	Contact Information.....	53

1. Ordering Information

Part Number	Description	Package
PHY1040-01QS-RE	VCSEL/LASER driver and Post Amp	QFN32, 5mmx5mm in Tape and Reel

2. Pin description

Pin No	Name	Direction	Type	Description
1	EEPROM_SDA	I/O	LVTTL	EEPROM 2 wire serial interface data, internal 8kΩ pull up
2	VDD_RXO		Power	Receiver output power supply
3	VSS_RXO		Ground	Receiver output ground connection
4	RXOUTM	O/P	CML	Limiting amplifier serial data output
5	RXOUTP	O/P	CML	Limiting amplifier serial data output
6	SDA	I/O	LVTTL	2-wire serial interface data
7	SCL	I/O	LVTTL	2-wire serial interface clock
8	IC			Internally connected, this pin must be left open circuit
9	TX_FAULT	O/P	LVTTL (Open Collector)	Laser fail alarm (requires external pull up)
10	TX_DISABLE	I/P	LVTTL	Laser enable / disable
11	TXINP	I/P	High Speed Input	Laser driver serial input, see section 7.0 for interfacing details
12	TXINM	I/P	High Speed Input	Laser driver serial input, see section 7.0 for interfacing details
13	VSS_IC			Internal connection, connect to ground
14	NC			No connection
15	NC			No connection
16	MPD	I/P	Analog	Monitor photodiode input
17	LVBIAS	O/P	Analog	Laser bias current output
18	LVMODE		Analog	Select VCSEL or Laser mode
19	VDD_TXO		Power	Driver output power supply
20	VSS_TXO		Ground	Driver output ground connection
21	LVOUTM	O/P	High speed Output	Laser/VCSEL driver serial output
22	LVOUTP	O/P	High speed Output	Laser/VCSEL driver serial output
23	VSS_TXO		Ground	Driver output ground connection
24	VDD_TXO		Power	Driver output power supply
25	IC			Internally connected, this pin must be left open circuit
26	SD/LOS	O/P	LVTTL (Open Collector)	Signal Detect or Loss of signal output (requires external pull up). Polarity selected by user
27	VSS_RX		Ground	Receiver ground connection

Pin No	Name	Direction	Type	Description
28	RXINM	I/P	CML	Limiting amplifier serial data input
29	RXINP	I/P	CML	Limiting amplifier serial data input
30	VSS_RX		Ground	Receiver ground connection
31	VDD_RX		Power	Receiver power supply
32	EEPROM_SCL	O/P	LVTTTL	EEPROM 2-wire serial interface clock, internal 8kΩ pull up
EP	VSS_EP		Ground	Common ground / thermal pad

3. Key Specifications

3.1. Absolute Maximum Ratings

Parameter	Conditions	Min	Typ	Max	Unit
Supply voltage		-0.5V		6.5	V
Voltage on any signal pin		-0.5		VDD + 0.5V	V
Storage temperature				150	°C
Max junction temperature				140	°C
Max soldering temperature	IPC/JEDEC J-STD-020C			260	°C
ESD	Human Body Model JESD-22-A114-B	2			kV

Device not guaranteed to meet specifications, permanent damage may be incurred by operating beyond these limits.

3.2. Continuous Ratings

Parameter	Conditions	Min	Typ	Max	Unit
Operating supply voltage	Continuous operation	2.97	3.3	3.63	V
Current consumption	Excluding bias & modulation current at 20mA bias & 20mA modulation		120	145	mA
Operating temperature	Ambient still air	-40	25	+95	°C

3.3. Transmitter

3.3.1. Transmitter Inputs: TXINP/M

Parameter	Conditions	Min	Typ	Max	Unit
Input Voltage	VILmin	1.14			V
	VIHmax			VDD_TX	V
Input Swing	Vpp(diff)	0.2www.jojwww			Vpp

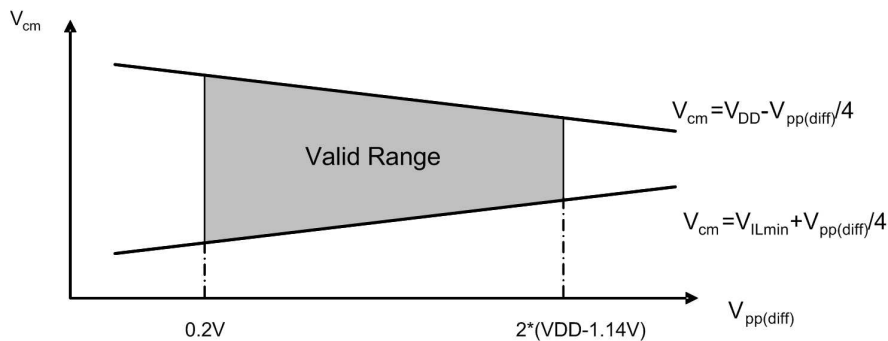

Figure 3 – Valid combinations of transmitter input voltages

3.3.2. VCSEL Driver

Parameter	Conditions	Min	Typ	Max	Unit
VCSEL output compliance range	Allowable voltage for pins LVOUTP/M in dynamic operation	900		VDD_TXO	mV
VCSEL bias current output compliance	Minimum allowed voltage for pin LV_BIAS, referenced to ground.	600			mV

3.3.3. VCSEL Bias ADC

Parameter	Description	Step Size and Resolution	Range
VCSEL I _{bias}	VCSEL bias current	0.102mA (+/- 0.05mA) 8 bits	1mA to 26mA

3.3.4. VCSEL Modulation DAC – High range setting

Parameter	Description	Step Size and Resolution	Range
VCSEL I _{mod}	Range of modulation current measured at LVOUT P/M (jitter within spec), subject to V _{vcsel_modH} and V _{vcsel_modL} levels	2mA < I _{bias} < 32mA = 125µA (±62.5µA) 8 bit referencing EEPROM lookup table	2mA to 32mA

3.3.5. VCSEL Modulation DAC – Low range setting

Parameter	Description	Step Size and Resolution	Range
VCSEL I _{mod}	Range of modulation current measured at LVOUT P/M (jitter within spec), subject to V _{vcsel_modH} and V _{vcsel_modL} levels	1mA < I _{bias} < 16mA = 62.7µA (±31.3µA) 8 bit referencing EEPROM lookup table	1mA to 16mA

3.3.6. Laser Driver

Parameter	Conditions	Min	Typ	Max	Unit
Maximum laser bias current		90			mA
Bias generator shutdown current	TX_DISABLE active			100	µA
Maximum laser modulation current		80			mA
Modulation generator shutdown current	TX_DISABLE active			100	µA
Electrical 20% to 80% rise / fall time	Measured using 15Ω effective termination, I _{mod} = 50mA, AC and DC applications		95		ps
Total jitter contribution	Measured over modulation current range			150	mUIp-p
Laser output compliance range	Allowed voltage for laser driver output pins in dynamic operation.	900		VDD_TXO	mV
Bias current output compliance	Minimum allowed voltage for pin BIAS, referenced to ground	600			mV
MPD input sink current	For correct APC loop operation			2.6	mA
MPD capacitance	For correct APC loop operation			20	pF

3.3.7. Laser Modulation DAC

Parameter	Description	Step Size and Resolution	DAC Range	Operational Range
IMOD_DAC	Modulation current DAC (8 bits)	0.375mA ($\pm 187\mu\text{A}$)	0 to 96mA	2mA to 80mA

3.3.8. Laser Bias ADC

Parameter	Description	Step Size and Resolution	DAC Range	Operational Range
IBIAS_ADC	Bias current ADC (8 bits)	0.588mA ($\pm 0.294\text{mA}$)	0 to 150mA	1mA to 90mA

3.3.9. Laser Bias DAC

Parameter	Description	Step Size and Resolution	DAC Range	Operational Range
IBIAS_DAC	Bias current DAC (8 bits)	0.392mA ($\pm 0.196\text{mA}$)	0 to 100mA	1mA to 90mA

3.3.10. Mean Power DAC

Parameter	Description	Step Size and Resolution	Operational Range
Imonset	Mean power DAC (8 bits).	MON_DAC $\leq 31 = 1.042\mu\text{A}$ ($\pm 0.5\mu\text{A}$) 32 \leq MON_DAC $\leq 127 = 4.167\mu\text{A}$ ($\pm 2\mu\text{A}$) MON_DAC $\geq 128 = 16.67\mu\text{A}$ ($\pm 8\mu\text{A}$)	0 to 2.55mA

3.4. Receiver

3.4.1. Receive Limiting Amplifier

Parameter	Conditions	Min	Typ	Max	Unit
Input sensitivity	1.25Gbps, PRBS 2 ⁷ -1, BER=1x10 ⁻¹²		6	8	mVp-p
System sensitivity	1.25Gbps, PRBS 2 ⁷ -1, BER=1x10 ⁻¹² With PHY1095 TIA PD Responsivity = 0.8A/W, PD Capacitance = 0.5pF		-32		dBm
Maximum differential input	TJ within spec	1200			mVp-p
Input termination impedance	Differential	80	100	120	Ω
Input common mode voltage			VDD_RX - 1.5		V
Input low frequency cutoff	High pass 3dB point for RX system		15		kHz
Differential output rise and fall times (20% - 80%)	Fast slew rate setting, 1250Mbps filter setting			100	ps
Differential output swing	CML_LEVEL = 0 CML_LEVEL = 1	700 370		900 470	mVp-p
Total jitter	Input voltage swing 30mVp-p, K28.5 pattern			200	mUIp-p
Output resistance	RXOUTP/M Single ended to VDD_RXO	40	50	60	Ω
Output return loss	Differential, f<2GHz, device powered on	10			dB
Rx 3dB frequency	125/155 Mbps setting 622 Mbps setting 1250 Mbps setting		120 470 940		MHz

3.4.2. OMA LOS

Parameter	Symbol	Conditions	Min	Typ	Max	Unit
OMA LOS assert time	t_{loss_on}				100	μ s
OMA LOS de-assert time	t_{loss_off}				20	μ s
Electrical hysteresis		$20\log_{10}(V_{deassert} / V_{assert})$ High setting Low setting		4 3		dB
OMA LOS assert level		Set by OMA_DAC, Address D9h	10		50	mV
Squelch assert time	$t_{squelch_on}$				100	μ s
Squelch de-assert time	$t_{squelch_off}$				20	μ s

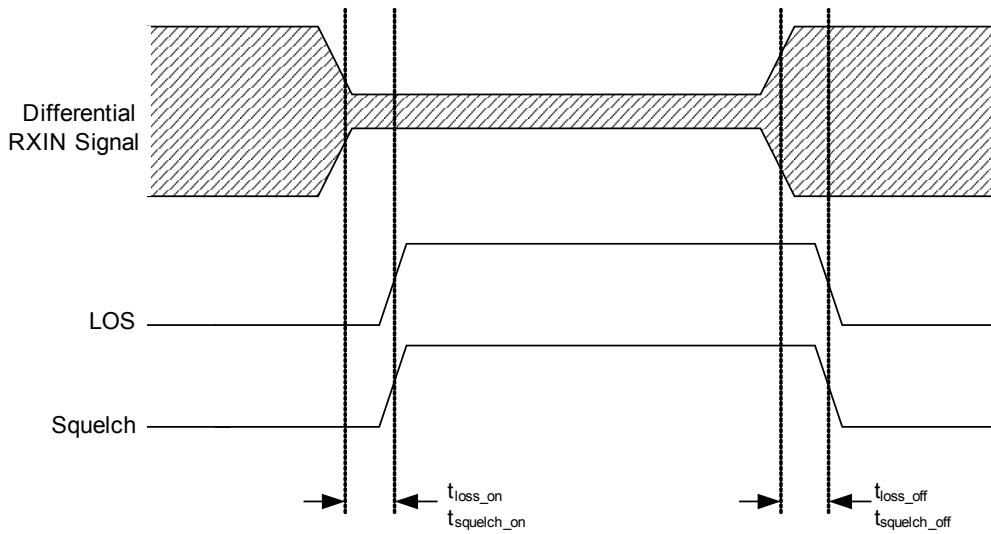

Figure 4 - OMA LOS Detection

3.4.3. LOS DAC

Parameter	Description	Step Size and Resolution	DAC Range	Range
OMA_DAC	OMA LOS DAC (8 bits)	250 μ V (\pm 125 μ V)	0 to 64mV	10mV to 50mV

3.4.4. Fault Timing

Parameter	Symbol	Condition	Min	Typ	Max	Unit
Time to initialize	t_{init}	From power on or application of VDD>2.97V during plug in			300	ms
Hard TX_DISABLE assert time	t_{off}	Time from rising edge of TX_DISABLE to when the optical output falls below 10% of nominal		5.5		μ s
Hard TX_DISABLE negate time	t_{on}	Time from falling edge of TX_DISABLE to when the modulated optical output rises above 90% of nominal			1	ms
Hard TX_FAULT assert time	t_{fault}	Time from fault to TX_FAULT on Bias/Temperature ADC outside safe range See section 8.4 for SFP/MSA compliant timing circuit.			10	ms
		All other fault conditions. See section 8.4 for SFP/MSA compliant timing circuit.			100	μ s
TX_DISABLE pulse width	t_{reset}	Time TX_DISABLE must be held high to reset TX_FAULT	5			μ s
TX_FAULT deassert time	$t_{faultdass}$	Time to deassert TX_FAULT after TX_DISABLE			300	ms

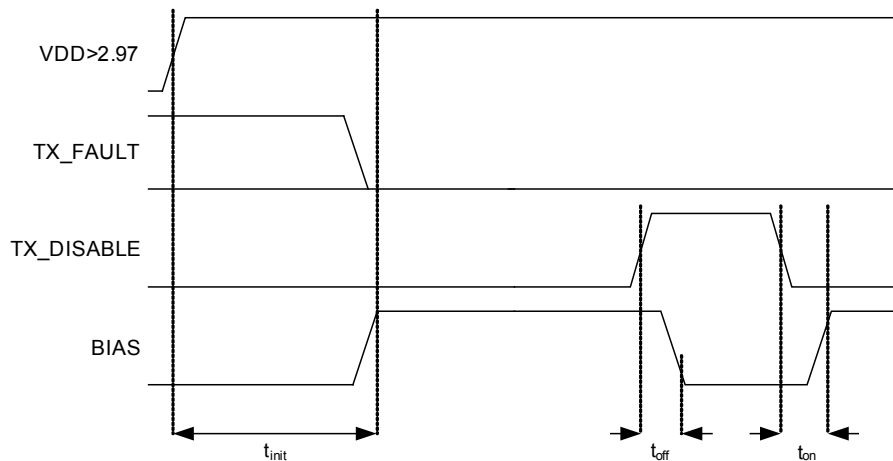

Figure 5 - Device turn on

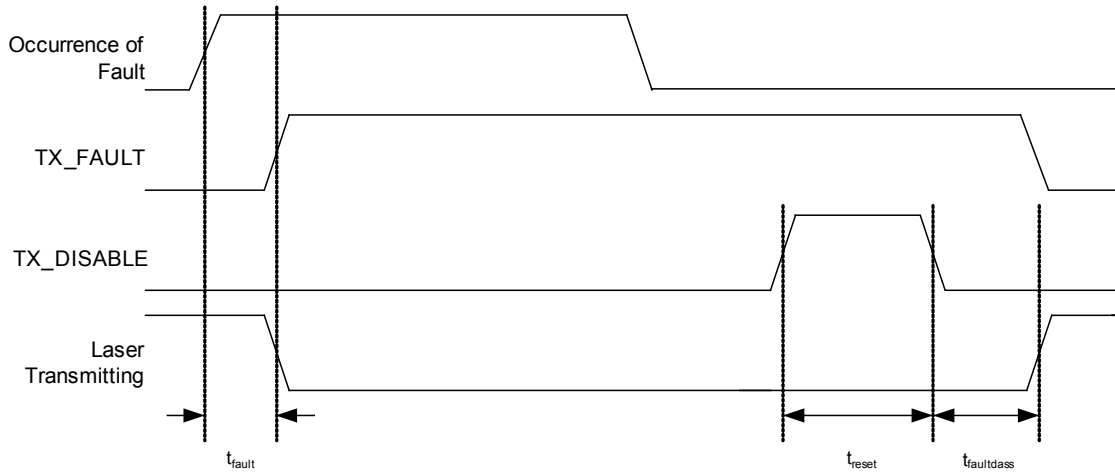

Figure 6 - Fault detection

3.4.5. Eye Safety Internal fixed limits

Parameter	Symbol	Comment	Min	Typ	Max	Unit
High supply voltage assert limit	V_{eyeHa}	Applies to VDD_TXO or VDD_TX	4.0	4.15	4.3	V
High supply voltage de-assert limit	V_{eyeHd}		3.7	3.85	4.0	V
Low supply voltage assert limit	V_{eyeLa}		2.45	2.6	2.75	V
Low supply voltage de-assert limit	V_{eyeLd}		2.7	2.8	2.95	V
High Supply Hysteresis			- 0.1			V
Low Supply Hysteresis			0.1			V

3.5. 2-Wire Serial Interface

3.5.1. AC Electrical Characteristics

Parameter	Symbol	Comment	Min	Typ	Max	Unit
SCL clock frequency	f_{SCL}		0		100	kHz
LOW period of the SCL clock	t_{LOW}		4.7			μs
HIGH period of the SCL clock	t_{HIGH}		4.0			μs
Set-up time for a repeated START condition	$t_{SU:STA}$		4.7			μs
Hold time (repeated) START condition	$t_{HD:STA}$		4.0			μs
Data hold time	$t_{HD:DAT}$		0		3.45	μs
Data set-up time	$t_{SU:DAT}$		250			ns
Rise time of both SDA and SCL signals	t_R				1000	ns
Fall time of both SDA and SCL signals	t_F				300	ns
Set-up time for STOP condition	$t_{SU:STO}$		4.0			μs
Bus free time between a STOP and START condition	t_{BUF}		4.7			μs
Output fall time from V_{IHmin} to V_{ILmax}	t_{of}	$10pF < C_b^{(1)} < 400pF$	0		250	ns
Capacitance for each I/O pin	C_i				10	pF

1: C_b = capacitance of a single bus line in pF.

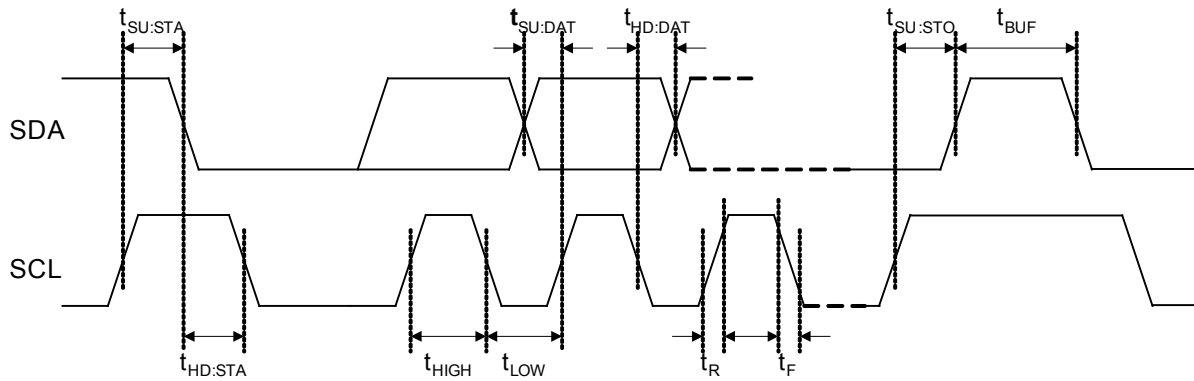

Figure 7 - SDA and SCL bus timing

3.5.2. DC Electrical Characteristics

Parameter	Symbol	Comment	Min	Typ	Max	Unit
Low level input voltage	V_{IL}		-0.5		0.3VDD	V
High level input voltage	V_{IH}		0.7VDD		VDD+0.5	V
Low level O/P voltage	V_{OL}	3 mA sink current	0		0.4	V
I/P current each I/O pin	I_i	$0.1V_{DD} < V_i < 0.9V_{DD}$	-10		10	mA

3.5.3. LVTTL I/O Pins ¹

Parameter	Comment	Min	Typ	Max	Unit
LVTTL voltage out high	External 4.7k to 10k pullup	2.4			V
LVTTL voltage out low	External 4.7k to 10k pullup			0.4	V
LVTTL voltage in high	Internal pullup	2.0		VDD – 0.2	V
LVTTL voltage in low	Internal pullup	0		0.8	V
Internal pull-up resistance	TX_DISABLE, EEPROM_SDA, EEPROM_SCL	6		10	k Ω

¹ Applies to LVTTL Pins specified on pages 3-4

4. Functional Description

4.1. Overview

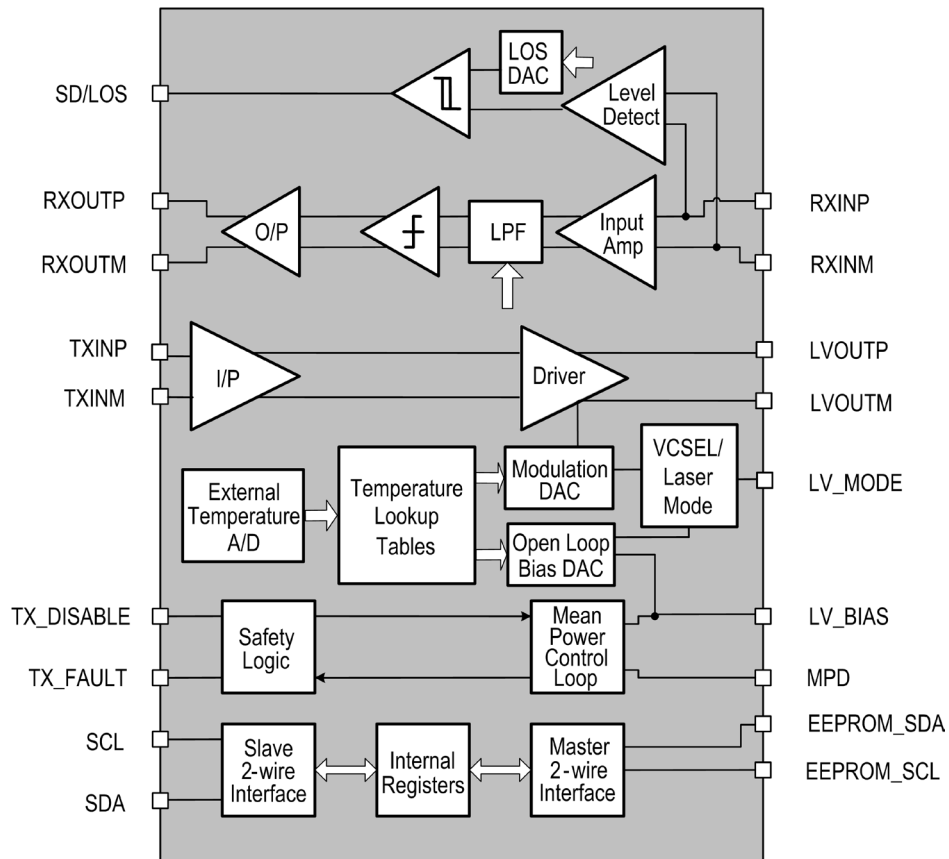

Figure 8 - PHY1040-01 Functional Overview

4.2. Transmitter features

The transmitter input buffer provides the necessary drive to the VCSEL/Laser driver output stage. It includes an internal high impedance bias network and is designed to be DC or AC-coupled. For high frequency applications an external termination network must be implemented.

The VCSEL/Laser driver output is designed to drive VCSEL/Lasers in the common anode configuration using either AC- or DC-coupling.

The laser driver circuit delivers a maximum peak to peak modulation current of 80mA measured at the device output pin LVOUTP. The VCSEL driver output stage provides 30mA max modulation drive and 20mA bias current.

By default the transmitter is non-inverting; however, to simplify the PCB layout of differential signals the polarity of the data can be inverted by setting TX_POLARITY (CAh, TX_DBUFF, bit 0) to '1'.

4.2.1. LVMODE

VCSEL or laser mode for PHY1040 is selectable by connecting the LVMODE pin high (laser) or low (VCSEL). LVMODE (ECh, LVMODE, bit 5) can be used to identify the logical level at this pin.

4.2.2. Modulation Current Control

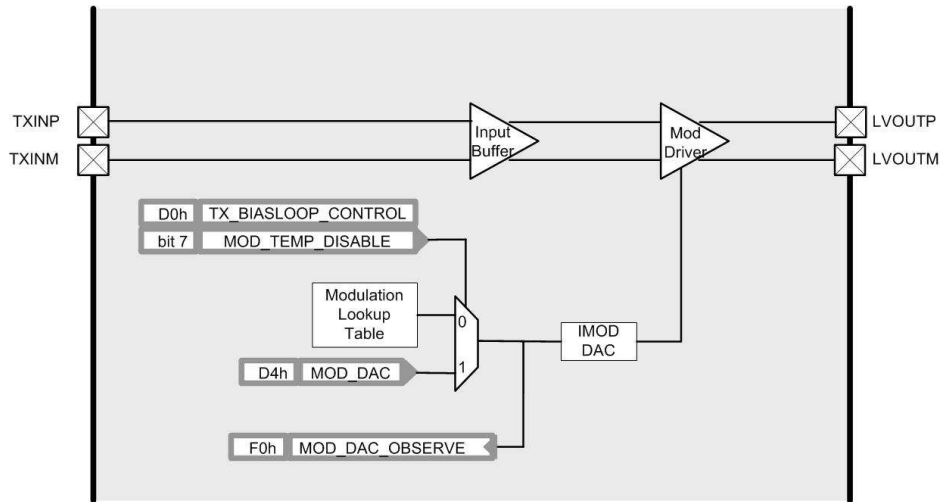

Figure 9 - Modulation Current Generation

The modulation current can be either set by a constant register value or controlled by a temperature indexed look-up table (LUT).

If MOD_TEMP_DISABLE is set to '1' (D0h, TX_BIASLOOP_CONTROL, bit 7) then the modulation DAC is set directly from a register (D4h, MOD_DAC).

If MOD_TEMP_DISABLE is set to '0' then a 64 byte LUT is used to set the modulation DAC. The LUT is indexed by the temperature ADC (E1h, TEMP_ADC_VALUE), where the index is given by:

$$\text{Index} = (\text{temperature ADC} \times 64) / 255.$$

The values of the LUT reside in the EEPROM, between addresses 80h (lowest temperature entry) and BFh (highest temperature entry), and are transferred at start up to on-chip registers.

The active setting for the modulation DAC can be observed by reading MOD_DAC_OBSERVE (F0h).

4.2.3. Bias Current Control

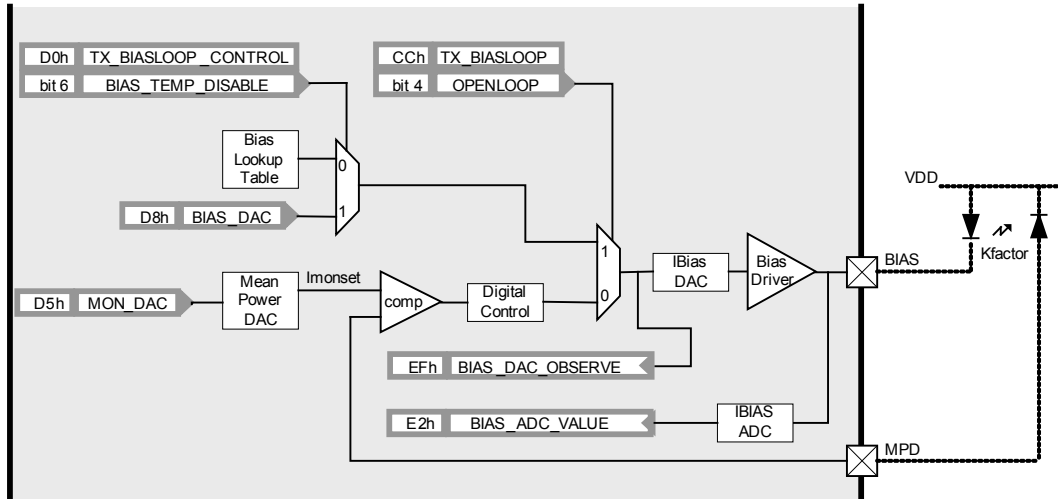

Figure 10 - Bias Current Generation

The PHY1040-01 can operate with open or closed loop bias control. In either mode the current setting for the bias DAC can be observed by reading BIAS_DAC_OBSERVE (EFh).

The actual bias current is measured using an on-chip ADC and can be observed by reading BIAS_ADC_VALUE (E2h).

In VCSEL mode a high (32mA) or low (16mA) bias DAC range can be selected using VMODRESOLUTION (CAh, VMODRESOLUTION, bit 1).

4.2.4. Open Loop

If OPENLOOP is set to '1' (CCh, TX_BIASLOOP, bit 4) the bias generator operates in open loop mode. The bias current can be either set by a constant register value or controlled by a temperature indexed lookup table (LUT).

If BIAS_TEMP_DISABLE is set to '1' (D0h, TX_BIASLOOP_CONTROL, bit 6) then the bias DAC is set directly from a register (D8h, BIAS_DAC).

If BIAS_TEMP_DISABLE is set to '0' then a 128 byte LUT is used to set the bias DAC. The LUT is indexed by the temperature ADC (E1h), where the index is given by:

$$\text{Index} = (\text{temperature ADC} \times 128) / 255.$$

The values for the LUT reside in the EEPROM, between addresses 00h (lowest temperature entry) and 7Fh (highest temperature entry), and are loaded into on-chip registers at start up.

In open loop mode the MPD device pin is not used and can be left unconnected.

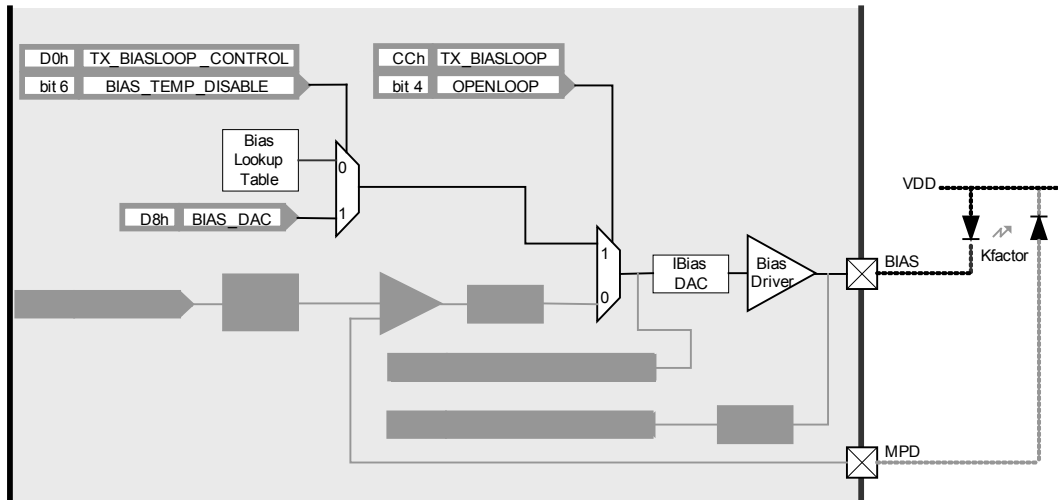

Figure 11 - Bias Current Generation, Open Loop

4.2.5. Closed Loop

If OPENLOOP is set to '0' the bias generator operates in closed loop mode. The average output power of the VCSEL/Laser is controlled by a digital mean power control loop. The feedback to the control loop is provided by a monitor photodiode connected to MPD. The current from the monitor photodiode is compared with a reference current (I_{monset}). This is output by the mean power DAC and controlled by MON_DAC (D5h).

In order to provide the required resolution and range the mean power DAC has three step sizes as shown in section 3.3.10.

The 3dB frequency of the digital mean power control loop is controlled by the size of a prescaling counter and can be determined (in Hertz) by:

$$F_{3dB} = (Kfactor \times 692) / (M \times I_{monset})$$

where Kfactor = VCSEL/Laser current to monitor photodiode current coupling coefficient

I_{monset} = desired monitor photodiode current (A)

$$M = 2^{(2 \times prescale_size)}$$

Prescale_size is set by (D0h, TX_BIASLOOP_CONTROL, bits 2:0).

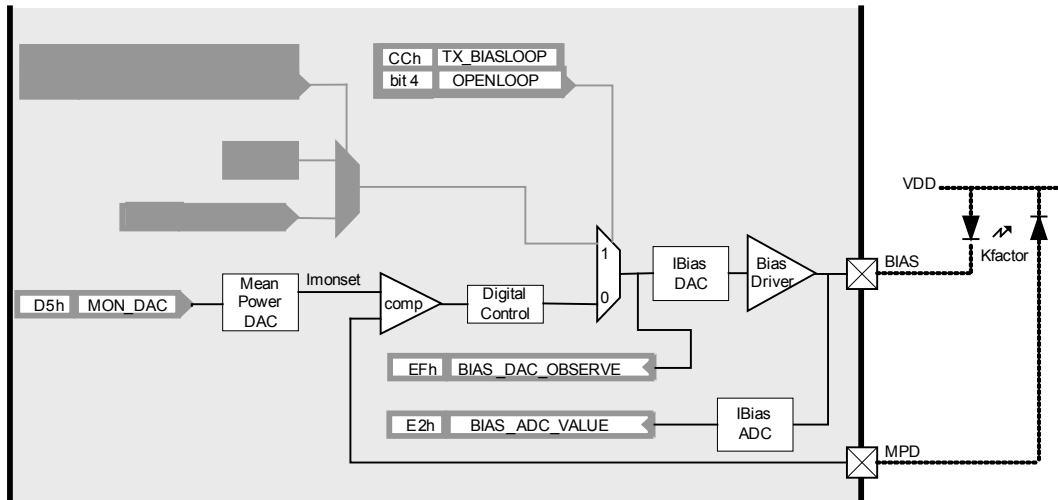

Figure 12 - Bias Current Generation, Closed Loop

4.2.6. Laser/VCSEL Eye Diagrams

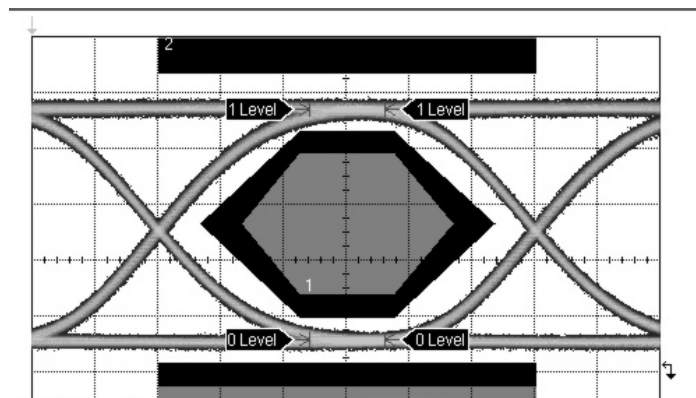

Figure 13 – VCSEL output 1.25 Gbps, PRBS7, -3 dBm average power, 25°C

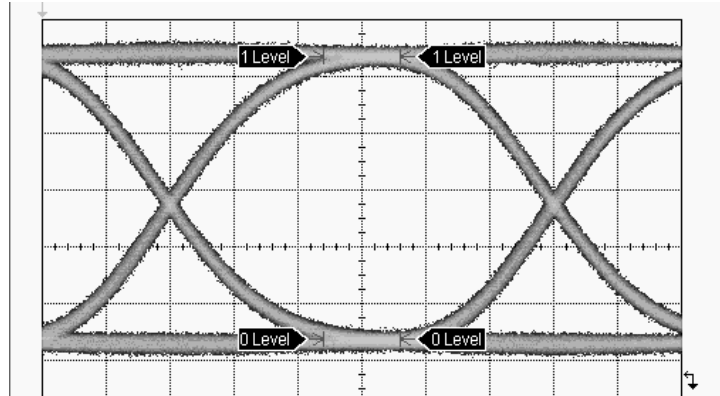

Figure 14 – LASER output 1.25 Gbps, PRBS7, -4 dBm output power, 25°C

4.2.7. Initial Start-up

At power up or after TX_DISABLE is de-asserted the PHY1040-01 can initialize within the time defined in the Small Form-factor Pluggable (SFP) MultiSource Agreement (MSA). See section 3.4.4 for initialization time.

4.2.8. VCSEL/Laser Driver Setup

There is a trimming network on the output driver which adjusts the time constant of the output damping on LVOUTM/P. It is controlled by the value in TX_DRIVER_CAP (C9h). Table 1 contains the valid register settings and the damping time constant they set, where RC = 16.8ps.

TX_DRIVE_CAP value	Time Constant
00h	0
01h	RC
02h	3RC
04h	5RC
08h	6RC
10h	7RC
20h	8RC

Table 1 - Time constant selection for the transmit output damping network

4.2.9. Performance Monitoring

As part of its main control loop the PHY1040-01 monitors temperature and transmit bias current via an on-chip ADC. The ADC values are reported via registers TEMP_ADC_VALUE (E1h) and BIAS_ADC_VALUE (E2h).

The user has the option of using the measured values of temperature and bias current to set alarm bits. These are generated if the values measured are above or below programmable limits. The conditions are shown in Table 2 and 3 below.

TEMP_MAX_ALARM_EN (DAh ALARM_EN bit 3)	TEMP_MIN_ALARM_EN (DAh ALARM_EN bit 2)	CONDITION	TEMP_MAX_ERROR (EAh bit 7)	TEMP_MIN_ERROR (EAh bit 6)
1	X	TEMP_ADC_VALUE > TEMP_MAX (DBh)	1	0
X	X	TEMP_MIN (DCh) < TEMP_ADC_VALUE < TEMP_MAX (DBh)	0	0
X	1	TEMP_ADC_VALUE < TEMP_MIN (DCh)	0	1
0	0	X	0	0

Table 2 - Over and under temperature alarm generation

BIAS_MAX_ALARM_EN (DAh ALARM_EN bit 1)	BIAS_MIN_ALARM_EN (DAh ALARM_EN bit 0)	CONDITION	BIAS_MAX_ERROR (EAh bit 5)	BIAS_MIN_ERROR (EAh bit 4)
1	X	BIAS_ADC_VALUE > BIAS_MAX (DDh)	1	0
X	X	BIAS_MIN (DEh) < BIAS_ADC_VALUE < BIAS_MAX (DDh)	0	0
X	1	BIAS_ADC_VALUE < BIAS_MIN (DEh)	0	1
0	0	X	0	0

Table 3 - Bias current alarm generation

An out of range monitored temperature (TEMP_MAX_ERROR is set to '1' or TEMP_MIN_ERROR is set to '1') will cause a TX_FAULT condition to be raised.

An out of range monitored bias current (BIAS_MAX_ERROR is set to '1' or BIAS_MIN_ERROR is set to '1') will cause a TX_FAULT condition to be raised.

The response of the PHY1040-01 to an alarm condition is described in Section 4.4.

4.3. Receiver Features

The PHY1040-01 receiver section consists of an Automatic Gain Control (AGC) input amplifier, which is followed by a programmable low pass filter. The filtered signal is passed to a limiting stage and the receiver output is a CML driver. Offset cancellation is provided by DC-feedback.

A Signal Detect (SD)/Loss Of Signal (LOS) alarm is provided to detect if the amplitude of the AC-signal at the receiver input is below a programmable threshold. For a transimpedance amplifier with a constant gain, the LOS threshold corresponds to a particular Optical Modulation Amplitude (OMA).

4.3.1. Receiver Input Stage

The receiver input stage includes internal 50Ω single-ended termination resistors and is designed to be AC-coupled to the transimpedance amplifier.

By default the receiver is non-inverting; however, to simplify the PCB layout of differential signals the polarity of the data can be inverted by setting RX_POLARITY (C3h, RX_LIMITER, bit 1) to '1'.

4.3.2. Receiver Filter

The programmable low pass filter provides band limiting in the receive signal path and can be used to improve the system sensitivity when a higher bandwidth TIA is used. The bandwidth of the filter is set to $0.7 \times$ signal data rate selected and is controlled by a 3-bit control word as follows:

Bit		Data Rate
1	0	
0	0	125/155Mbps
0	1	622Mbps
1	0	1063Mbps
1	1	1.25Gbps

Table 4 - Receive Filter Data Rates

The 2-bit control word is set in the RATE_SELECT register (C4h, RX_FILTER, bits 1:0).

4.3.3. Receiver CML Output Stage

The CML output stage has two slew rate settings, selected by CML_SLEW (C5h, RX_DRIVER, bit 1). The switching speed can be reduced in order to minimise electromagnetic radiation by setting CML_SLEW to a '1'. Setting CML_SLEW to '0' maximises the slew rate of the output.

The signal swing can also be adjusted. Setting CML_LEVEL to '0' (C5h, RX_DRIVER, bit 0) results in a higher receiver differential output swing. Setting CML_LEVEL to '1' results in a reduced output swing.

RXOUTP/M can also be disabled by setting RX_SQUELCH to a '1' (C2h, RX_AGC, bit 2).

The PHY1040-01 can automatically disable RXOUTP/M if a LOS condition is detected. To enable this function LOS_TO_SQUELCH should be set to '1' (C2h, RX_AGC, bit 3).

In both cases the output termination remains as 50Ω but a logical '0' is output on RXOUTP/M.

4.3.4. Loss of Signal

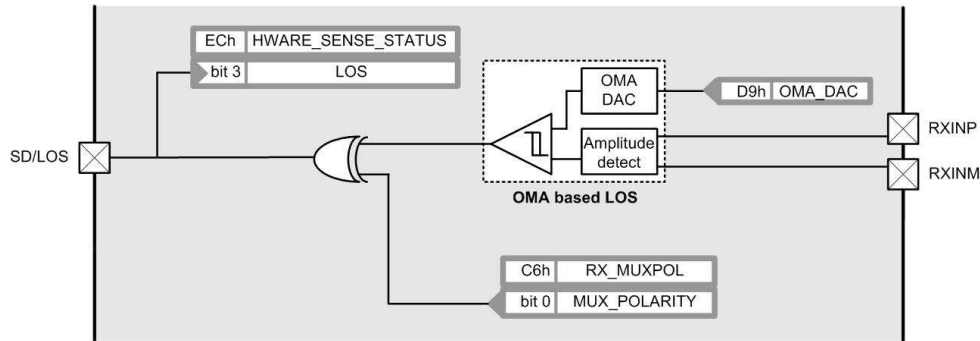

Figure 15 - LOS Detection

Signal Detect (SD) or Loss of Signal (LOS) is detected by measuring the optical modulation amplitude (OMA).

The signal amplitude measured at RXINP/M is compared to an analog threshold level set by the OMA_DAC register (D9h, OMA_DAC). If the received signal amplitude does not exceed the threshold then the LOS pin is asserted and the LOS indicator bit is set (ECh, HWARE_SENSE_STATUS, bit 3).

The polarity of the LOS pin and register indicator bit are controlled by MUX_POLARITY (C6h, RX_MUXPOL, bit 0). If MUX_POLARITY is set to '0' then the LOS pin is set high during a loss of signal condition. Conversely, if MUX_POLARITY is set to '1' then the LOS pin is set high when a signal is detected.

LOS detection has hysteresis, the level of which can be selected by OMAHYSTSEL (C6h, RX_MUXPOL, bit 1). If OMAHYSTSEL is set to '0' then 3dB of hysteresis is used. If OMAHYSTSEL is set to '1' then 4dB of hysteresis is used.

4.3.5. Voltage Reference

The PHY1040-01 includes a temperature stable 1V reference source which provides the bias for the internal analog circuitry. The reference voltage is set using an internal resistor and RINTERNAL (CEh, DAC_PWRD, bit 5) set to 1. The accuracy of the reference voltage using the internal resistor is +/-10%.

4.4. Laser/VCSEL Safety Features

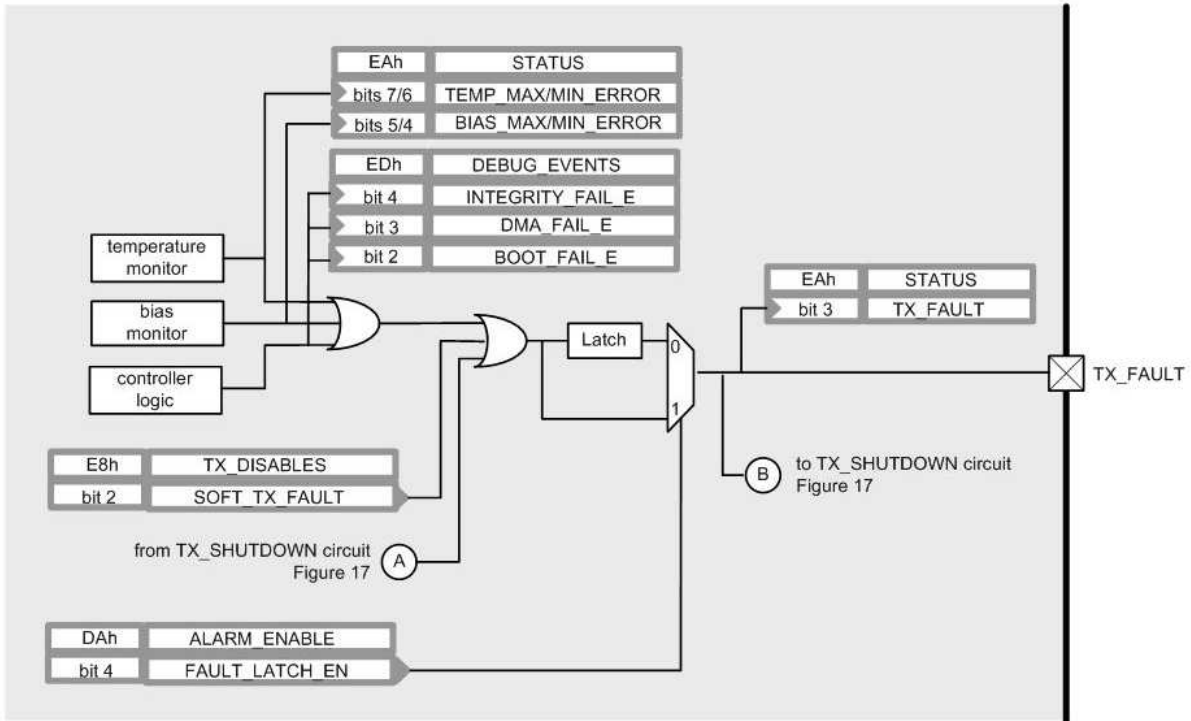

Figure 16 - Transmit Fault Generation

The VCSEL/Laser safety circuit monitors the device for potential faults. If a fault is detected the pin TX_FAULT is asserted. The register bit TX_FAULT (EAh, STATUS, bit 3) reflects the status of the pin TX_FAULT.

Using bias alarm requires FAULT_LATCH_ENABLE to be set to 0.

A transmit fault can be raised by the following:

1. The temperature monitor detects that the measured temperature has gone out of range.
2. The bias current monitor detects that the measured transmit bias current has gone out of range.
3. The internal controller logic detects that a DMA from EEPROM has failed (see section 5.1)
4. The SOFT_TX_FAULT bit (E8h, TX_DISABLES, bit 2) is set to '1'
5. The voltage reference monitoring circuit detects that the reference voltage is incorrect
6. The supply monitoring circuit detects that the power supply voltage is incorrect

If FAULT_LATCH_EN = '0' (DAh, ALARM_ENABLE, bit 4) then a transmit fault condition will cause the TX_FAULT pin to stay asserted even if the fault condition goes away. The pin will stay asserted until either the chip is power cycled or the pin TX_DISABLE is set to '1' or the register SOFT_TX_DISABLE is set to '1' (E8h, TX_DISABLES, bit 1) or FAULT_LATCH_EN is set to '1'.

If FAULT_LATCH_EN = '1' then the TX_FAULT pin is deasserted when the fault condition goes away.

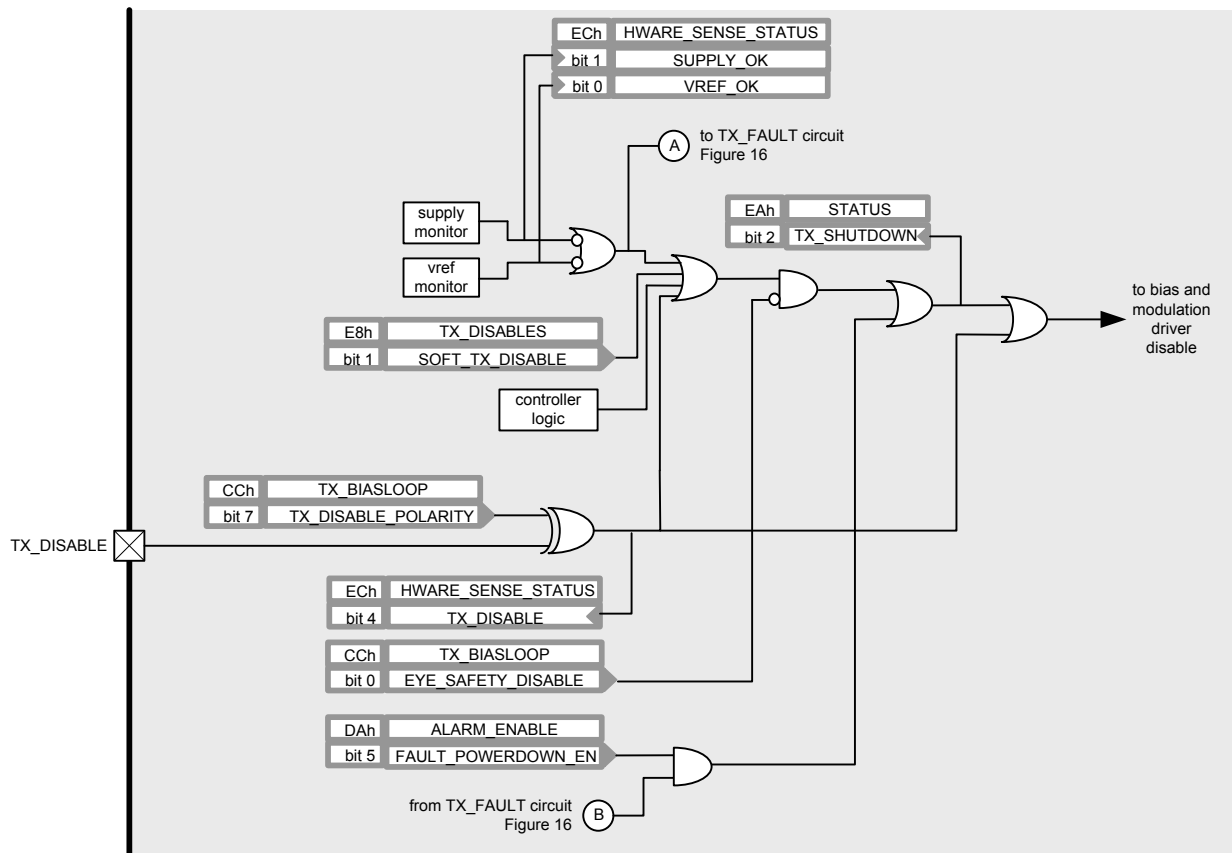

Figure 17 - Transmit Shutdown Generation

The PHY1040-01 contains circuitry to shutdown the transmitter bias and modulation current if a problem is detected. The circuit in section 8.4 is required to meet SFP MSA shutdown timing requirements. The conditions to cause a shutdown are:

1. The voltage reference monitoring circuit detects that the reference voltage is incorrect
2. The supply monitoring circuit detects that the power supply voltage is incorrect
3. The SOFT_TX_DISABLE bit (E8h, TX_DISABLES, bit 1) is set to '1'
4. The internal controller logic has not successfully completed its initialisation (see section 5.1)
5. The pin TX_DISABLE is asserted
6. TX_FAULT is active and FAULT_POWERDOWN_EN = '1' (DAh ALARM_EN bit 5)

If a shutdown condition occurs the modulation and bias currents are disabled. Conditions 1-4 can be disabled from contributing to shutdown by setting EYE_SAFETY_DISABLE = '1' (CCh, TX_BIASLOOP, bit 0). This feature should be used with great caution.

The polarity of the TX_DISABLE pin can be inverted by setting TX_DISABLE_POLARITY (CCh, TX_BIASLOOP, bit 7).

The register bit TX_SHUTDOWN (EAh, STATUS, bit 2) reflects the status of the shutdown circuit.

The register bit TX_DISABLE (ECh, HWARE_SENSE_STATUS, bit 4) reflects the status of the pin TX_DISABLE (after optional inversion using TX_DISABLE_POLARITY).

Pin No	Name	Circuit response to over voltage or short to Vcc	Circuit response to under voltage or short to ground
1	EEPROM_SDA	Does not affect VCSEL/laser power	Does not affect VCSEL/laser power
4	RXOUTM	Does not affect VCSEL/laser power	Does not affect VCSEL/laser power
5	RXOUTP	Does not affect VCSEL/laser power	Does not affect VCSEL/laser power
6	SDA	Does not affect VCSEL/laser power	Does not affect VCSEL/laser power
7	SCL	Does not affect VCSEL/laser power	Does not affect VCSEL/laser power
9	TX_FAULT	Does not affect VCSEL/laser power	Does not affect VCSEL/laser power
10	TX_DISABLE	Modulation and bias currents are disabled	Normal condition for circuit operation
11	TXINP	Does not affect VCSEL/laser power	Does not affect VCSEL/laser power
12	TXINM	Does not affect VCSEL/laser power	Does not affect VCSEL/laser power
16	MPD	The APC circuit responds by increasing the bias current until a fault is detected; then a fault states occurs.	The APC circuit responds by increasing the bias current until a fault is detected; then a fault states occurs.
17	BIAS	The laser forward voltage is 0V and no light is emitted	Fault state occurs
21	LVOUTM	Bias current increases until a fault is detected; then a fault state occurs (DC coupled system)	Fault state occurs (DC coupled system)
22	LVOUTP	Does not affect VCSEL/laser power (DC coupled system)	Does not affect VCSEL/laser power (DC coupled system)
26	SD/LOS	Does not affect laser power	Does not affect laser power
28	RXINM	Does not affect laser power	Does not affect laser power
29	RXINP	Does not affect laser power	Does not affect laser power
32	EEPROM_SCL	Does not affect laser power	Does not affect laser power

Figure 18 - Circuit Response to Single Point Fail Conditions

4.5. Temperature Measurement

The PHY1040-01 uses an on-chip 8 bit ADC to perform a temperature measurement once per iteration of its main control loop (approximately every 10ms). The measured ADC value can be read from register TEMP_ADC_VALUE (E1h). This measurement can be used to control the modulation and bias currents.

The temperature is determined by forcing two different currents through a diode connected transistor (base and collector shorted together) measuring the resulting voltage difference, ΔV_{BE} . This voltage is directly proportional to the temperature.

SELECT_3I (CBh, TX_TEMPSENSE, bit 0) and VTOISLOPESEL (CBh, TX_TEMPSENSE, bits 2 - 3) can be adjusted to ensure that the PHY1040-01 is capable of measuring the required range of temperatures.

The temperature sensor operating range is shown in Table 5.

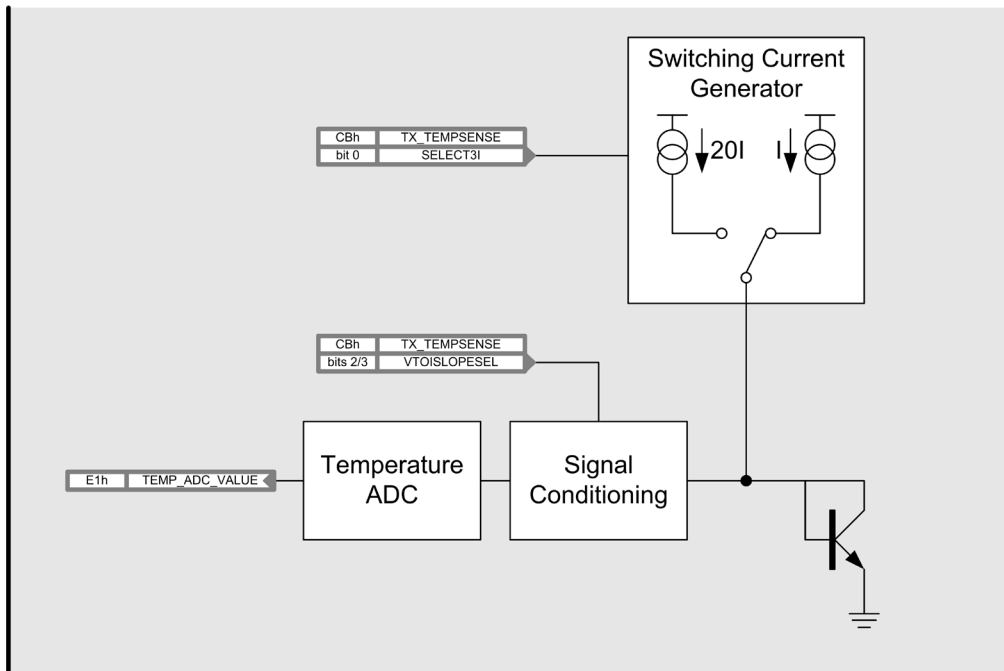

Figure 19 – Temperature sensor functional block diagram

Parameter	Comment	Symbol	Min	Typical	Max	Units
Temperature		T	-45		90	°C
ADC slope	VTOISLOPESEL = 00			0.79		°C/bit
	VTOISLOPESEL = 01			0.5		°C/bit
	VTOISLOPESEL = 10			0.417		°C/bit
	VTOISLOPESEL = 11			0.294		°C/bit

Table 5 - Temperature Measurement

5. Control Interface

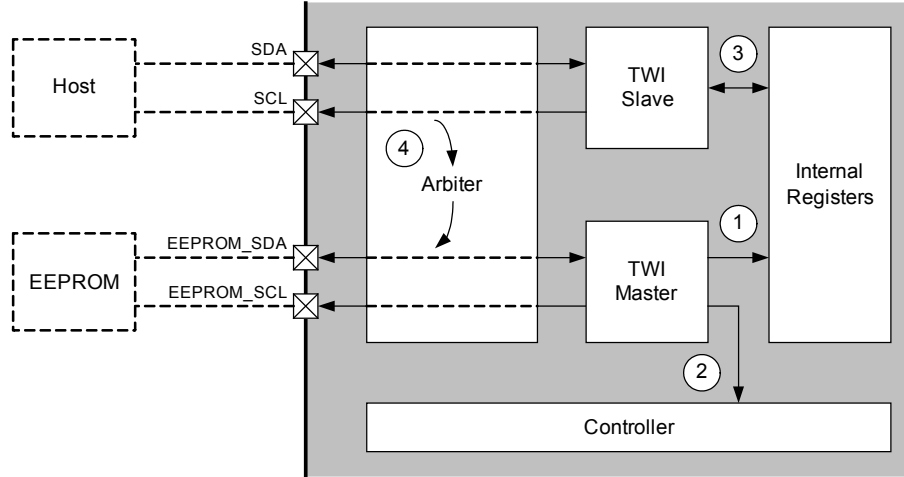

Figure 20 - Serial interfaces to internal registers

The host communicates with the PHY1040-01 and the EEPROM via the slave Two Wire Interface (TWI) pins of the PHY1040-01. Slave addresses A0h and A2h are supported. If a transaction arriving at the slave interface is addressed to A2h, then the PHY1040-01 examines the register address in order to decide how the transaction should be processed (see address map in figure 21).

- If the register is implemented in EEPROM only (addresses 00h to BFh) then the transaction is forwarded to the EEPROM via path 4 in figure 20. There is a direct combinational logic path between the slave and master interfaces which makes the PHY1040-01 transparent when transactions from the host are forwarded to the EEPROM.
- If the register is only implemented internally to the PHY1040-01 (addresses E0h to FFh) then the data is written to or read from the registers inside the PHY1040-01 (path 3).
- If the register is implemented both internally and EEPROM (addresses C0h to DFh) then the PHY1040-01 checks the INTERNAL_ACCESS register bit (E7h INTERNAL bit 1) to determine whether the host wishes to access the EEPROM or internal registers. Set INTERNAL_ACCESS is set to '1' to access the internal registers and '0' to access the EEPROM.

When the PHY1040-01 comes out of reset, the state machine uses the master two wire interface to read configuration bytes out of EEPROM. This data is used to configure the internal registers of the device (path 1).

Subsequently, during normal operation the state machine will use the master interface to periodically access look-up table and alarm threshold information stored in the EEPROM (path 2). In order to prevent collisions between state machine and host accesses to EEPROM, the host must always stop the state machine before attempting to access the EEPROM by setting an internal register bit, SM_STOP, to '1' (E7h, INTERNAL, bit 0). When the host has completed its transactions with the EEPROM it must set SM_STOP to '0' to allow normal operation of the state machine to resume. If the host attempts to access the EEPROM when SM_STOP is set to '0' then writes are ignored and reads return a zero.

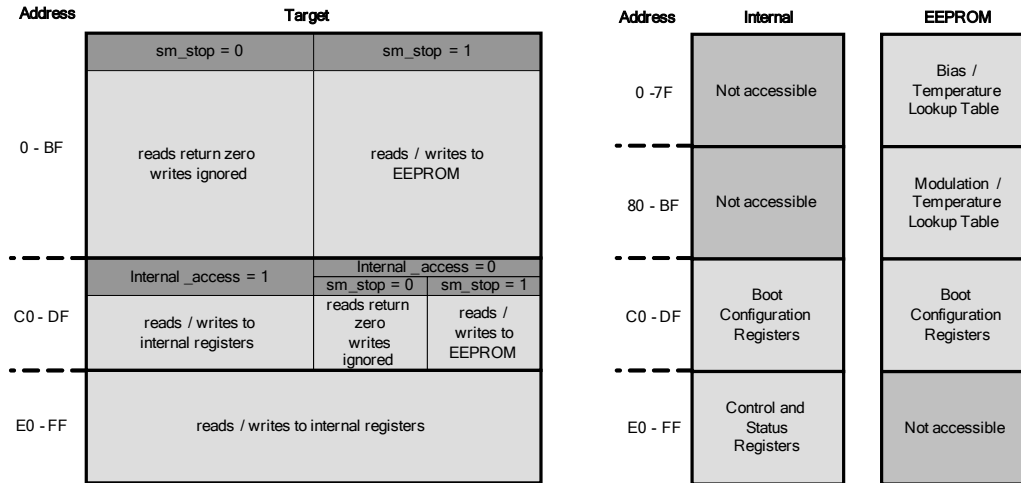

Figure 21 - PHY1040-01 TWI Slave Accesses

5.1. Boot Sequence

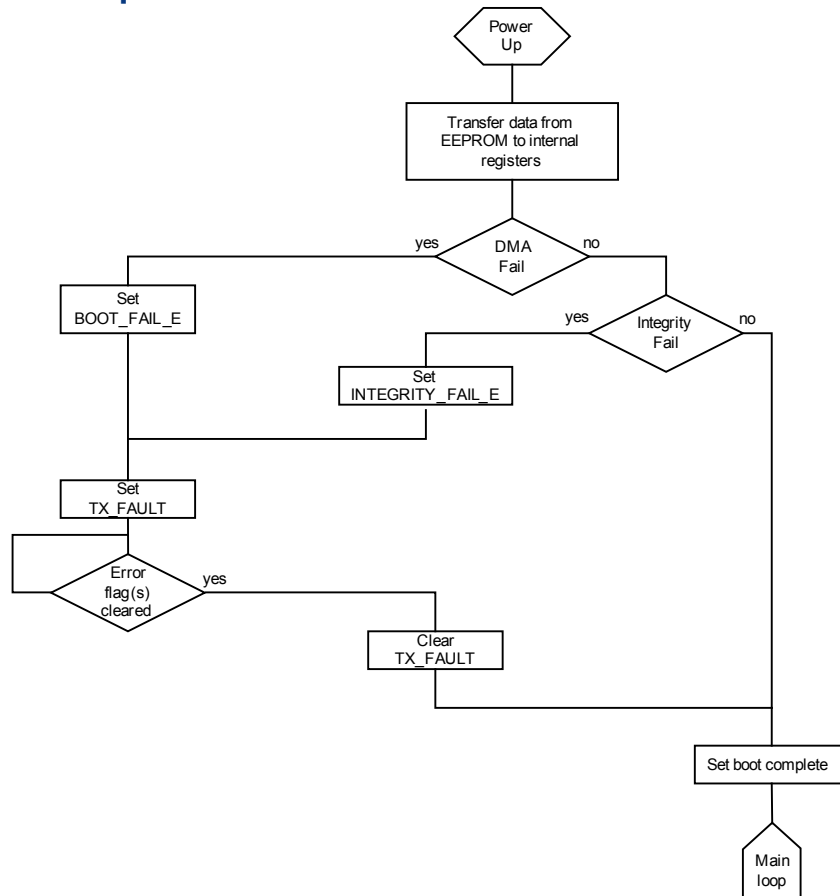

Figure 22 - PHY1040-01 Boot Sequence

At power up the PHY1040-01 attempts to read a number of bytes of configuration information from an external EEPROM into its internal registers.

If the read fails due to a problem on the TWI, such as a read not being correctly acknowledged, the state machine sets register bit `BOOT_FAIL_E` to '1' (EDh, `DEBUG_EVENTS`, bit 2), raises a transmit fault condition and remains in an error state.

The first two bytes read from EEPROM, C0h and C1h, are compared against a data integrity number (C35Ah). If the compare fails, the state machine sets register bit `INTEGRITY_FAIL_E` to '1' (EDh, `DEBUG_EVENTS`, bit 4), raises a transmit fault condition and remains in an error state.

In the error state the host is able to configure the internal registers of the PHY1040-01 using the slave TWI. When it has completed configuration the host must clear the active error(s) by writing a '1' to the corresponding bit(s). When the state machine sees that the error bit(s) are cleared it clears the transmit fault condition.

The state machine sets the register `BOOT_COMPLETE_E` (EDh, `DEBUG_EVENTS`, bit 1) to indicate that the boot process is complete and then enters the main control loop.

5.2. Main Control Loop

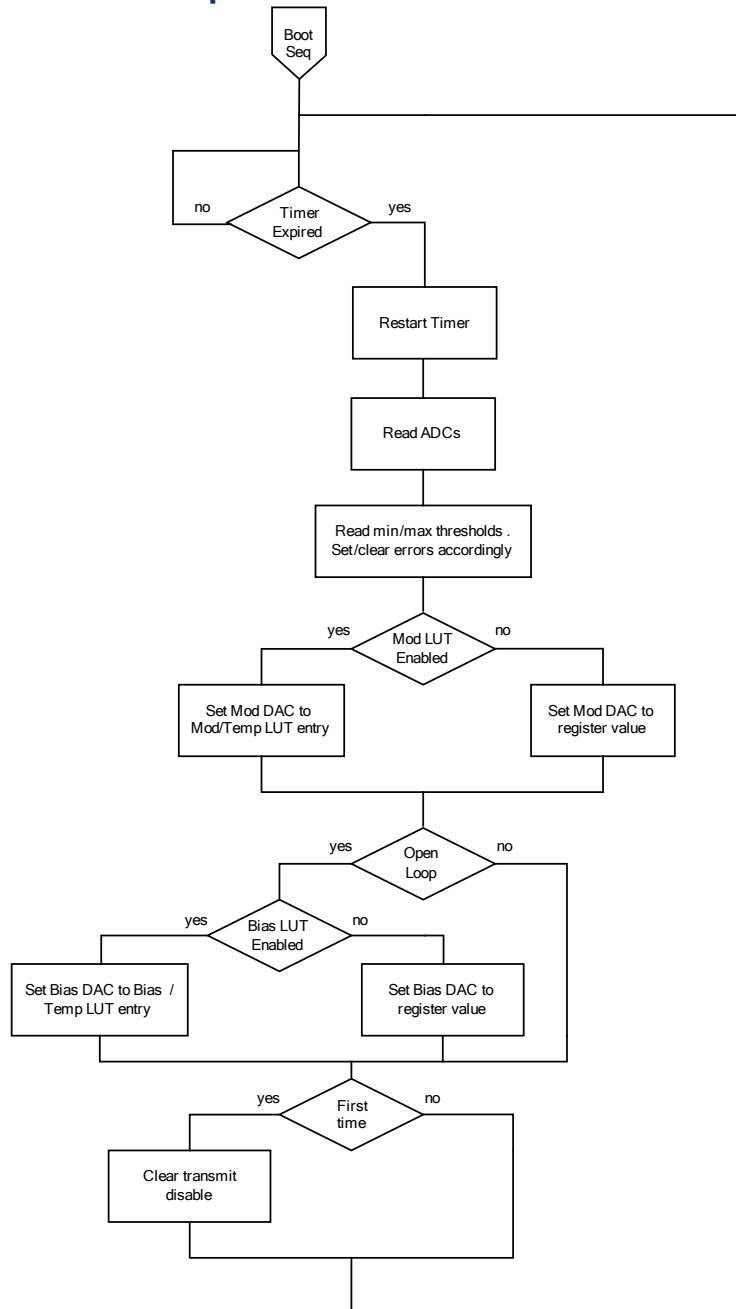

Figure 23 - PHY1040-01 Main Loop Function

A loop timer is implemented in the state machine to ensure that the start of each iteration of the loop is separated by 10ms.

When the timer has expired the state machine reads the on-chip ADC to obtain temperature and bias current levels, reads alarm levels out of EEPROM and sets/clears performance alarms accordingly.

The state machine then sets the modulation current and bias current.

At the end of the first iteration of the loop after boot-up the state machine clears transmit disable to enable the transmit data path.

5.3. 2-wire Serial Interface

The PHY1040-01 has a pair of 2-wire serial interfaces: a slave for interfacing to a host for module setup and programming, and a master for interfacing to an external EEPROM and for device configuration after reset. Both interfaces communicate using the protocol described in this section.

5.3.1. Framing and Data Transfer

The two-wire interface comprises a clock line (SCL) and a data line (SDA). When the bus is idle both are pulled high within the PHY1040-01 by 8kΩ pull-ups.

An individual transaction is framed by a start condition and a stop condition. A start condition occurs when a bus master pulls SDA low while the clock is high. A stop condition occurs when the bus master allows SDA to transition low-to-high when the clock is high. Within the frame, the master has exclusive control of the bus. The PHY1040-01 supports REPEAT START conditions whereby the master may simultaneously end one frame and start another without releasing the bus by replacing the STOP condition with a START condition.

Within a frame, the state of SDA may only change when SCL is low. A data bit is transferred on a low-to-high transition of SCL. Data is arranged in packets of 9 bits. The first 8 bits represent data to be transferred (most significant bit first). The last bit is an acknowledge bit. The recipient of the data holds SDA low during the ninth clock cycle of a data packet to acknowledge (ACK) the byte. Leaving SDA to float high on the ninth bit signals a not-acknowledged (NACK) condition. The interpretation of the acknowledge bit by the sender will depend on the type of transaction and the nature of the byte being received.

5.3.2. Device Addressing

The first byte to be sent after a START condition is an address byte. The first seven bits of the byte contain the target slave address (msb first). The eighth bit indicates the transaction type – ‘0’ = write, ‘1’ = read. Each slave interface on the bus is assigned a 7-bit slave address. If no slave matches the address broadcast by the master then SDA will be left to float high during the acknowledge bit and the master receives a NACK. The master must then assert a STOP condition. If a slave identifies the address then it acknowledges the master and proceeds with the transaction identified by the type bit.

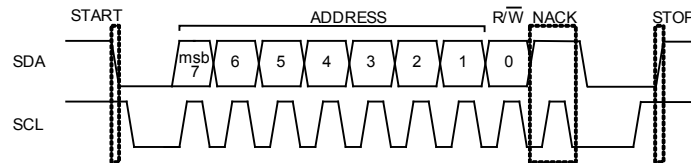

Figure 24 - Address decoding example – slave not available

5.3.3. Write Transaction

Figure 25 shows an example of a write transaction. The address byte is successfully acknowledged by the slave, and the type bit is set low to signify a write transaction. After the acknowledge the master sends a single data byte. All signalling is controlled by the master except for the SDA line during the acknowledge bits. During the acknowledge the direction of the SDA line is reversed and the slave pulls SDA low to return a ‘0’ (ACK) to the master.

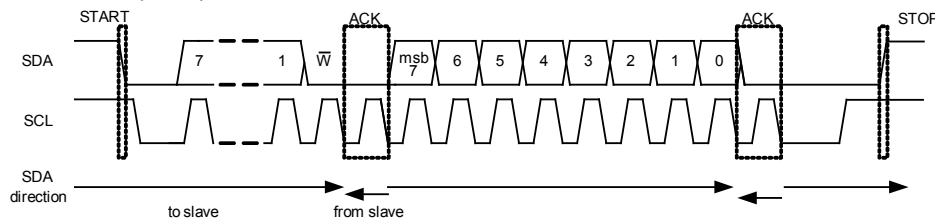

Figure 25 - Write transaction

If the slave is unable to receive data then it should return a NACK after the data byte. This will cause the master to issue a STOP and thus terminate the transaction.

The PHY1040-01 interprets the first data byte as a register address. This will be used to set an internal memory pointer. Subsequent data bytes within the same transaction will then be written to the memory location addressed by the pointer. The pointer is auto-incremented after each byte. There is no limit to the number of bytes which may be written to the internal RAM of the PHY1040-01. If, however, the write access is destined for the EEPROM the requirements of page writes specified for the EEPROM apply.

If the slave is not ready to receive a byte then it may hold SCL low immediately after the acknowledge bit. When SCL is released the master starts to send the next byte. This is known as clock stretching. The PHY1040-01 slave interface will not clock stretch at up to 100 kHz SCL frequency.

5.3.4. Read Transaction

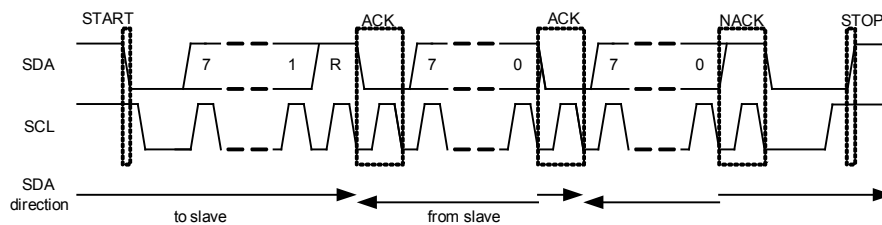

Figure 26 - Read transaction

Figure 26 shows an example of a 2 byte read transaction. The address byte is successfully acknowledged by the slave, and the type bit is set high to signify a read. After the ACK the slave returns a byte from the location identified by the internal memory pointer. This pointer is then auto-incremented. The slave then releases SDA so that the master can ACK the byte. If the slave receives an ACK then it will send another byte. The master identifies the last byte by sending a NACK to the slave. The master then issues a STOP to terminate the transaction.

Thus, to implement a random access read transaction, a write must first be issued by the master containing a slave address byte and a single data byte (the register address) as shown in Figure 25. This sets up the memory pointer. A read is then sent to retrieve data from this address (see Figure 26).

6. Register Map

Where a single power-on reset (PoR) value is shown for a range of addresses, that value applies to all bytes in the range. Note that the power on reset values may be overwritten during initialisation from the EEPROM.

For registers containing a single 8-bit field, the most significant bit of the field is stored in bit 7 of the register byte.

Note that 'reserved' or 'internal use only' register bits are specified as read only. These registers should not be changed from their PoR default settings.

R Bit is read only. A write to this bit via the TWI will have no effect. The value may be changed by the device itself as part of its normal operation

R/W Bit is readable and writable via the TWI. The value will not be changed by the device itself except under a device reset.

E Bit is readable via the TWI. The bit may be set by the device itself as part of its normal operation. Once set the bit may be cleared by writing a '1' via the TWI. Writing a '0' via the TWI has no effect.

C0h	DATA_INTEGRITY_LOWER			Integrity check for EEPROM contents. Must be set to C3h for a boot load from EEPROM to be successful. Note, this register exists only in EEPROM and not in the internal registers of the device, therefore a write to this address when 'INTERNAL_ACCESS' is set high will be ignored and a read return zero.
Type	R/W	PoR	00h	

C1h	DATA_INTEGRITY_UPPER			Integrity check for EEPROM contents. Must be set to 5Ah for a boot load from EEPROM to be successful. Note, this register exists only in EEPROM and not in the internal registers of the device, therefore a write to this address when 'INTERNAL_ACCESS' is set high will be ignored and a read return zero.
Type	R/W	PoR	00h	

C2h	RX_AGC			This register controls functions in the AGC in the receive path of the device
Bit	Field name	Type	PoR	
7	-	R	0	reserved
6	-	R	0	reserved
5	-	R	0	reserved
4	-	R	0	reserved
3	LOS_TO_SQUELCH	R/W	0	Setting this bit to a '1' connects the LOS function to the receiver squelch such that a LOS will automatically disable the receiver output
2	RX_SQUELCH	R/W	0	Setting this bit to a '1' causes the receiver output to be disabled
1	-	R/W	0	Internal use only. Must be set to '0'
0	-	R/W	0	Internal use only. Must be set to '0'

C3h		RX_LIMITER		This register controls functions in the limiter in the receive path of the device
Bit	Field name	Type	PoR	
7	-	R	0	reserved
6	-	R	0	reserved
5	-	R	0	reserved
4	-	R	0	reserved
3	-	R	0	reserved
2	-	R/W	0	Internal use only. Must be set to '0'
1	RX_POLARITY	R/W	0	Setting this bit to a '1' causes the receive output polarity to be inverted
0	-	R/W	0	Internal use only. Must be set to '0'

C4h		RX_FILTER		This register controls functions in the filter in the receive path of the device
Bit	Field name	Type	PoR	
7	-	R	0	reserved
6	-	R	0	reserved
5	-	R	0	reserved
4	-	R	0	reserved
3	-	R/W	0	Internal use only. Must be set to '0'
2	-	R/W	0	reserved
1	RATE_SELECT(1)	R/W	0	Selects the filter rate in the receiver '00' = 155 Mbps '01' = 622 Mbps
0	RATE_SELECT(0)	R/W	0	'10' = 1063Mbps '11' = 1250 Mbps

C5h		RX_DRIVER		This register controls functions in the output driver in the receive path of the device
Bit	Field name	Type	PoR	
7	-	R	0	reserved
6	-	R	0	reserved
5	-	R	0	reserved
4	-	R	0	reserved
3	-	R	0	reserved
2	-	R	0	reserved
1	CML_SLEW	R/W	0	Sets the receiver output slew rate '1' = slow '0' = fast
0	CML_LEVEL	R/W	0	Sets the receiver output swing level '1' = low swing '0' = high swing

C6h		RX_MUXPOL		This register controls the loss of signal detection circuit in the receive path of the device
Bit	Field name	Type	PoR	
7	-	R	0	reserved
6	-	R	0	reserved
5	-	R	0	reserved
4	-	R	0	reserved
3	-	R	0	reserved
2	-	R	0	reserved
1	OMAHYSTSEL	R/W	0	Sets the amount of hysteresis in the LOS detection circuit '1' = 4 dB of hysteresis '0' = 3 dB of hysteresis
0	MUX_POLARITY	R/W	0	Sets the polarity of LOS output pin '1' = Pin is high when signal detect '0' = Pin is high when loss of signal

C7h		TEST0		Internal use only, must be set to 00h
Type	R/W	PoR	00h	

C8h		TEST1		Internal use only, must be set to 00h
Type	R/W	PoR	00h	

C9h		TX_DRIVER_CAP		This register allows selective snubbing capacitors to be applied to the transmit output stage. Setting the register to 0h applies no damping.
Type	R/W	PoR	00h	

CAh		TX_DBUFF		This register controls functions in the data buffer in the transmit path of the device
Bit	Field name	Type	PoR	
7	-	R	0	reserved
6	-	R	0	reserved
5	-	R	0	reserved
4	-	R/W	0	Internal use only, must be set to 00h
3	-	R/W	0	
2	-			
1	VMODRESOLUTION	R/W	0	Control over VCSEL mode modulation current and resolution, 16mA/32mA select
0	TX_POLARITY	R/W	0	Setting this bit to a '1' causes the transmit output polarity to be inverted

CBh	TX_TEMPSENSE			This register controls functions associated with the device temperature measurement
Bit	Field name	Type	PoR	
7	-	R	0	reserved
6	-	R	0	reserved
5	-	R	0	reserved
4	-	R	0	reserved
3	VTOISLOPESEL(1)	R/W	0	This field modifies the expected slope from the temperature sensor into the ADC and should be set depending on the type of external temperature sensor
2	VTOISLOPESEL(0)	R/W	0	
1	RESERVED	R/W	0	Internal use only. Must be set to '1'
0	SELECT_3I	R/W	0	Setting this bit to '1' causes the temperature sensor to operate at 3 times the default measurement current.

CCh	TX_BIASLOOP			This register controls functions in the bias current generator in the transmit path of the device
Bit	Field name	Type	PoR	
7	TX_DISABLE_POLARITY	R/W	0	Setting this bit to a '1' inverts the polarity of the TX_DISABLE input pin
6	-	R/W	0	Internal use only. Must be set to '0'
5	-	R/W	0	Internal use only. Must be set to '0'
4	OPENLOOP	R/W	0	Sets the configuration of the transmit bias circuit '1' = open loop '0' = closed loop
3	-	R/W	0	Internal use only. Must be set to '0'
2	-	R/W	0	Internal use only. Must be set to '0'
1	-	R/W	0	Internal use only. Must be set to '0'
0	RESERVED	R/W	0	Set to '0' during operation of the device

CDh	TEST2			Internal use only, must be set to 00h
Type	R/W	PoR	00h	

CEh		DAC_PWRD		
Bit	Field name	Type	PoR	
7	-	R	0	reserved
6	-	R	0	reserved
5	RINTERNAL	R/W	0	Set to '1', an internal 10kΩ resistor is used for generating the reference voltage.
4	-	R/W	0	Internal use only, must be set to 0
3	-	R/W	0	Internal use only, must be set to 0
2	-	R/W	0	Internal use only, must be set to 0
1	-	R/W	0	Internal use only, must be set to 0
0	-	R/W	0	Internal use only, must be set to 0

CFh		TEST3		Internal use only, must be set to 00h
Type	R/W	PoR	00h	

D0h		TX_BIASLOOP_CONTROL		This register controls generation of the transmit bias current
Bit	Field name	Type	PoR	
7	MOD_TEMP_DISABLE	R/W	0	Setting this bit to '1' disables the modulation current / temperature lookup table
6	BIAS_TEMP_DISABLE	R/W	0	In open loop mode setting this bit to '1' disables the bias current / temperature lookup table. In closed loop mode it has no effect
5	RESERVED	R/W	0	Internal use only, must be set to 0
4	RESERVED	R/W	0	Internal use only, must be set to 0
3	RESERVED	R/W	0	Internal use only, must be set to 1
2	PRESCALE_SIZE(2)	R/W	0	These bits configure the loop bandwidth of the closed loop bias current. See section 4.2.5 for further details
1	PRESCALE_SIZE(1)	R/W	0	
0	PRESCALE_SIZE(0)	R/W	0	

D1h	Test4				Internal use only, must be set to 00h
Type	R/W	PoR	00h		
D2h	Test5				Internal use only, must be set to 00h
Type	R/W	PoR	00h		
D3h	VREF_DAC				Reference voltage trim DAC Set to 71h
Type	R/W	PoR	00h		
D4h	MOD_DAC				Sets the modulation current (via a DAC) when the Modulation / Temperature LUT is disabled (MOD_TEMP_DISABLE is set to '1')
Type	R/W	PoR	00h		
D5h	MON_DAC				Sets the target bias current level (via a DAC) when the device is in closed loop configuration (OPENLOOP is set to '0')
Type	R/W	PoR	00h		
D8h	BIAS_DAC				Sets the bias current (via a DAC) when the device is in open loop configuration (OPENLOOP is set to '1') and the Bias / Temperature LUT is disabled (BIAS_TEMP_DISABLE is set to '1')
Type	R/W	PoR	00h		
D9h	OMA_DAC				Sets the threshold level for optical measurement amplitude based LOS detection
Type	R/W	PoR	00h		

DAh	ALARM_ENABLE			Controls the behaviour of the TX_FAULT pin and the generation of alarms based on temperature and bias current levels
Bit	Field name	Type	PoR	
7	-	R	0	reserved
6	-	R	0	reserved
5	FAULT_POWERD OWN_EN	R/W	0	If this bit is set to '1' a TX_FAULT condition will cause the transmitter modulation and bias currents to be shutdown
4	FAULT_LATCH_ EN	R/W	0	If this bit is set to a '0' the output pin TX_FAULT will remain asserted once a fault condition has been detected even if the fault condition goes away. The pin will remain asserted until either the device is reset or this bit is set to a '1'. If this bit is set to a '1' then the output pin TX_FAULT will be asserted if a fault condition is detected and will be deasserted once the condition is cleared.
3	TEMP_MAX_ ALARM_EN	R/W	0	Set this bit to a '1' to enable alarm generation if the measured temperature exceeds TEMP_MAX
2	TEMP_MIN_ ALARM_EN	R/W	0	Set this bit to a '1' to enable alarm generation if the measured temperature falls below TEMP_MIN
1	BIAS_MAX_ ALARM_EN	R/W	0	Set this bit to a '1' to enable alarm generation if the measured bias current exceeds BIAS_MAX
0	BIAS_MIN_ ALARM_EN	R/W	0	Set this bit to a '1' to enable alarm generation if the measured bias current falls below BIAS_MIN

DBh	TEMP_MAX			If TEMP_MAX_ALARM_EN is set then this register sets the threshold above which a maximum temperature error is raised based on the internal ADC reading.
Type	R/W	PoR	00h	Note, this register exists only in EEPROM and not in the internal registers of the device, therefore a write to this address when 'INTERNAL_ACCESS' is set high will be ignored and a read return zero.

DCh	TEMP_MIN			If TEMP_MIN_ALARM_EN is set then this register sets the threshold below which a minimum temperature error is raised based on the internal ADC reading.
Type	R/W	PoR	00h	Note, this register exists only in EEPROM and not in the internal registers of the device, therefore a write to this address when 'INTERNAL_ACCESS' is set high will be ignored and a read return zero.

DDh	BIAS_MAX			If BIAS_MAX_ALARM_EN is set then this register sets the threshold above which a maximum bias current error is raised based on the internal ADC reading.
Type	R/W	PoR	00h	Note, this register exists only in EEPROM and not in the internal registers of the device, therefore a write to this address when 'INTERNAL_ACCESS' is set high will be ignored and a read return zero.

DEh	BIAS_MIN			If BIAS_MIN_ALARM_EN is set then this register sets the threshold below which a minimum bias current error is raised based on the internal ADC reading. Note, this register exists only in EEPROM and not in the internal registers of the device, therefore a write to this address when 'INTERNAL_ACCESS' is set high will be ignored and a read return zero.
Type	R/W	PoR	00h	

The following registers exist only in the internal registers of the device. The corresponding addresses in EEPROM are unreachable. Therefore a TWI transaction to these addresses will target the internal device registers regardless of the setting of 'INTERNAL_ACCESS'.

E0h	TEST6			Internal use only, must be set to 00h
Type	R/W	PoR	00h	

E1h	TEMP_ADC_VALUE			Indicates the current temperature value measured by the internal ADC.
Type	R	PoR	00h	

E2h	BIAS_ADC_VALUE			Indicates the current bias current value measured by the internal ADC.
Type	R	PoR	00h	

E3h	TEST7			Internal use only, must be set to 00h
Type	R/W	PoR	00h	

E4h	TEST8			Internal use only, must be set to 00h
Type	R/W	PoR	00h	

E5h	TEST9			Internal use only, must be set to 00h
Type	R/W	PoR	00h	

E6h	TEST10			Internal use only, must be set to 00h
Type	R/W	PoR	00h	

E7h		INTERNAL		This register controls the internal state machines used to generate transmit modulation and bias currents
Bit	Field name	Type	PoR	
7	-	R	0	reserved
6	-	R	0	reserved
5	-	R	0	reserved
4	-	R	0	reserved
3	BIAS_SM_RESET	R/W	0	Set this bit to a '1' to put the bias current control logic into reset. Set to '0' for normal device operation
2	MOD_SM_RESET	R/W	0	Set this bit to a '1' to put the modulation current control logic into reset. Set to '0' for normal device operation
1	INTERNAL_ACCESS	R/W	0	Set this bit to a '1' to direct TWI accesses to addresses C0h – DFh to the internal registers of the device. If set to '0' such addresses map to the external EEPROM.
0	SM_STOP	R/W	0	Set this bit to a '1' to suspend the internal control logic and allow TWI accesses to the external EEPROM. If this bit is set to '0' and a TWI access is targeted at the EEPROM then a write will be ignored and a read will return zero.

E8h		TX_DISABLES		This register controls the transmit safety shutdown circuit. See section 4.4 for further details
Bit	Field name	Type	PoR	
7	-	R	0	reserved
6	-	R	0	reserved
5	-	R	0	reserved
4	-	R	0	reserved
3	-	R	0	reserved
2	SOFT_TX_FAULT	R/W	0	This bit allows a TX_FAULT to be declared under control of the TWI. Setting this bit to a '1' causes a TX_FAULT condition to be declared
1	SOFT_TX_DISABLE	R/W	0	This bit allows a TX_DISABLE to be declared under control of the TWI. Setting this bit to a '1' causes a TX_DISABLE condition to be declared
0	-	R/W	0	Internal use only. Must be set to '0'

E9h				EVENTS	This register contains latched versions of the bits in the STATUS register. If a condition becomes active the bit will report a '1'. If the condition goes inactive the bit will stay at '1' until a '1' is written to the bit via the TWI
Bit	Field name	Type	PoR		
7	TEMP_MAX_ERROR_E	E	0	Has value '1' if a maximum temperature error condition has occurred	
6	TEMP_MIN_ERROR_E	E	0	Has value '1' if a minimum temperature error condition has occurred	
5	BIAS_MAX_ERROR_E	E	0	Has value '1' if a maximum bias current error condition has occurred	
4	BIAS_MIN_ERROR_E	E	0	Has value '1' if a minimum bias current error condition has occurred	
3	TX_FAULT_E	E	0	Has value '1' if the output pin TX_FAULT has been asserted	
2	TX_SHUTDOWN_E	E	0	Has value '1' if a shutdown condition has been detected	
1	SM_TX_FAULT_E	E	0	Has value '1' if the internal control logic has reported a fault condition	
0	SM_TX_DISABLE_E	E	0	Has value '1' if the internal control has disabled the transmit circuitry	

EAh				STATUS	This register reports the status of a number of internally monitored conditions within the device. A bit will report a '1' if the condition is active and a '0' if the condition is inactive
Bit	Field name	Type	PoR		
7	TEMP_MAX_ERROR	R	0	Has value '1' if a maximum temperature error condition is currently being detected	
6	TEMP_MIN_ERROR	R	0	Has value '1' if a minimum temperature error condition is currently being detected	
5	BIAS_MAX_ERROR	R	0	Has value '1' if a maximum bias current error condition is currently being detected	
4	BIAS_MIN_ERROR	R	0	Has value '1' if a minimum bias current error condition is currently being detected	
3	TX_FAULT	R	0	Has value '1' if the output pin TX_FAULT is currently being asserted	
2	TX_SHUTDOWN	R	0	Has value '1' if a shutdown condition is currently being asserted	
1	SM_TX_FAULT	R	0	Has value '1' if the internal control logic is currently reporting a fault condition	
0	SM_TX_DISABLE	R	0	Has value '1' if the internal control logic is currently disabling the transmit circuitry	

EBh	HWARE_SENSE_EVENTS			This register contains latched versions of the bits in the HWARE_SENSE_STATUS register. If a condition becomes active the bit will report a '1'. If the condition goes inactive the bit will stay at '1' until a '1' is written to the bit via the TWI
Bit	Field name	Type	PoR	
7	-	R	0	reserved
6	-	R	0	reserved
5	-	R	0	reserved
4	TX_DISABLE_E	E	0	Has value '1' if the input pin TX_DISABLE changes from '0' to '1'
3	LOS_E	E	0	Has value '1' if the LOS detect circuit has detected a LOS condition
2	-	R	0	reserved
1	SUPPLY_OK_E	E	0	Has value '1' if the power supply monitoring circuit detects the supply voltage has gone from correct to incorrect
0	VREF_OK_E	E	0	Has value '1' if the voltage reference monitoring circuit detects the reference voltage has gone from correct to incorrect

ECh	HWARE_SENSE_STATUS			This register reports the status of various device input pins and detection circuits
Bit	Field name	Type	PoR	
7	-	R	0	reserved
6	-	R	0	reserved
5	LVMODE	R	0	Status of input pin 'lvmode' 0 = VCSEL mode 1 = laser mode
4	TX_DISABLE	E	0	Indicates the logical status of the input pin TX_DISABLE (after potential inversion according to TX_DISABLE_POLARITY)
3	LOS	E	0	Indicates the status of the LOS detect circuit. The polarity depends on MUX_POLARITY
2	-	R	0	reserved
1	SUPPLY_OK	E	0	Indicates the status of the power supply monitoring circuit. If set to '1' then the supply voltage is correct
0	VREF_OK	E	0	Indicates the status of the voltage reference monitoring circuit. If set to '1' then the reference voltage is correct

EDh		DEBUG_EVENTS		This register indicates whether certain events have occurred within the control logic of the device. If a condition occurs bit will report a '1' and will stay at '1' until a '1' is written to the bit via the TWI
Bit	Field name	Type	PoR	
7	-	R	0	reserved
6	-	R	0	reserved
5	-	R	0	reserved
4	INTEGRITY_FAIL_E	E	0	This bit is set to '1' by the device if the boot DMA from EEPROM fails its integrity check
3	DMA_FAIL_E	E	0	This bit is set to '1' by the device if a DMA from EEPROM does not complete successfully
2	BOOT_FAIL_E	E	0	This bit is set to '1' by the device if the boot DMA from EEPROM does not complete successfully
1	BOOT_COMPLETE_E	E	0	This bit is set to '1' by the device if the boot DMA from EEPROM completes successfully
0	ITERATION_E	E	0	This bit is set to '1' by the device once per iteration of the modulation state machine logic (approx every 10ms)

EFh		BIAS_DAC_OBSERVE		This register indicates the current value of the transmit bias current setting DAC
Type	R	PoR	00h	
Type	R	PoR	00h	

F0h		MOD_DAC_OBSERVE		This register indicates the current value of the transmit modulation current setting DAC
Type	R/W	PoR	00h	
Type	R/W	PoR	00h	

FFh		TEST11		Internal use only
Type	R	PoR	-	
Type	R	PoR	-	

7. Simplified Interface Models

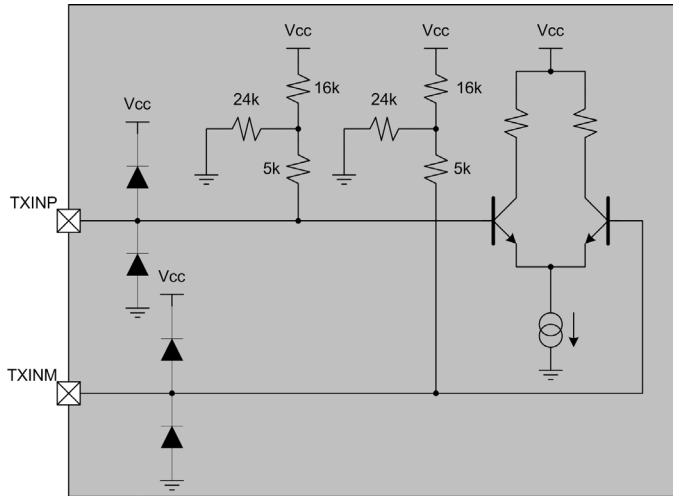

Figure 27 - Transmit input structure

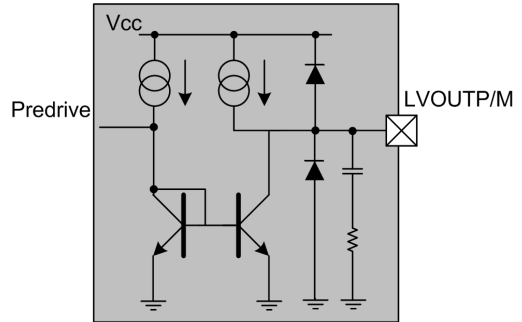

Figure 28 - Transmit output structure

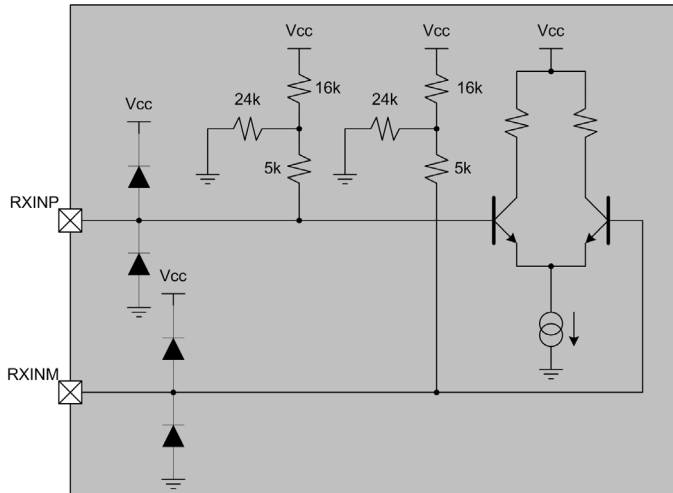

Figure 29- Receive input structure

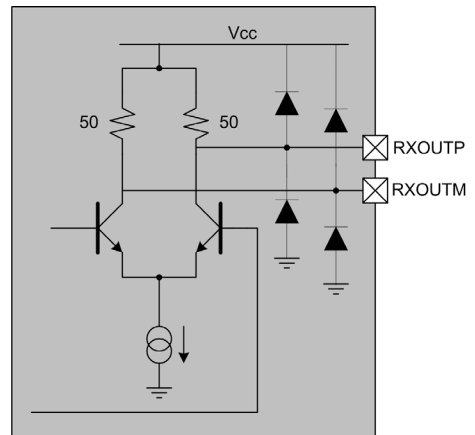

Figure 30- Receive output structure

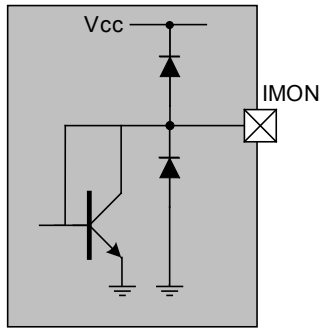

Figure 31 - MPD input structure

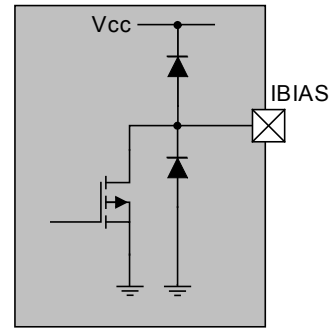

Figure 32 - VCSEL/Laser bias output structure

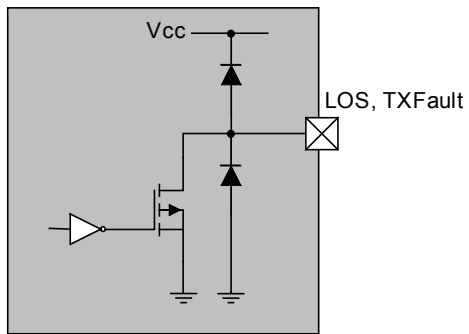

Figure 33 - LOS/TX_FAULT output

8. Applications Information

8.1. Power Supply Connections

The PHY1040-01 has been designed as a low power device. In order to achieve low operating power consumption the transmitter and receiver circuitry in the PHY1040-01 share some common internal bias circuitry. This requires that the PHY1040-01 transmitter and receiver be powered up together for correct operation.

8.1.1. Power Supply Filtering

Although the Tx VDDs and Rx VDDs should be powered together and therefore, ultimately be connected at a common node, it is beneficial to separately filter the power supplies for the Tx VDD and Rx VDD supplies. Separately filtering the transmitter and receiver supplies off chip will reduce power supply noise and cross talk between the transmitter and receiver – it is generally good practice to separately filter and decouple the individual supplies on any multifunction IC.

In addition to supplying separately filtered supplies to the Tx VDDs and Rx VDDs of the PHY1040-01, it is recommended that any other ICs and digital circuitry connected to the PHY1040-01 in an application environment (e.g. SFF module) be suitably filtered and decoupled. An example of this would be to supply a filtered digital supply for an external MCU.

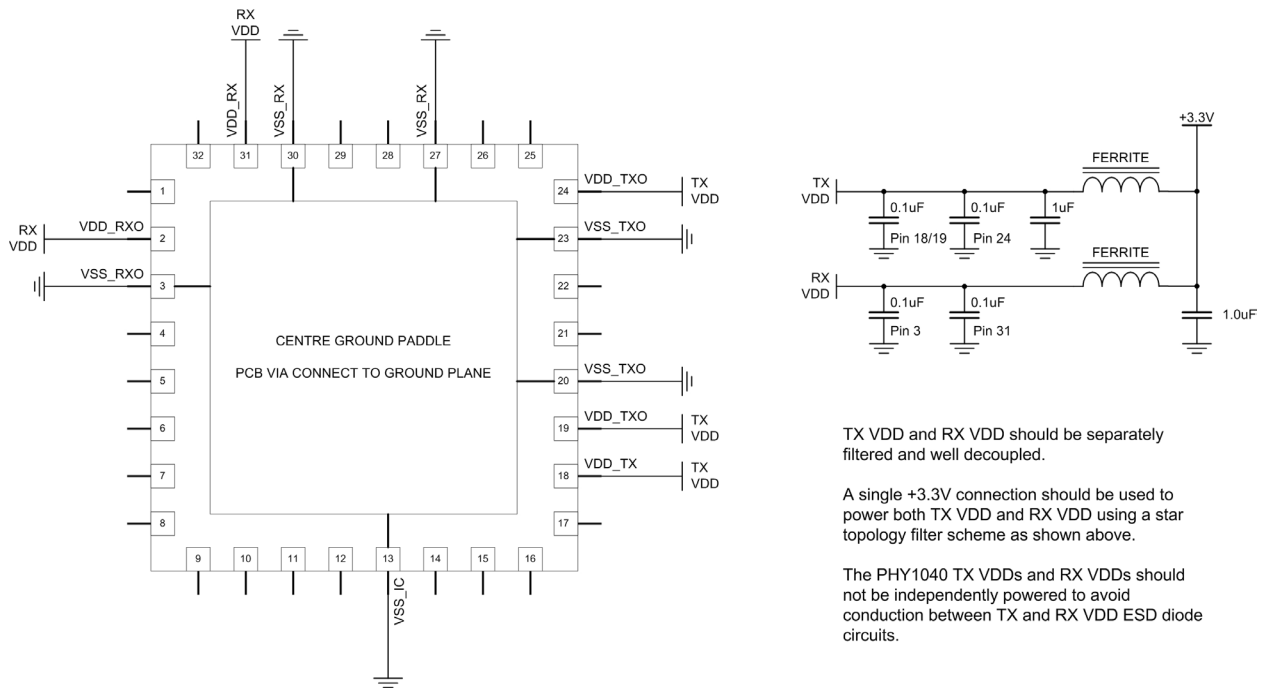

Figure 34 – Recommended power supply connections and filtering.

8.3. VCSEL/Laser Connection – AC-Coupled

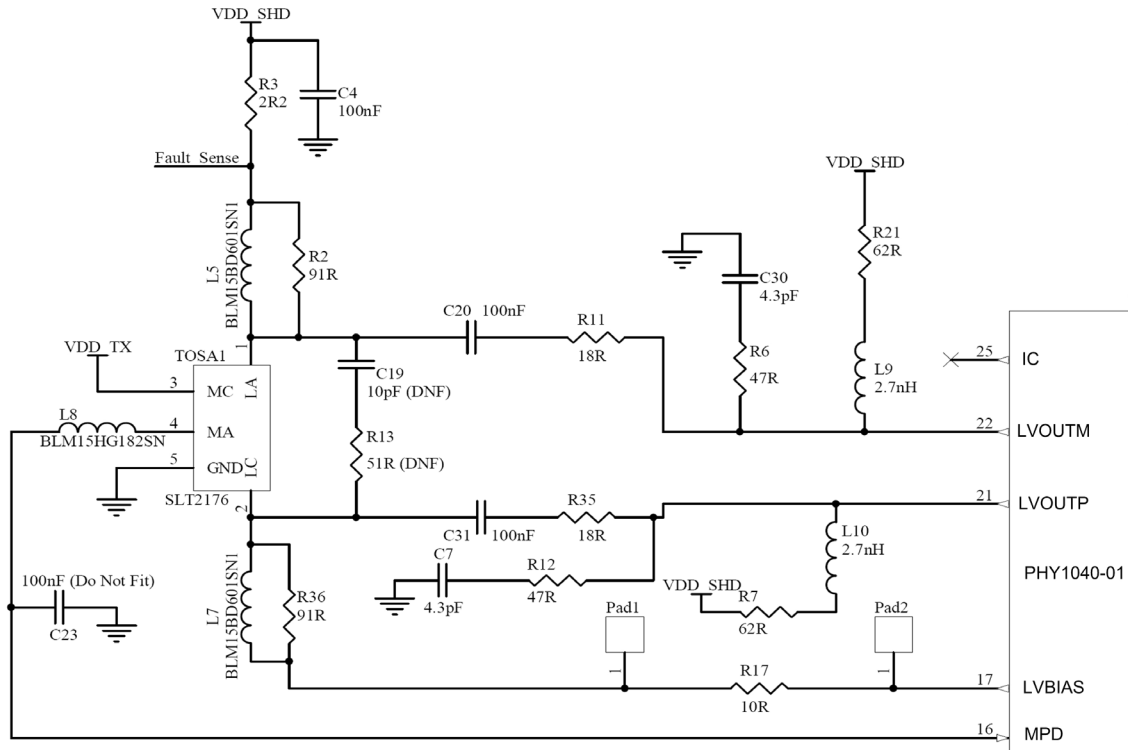

Figure 36 – AC-Coupled Application Diagram

8.4. TX_Fault Circuit – Standalone Mode

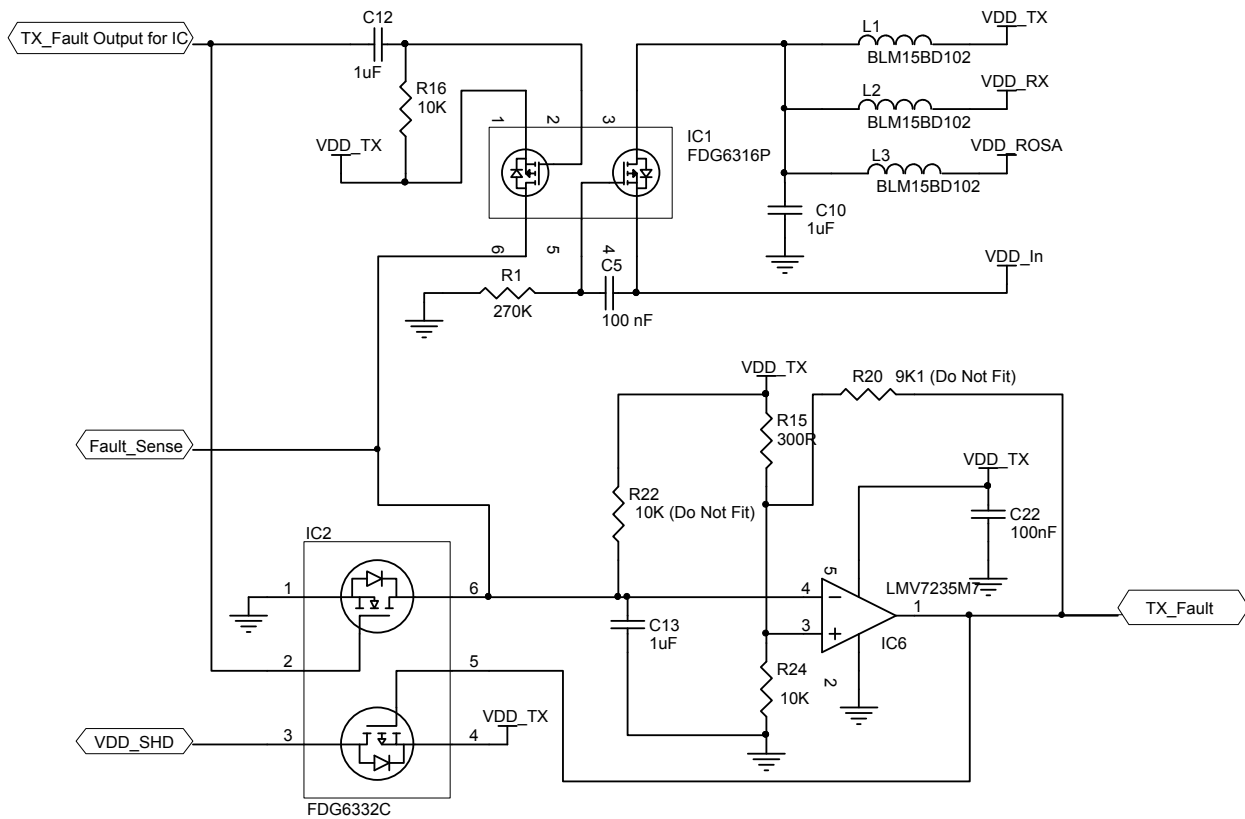

Figure 37 – TX_Fault Circuit

A VCSEL/Laser safety timing circuit is provided for PHY1040-01 used in standalone mode. The circuit will detect and shutdown the VCSEL/Laser within SFP MSA specified timing in case of hardware faults such as short circuits to the VCSEL/Laser or TX_FAULT software faults from PHY1040-01. When used with an external microcontroller the circuit can be modified to use the internal comparator of the microcontroller.

The safety logic detects voltage variation at Fault_Sense and compares it with a preset threshold of $0.94V_{cc}$. During normal operation, voltage at Fault_Sense is higher than $0.94V_{cc}$ and the comparator output is low. When DC current flow through Fault_Sense is higher than 90mA, the voltage at Fault_Sense will drop to less than $0.94V_{DD}$ and the comparator output will be asserted to high to shut down IC1 and turn off the VCSEL/Laser supply voltage. The current threshold can be adjusted by varying R15 and R24. The comparator output will remain high and will not be cleared by toggling the TX_Disable input.

When the fault is generated by PHY1040-01, the TX_Fault output will be asserted to high which will turn on IC2 and assert comparator output to high to switch off LD using IC1. If the fault is transient, the transmission can be restarted by toggling the TX_Disable input.

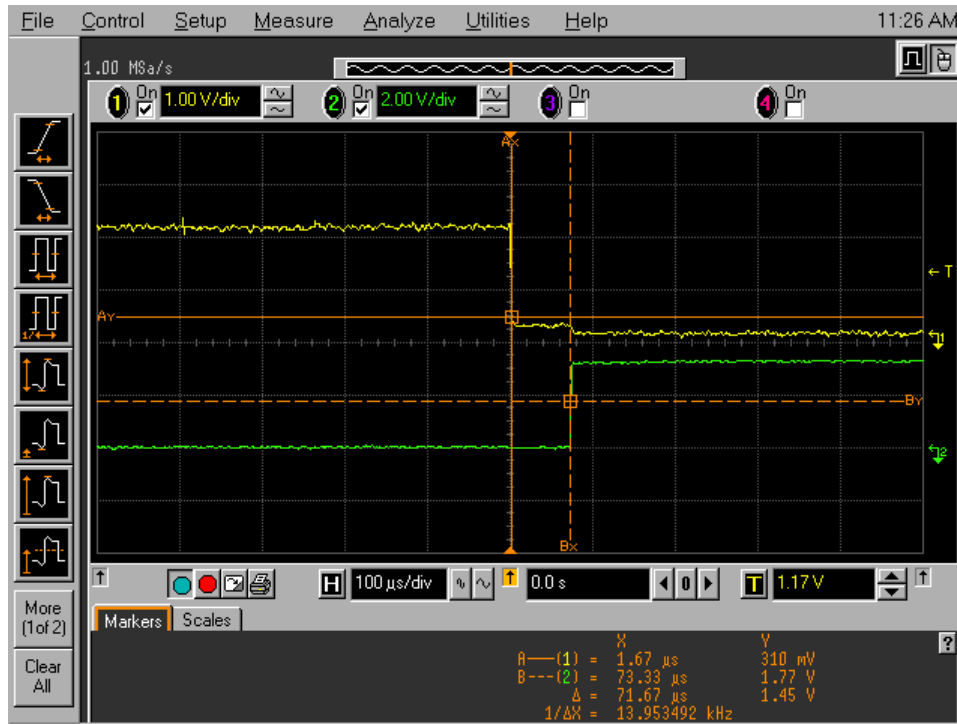

Figure 38 - TX_Fault Timing Result

The Fault shown in Figure 38 is generated by connecting the VCSEL/Laser cathode to ground. The yellow trace is the voltage at the VCSEL/Laser Cathode.

9. Packaging

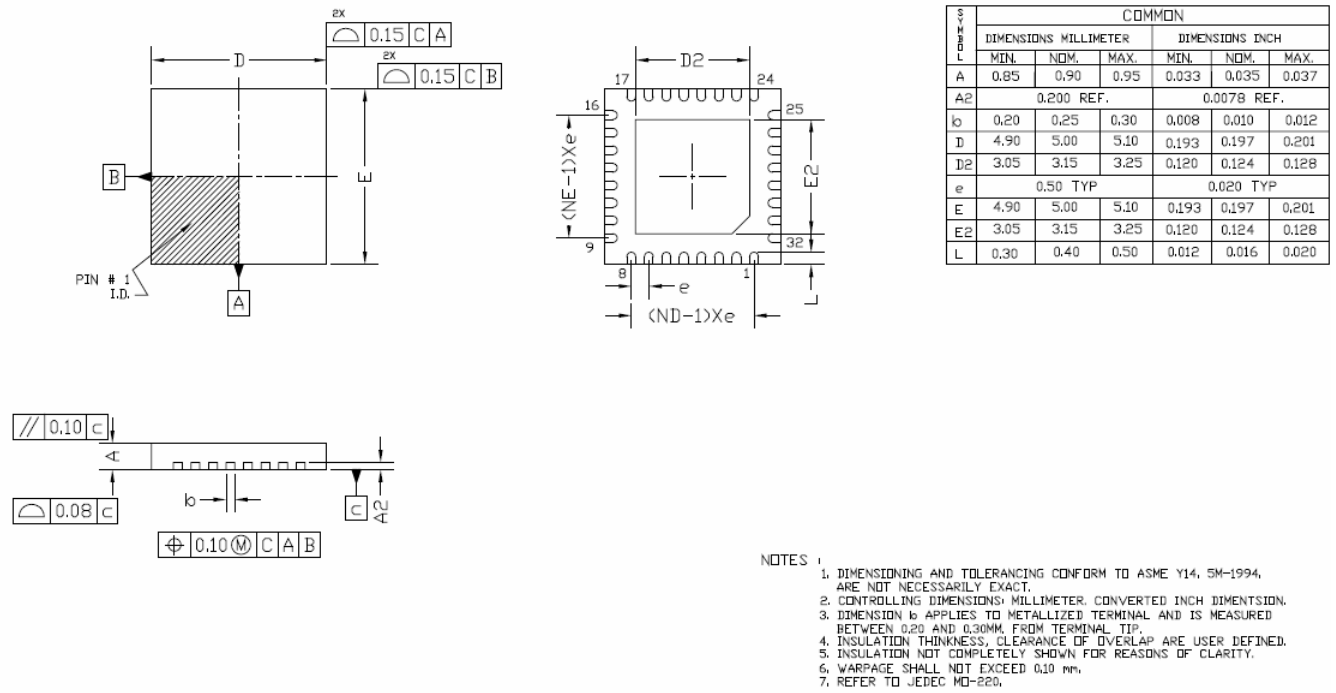

Figure 39 – 32pin QFN Package Dimensions

	Symbol	Typical	Unit
Thermal Resistance – Junction to Ambient	θ_{Ja}	39	°C/W
Thermal Resistance – Junction to Case	θ_{Jc}	31	°C/W

Note: Refer to EIA/JEDEC standard JESD51 for test method and conditions

Table 6 - 32pin QFN Package Thermal Data

10. Contact Information

For technical support, contact Maxim at www.maxim-ic.com/support.

Disclaimer

This datasheet contains preliminary information and is subject to change.

The PHY1040-01 contains circuitry to aid the implementation of eye safety functions in equipment using VCSEL/Laser devices. Phyworks Ltd accepts no liability for failure of this function in this product nor for injury to persons as a result of use of this product. Testing of the functionality of eye safety circuits in equipment using this product is the responsibility of the manufacturer of the equipment.

This document does not transfer or license any intellectual property rights to the user.

Phyworks Ltd assumes no liability or warranty for infringement of patent, copyright or other intellectual property rights through the use of this product.

Phyworks Ltd assumes no liability for fitness for particular use or claims arising from sale or use of its products.

Phyworks Ltd products are not intended for use in life critical or sustaining applications.

Maxim cannot assume responsibility for use of any circuitry other than circuitry entirely embodied in a Maxim product. No circuit patent licenses are implied. Maxim reserves the right to change the circuitry and specifications without notice at any time.

Maxim Integrated Products, Inc. 160 Rio Robles, San Jose, CA 95134 USA 1-408-601-1000