

## SMD ■ Low Power LED 61-238/XK2C-SXXXXXXXXXX/ET



### Features

- P-LCC-6 package
- Top view LED
- Wide viewing angle:120°
- High Luminous intensity
- High Efficacy
- Pb-free
- RoHS-compliant
- ANSI Binning
- 

### Description

The Everlight 61-238 package has high efficacy, high CRI, low power consumption, wide viewing angle and a compact form factor. These features make this package an ideal LED for all lighting applications.

### Applications

- General lighting
- Decorative and Entertainment Lighting
- Indicators
- Illumination
- Switch lights

**Product Number Explanation**

**61-238 / X K 2 C - S XX XX XX XX XX / ET**

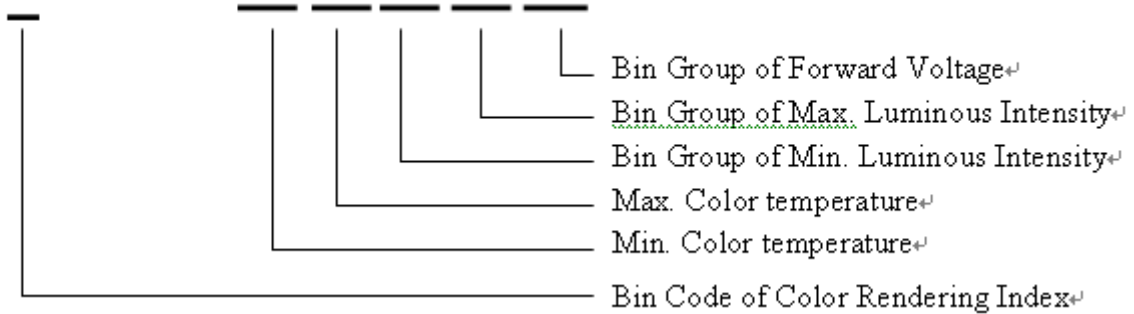

Notes

Table of Color Rendering Index

Symbol	Description
M	CRI(min) : 60
N	CRI(min) : 65
L	CRI(min) : 70
Q	CRI(min) : 75
K	CRI(min) : 80
H	CRI(min) : 90

Notes:

1. Tolerance of Color Rendering Index: ±2

Example:

61-238/KK2C-S30306F4GB2/ET

CRI	Min=80
CCT	3000K
IV	5400mcd~6400mcd
VF	2.9V~3.6V

**Mass Production list**

Product	CRI min.	CCT(K)	IV(mcd) Min	IV(mcd) Max	Φ(lm) Typ.
61-238/KK2C-S30306F4GB2/ET	80	3000K	5400	6400	17.0
61-238/KK2C-S40408F6GB2/ET	80	4000K	5600	6600	18.0

## Device Selection Guide

Chip Materials	Emitted Color	Resin Color
InGaN	Neutral White Warm White	Water Clear

## Absolute Maximum Ratings (Ta=25°C) \*1

Parameter	Symbol	Rating	Unit
Reverse Voltage*1	V <sub>R</sub>	5	V
Forward Current*1	I <sub>F</sub>	30	mA
Peak Forward Current(Duty 1/10 @ 1KHZ)*1	I <sub>FP</sub>	100	mA
Power Dissipation*1	P <sub>d</sub>	110	mW
Electrostatic Discharge(HBM) *1	ESD	1000	°C
Operating Temperature	T <sub>opr</sub>	-40 ~ +85	°C
Storage Temperature	T <sub>stg</sub>	-40 ~ +90	°C
Soldering Temperature	T <sub>sol</sub>	Reflow Soldering : 260 °C for 10 sec. Hand Soldering : 350 °C for 3 sec.	

\* 1. The value are based on 1 die performance

## Electro-Optical Characteristics (Ta=25°C)

Parameter	Symbol	Min.	Typ.	Max.	Unit	Condition
Viewing Angle *1	2θ <sub>1/2</sub>	-----	120	-----	deg	I <sub>F</sub> =20mA *2
Reverse Current	I <sub>R</sub>	-----	-----	50	μA	V <sub>R</sub> =5V

\*1 When three LED dies are operated simultaneously.

\*2 For each die.

**Bin Range of Luminous Intensity<sup>\*1</sup>**

Bin Code	Min.	Max.	Unit	Condition
4D	3200	3400		
6D	3400	3600		
8D	3600	3800		
AE	3800	4000		
2E	4000	4200		
4E	4200	4400		
6E	4400	4600		
8E	4600	4800		
AF	4800	5000	mcd	I <sub>F</sub> =20mA <sup>*2</sup>
2F	5000	5200		
4F	5200	5400		
6F	5400	5600		
8F	5600	5800		
AG	5800	6000		
2G	6000	6200		
4G	6200	6400		
6G	6400	6600		

Notes:

- \*1 When three LED dies are operated simultaneously.
- \*2 For each die.
- Tolerance of Luminous Intensity ±11%

**Bin Range of Forward Voltage<sup>\*1</sup>**

Group	Bin Code	Min.	Max.	Unit	Condition	
G		34	2.7	2.8	v	$I_F=20mA$ <sup>*2</sup>
		35	2.8	2.9		
	B2	36	2.9	3.0		
		37	3.0	3.1		
		38	3.1	3.2		
		39	3.2	3.3		
		40	3.3	3.4		
		41	3.4	3.5		
		42	3.5	3.6		
		43	3.6	3.7		

Notes:

- \*1 When three LED dies are operated simultaneously.
- \*2 For each die.
- Tolerance of Forward Voltage  $\pm 0.05V$
- Forward Voltage rank is the average forward voltage of three dies

**Bin Range of Chromaticity Coordinates**

CCT	Bin Code	CIE_x	CIE_y	Bin Code	CIE_x	CIE_y
4000K	40K-1	0.4006	0.4044	40K-3	0.3828	0.3803
		0.3871	0.3959		0.3703	0.3726
		0.3828	0.3803		0.3670	0.3578
		0.3952	0.3880		0.3784	0.3647
	40K-2	0.3871	0.3959	40K-4	0.3952	0.3880
		0.3736	0.3874		0.3828	0.3803
		0.3703	0.3726		0.3784	0.3647
		0.3828	0.3803		0.3898	0.3716
3000K	30K-1	0.4562	0.4260	30K-3	0.4345	0.4033
		0.4431	0.4213		0.4223	0.3990
		0.4345	0.4033		0.4147	0.3814
		0.4468	0.4077		0.4260	0.3854
	30K-2	0.4431	0.4213	30K-4	0.4468	0.4077
		0.4299	0.4165		0.4345	0.4033
		0.4223	0.3990		0.4260	0.3854
		0.4345	0.4033		0.4373	0.3893

Note:  
 Tolerance of Chromaticity Coordinates: ±0.01

### The C.I.E. 1931 Chromaticity Diagram

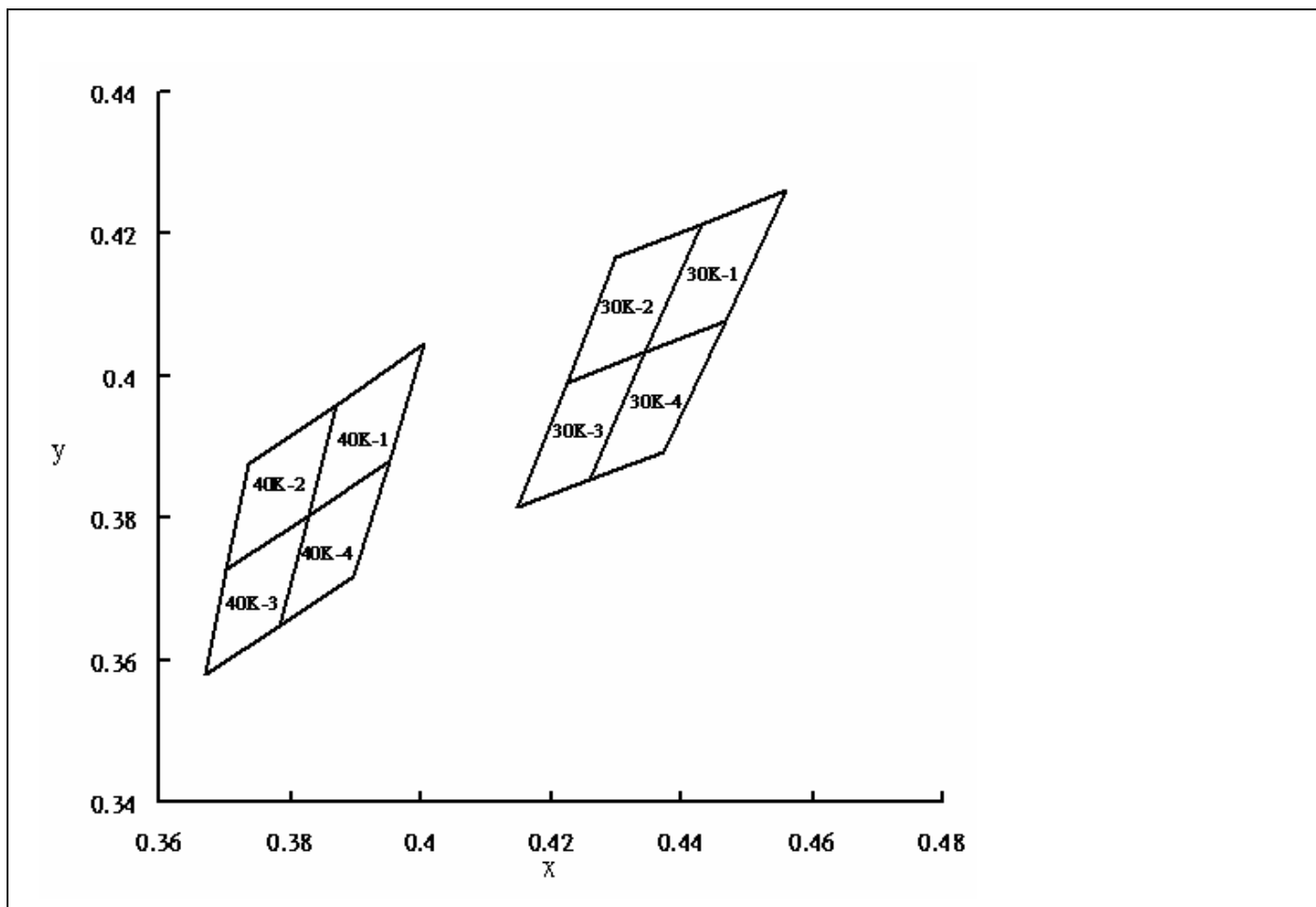



**Typical Electro-Optical Characteristics Curves**

Spectrum Distribution

Ta=25°

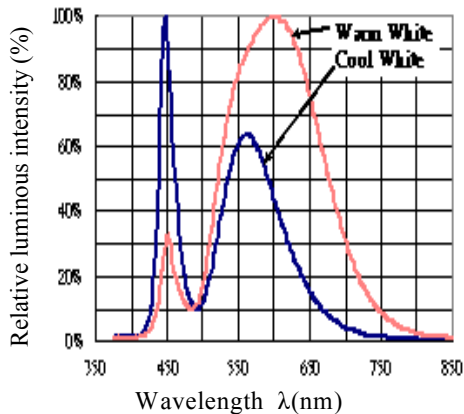

Forward Current vs. Forward Voltage

Ta=25°

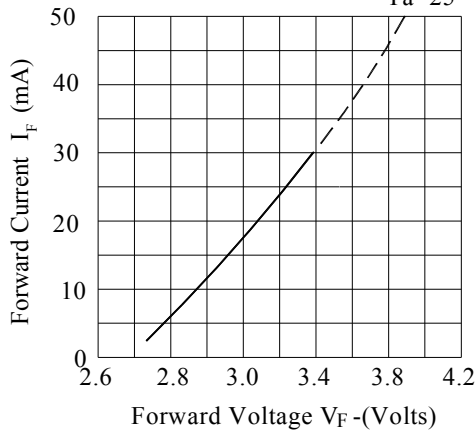

Relative Luminous Intensity vs. Ambient Temperature

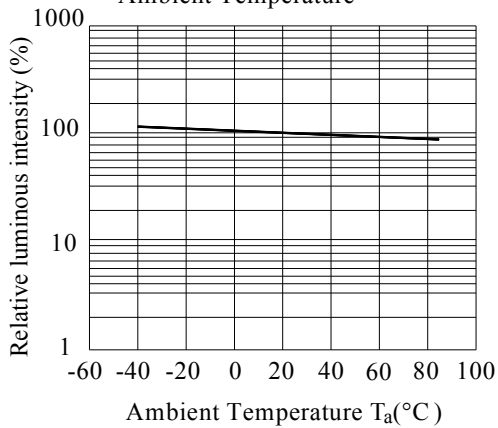

Relative Luminous Intensity vs. Forward Current

Ta=25°

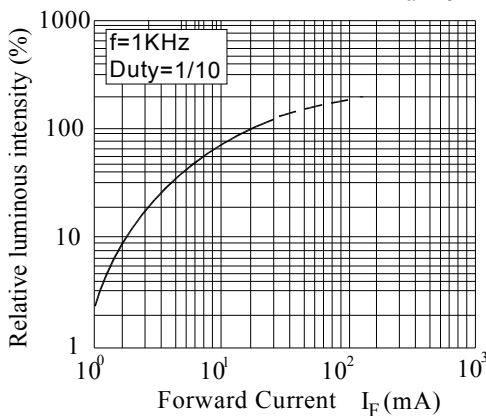

Forward Current Derating Curve

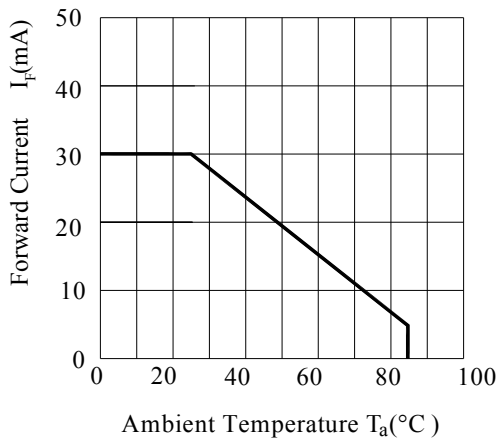

Radiation Diagram

0° 10° 20° Ta=25°

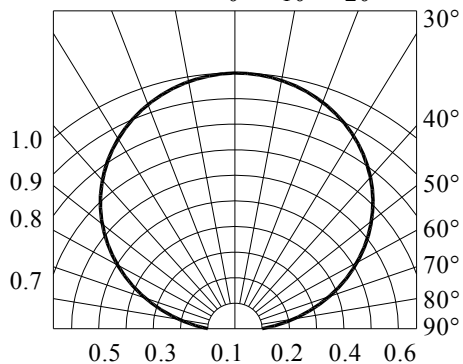

**Package Dimension**

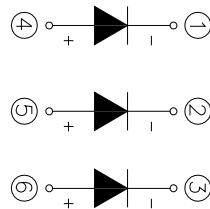
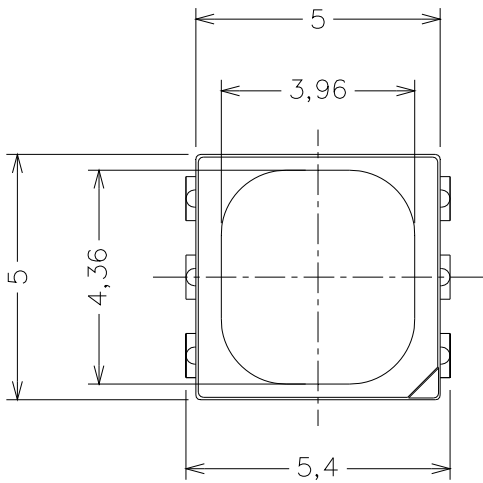

Polarity

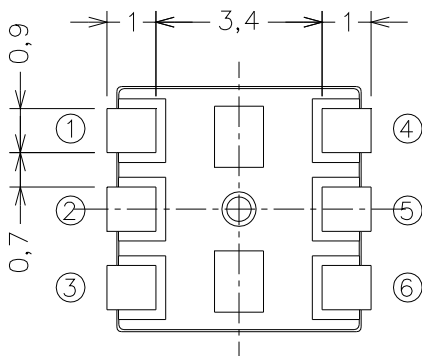
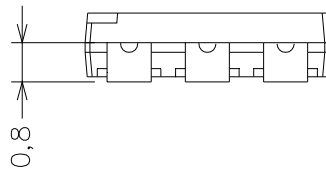
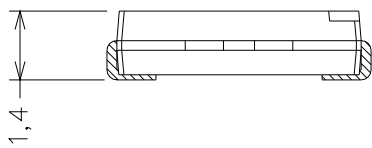

Bot. view

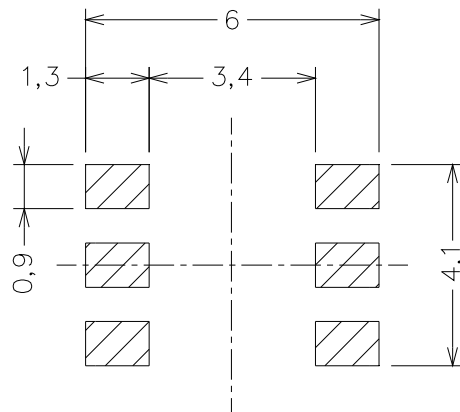

Soldering patterns

Note:  
 Tolerance unless mentioned is  $\pm 0.1\text{mm}$ ; Unit = mm

**Moisture Resistant Packing Materials**

**Label Explanation**



- CPN: Customer's Product Number
- P/N: Product Number
- QTY: Packing Quantity
- CAT: Luminous Intensity Rank
- HUE: Dom. Wavelength Rank
- REF: Forward Voltage Rank
- LOT No: Lot Number

**Reel Dimensions**

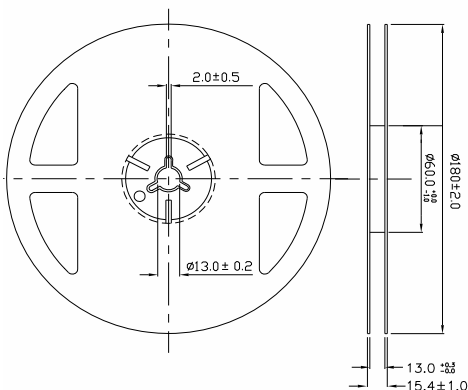

**Carrier Tape Dimensions: Loaded Quantity 800 pcs Per Reel**

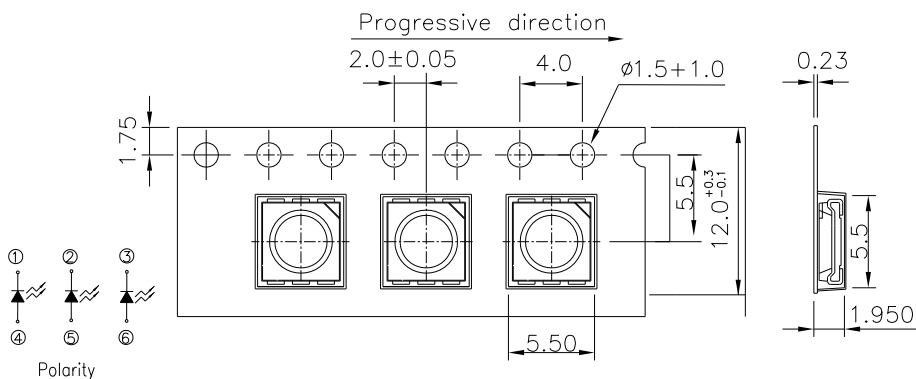

Note:  
 Tolerances unless mentioned ±0.1mm. Unit = mm

**Moisture Resistant Packing Process**

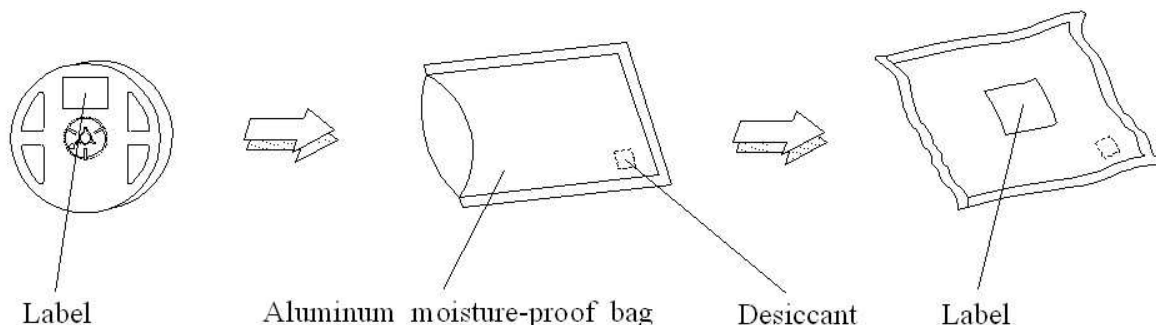

Note:  
 Tolerances unless mentioned ±0.1mm. Unit = mm

**Reliability Test Items and Conditions**

The reliability of products shall be satisfied with items listed below.

Confidence level : 90%

LTPD : 10%

No.	Items	Test Condition	Test Hours/Cycles	Sample Size	Ac/Re
1	Reflow Soldering	Temp. : 260°C ±5°C Min. 10sec.	6 Min.	22 PCS.	0/1
2	Temperature Cycle	H : +100°C 15min ∫ 5 min L : -40°C 15min	300 Cycles	22 PCS.	0/1
3	Thermal Shock	H : +100°C 5min ∫ 10 sec L : -10°C 5min	300 Cycles	22 PCS.	0/1
4	High Temperature Storage	Temp. : 100°C	1000 Hrs.	22 PCS.	0/1
5	Low Temperature Storage	Temp. : -40°C	1000 Hrs.	22 PCS.	0/1
6	DC Operating Life	I <sub>F</sub> <sup>*2</sup> = 20 mA	1000 Hrs.	22 PCS.	0/1
7	High Temperature / High Humidity	85°C / 85%RH	1000 Hrs.	22 PCS.	0/1

## Precautions for Use

### 1. Over-current-proof

Customer must apply resistors for protection; otherwise slight voltage shift will cause big current change (Burn out will happen).

### 2. Storage

2.1 Do not open moisture proof bag before the products are ready to use.

2.2 Before opening the package: The LEDs should be kept at 30°C or less and 90%RH or less.

2.3 After opening the package: The LED's floor life are 168 hours under 30°C or less and 60% RH or less. If unused LEDs remain, it should be stored in moisture proof packages.

2.4 If the moisture absorbent material (silica gel) has faded away or the LEDs have exceeded the storage time, baking treatment should be performed using the following conditions.

Baking treatment: 60±5°C for 24 hours.

### 3. Soldering Condition

#### 3.1 Pb-free solder temperature profile

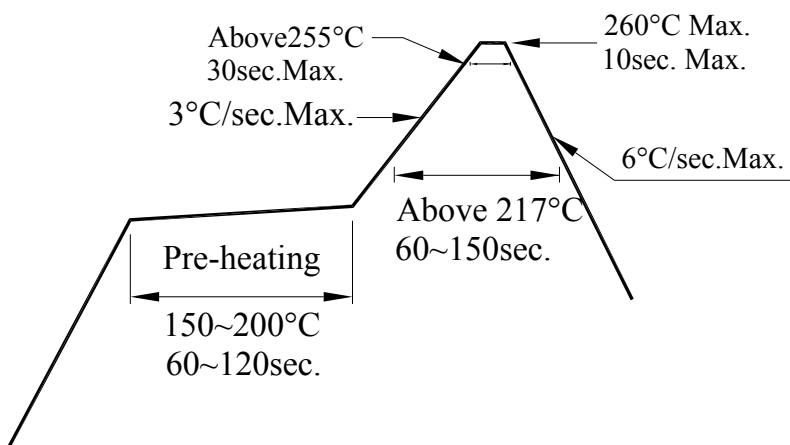

3.2 Reflow soldering should not be done more than two times.

3.3 When soldering, do not put stress on the LEDs during heating.

3.4 After soldering, do not warp the circuit board.

#### 4. Soldering Iron

Each terminal is to go to the tip of soldering iron temperature less than 350°C for 3 seconds within once in less than the soldering iron capacity 25W. Leave two seconds and more intervals, and do soldering of each terminal. Be careful because the damage of the product is often started at the time of the hand solder.

#### 5. Repairing

Repair should not be done after the LEDs have been soldered. When repairing is unavoidable, a double-head soldering iron should be used (as below figure). It should be confirmed beforehand whether the characteristics of the LEDs will or will not be damaged by repairing.

