



## Technical Data Sheet

# Luminosity white Color LED

### 59-146UTD/TR8

#### Features

- Super luminosity white LED.
- Built in 4 LED chips.
- Wide viewing angle.
- Soldering methods: Reflow soldering.
- High performance.
- Package in 12mm tape on 7" diameter reel.
- Pb-free.
- The product itself will remain within RoHS compliant version.

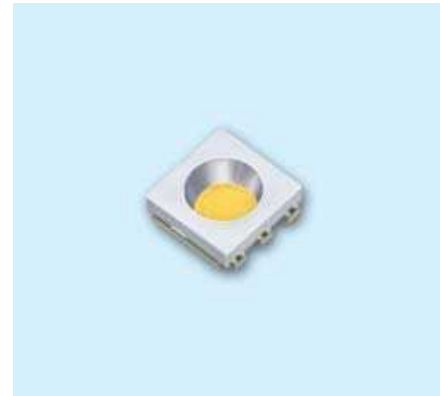

#### Descriptions

- The 59-146 SMD LED is much smaller than lead frame type components, thus enable smaller board size, higher packing density, reduced storage space and finally smaller equipment to be obtained.
- Besides, lightweight makes them ideal for miniature applications. etc.

#### Applications

- Amusement equipment.
- Information boards.
- Flashlight for digital camera of cellular phone.
- Lighting for small size device.

#### Device Selection Guide

Chip		Resin Color
Material	Emitted Color	
InGaN	White	Yellow diffused

**Package Outline Dimensions**

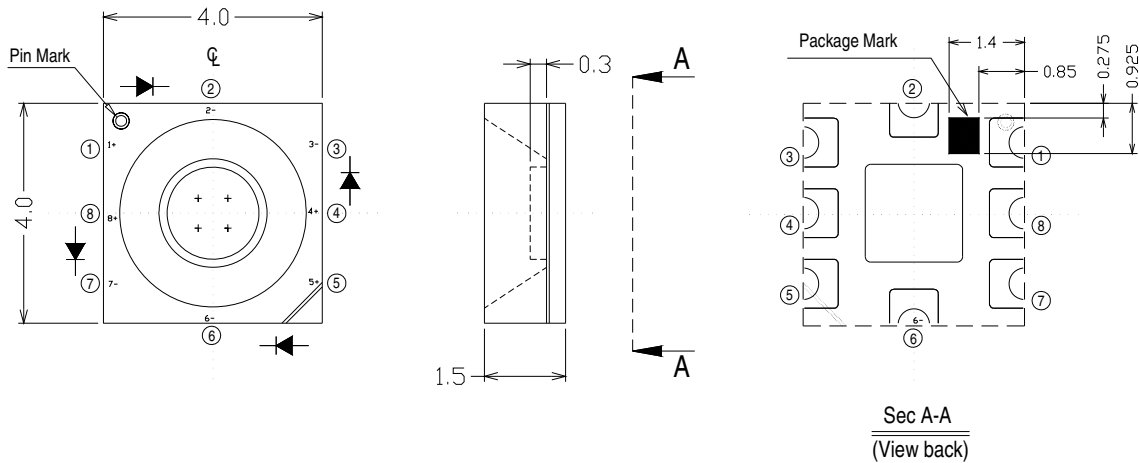

Solder pattern

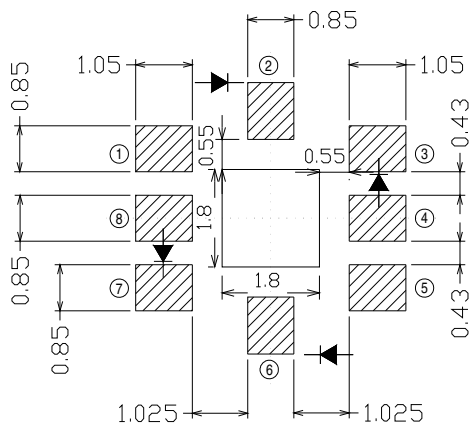

Polarity

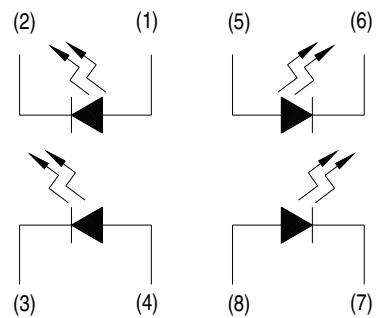

**Note:** The tolerances unless mentioned is  $\pm 0.1$ mm ,Unit = mm

**Absolute Maximum Ratings (Ta=25°C)**

Parameter	Symbol	Rating	Unit
Reverse Voltage	V <sub>R</sub>	5	V
Forward Current	I <sub>F</sub>	30	mA
Peak Forward Current (Duty 1/10 @ 400ms)	I <sub>FP</sub>	100	mA
Power Dissipation	P <sub>d</sub>	110	mW
Electrostatic Discharge(HBM)	ESD	1000	V
Electrostatic Discharge (CDM)	ESD	500	V
Operating Temperature	T <sub>opr</sub>	-40 ~ +85	°C
Storage Temperature	T <sub>stg</sub>	-40 ~ +90	°C
Soldering Temperature	T <sub>sol</sub>	Reflow Soldering : 260 °C for 10 sec. Hand Soldering : 350 °C for 3 sec.	

\* The value are base d on the 1-die performance.

**Electro-Optical Characteristics (Ta=25°C)**

Parameter	Symbol	Min.	Typ.	Max.	Unit	Condition
Luminous Intensity*1	I <sub>v</sub>	5.0	8.5	15.0	cd	I <sub>F</sub> =20mA*2
		10.0	25.0	45.0		I <sub>FP</sub> =100mA*2 (Duty 1/10 @ 400ms)
Viewing Angle*1	2θ <sub>1/2</sub>	-----	50	-----	deg	I <sub>F</sub> =20mA*2
Forward Voltage*2	V <sub>F</sub>	2.0	2.4	2.8	V	I <sub>F</sub> =0.1mA*2
		2.8	3.2	3.7		I <sub>F</sub> =20mA*2
Forward Voltage*2 -25°C < T < 30°C		3.6	4.3	5.2		I <sub>FP</sub> =100mA*2 (Duty 1/10 @ 400ms)
Reverse Current*2	I <sub>R</sub>	-----	-----	50	μA	V <sub>R</sub> =5V*2

\*1 When 4 LED dies are operated simultaneously.

\*2 For each die.

Note: The products are sensitive to static electricity and care must be fully taken when handling products.

**Color Ranks**

	Rank B3			
x	0.327	0.323	0.344	0.347
y	0.335	0.345	0.370	0.355

	Rank B4			
x	0.347	0.344	0.370	0.370
y	0.355	0.370	0.400	0.379

	Rank B5			
x	0.336	0.327	0.347	0.351
y	0.316	0.335	0.355	0.334

	Rank B6			
x	0.351	0.347	0.370	0.370
y	0.334	0.355	0.379	0.358

	Rank C0			
x	0.370	0.370	0.401	0.396
y	0.358	0.400	0.425	0.391

\*The C.I.E. 1931 chromaticity diagram ( Tolerance  $\pm 0.01$ ).

**CIE Chromaticity Diagram**

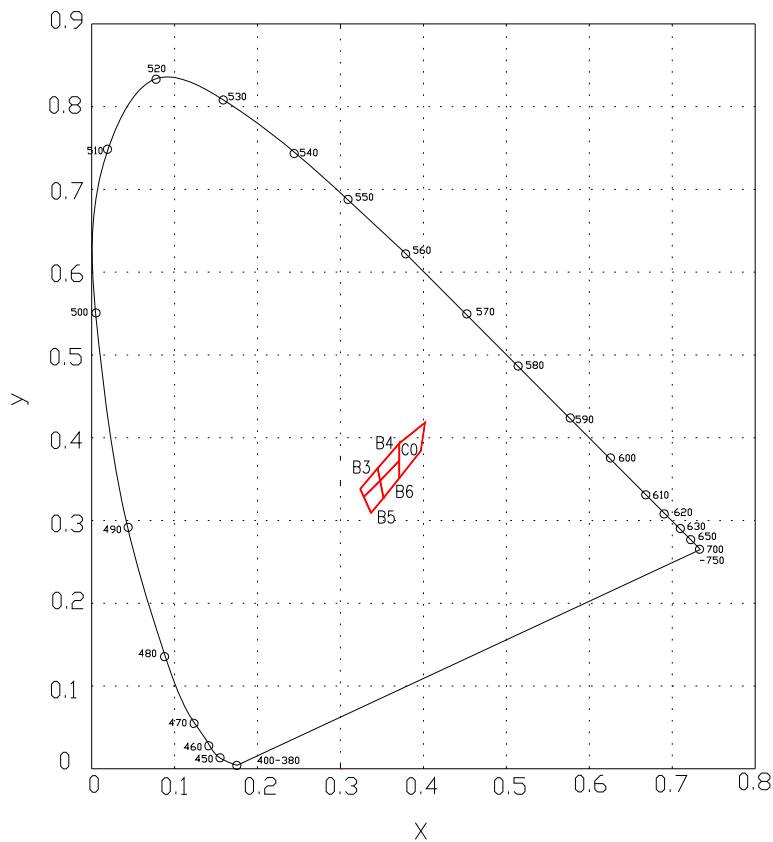

**Typical Electro-Optical Characteristics Curves**

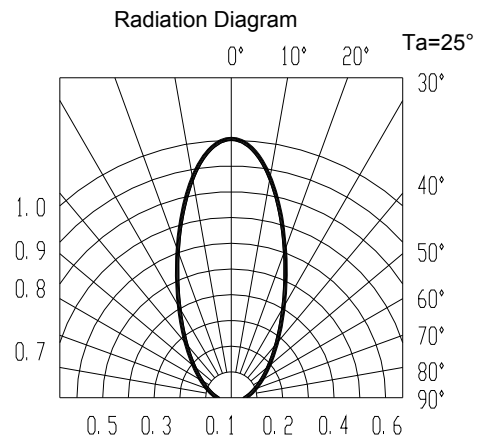
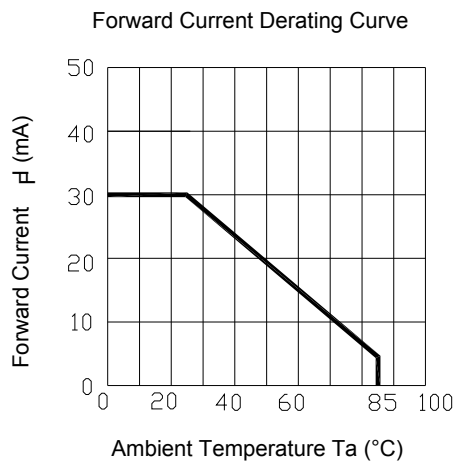
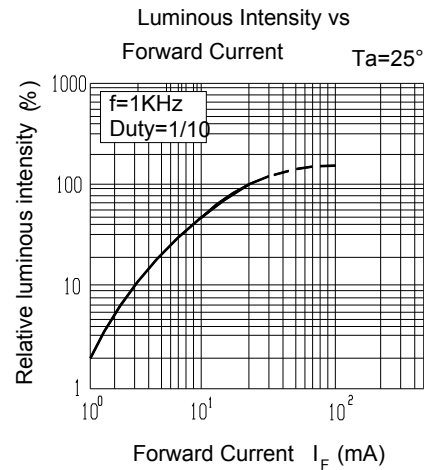
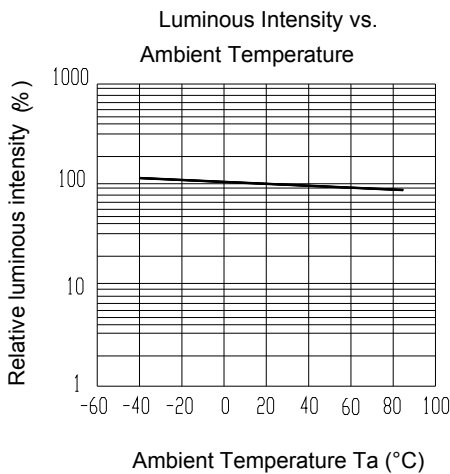
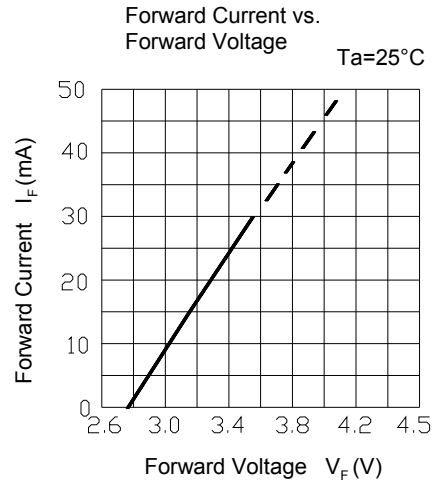
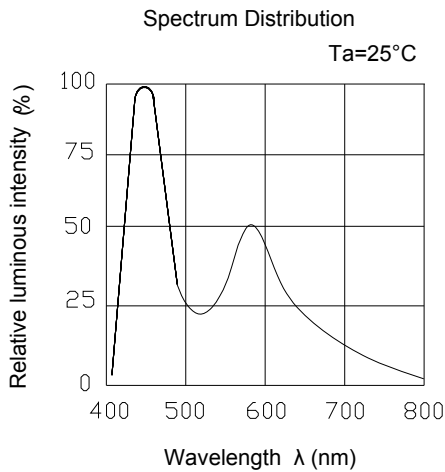

**Label explanation**

**CAT: Luminous Intensity Rank    HUE: Chromaticity Coordinates    REF: Forward Voltage Rank**

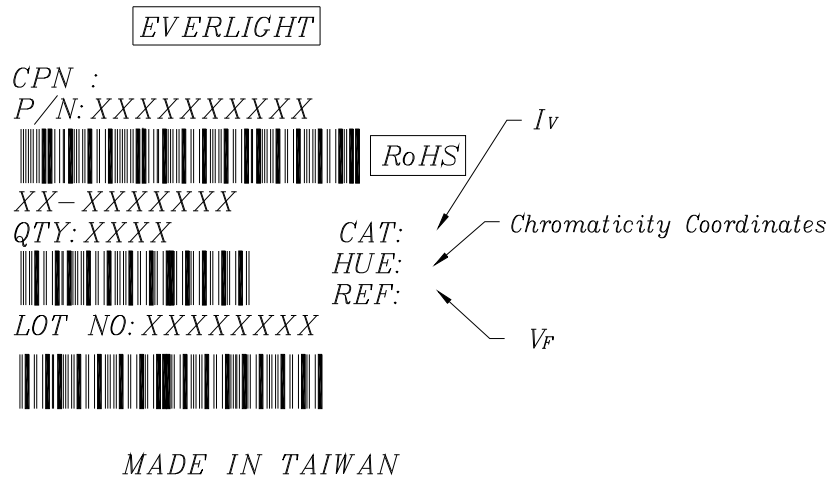

**Reel Dimensions**

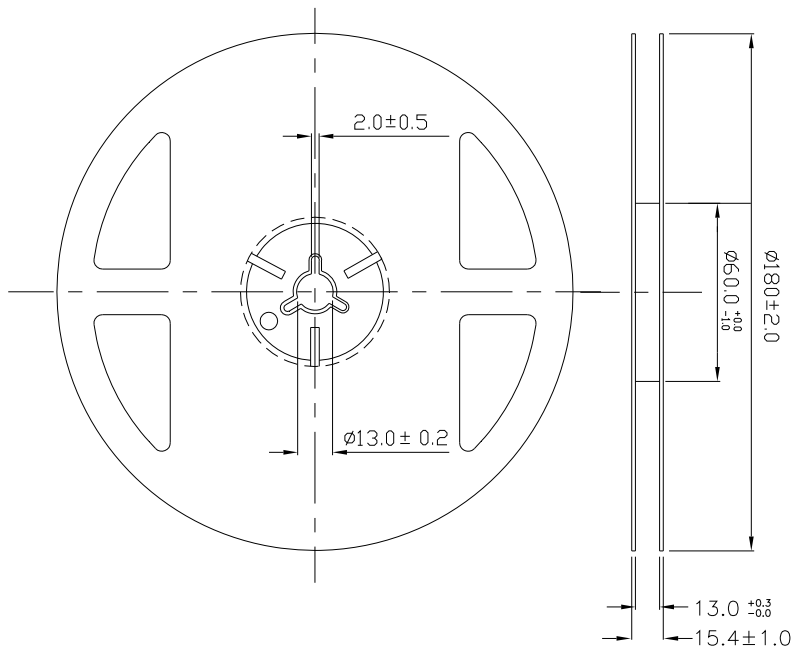

**Note:** The tolerance unless mentioned is ±0.1mm ,unit is mm

**Carrier Tape Dimensions: Taping Quantity: 800pcs**

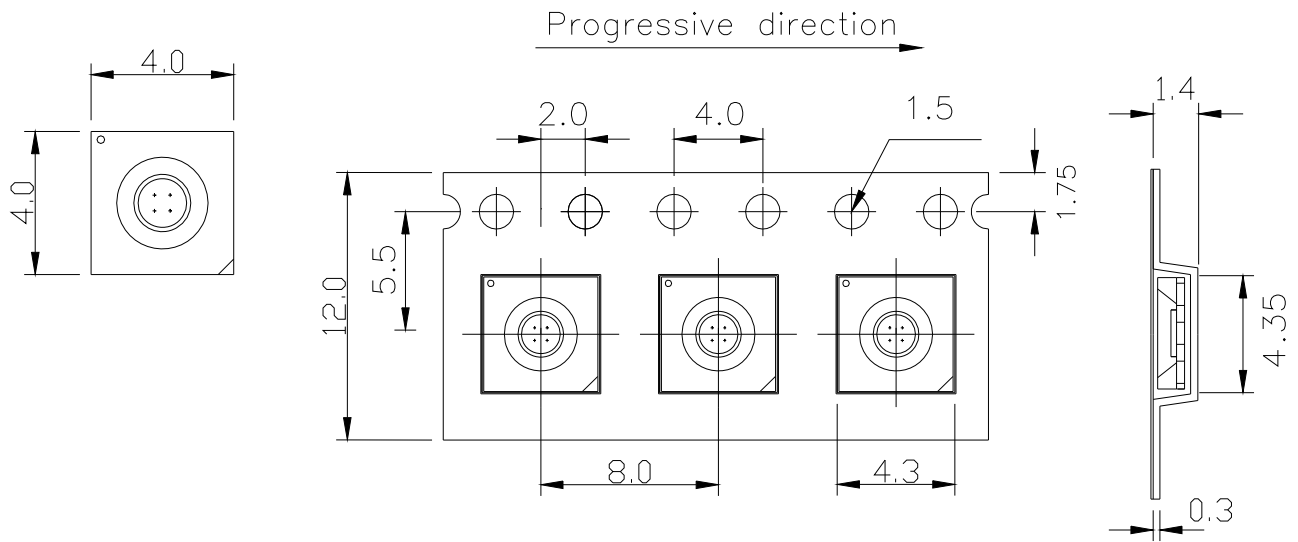

**Note:** The tolerances unless mentioned is  $\pm 0.1$ mm ,Unit = mm

**Moisture Resistant Packaging**

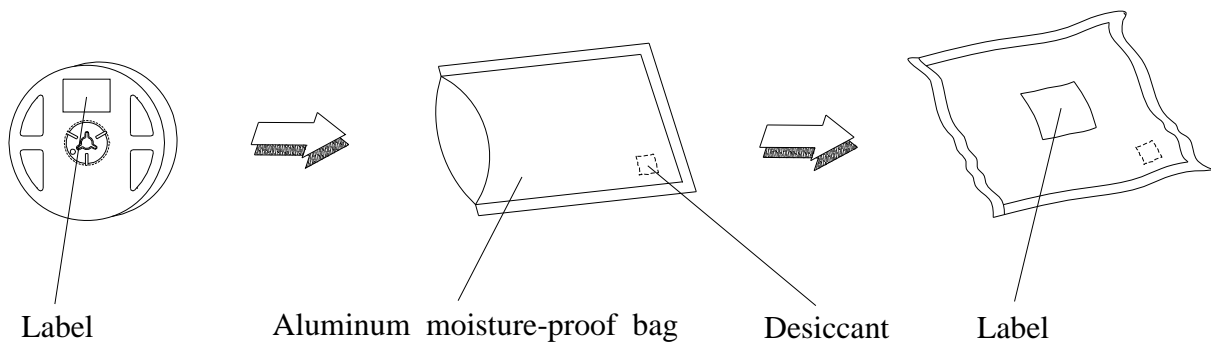

**Reliability Test Items And Conditions**

The reliability of products shall be satisfied with items listed below.

Confidence level : 90%

LTPD : 10%

No.	Items	Test Condition	Test Hours/Cycles	Sample Size	Ac/Re
1	Reflow Soldering	Temp. : 260°C±5°C Min. 5sec.	6 Min.	22 PCS.	0/1
2	Temperature Cycle	H : +100°C 15min ∫ 5 min L : -40°C 15min	300 Cycles	22 PCS.	0/1
3	Thermal Shock	H : +100°C 5min ∫ 10 sec L : -10°C 5min	300 Cycles	22 PCS.	0/1
4	High Temperature Storage	Temp. : 100°C	1000 Hrs.	22 PCS.	0/1
5	Low Temperature Storage	Temp. : -40°C	1000 Hrs.	22 PCS.	0/1
6	DC Operating Life	IF = 20 mA	1000 Hrs.	22 PCS.	0/1
7	High Temperature / High Humidity	85°C/ 85%RH	1000 Hrs.	22 PCS.	0/1



## Precautions For Use

### 1. Over-current-proof

Customer must apply resistors for protection, otherwise slight voltage shift will cause big current change ( Burn out will happen ).

### 2. Storage

2.1 Do not open moisture proof bag before the products are ready to use.

2.2 Before opening the package: The LEDs should be kept at 30°C or less and 90%RH or less.

2.3 After opening the package: The LED's floor life is 1 year under 30°C or less and 60% RH or less.

If unused LEDs remain, it should be stored in moisture proof packages.

2.4 If the moisture absorbent material (silica gel) has faded away or the LEDs have exceeded the storage time, baking treatment should be performed using the following conditions.

Baking treatment : 60±5°C for 24 hours.

### 3. Soldering Condition

#### 3.1 Pb-free solder temperature profile

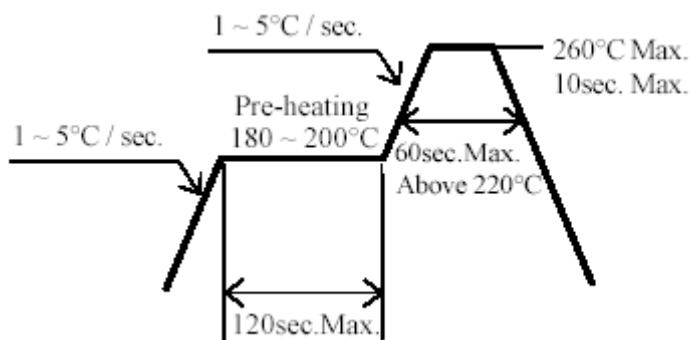

3.2 Reflow soldering should not be done more than two times.

3.3 When soldering, do not put stress on the LEDs during heating.

3.4 After soldering, do not warp the circuit board.

#### 4.Soldering Iron

Each terminal is to go to the tip of soldering iron temperature less than 350°C for 3 seconds within once in less than the soldering iron capacity 25W. Leave two seconds and more intervals, and do soldering of each terminal. Be careful because the damage of the product is often started at the time of the hand solder.

#### 5.Repairing

Repair should not be done after the LEDs have been soldered. When repairing is unavoidable, a double-head soldering iron should be used (as below figure). It should be confirmed beforehand whether the characteristics of the LEDs will or will not be damaged by repairing.

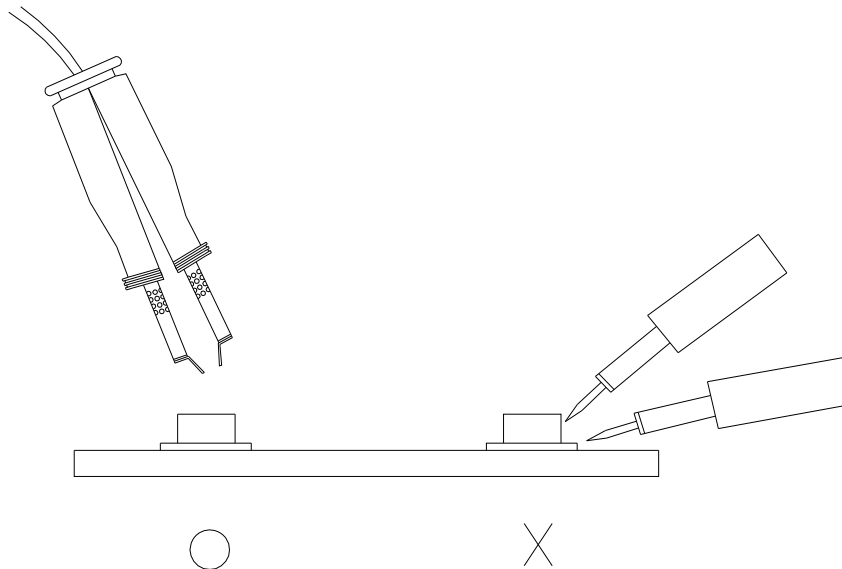

**EVERLIGHT ELECTRONICS CO., LTD.**

Office: No 25, Lane 76, Sec 3, Chung Yang Rd,  
Tucheng, Taipei 236, Taiwan, R.O.C

Tel: 886-2-2267-2000, 2267-9936

Fax: 886-2267-6244, 2267-6189, 2267-6306

<http://www.everlight.com>