



## Technical Data Sheet

### 1.5mm Side Face Infrared LED

#### IR908-7C-F

#### Features

- High reliability
- High radiant intensity
- Peak wavelength  $\lambda_p=940\text{nm}$
- 2.54mm Lead spacing
- Low forward voltage
- Pb free
- This product itself will remain within RoHS compliant version.



#### Descriptions

- EVERLIGHT's Infrared Emitting Diode (IR908-7C-F) is a high intensity diode, molded in a water clear plastic package.
- The miniature side-facing device has a chip, that emits radiation from the side of the clear package.

#### Applications

- Mouse
- Optoelectronic switch
- Infrared applied system

#### Device Selection Guide

| LED Part No. | Chip     | Lens Color  |
|--------------|----------|-------------|
|              | Material |             |
| IR908-7C-F   | GaAlAs   | Water clear |

**Package Dimensions**

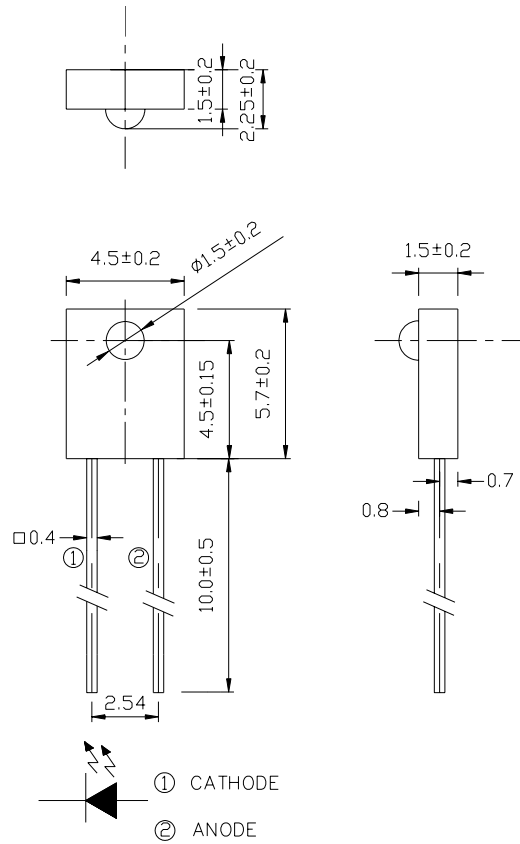

- Notes:** 1.All dimensions are in millimeters  
 2.Tolerances unless dimensions  $\pm 0.25\text{mm}$

**Absolute Maximum Ratings (Ta=25°C)**

| Parameter   | Symbol    | Rating    | Units |
|---|-----------|-----------|-------|
| Continuous Forward Current                                  | $I_F$     | 50        | mA    |
| Peak Forward Current  | $I_{FP}$  | 1.0       | A     |
| Reverse Voltage   | $V_R$     | 5         | V     |
| Operating Temperature                                       | $T_{opr}$ | -25 ~ +85 | °C    |
| Storage Temperature   | $T_{stg}$ | -40 ~ +85 | °C    |
| Soldering Temperature                                       | $T_{sol}$ | 260       | °C    |
| Power Dissipation at(or below)<br>25°C Free Air Temperature | $P_d$     | 75        | mW    |

- Notes:** \*1: $I_{FP}$  Conditions--Pulse Width  $\leq 100 \mu s$  and Duty  $\leq 1\%$ .  
 \*2:Soldering time  $\leq 5$  seconds.

**Electro-Optical Characteristics (Ta=25°C)**

| Parameter          | Symbol         | Condition                                  | Min. | Typ. | Max. | Units |
|--------------------|----------------|--|------|------|------|-------|
| Light Current      | Ic(on)         | I <sub>F</sub> =4mA, V <sub>CE</sub> =3.5V | 143  | --   | 1274 | μA    |
| Peak Wavelength    | λ <sub>p</sub> | I <sub>F</sub> =20mA                       | --   | 940  | --   | nm    |
| Spectral Bandwidth | Δλ             | I <sub>F</sub> =20mA                       | --   | 45   | --   | nm    |
| Forward Voltage    | V <sub>F</sub> | I <sub>F</sub> =20mA                       |      | 1.2  | 1.5  | V     |
| Reverse Current    | I <sub>R</sub> | V <sub>R</sub> =5V                         | --   | --   | 10   | μA    |
| View Angle         | 2θ 1/2         | I <sub>F</sub> =20mA                       | --   | 60   | --   | deg   |

**Rank**

| Color Code | Ranks | Symbol | Min | Typ | Max | Unit | Test Condition                             |
|------------|-------|--------|-----|-----|-----|------|--|
| Red        | E1    | Ic(on) | 143 | --- | 255 | μA   | I <sub>F</sub> =4mA, V <sub>CE</sub> =3.5V |
| Blue       | E2    | Ic(on) | 214 | --- | 343 | μA   | I <sub>F</sub> =4mA, V <sub>CE</sub> =3.5V |
| Yellow     | E3    | Ic(on) | 286 | --- | 431 | μA   | I <sub>F</sub> =4mA, V <sub>CE</sub> =3.5V |
| Silver     | E4    | Ic(on) | 357 | --- | 519 | μA   | I <sub>F</sub> =4mA, V <sub>CE</sub> =3.5V |
| Green      | E5    | Ic(on) | 428 | --- | 608 | μA   | I <sub>F</sub> =4mA, V <sub>CE</sub> =3.5V |
| Purple     | E6    | Ic(on) | 500 | --- | 696 | μA   | I <sub>F</sub> =4mA, V <sub>CE</sub> =3.5V |
| White      | E7    | Ic(on) | 571 | --- | 784 | μA   | I <sub>F</sub> =4mA, V <sub>CE</sub> =3.5V |

**Rough ranks**

| Parameter | Min | Max  | Unit | Test Condition                             |
|-----------|-----|------|------|--|
| 7-2       | 306 | 441  | μA   | I <sub>F</sub> =4mA, V <sub>CE</sub> =3.5V |
| 7-1       | 347 | 550  | μA   | I <sub>F</sub> =4mA, V <sub>CE</sub> =3.5V |
| 6-2       | 465 | 750  | μA   | I <sub>F</sub> =4mA, V <sub>CE</sub> =3.5V |
| 6-1       | 650 | 1274 | μA   | I <sub>F</sub> =4mA, V <sub>CE</sub> =3.5V |

**Typical Electro-Optical Characteristics Curves**

Fig.1 Forward Current vs. Ambient Temperature

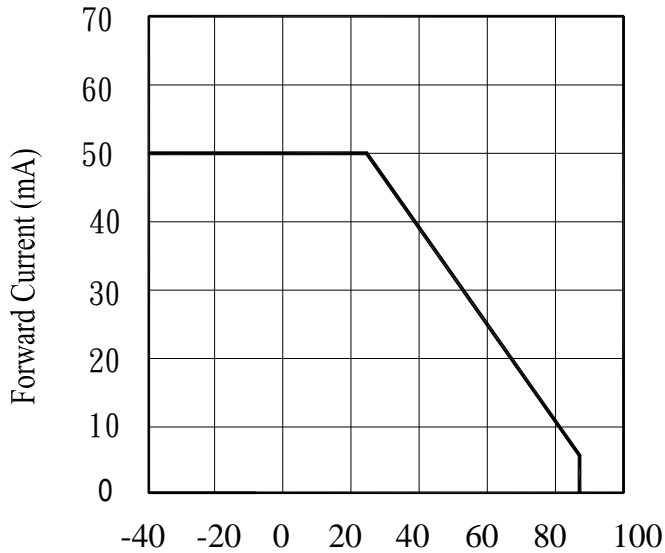

Fig.2 Spectral Distribution

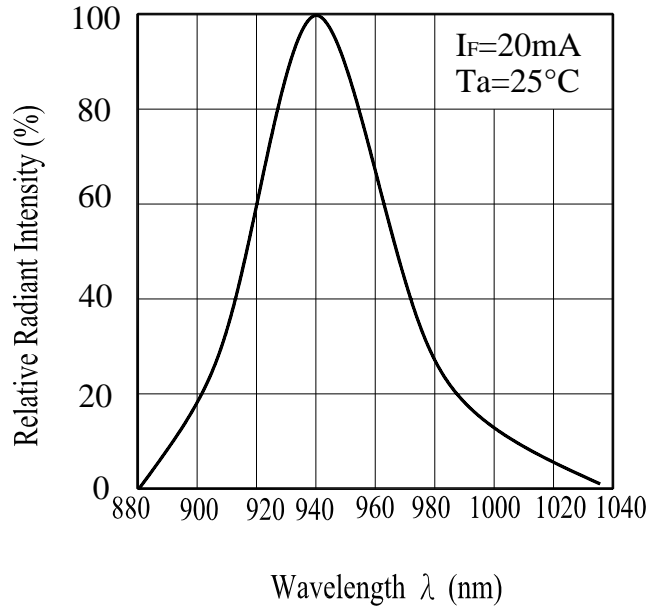

Fig.3 Peak Emission Wavelength vs. Ambient Temperature

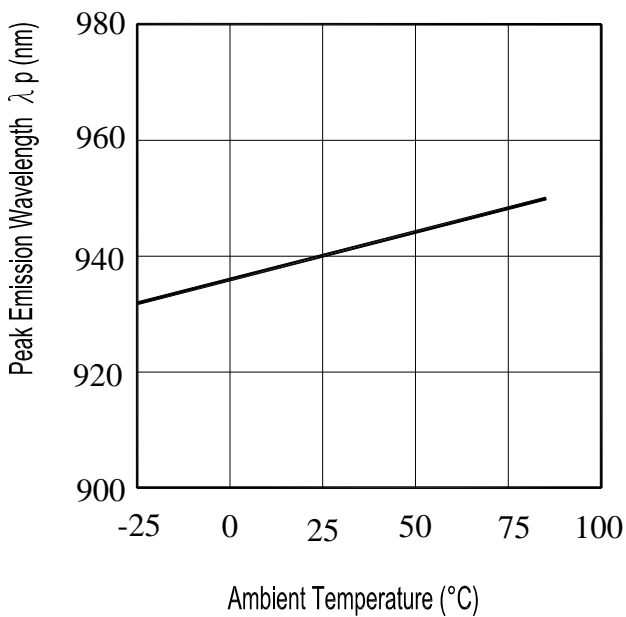
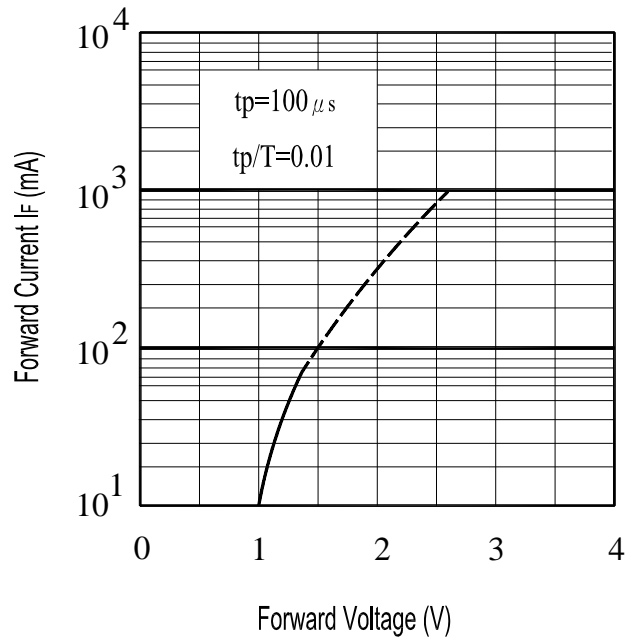

Fig.4 Forward Current vs. Forward Voltage



**Typical Electro-Optical Characteristics Curves**

Fig.8 Forward Current vs. Ambient Temperature(°C)

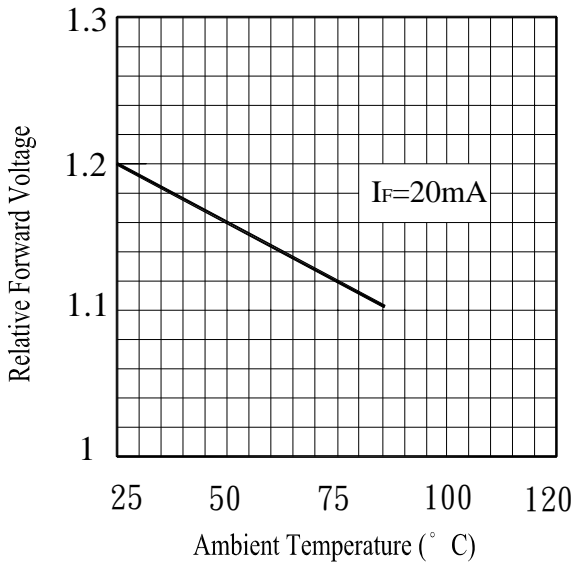
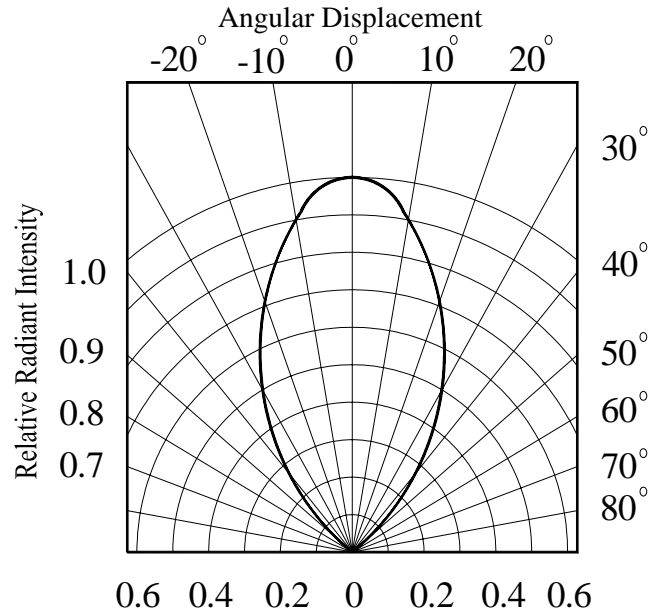

Fig.6 Relative Radiant Intensity vs. Angular Displacement



**Test Method For  $I_{C(ON)}$ :**

Condition:  $I_F=4mA, V_{CE}=3.5V$

The intensity testing method for infrared emitting diode

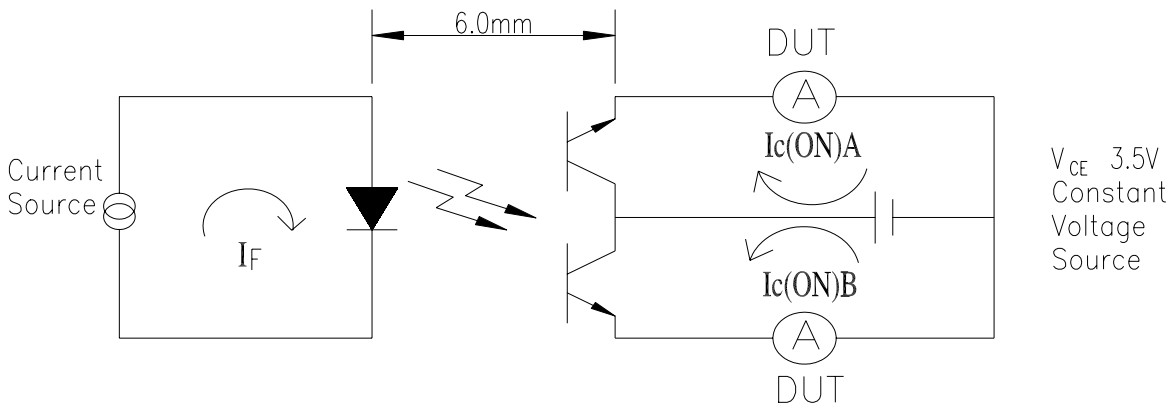







**Packing Quantity Specification**

- 1. 1000PCS/1Bag,10Bag/1Box
- 2. 10Boxes/1Carton

**Label Form Specification**

|   |  |                                   |
|---|--|-----------------------------------|
|  |  |                                   |
| CPN:  |  | CPN: Customer's Production Number |
| P/N:  |  | P/N : Production Number           |
|  |   | QTY: Packing Quantity             |
| IR908-7C-F  |  | CAT: Ranks                        |
| QTY:  |   | HUE: Peak Wavelength              |
| LOT NO:   |  | REF: Reference                    |
|   |  | LOT No: Lot Number                |

**Notes**

- 1. Above specification may be changed without notice. EVERLIGHT will reserve authority on material change for above specification.
- 2. When using this product, please observe the absolute maximum ratings and the instructions for using outlined in these specification sheets. EVERLIGHT assumes no responsibility for any damage resulting from use of the product which does not comply with the absolute maximum ratings and the instructions included in these specification sheets.
- 3. These specification sheets include materials protected under copyright of EVERLIGHT corporation. Please don't reproduce or cause anyone to reproduce them without EVERLIGHT's consent.

|   |  |
|---|--|
| <b>EVERLIGHT ELECTRONICS CO., LTD.</b><br>Office: No 25, Lane 76, Sec 3, Chung Yang Rd,<br>Tucheng, Taipei 236, Taiwan, R.O.C | Tel: 886-2-2267-2000, 2267-9936<br>Fax: 886-2267-6244, 2267-6189, 2267-6306<br><a href="http://www.everlight.com">http://www.everlight.com</a> |
|---|--|