



# Technical Data Sheet

## Side Face Silicon Phototransistor

### PT5529B/L2-F

#### Features

- Fast response time
- High photo sensitivity
- Pb free
- This product itself will remain within RoHS compliant version.

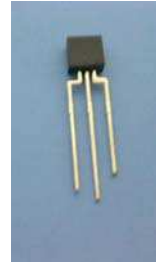

#### Descriptions

- PT5529B/L2-F is a high speed and high sensitive dual phototransistor molded in a black plastic package with plat side view.
- The device is spectrally matched with IR emitters.

#### Applications

- Mouse
- Optoelectronic Switch
- Photo Interrupter

#### Device Selection Guide

LED Part No.	Chip	Lens Color
	Material	
PT5529B/L2-F	Silicon	Black

..

**Package Dimensions**

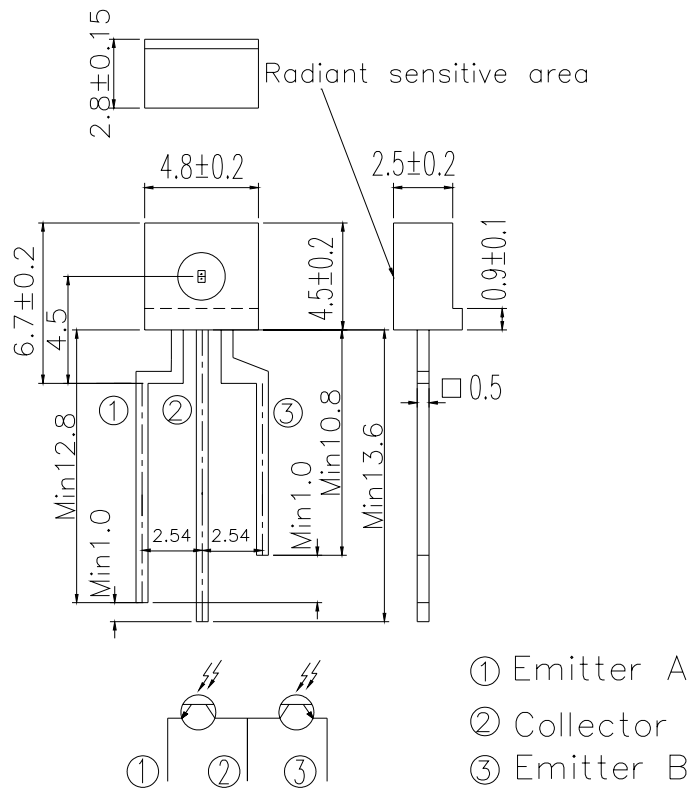

- Notes:** 1.All dimensions are in millimeters  
 2.Tolerances unless dimensions  $\pm 0.25$ mm

**Absolute Maximum Ratings (Ta=25°C)**

Parameter	Symbol	Rating	Units
Collector-Emitter Voltage	V <sub>CEO</sub>	30	V
Emitter-Collector-Voltage	V <sub>ECO</sub>	5	V
Collector Current	I <sub>C</sub>	20	mA
Operating Temperature	T <sub>opr</sub>	-25 ~ +85°C	°C
Storage Temperature	T <sub>stg</sub>	-40 ~ +85°C	°C
Lead Soldering Temperature(*1)	T <sub>sol</sub>	260	°C
Power Dissipation at (or below) 25°C Free Air Temperature	P <sub>D</sub>	75	mW

**Notes:** \*1:Soldering time  $\leq 5$  seconds.

**Electro-Optical Characteristics (Ta=25°C)**

Parameter	Symbol	Condition	Min	Typ	Max	Unit
Collector – Emitter Breakdown Voltage	$BV_{CEO}$	$I_C=100\ \mu A$ $E_e=0mW/cm^2$	30	---	---	V
Emitter-Collector Breakdown Voltage	$BV_{ECO}$	$I_E=100\ \mu A$ $E_e=0mW/cm^2$	5	---	---	V
Collector-Emitter Saturation Voltage	$V_{CE(sat)}$	$I_C=2mA$ $E_e=1mW/cm^2$	---	---	0.4	V
Rise Time	$t_r$	$V_{CE}=5V$ $I_C=1mA$ $R_L=1000\ \Omega$	---	15	---	$\mu S$
Fall Time	$t_f$		---	15	---	
Collector Dark Current	$I_{CEO}$	$E_e=0mW/cm^2$ $V_{CE}=20V$	---	---	100	nA
On State Collector Current	$I_{C(on)}$	$V_{CE}=5V$ , $E_e=0.555mW/cm^2$	129	---	1085	$\mu A$
Wavelength of Peak Sensitivity	$\lambda_p$	---	---	940	---	nm
Rang of Spectral Bandwidth	$\lambda_{0.5}$	---	760	---	1100	nm

**Typical Electro-Optical Characteristics Curves**

Fig.1 Power Dissipation vs. Ambient Temperature

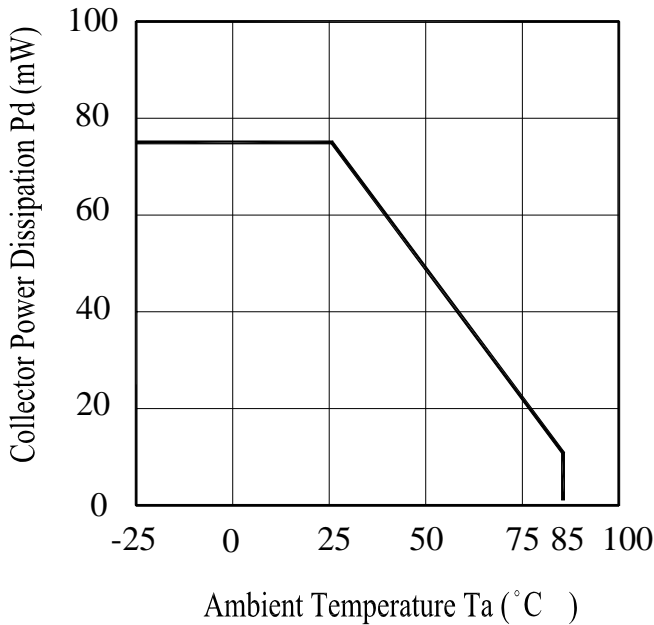

Fig.2 Spectral Sensitivity

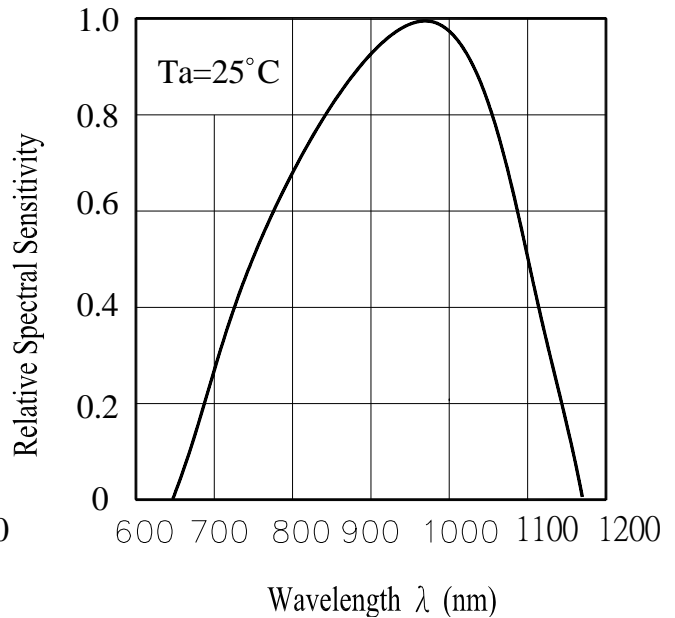

Fig.3 Dark Current vs. Ambient Temperature

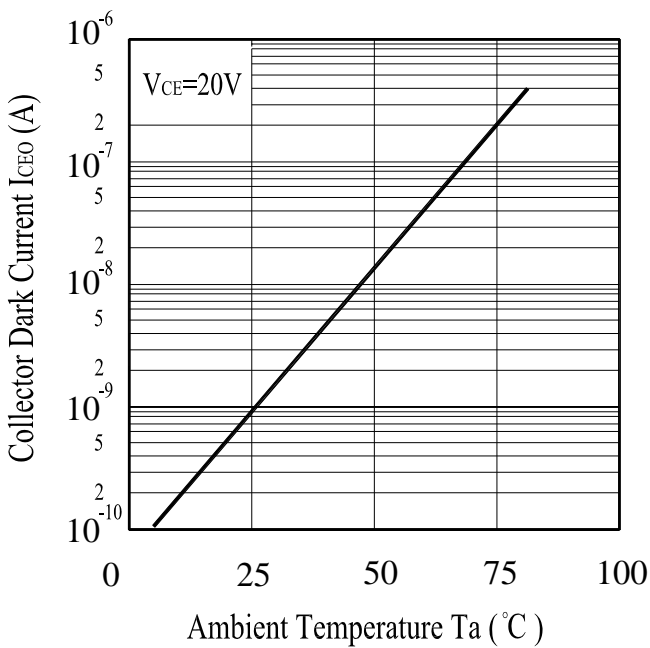
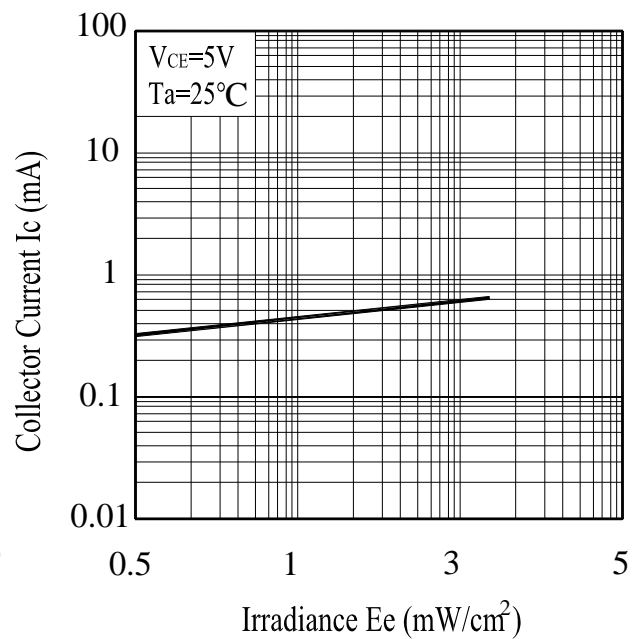

Fig. 4 Reverse Light Current vs. Ee



**Typical Electro-Optical Characteristics Curves**

Fig.5 Terminal Capacitance vs. Reverse Voltage

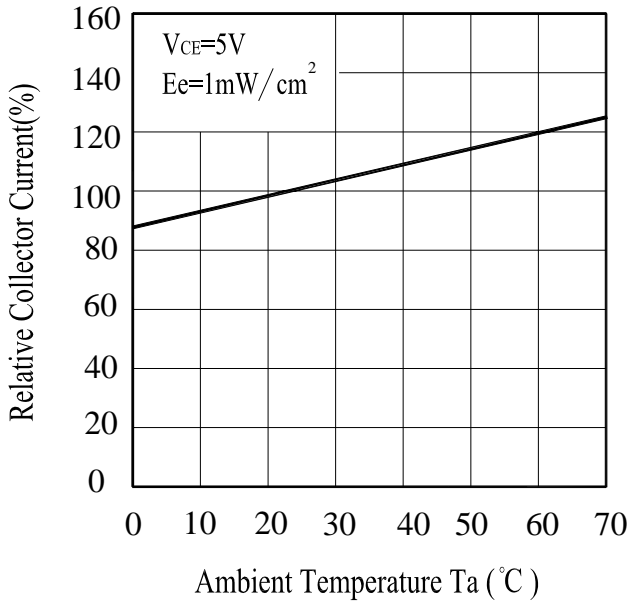
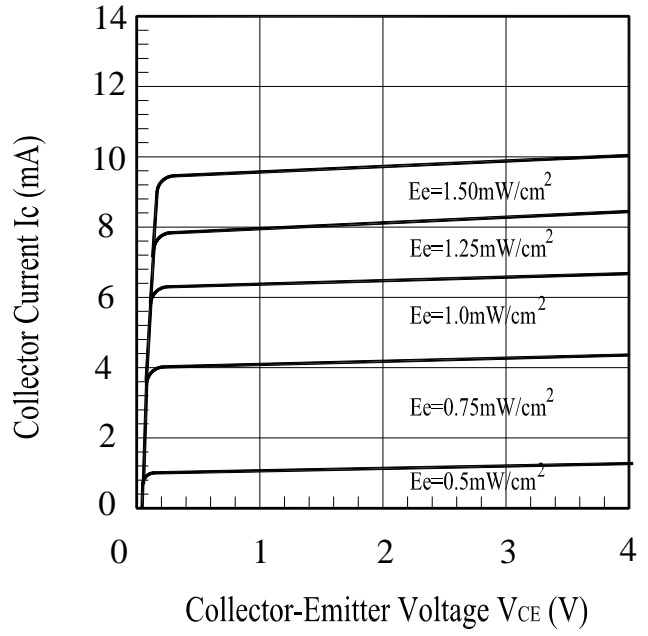

Fig.6 Response Time vs. Load Resistance





**Test Method For On State Collector Current :**

Condition :  $E_e=0.555\text{mW/cm}^2$  ,  $V_{CE}=5\text{V}$

Test Item : Collector Current [ $I_{C(on)}$ ]

Unit :  $\mu\text{A}$

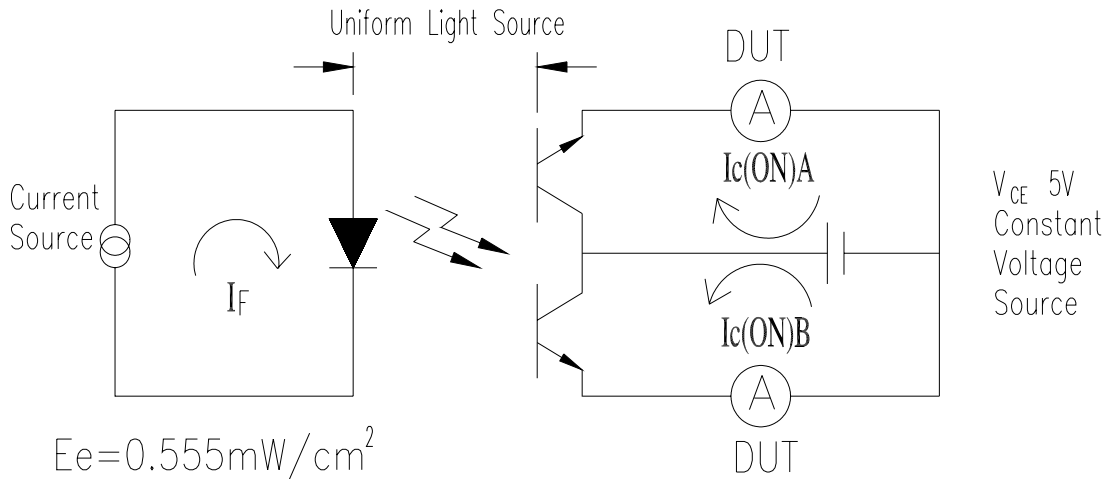

**To Distinguish Intensity:**

Condition:  $V_{CE}=5\text{V}$   $E_e=0.555\text{mW/cm}^2$

**A Ranks**

Color Code	Ranks	Symbol	Min	Typ	Max	Unit	Test Condition
Red	A1	$I_{C(ON)}$	129	---	226	$\mu\text{A}$	$E_e=0.555\text{mW/c m}^2$ $V_{CE}=5\text{V}$
Blue	A2	$I_{C(ON)}$	195	---	306	$\mu\text{A}$	$E_e=0.555\text{mW/c m}^2$ $V_{CE}=5\text{V}$
Yellow	A3	$I_{C(ON)}$	262	---	380	$\mu\text{A}$	$E_e=0.555\text{mW/c m}^2$ $V_{CE}=5\text{V}$
Silver	A4	$I_{C(ON)}$	330	---	461	$\mu\text{A}$	$E_e=0.555\text{mW/c m}^2$ $V_{CE}=5\text{V}$
Green	A5	$I_{C(ON)}$	398	---	544	$\mu\text{A}$	$E_e=0.555\text{mW/c m}^2$ $V_{CE}=5\text{V}$
Purple	A6	$I_{C(ON)}$	468	---	625	$\mu\text{A}$	$E_e=0.555\text{mW/c m}^2$ $V_{CE}=5\text{V}$
White	A7	$I_{C(ON)}$	536	---	703	$\mu\text{A}$	$E_e=0.555\text{mW/c m}^2$ $V_{CE}=5\text{V}$
Brown	A8	$I_{C(ON)}$	604	---	785	$\mu\text{A}$	$E_e=0.555\text{mW/c m}^2$ $V_{CE}=5\text{V}$
Orange	A9	$I_{C(ON)}$	673	---	862	$\mu\text{A}$	$E_e=0.555\text{mW/c m}^2$ $V_{CE}=5\text{V}$
Golden	A10	$I_{C(ON)}$	742	---	944	$\mu\text{A}$	$E_e=0.555\text{mW/c m}^2$ $V_{CE}=5\text{V}$
Pink	A11	$I_{C(ON)}$	812	---	1018	$\mu\text{A}$	$E_e=0.555\text{mW/c m}^2$ $V_{CE}=5\text{V}$
Red,Blue	A12	$I_{C(ON)}$	882	---	1085	$\mu\text{A}$	$E_e=0.555\text{mW/c m}^2$ $V_{CE}=5\text{V}$



### **Packing Quantity Specification**

- 1. 1000Pcs/1Bag , 8Bags/1Box
- 2. 10Boxes/1Carton



CPN:

P/N:



PT5529B/L2-F

QTY:



LOT NO:



CAT:

HUE:

REF:

### **Label Form Specification**

CPN: Customer's Production Number

P/N : Production Number

QTY: Packing Quantity

CAT: Ranks

HUE: Peak Wavelength

REF: Reference

LOT No: Lot Number

### **Notes**

- 1. Above specification may be changed without notice. EVERLIGHT will reserve authority on material change for above specification.
- 2. When using this product, please observe the absolute maximum ratings and the instructions for using outlined in these specification sheets. EVERLIGHT assumes no responsibility for any damage resulting from use of the product which does not comply with the absolute maximum ratings and the instructions included in these specification sheets.
- 3. These specification sheets include materials protected under copyright of EVERLIGHT corporation. Please don't reproduce or cause anyone to reproduce them without EVERLIGHT's consent.

**EVERLIGHT ELECTRONICS CO., LTD.**

Office: No 25, Lane 76, Sec 3, Chung Yang Rd,

Tucheng, Taipei 236, Taiwan, R.O.C

Tel: 886-2-2267-2000, 2267-9936

Fax: 886-2267-6244, 2267-6189, 2267-6306

<http://www.everlight.com>