

## Technical Data Sheet

### 1.4 mm Height Subminiature , Axial Flat Top View LED

#### 28-21UYC/S530-XX/XXX

#### Features

- Package in 12mm tape on 7" diameter reels.
- Compatible with automatic placement equipment.
- EIA Std. package.
- Mono-color type.
- Pb-free
- The product itself will remain within RoHS compliant version.



#### Descriptions

- The 28-21 SMD LED is much smaller than leaded components. Thus enable smaller board size. Higher packing density. Reduced storage space and finally smaller equipment to be obtained.
- Besides, light weight makes them ideal for miniature applications.
- Furthermore by automation assembly machines the accuracy is anticipated.

F8/TR8

28-21

#### Applications

- Small indicator for indoor applications.
- Flat backlight for LCD, switches and symbols.
- Indicator and backlight in office equipment.
- Indicator and backlight for battery driven equipment.
- Indicator and backlight for audio and video equipment.
- Automotive : backlighting in dashboards and switches
- Telecommunication : indicator and backlighting in telephone and fax.

#### Device Selection Guide

Part No.	Chip		Lens Color
	Material	Emitted Color	
28-21UYC/S530-XX/XXX	AlGaInP	Brilliant Yellow	Water Clear

**28-21UYC/S530-XX/XXX**

**Package Outline Dimensions**

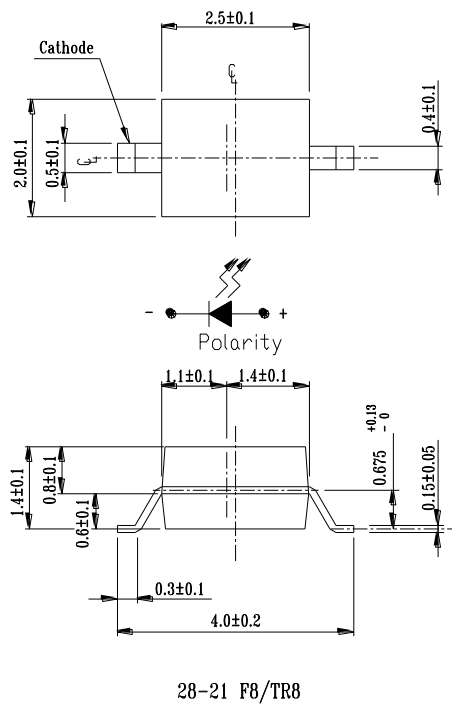
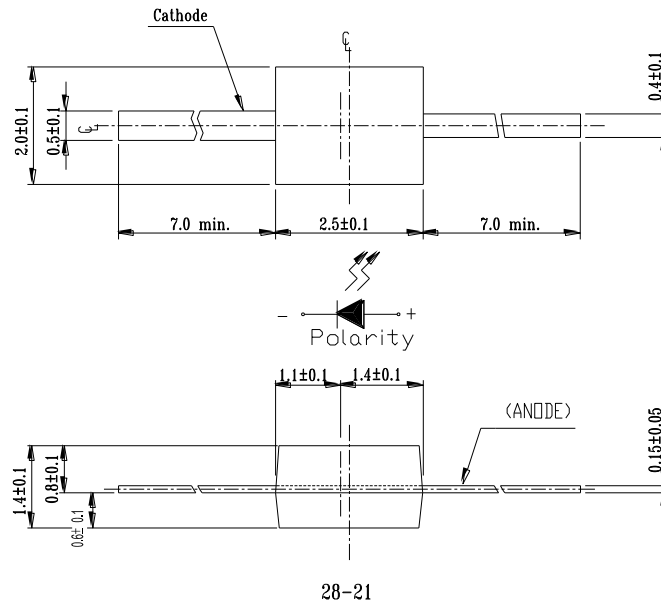

Note :  
Tolerances unless dimension  $\pm 0.1$   
Angle  $\pm 5$   
Unit : mm

**Note:** Tolerances Unless Dimension is  $\pm 0.1$ mm , Unit = mm

**28-21UYC/S530-XX/XXX**

**Absolute Maximum Ratings (Ta=25°C)**

Parameter	Symbol	Rating	Unit
Reverse Voltage	V <sub>R</sub>	5	V
Forward Current	I <sub>F</sub>	25	mA
Peak Forward Current(Duty 1/10 @ 1KHz)	I <sub>FP</sub>	60	mA
Power Dissipation	P <sub>d</sub>	60	mW
Electrostatic Discharge	ESD	2000	V
Operating Temperature	T <sub>opr</sub>	-40 ~ +85	°C
Storage Temperature	T <sub>stg</sub>	-40 ~ +100	°C
Soldering Temperature	T <sub>sol</sub>	Reflow Soldering : 260 °C for 10 sec. Hand Soldering : 350 °C for 3 sec.	

**Electro-Optical Characteristics (Ta=25°C)**

Parameter	Symbol	Chip Rank	MIN.	TYP.	MAX.	Unit	Condition
Luminous Intensity	I <sub>v</sub>	A2	12.0	30.0	----	mcd	I <sub>F</sub> =20mA
		A3	21.0	33.0	----		
		A4	34.0	45.0	----		
		A5	42.0	61.0	----		
		A6	53.0	77.0	----		
		A7	66.0	91.0	----		
Viewing Angle	2θ 1/2	----	----	150	----	deg	
Peak Wavelength	λ <sub>p</sub>	----	----	591	----	nm	
Dominant Wavelength	λ <sub>d</sub>	----	----	589	----	nm	
Spectrum Radiation Bandwidth	Δλ	----	----	15	----	nm	
Forward Voltage	V <sub>F</sub>	----	1.7	2.0	2.4	V	
Reverse Current	I <sub>R</sub>	----	----	----	10	μA	V <sub>R</sub> =5V

**Notes:**

**Tolerance of Luminous Intensity ±11%**

**28-21UYC/S530-XX/XXX**

**Typical Electro-Optical Characteristics Curves**

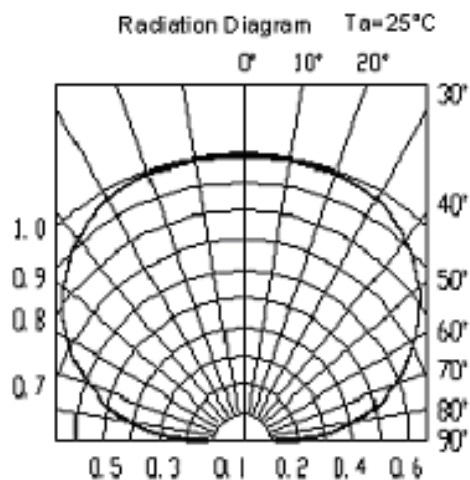
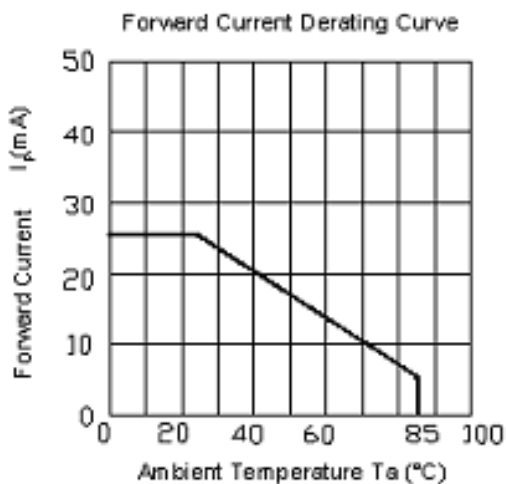
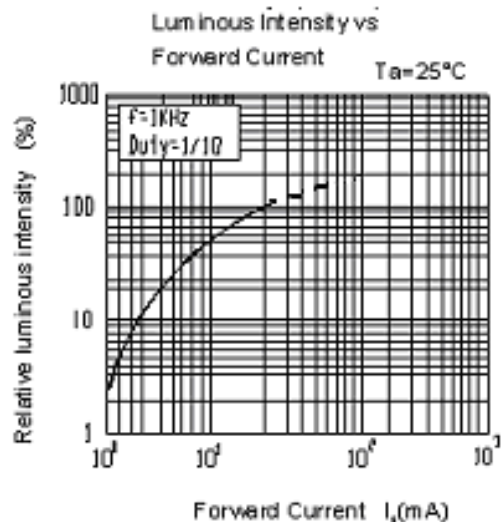
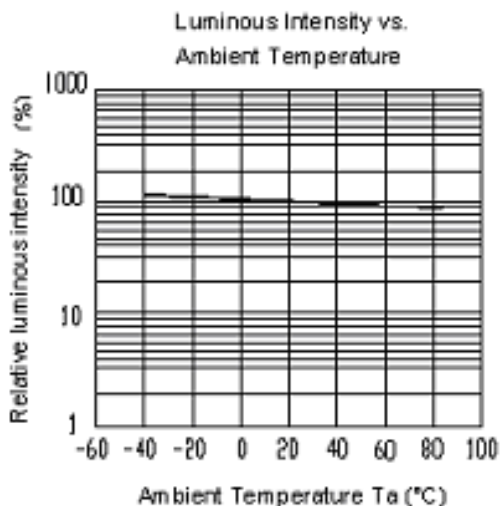
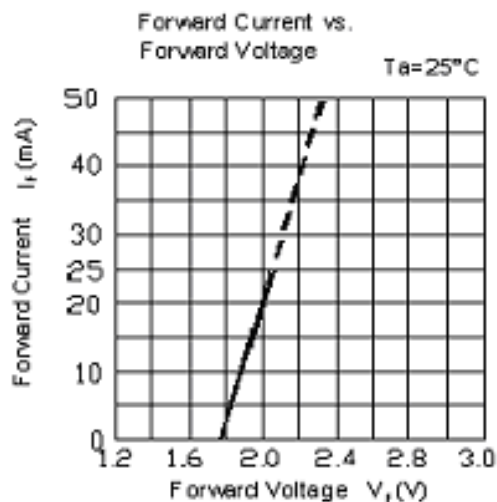
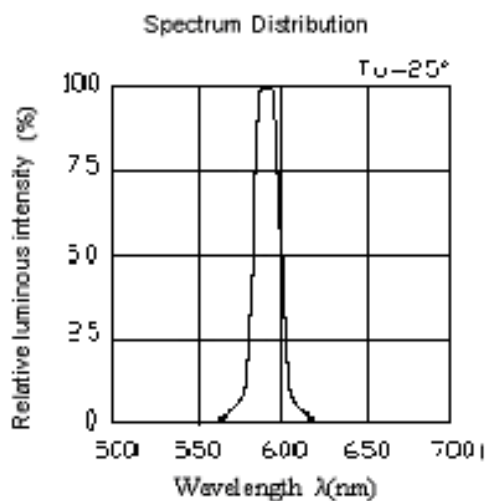

**28-21UYC/S530-XX/XXX**

**Material Descriptions**

**28-21 UYC / S530-XX / XXX**

1      2      3      4

- 1.production part no.:28-21
- 2.chip part no.& epoxy color  
AlGaInP =UY...  
C = water clear
- 3.chip size: S530 (9mil)  
chip rank:A2~A7
- 4.packing method:  
(1)NONE,F8 : Bulk  
(2) TR8 : Taping

**Label explanation**

**CAT: Luminous Intensity (mcd)**

**HUE: Dom. Wavelength (nm)**

**REF: Forward Voltage (V)**

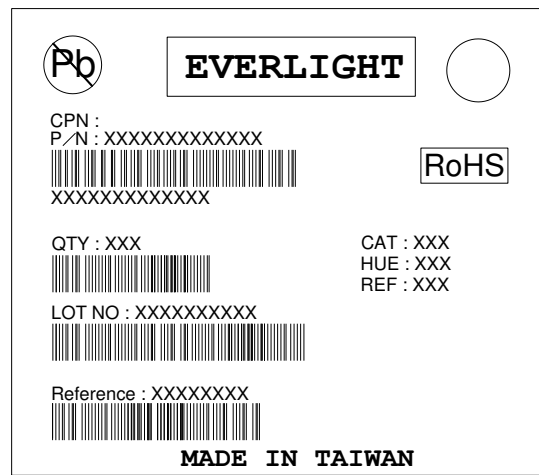

**Reel & Carrier Tape Dimensions**

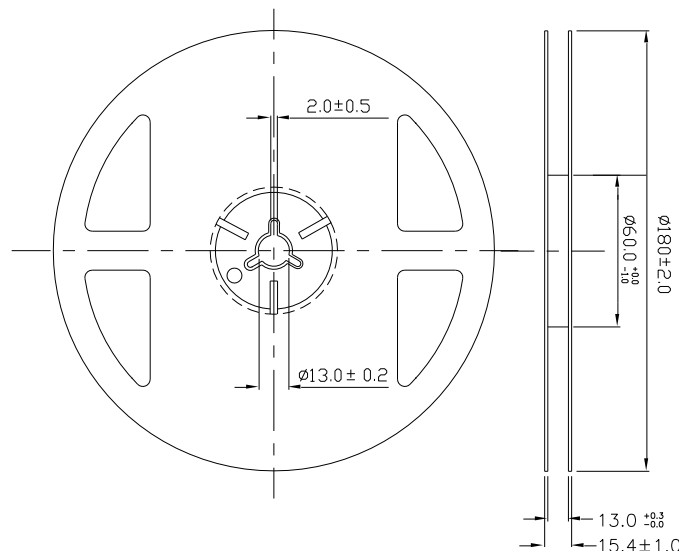

**Note:** Tolerances Unless Dimension is  $\pm 0.1\text{mm}$  , Unit = mm

**28-21UYC/S530-XX/XXX**

Loaded quantity per reel 1000 PCS/reel

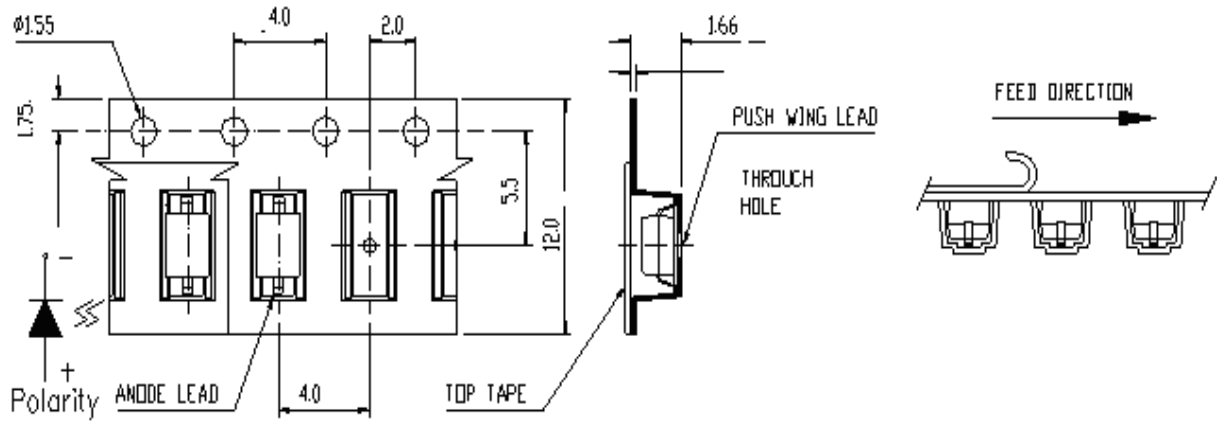

**Note:** Tolerances Unless Dimension is  $\pm 0.1$ mm , Unit = mm

**Moisture Resistant Packaging**

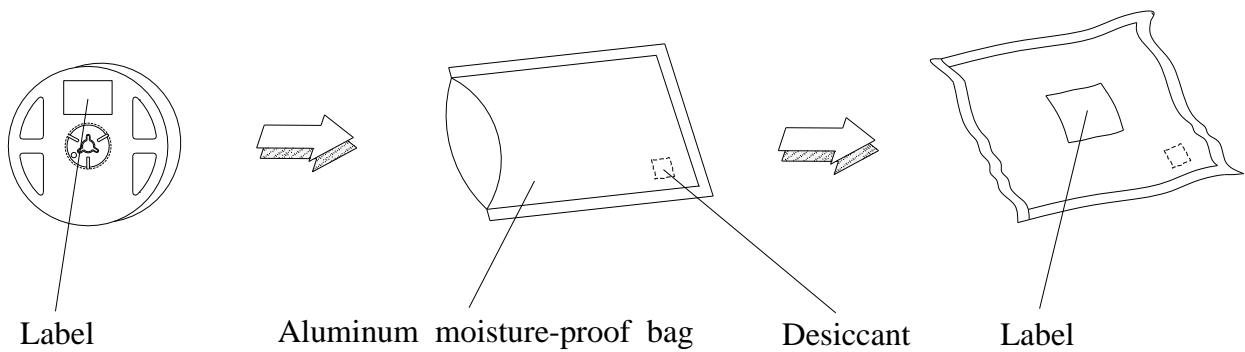

**28-21UYC/S530-XX/XXX**

**Reliability Test Items And Conditions**

The reliability of products shall be satisfied with items listed below.

Confidence level :

LTPD : 10 %

No.	Items	Test Condition	Test Hours/Cycles	Sample Size	Ac/Re
1	Reflow Soldering	Temp. : 260°C±5°C Min. 5 sec.	6 Min.	22 Pcs.	0/1
2	Temperature Cycle	H : +100°C 15 min. ∫ 5 min. L : -40°C 15 min.	300 Cycles	22 Pcs.	0/1
3	Thermal Shock	H : +100°C 5 min. ∫ 10 sec. L : -10°C 5 min.	300 Cycles	22 Pcs.	0/1
4	High Temperature Storage	Temp. : 100°C	1000 Hrs.	22 Pcs.	0/1
5	Low Temperature Storage	Temp. : -40°C	1000 Hrs.	22 Pcs.	0/1
6	DC Operating Life	IF = 20 mA	1000 Hrs.	22 Pcs.	0/1
7	High Temperature / High Humidity	85°C / 85% RH	1000 Hrs.	22 Pcs.	0/1

## Precautions For Use

### 1. Over-current-proof

Customer must apply resistors for protection , otherwise slight voltage shift will cause big current change ( Burn out will happen ).

### 2. Storage

2.1 Do not open moisture proof bag before the products are ready to use.

2.2 Before opening the package: The LEDs should be kept at 30°C or less and 90%RH or less.

2.3 After opening the package: The LED's floor life is 1 year under 30°C or less and 60% RH or less.

If unused LEDs remain, it should be stored in moisture proof packages.

2.4 If the moisture absorbent material (silica gel) has faded away or the LEDs have exceeded the storage time, baking treatment should be performed using the following conditions.

Baking treatment : 60±5°C for 24 hours.

### 3. Soldering Condition

#### 3.1 Pb-free solder temperature profile

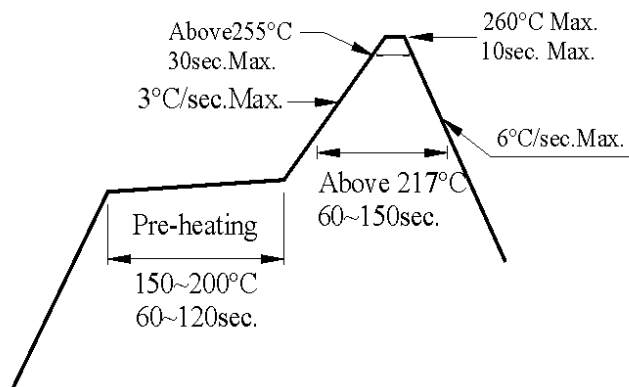

3.2 Reflow soldering should not be done more than two times.

3.3 When soldering, do not put stress on the LEDs during heating.

3.4 After soldering, do not warp the circuit board.



**28-21UYC/S530-XX/XXX**

4.Soldering Iron

Each terminal is to go to the tip of soldering iron temperature less than 350°C for 3 seconds within once in less than the soldering iron capacity 25W. Leave two seconds and more intervals, and do soldering of each terminal. Be careful because the damage of the product is often started at the time of the hand solder.

5.Repairing

Repair should not be done after the LEDs have been soldered. When repairing is unavoidable, a double-head soldering iron should be used (as below figure). It should be confirmed beforehand whether the characteristics of the LEDs will or will not be damaged by repairing.

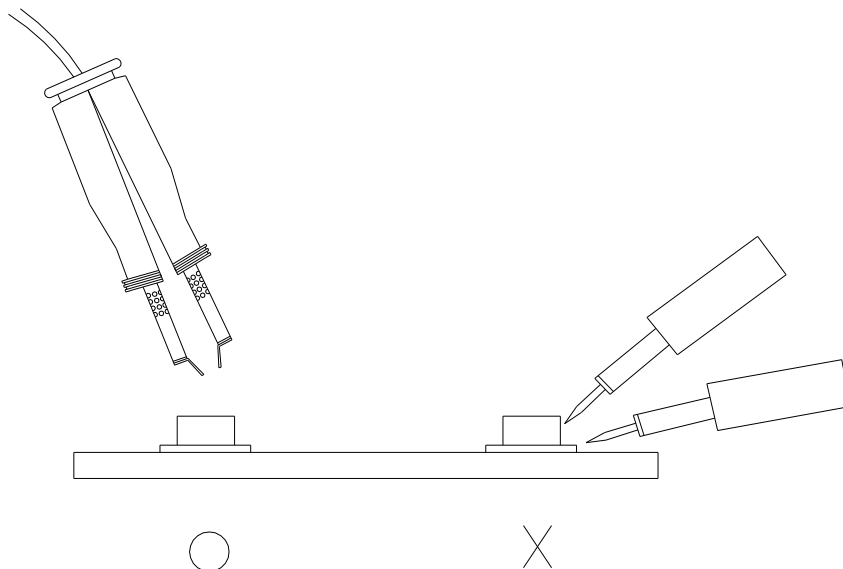

**EVERLIGHT ELECTRONICS CO., LTD.**

Office: No 25, Lane 76, Sec 3, Chung Yang Rd,  
Tucheng, Taipei 236, Taiwan, R.O.C

Tel: 886-2-2267-2000, 2267-9936

Fax: 886-2267-6244, 2267-6189, 2267-6306

<http://www.everlight.com>