

Technical Data Sheet

1.9mm Round Subminiature Lead LEDs

91-21SUGC/S400-XX/XXX

Features

- Package in 12mm tape on 7" diameter reels.
- Compatible with automatic placement equipment.
- EIA Std. package.
- Mono-color type.
- Pb-free

Descriptions

- The 91-21 SMD taping is much smaller than leaded components . Thus enable smaller board size. Higher packing density. Reduced storage space and finally smaller equipment to be obtained.
- Besides, light weight makes them ideal for miniature applications.
- Furthermore by automation assembly machines the accuracy is anticipated.

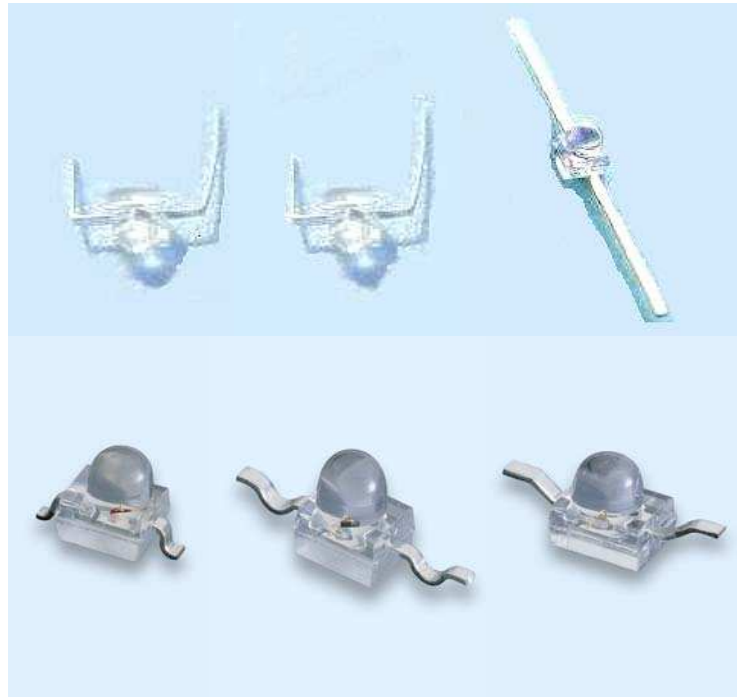

Applications

- Small indicator for indoor applications.
- Flat backlight for LCD, switches and symbols.
- Indicator and backlight in office equipment.
- Indicator and backlight for battery driven equipment.
- Indicator and backlight for audio and video equipment.
- Automotive : backlighting in dashboards and switches.
- Telecommunication : indicator and backlighting in telephone and fax.

Device Selection Guide

Chip		Lens Color
Material	Emitted Color	
InGaN	Super Green	Water Clear

91-21SUGC/S400-XX/XXX

Package Outline Dimensions

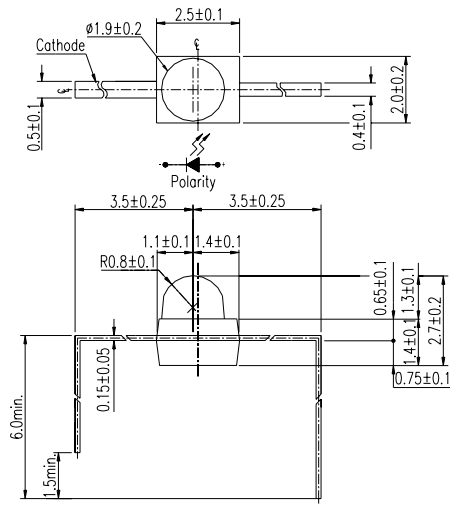

91-21/F1

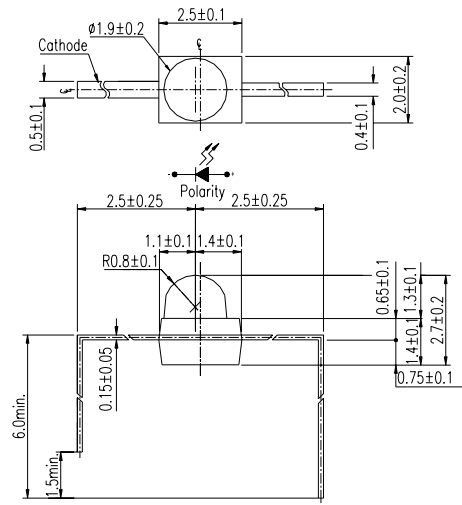

91-21/F2

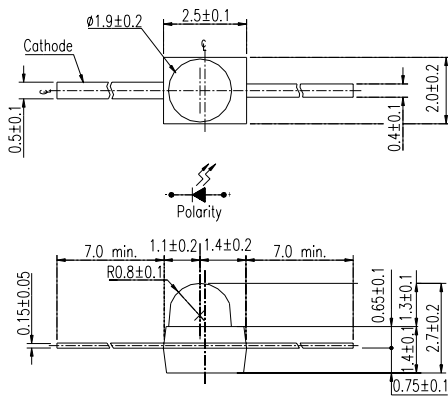

91-21

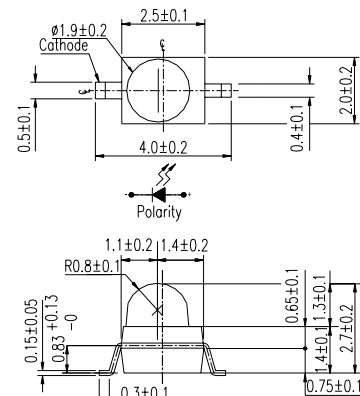

91-21F7/TR7

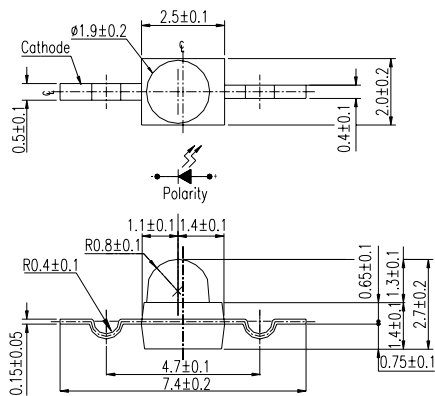

91-21F9/TR9

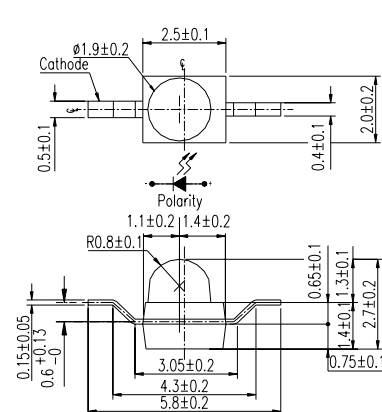

91-21F10/TR10

91-21SUGC/S400-XX/XXX

Absolute Maximum Ratings (Ta=25°C)

Parameter	Symbol	Rating	Unit
Reverse Voltage	V _R	5	V
Forward Current	I _F	25	mA
Operating Temperature	T _{opr}	-40 ~ +85	°C
Storage Temperature	T _{stg}	-40 ~ +100	°C
Soldering Temperature	T _{sol}	260 for 5 Sec.	°C
Electrostatic Discharge	ESD	150	V
Power Dissipation	P _d	110	mW
Peak Forward Current(Duty 1/10 @ 1KHz)	I _{FP}	100	mA

Electro-Optical Characteristics (Ta=25°C)

Parameter	Symbol	Chip Rank	MIN.	TYP.	MAX.	Unit	Condition
Luminous Intensity	I _v	A4	----	200	----	mcd	I _F =2mA
			2000	2300	----		I _F =20mA
		A5	----	235	----		I _F =2mA
			2400	2850	----		I _F =20mA
		A6	----	260	----		I _F =2mA
			2800	3150	----		I _F =20mA
Viewing Angle	2θ 1/2	----	----	25	----	deg	I _F =20mA
Peak Wavelength	λ _p	----	----	518	----	nm	
Dominant Wavelength	λ _d	----	----	525	----	nm	
Spectrum Radiation Bandwidth	△λ	----	----	35	---	nm	
Forward Voltage	V _F	----	----	3.5	4.3	V	
Reverse Current	I _R	----	----	----	50	μA	V _R =5V

*91-21SUGC/S400- XX / XXX

1 2

1:Chip Rank

2:Packing Method:

(1) None,F1,F2, F7,F9,F10 : Bulk

(2) TR7,TR9,TR10 : Taping

Typical Electro-Optical Characteristics Curves

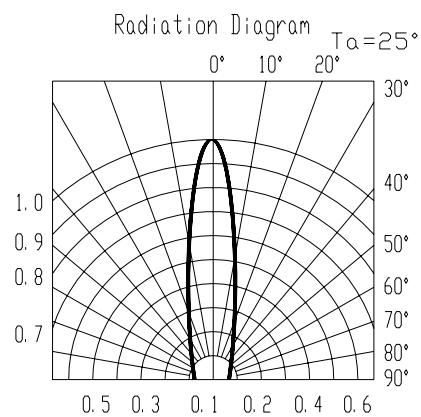
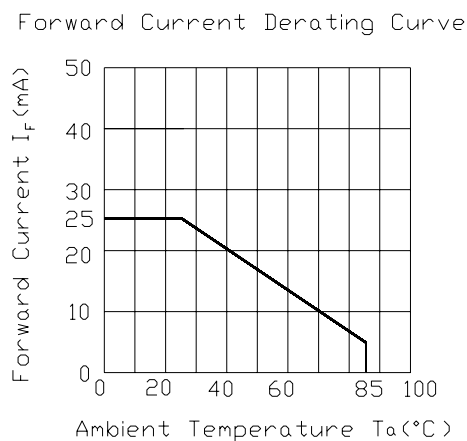
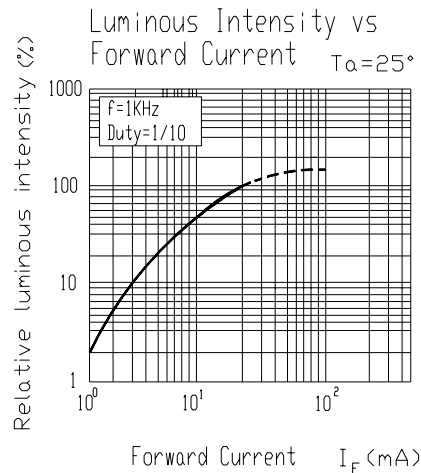
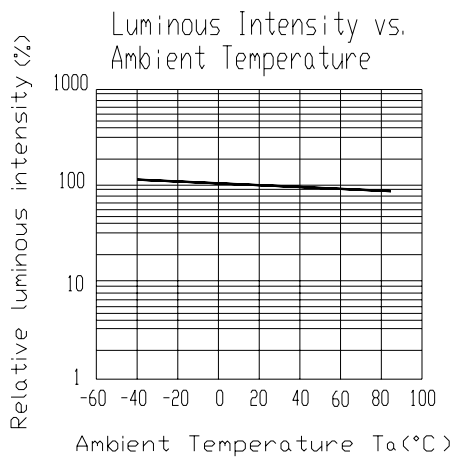
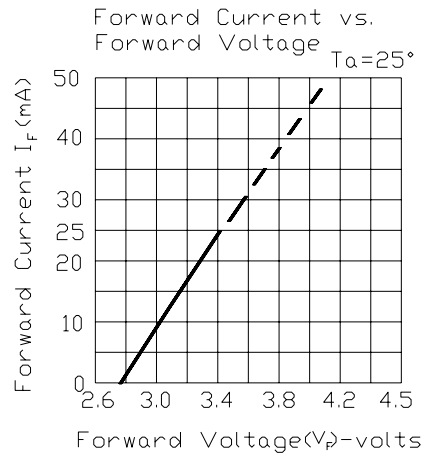
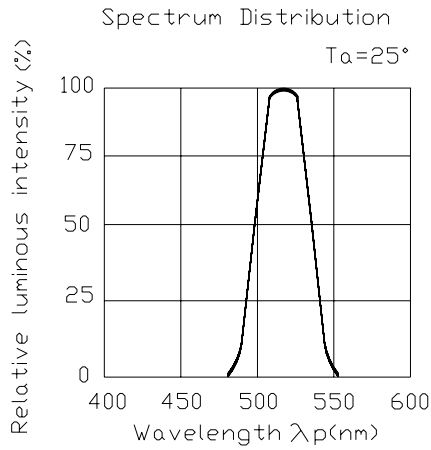

91-21SUGC/S400-XX/XXX

Label explanation

CAT: Luminous Intensity Rank

HUE: Dom. Wavelength Rank

REF: Forward Voltage Rank

EVERLIGHT

CPN :
P/N: XXXXXXXXXXXX



XX-XXXXXXXX CAT: Bin Iv
QTY: XXXX HUE: Bin λd
REF: Bin VF



LOT NO: XXXXXXXXX



MADE IN TAIWAN

Reel & Carrier Tape Dimensions

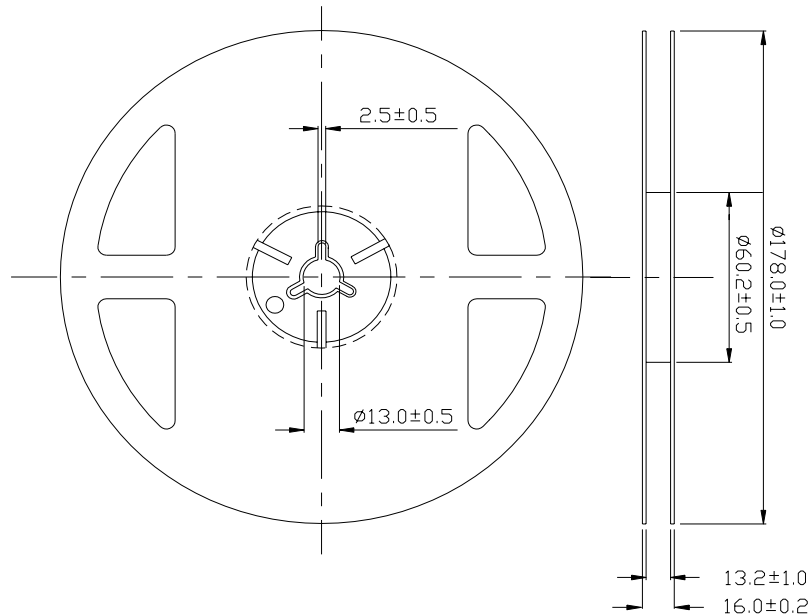

91-21SUGC/S400-XX/XXX

Loaded quantity per reel 1000 PCS/reel

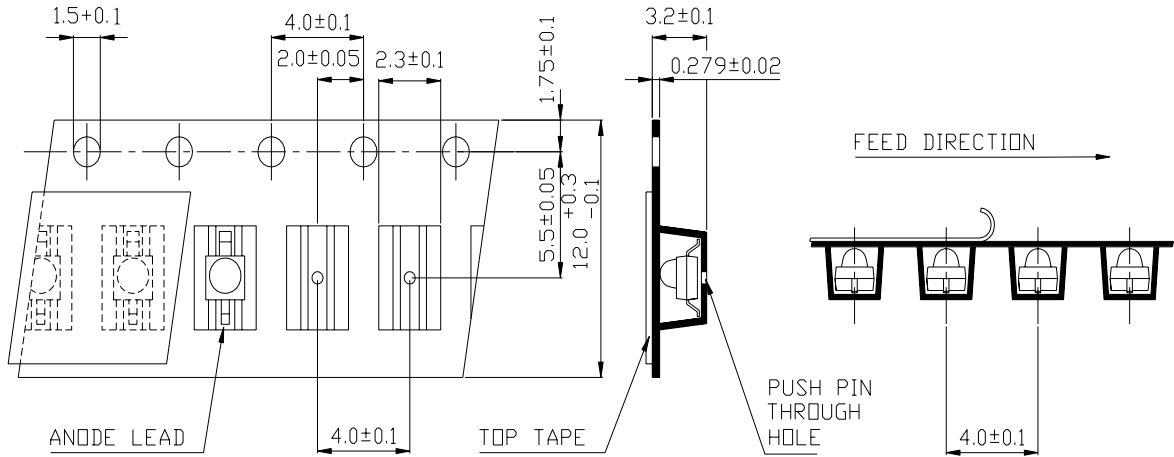

TR7

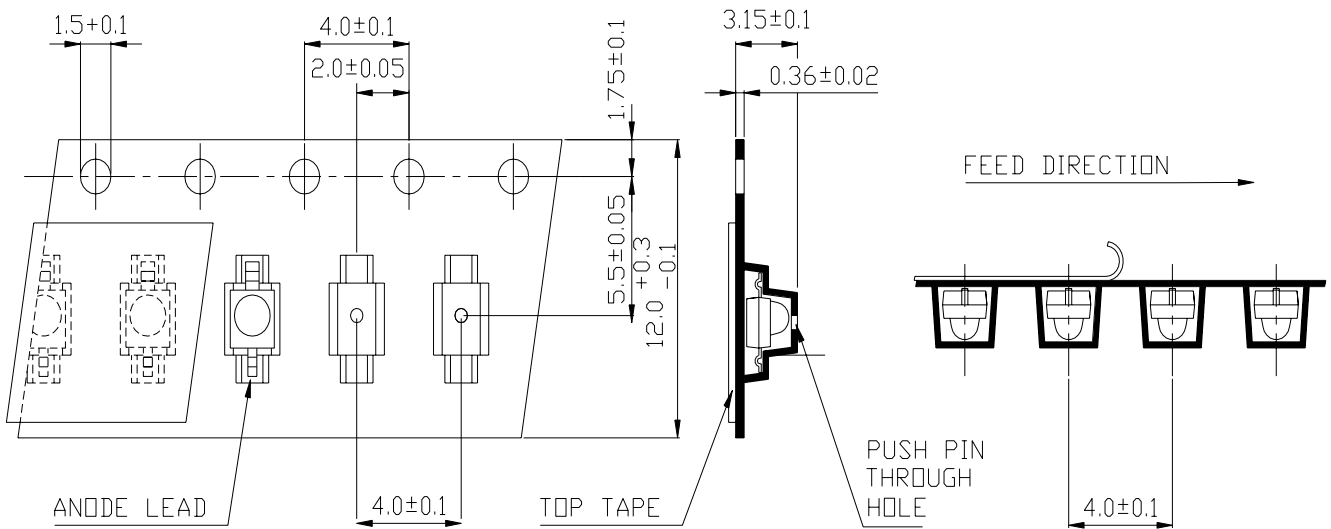

TR9

Loaded quantity per reel 1000 PCS/reel

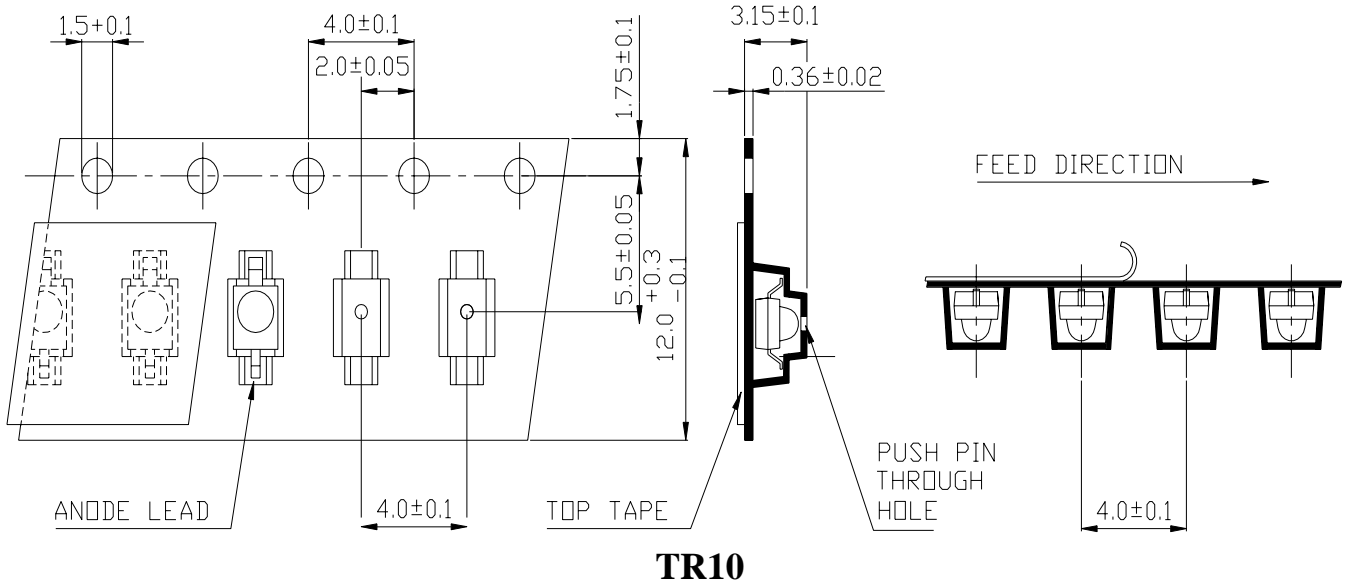

Unit :mm

Moisture Resistant Packaging

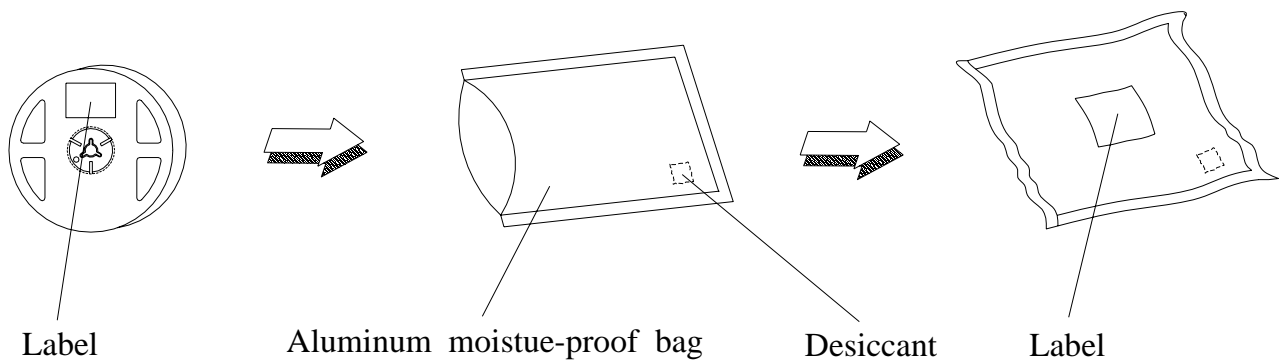

91-21SUGC/S400-XX/XXX**Reliability Test Items And Conditions**

The reliability of products shall be satisfied with items listed below.

Confidence level : 90 %

LTPD : 10 %

No.	Items	Test Condition	Test Hours/Cycles	Sample Size	Ac/Re
1	Reflow Soldering	Temp. : 260°C ±5°C Min. 5 sec.	6 Min.	22 Pcs.	0/1
2	Temperature Cycle	H : +100°C 15 min. § 5 min. L : -40°C 15 min.	300 Cycles	22 Pcs.	0/1
3	Thermal Shock	H : +100°C 5 min. § 10 sec. L : -10°C 5 min.	300 Cycles	22 Pcs.	0/1
4	High Temperature Storage	Temp. : 100°C	1000 Hrs.	22 Pcs.	0/1
5	Low Temperature Storage	Temp. : -40°C	1000 Hrs.	22 Pcs.	0/1
6	DC Operating Life	IF = 20 mA	1000 Hrs.	22 Pcs.	0/1
7	High Temperature / High Humidity	85°C/85%RH	1000 Hrs.	22 Pcs.	0/1

Precautions For Use

1. Over-current-proof

Customer must apply resistors for protection , otherwise slight voltage shift will cause big current change (Burn out will happen).

2. Storage

- 2.1 Do not open moisture proof bag before the products are ready to use.
- 2.2 Before opening the package, the LEDs should be kept at 30°C or less and 90%RH or less.
- 2.3 The LEDs should be used within a year.
- 2.4 After opening the package, the LEDs should be kept at 30°C or less and 70%RH or less.
- 2.5 The LEDs should be used within 168 hours (7 days) after opening the package.
- 2.6 If the moisture absorbent material (silica gel) has faded away or the LEDs have exceeded the storage time, baking treatment should be performed using the following conditions.
Baking treatment : 60±5°C for 24 hours.

3. Soldering Condition

3.1 Pb-free solder temperature profile

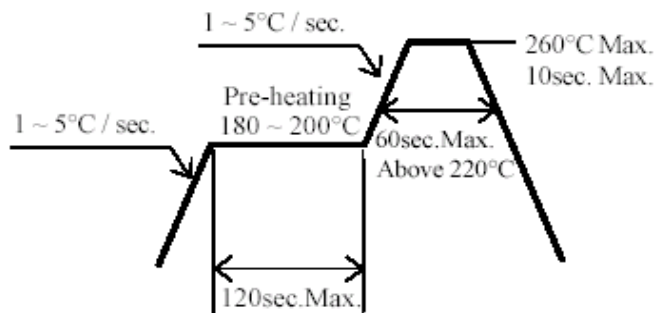

- 3.2 Reflow soldering should not be done more than two times.
- 3.3 When soldering, do not put stress on the LEDs during heating.
- 3.4 After soldering, do not warp the circuit board.

4. Soldering Iron

Each terminal is to go to the tip of soldering iron temperature less than 280°C for 3 seconds within once in less than the soldering iron capacity 25W. Leave two seconds and more intervals, and do soldering of each terminal. Be careful because the damage of the product is often started at the time of the hand solder.

5.Repairing

Repair should not be done after the LEDs have been soldered. When repairing is unavoidable, a double-head soldering iron should be used (as below figure). It should be confirmed beforehand whether the characteristics of the LEDs will or will not be damaged by repairing.

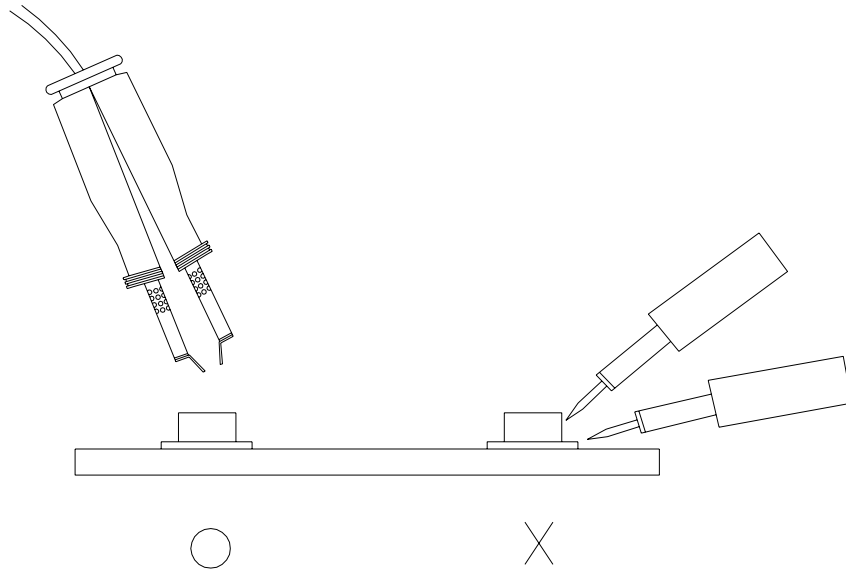

EVERLIGHT ELECTRONICS CO., LTD.
Office: No 25, Lane 76, Sec 3, Chung Yang Rd,
Tucheng, Taipei 236, Taiwan, R.O.C

Tel: 886-2-2267-2000, 2267-9936
Fax: 886-2267-6244, 2267-6189, 2267-6306
<http://www.everlight.com>