

## Technical Data Sheet

### 1.9mm Round Subminiature Lead LEDs

#### 95-21SUGC/S400-XX/XXX

#### Features

- Package in 12mm tape on 7" diameter reels.
- Compatible with automatic placement equipment.
- EIA Std. package.
- Mono-color type.
- Pb-free

#### Descriptions

- The 95-21 SMD LED is much smaller than leaded components . Thus enable smaller board size. Higher packing density. Reduced storage space and finally smaller equipment to be obtained.
- Besides, light weight makes them ideal for miniature applications.
- Furthermore by automation assembly machines the accuracy is anticipated.

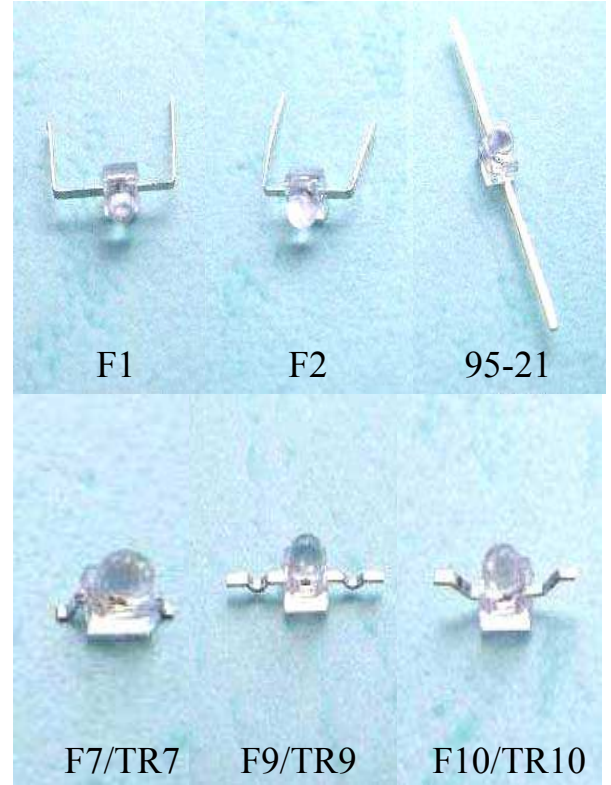

#### Applications

- Small indicator for indoor applications.
- Flat backlight for LCD, switches and symbols.
- Indicator and backlight in office equipment.
- Indicator and backlight for battery driven equipment.
- Indicator and backlight for audio and video equipment.
- Automotive : backlighting in dashboards and switches.
- Telecommunication : indicator and backlighting in telephone and fax.

#### Device Selection Guide

Part No.	Chip	Emitted Color	Resin Color
	Material		
95-21SUGC/S400-XX/XXX	InGaN	Super Green	Water Clear

**95-21SUGC/S400-XX/XXX**

**Package Outline Dimensions**

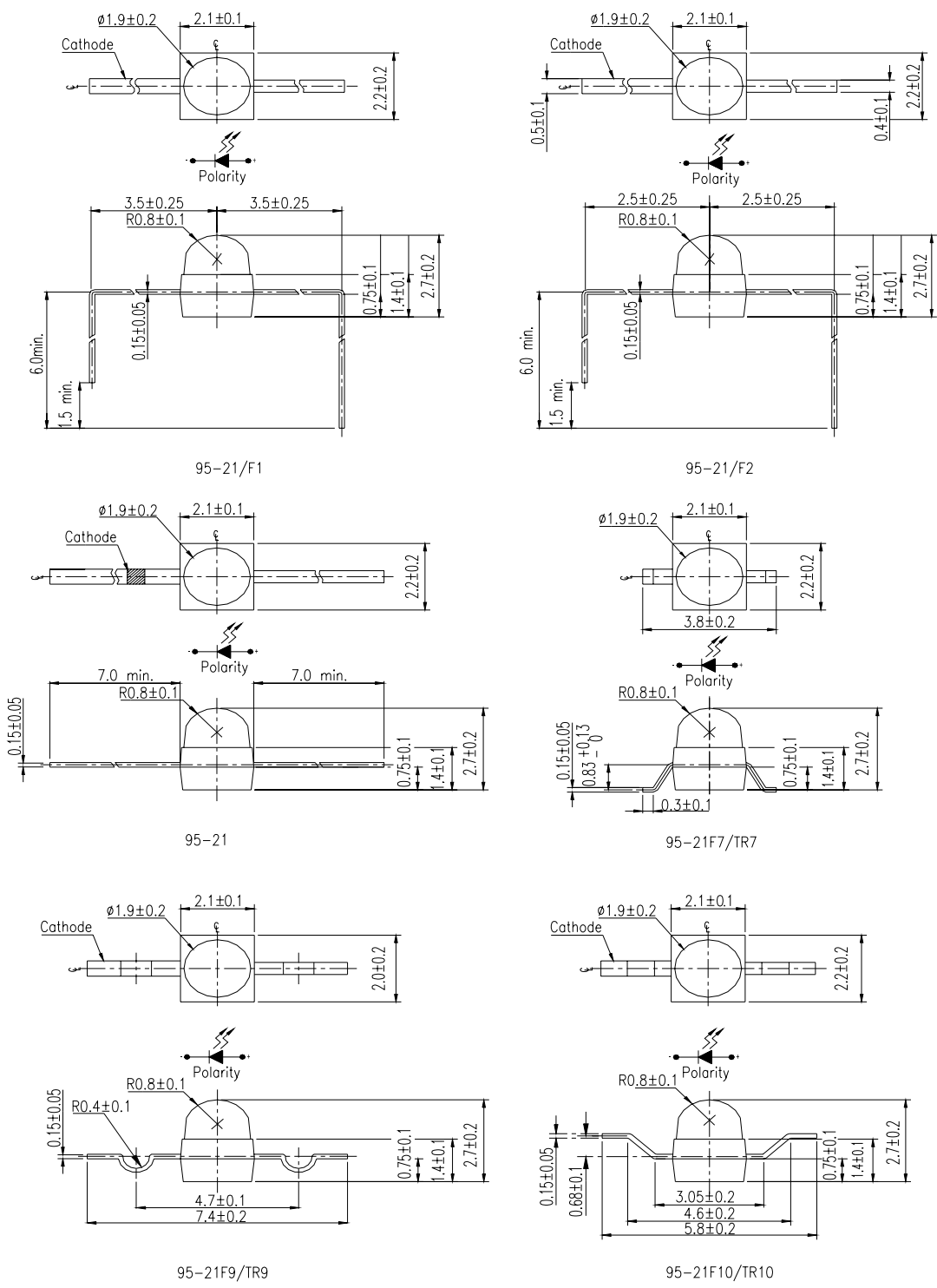

**Note:** The tolerances unless mentioned is  $\pm 0.1$ mm ,Unit = mm

**95-21SUGC/S400-XX/XXX**

**Absolute Maximum Ratings (Ta=25°C)**

Parameter	Symbol	Rating	Unit
Reverse Voltage	$V_R$	5	V
Forward Current	$I_F$	25	mA
Peak Forward Current (Duty 1/10 @1KHz)	$I_{FP}$	100	mA
Power Dissipation	$P_d$	110	mW
Electrostatic Discharge(HBM)	ESD	150	V
Operating Temperature	Topr	-40 ~ +85	°C
Storage Temperature	Tstg	-40 ~ +100	°C
Soldering Temperature	Tsol	Reflow Soldering : 260 °C for 10 sec. Hand Soldering : 350 °C for 3 sec.	

**95-21SUGC/S400-XX/XXX**

**Electro-Optical Characteristics (Ta=25°C)**

Parameter	Symbol	Chip Rank	MIN.	TYP.	MAX.	Unit	Condition
Luminous Intensity	Iv	A2	----	96	----	mcd	IF=2mA
			1000	1600	----		IF=20mA
		A4	----	160	----		IF=2mA
			2000	2300	----		IF=20mA
Viewing Angle	2θ 1/2	----	----	25	----	deg	IF=20mA
Peak Wavelength	λ p	----	----	518	----	nm	
Dominant Wavelength	λ d	----	----	525	----	nm	
Spectrum Radiation Bandwidth	△λ	----	----	35	----	nm	
Forward Voltage	VF	----	----	3.5	4.3	V	
Reverse Current	IR	----	----	----	50	μ A	VR=5V

\*95-21SUGC/S400- XX / XXX  
                                  1     2

1:Chip Rank

2:Packing Method:

(1) None,F1,F2, F7,F9,F10 : Bulk

(2) TR7,TR9,TR10 : Taping

**95-21SUGC/S400-XX/XXX**

**Typical Electro-Optical Characteristics Curves**

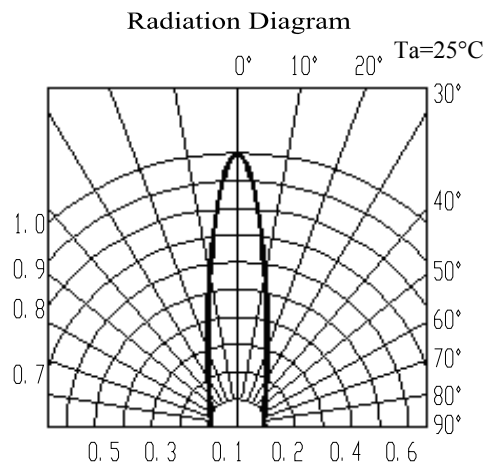
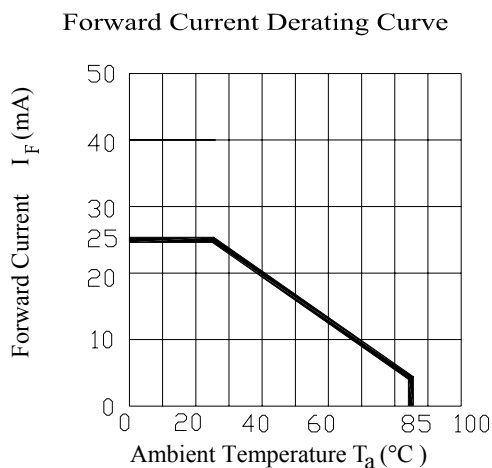
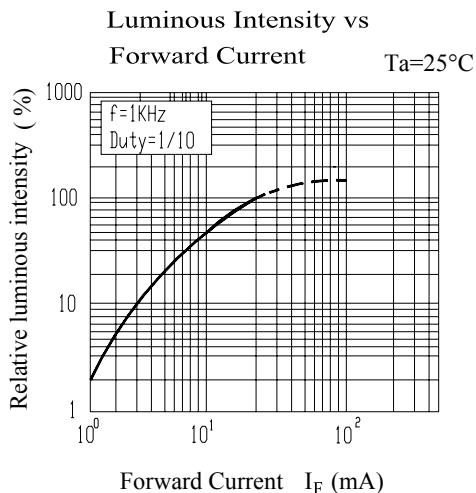
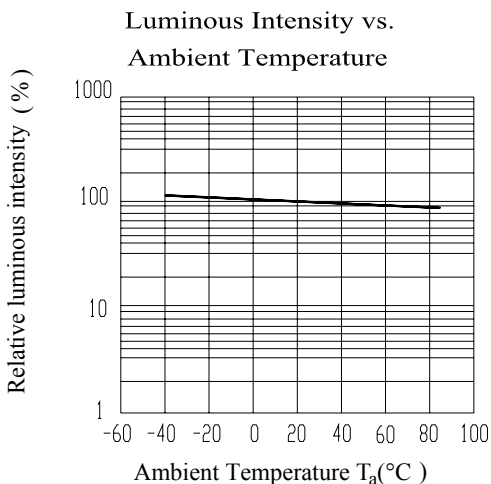
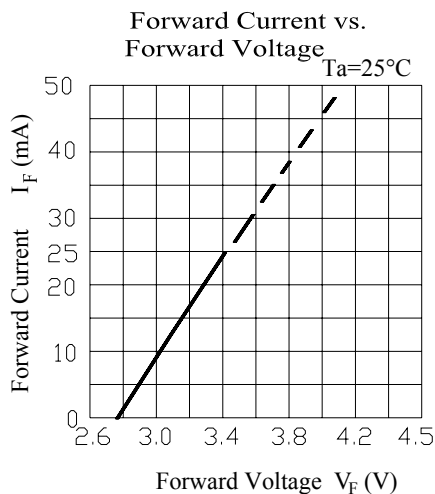
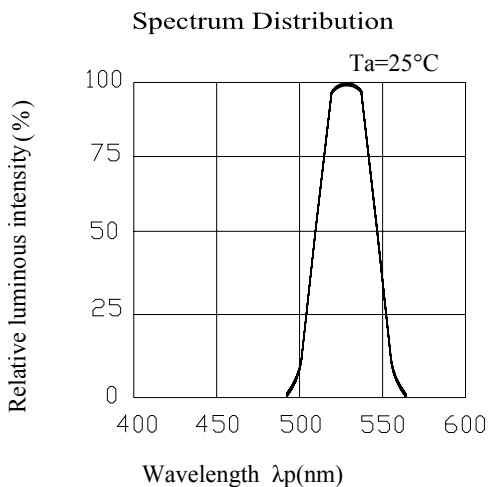

**95-21SUGC/S400-XX/XXX**

**Label explanation**

**CAT:** Luminous Intensity Rank

**HUE:** Dom. Wavelength Rank

**REF:** Forward Voltage Rank



**Reel & Carrier Tape Dimensions**

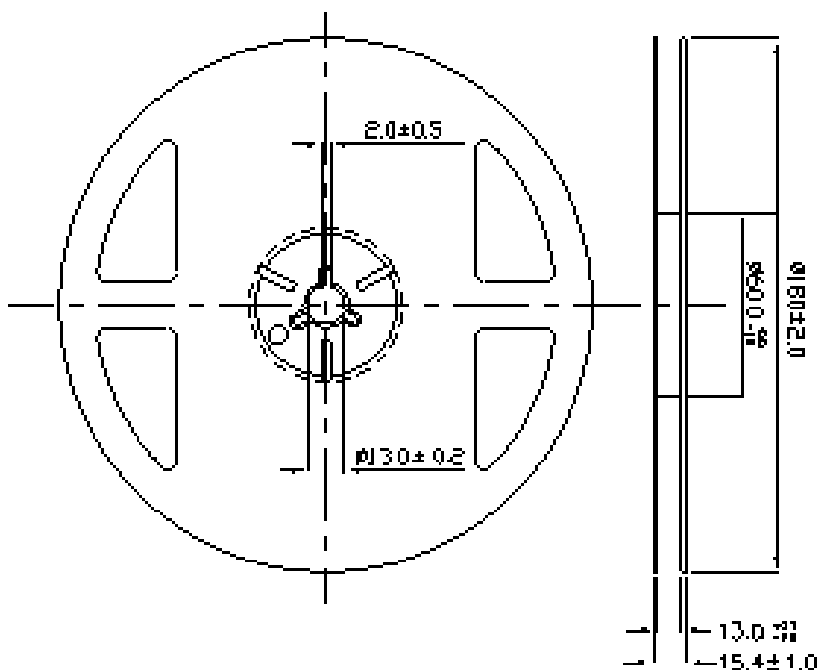

**Note:** The tolerances unless mentioned is  $\pm 0.1$ mm ,Unit = mm

**95-21SUGC/S400-XX/XXX**

**Carrier Tape Dimensions: Loaded quantity 1000 PCS per reel**

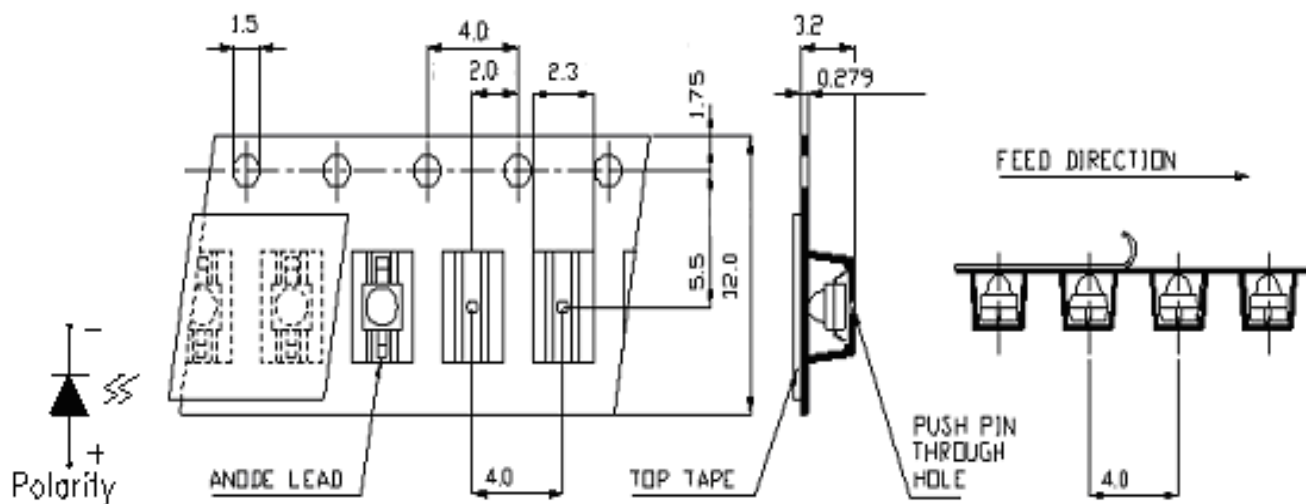

**TR7**

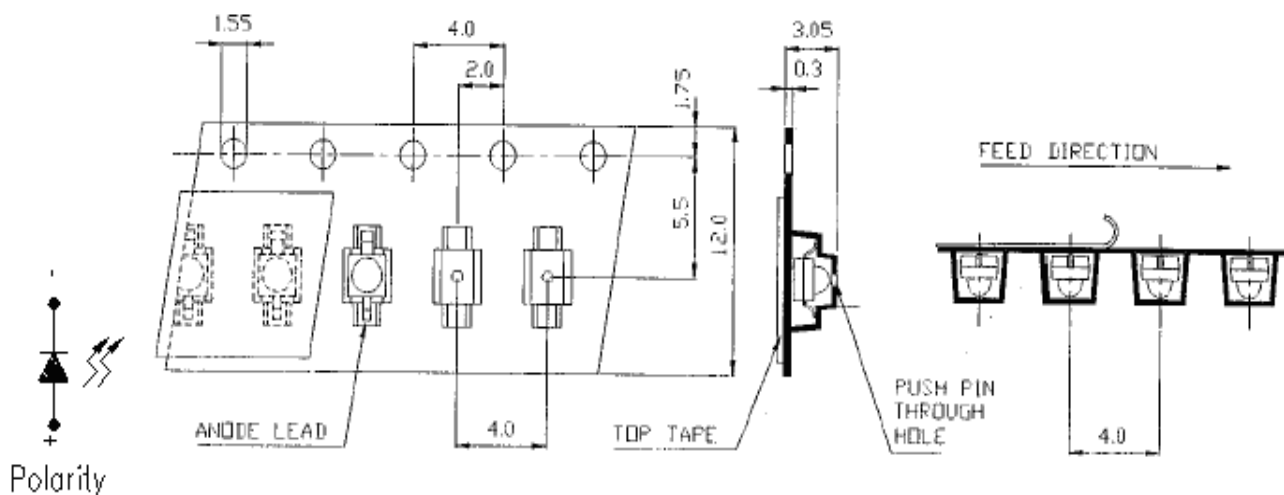

**TR10**

**95-21SUGC/S400-XX/XXX**

**Carrier Tape Dimensions: Loaded quantity 1000 PCS per reel**

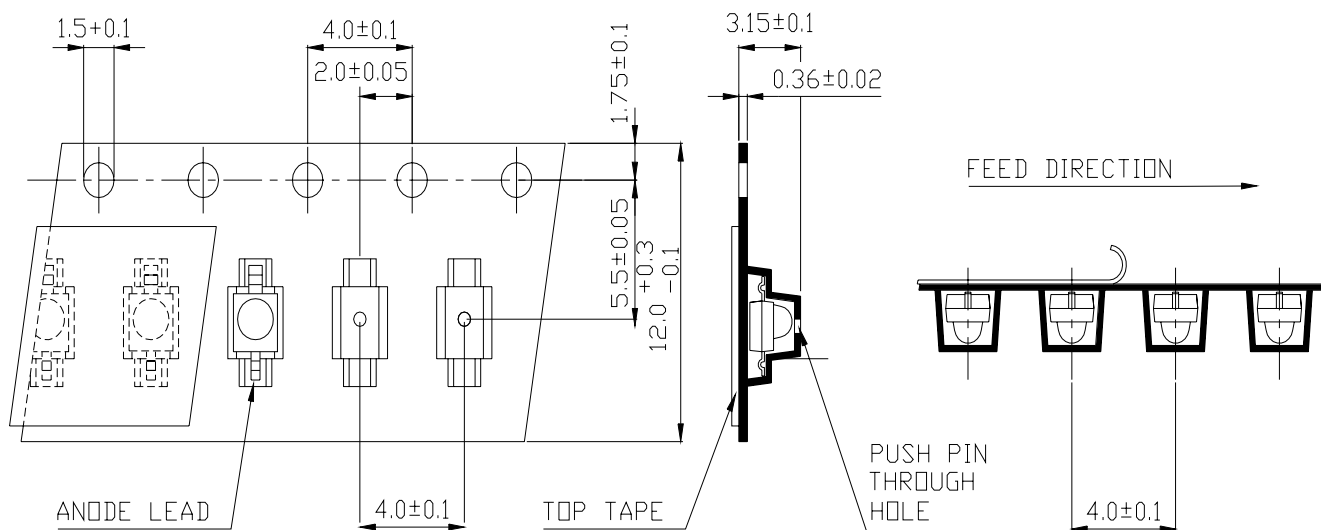

**TR9**

**Note:** The tolerances unless mentioned is  $\pm 0.1\text{mm}$ , Unit = mm

**Moisture Resistant Packaging**

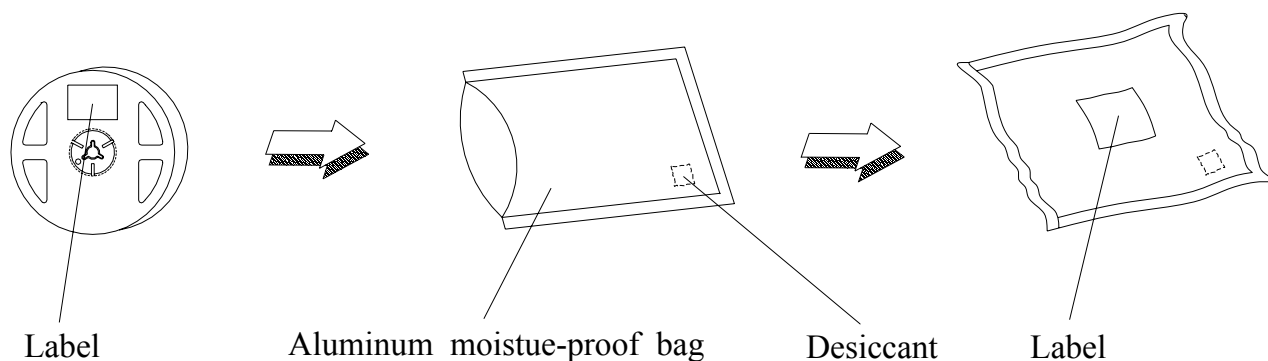



**95-21SUGC/S400-XX/XXX**

**Reliability Test Items And Conditions**

The reliability of products shall be satisfied with items listed below.

Confidence level : 90 %

LTPD : 10 %

No.	Items	Test Condition	Test Hours/Cycles	Sample Size	Ac/Re
1	Reflow Soldering	Temp. : 260°C ±5°C Min. 5 sec.	6 Min.	22 Pcs.	0/1
2	Temperature Cycle	H : +100°C 15 min. ∫ 5 min. L : -40°C 15 min.	300 Cycles	22 Pcs.	0/1
3	Thermal Shock	H : +100°C 5 min. ∫ 10 sec. L : -10°C 5 min.	300 Cycles	22 Pcs.	0/1
4	High Temperature Storage	Temp. : 100°C	1000 Hrs.	22 Pcs.	0/1
5	Low Temperature Storage	Temp. : -40°C	1000 Hrs.	22 Pcs.	0/1
6	DC Operating Life	IF = 20 mA	1000 Hrs.	22 Pcs.	0/1
7	High Temperature / High Humidity	85°C / 85% RH	1000 Hrs.	22 Pcs.	0/1

## Precautions For Use

### 1. Over-current-proof

Customer must apply resistors for protection , otherwise slight voltage shift will cause big current change ( Burn out will happen ).

### 2. Storage

2.1 Do not open moisture proof bag before the products are ready to use.

2.2 Before opening the package, the LEDs should be kept at 30°C or less and 90%RH or less.

2.3 After opening the package: The LED's floor life is 1 year under 30°C or less and 60% RH or less.

If unused LEDs remain, it should be stored in moisture proof packages.

2.4 If the moisture absorbent material (silica gel) has faded away or the LEDs have exceeded the storage time, baking treatment should be performed using the following conditions.

Baking treatment : 60±5°C for 24 hours.

### 3. Soldering Condition

#### 3.1 Pb-Free solder temperature profile

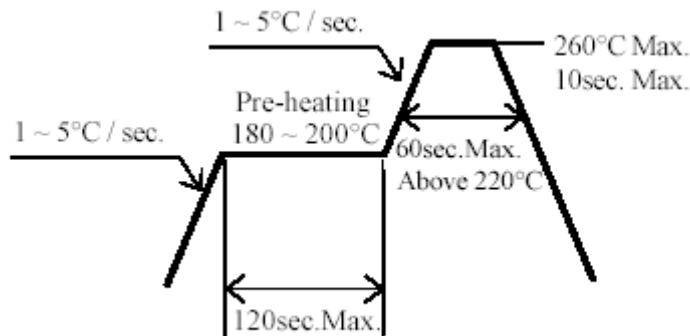

3.2 Reflow soldering should not be done more than two times.

3.3 When soldering, do not put stress on the LEDs during heating.

3.4 After soldering, do not warp the circuit board.

**95-21SUGC/S400-XX/XXX**

4. Soldering Iron

Each terminal is to go to the tip of soldering iron temperature less than 280°C for 3 seconds within once in less than the soldering iron capacity 25W. Leave two seconds and more intervals, and do soldering of each terminal. Be careful because the damage of the product is often started at the time of the hand solder.

5.Repairing

Repair should not be done after the LEDs have been soldered. When repairing is unavoidable, a double-head soldering iron should be used (as below figure). It should be confirmed beforehand whether the characteristics of the LEDs will or will not be damaged by repairing.

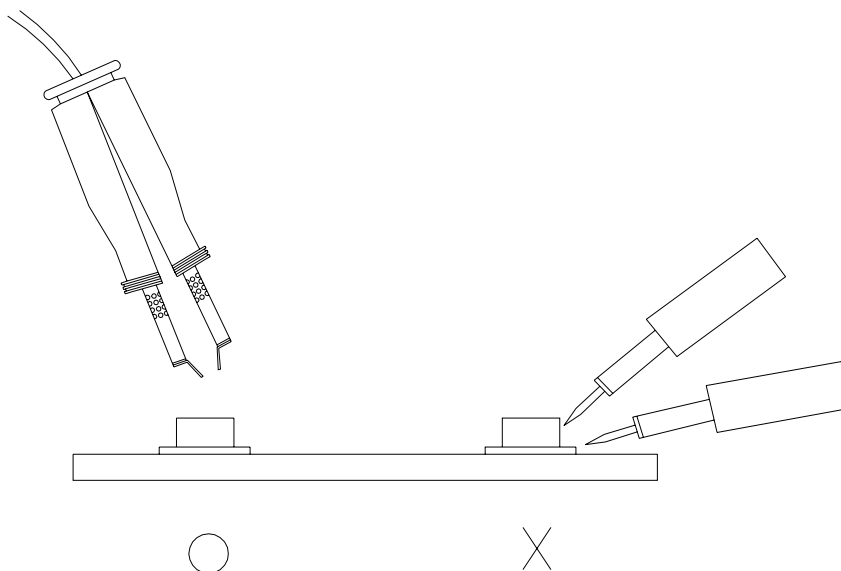

**EVERLIGHT ELECTRONICS CO., LTD.**  
Office: No 25, Lane 76, Sec 3, Chung Yang Rd,  
Tucheng, Taipei 236, Taiwan, R.O.C

Tel: 886-2-2267-2000, 2267-9936  
Fax: 886-2267-6244, 2267-6189, 2267-6306  
<http://www.everlight.com>