

Quad Monolithic SPST CMOS Analog Switches

DESCRIPTION

Featuring low on-resistance ($60\ \Omega$) and fast switching (130 ns), the DG308A is supplied in the “normally open” configuration while DG309 is supplied “normally closed”. Input thresholds are high voltage CMOS compatible.

Designed with the Vishay Siliconix PLUS-40 CMOS process to combine low power dissipation with a high breakdown voltage rating of 44 V, each switch conducts equally well in both directions when on, and blocks up to the supply voltage when off. An epitaxial layer prevents latch up.

The DG308B, DG309B upgrades are recommended for new designs.

FEATURES

- $\pm 15\text{ V}$ analog input range
- Low on-resistance: $60\ \Omega$
- Fast switching: 130 ns
- Low power dissipation: 30 nW
- CMOS logic compatible



RoHS*
COMPLIANT

BENEFITS

- Full rail-to-rail analog signal range
- Low signal error
- Wide dynamic range
- Single or dual supply capability
- Static protected logic inputs
- Space savings (TSSOP)

APPLICATIONS

- Portable and battery powered instrumentation
- Communication systems
- Computer peripherals
- High-speed multiplexing

FUNCTIONAL BLOCK DIAGRAM AND PIN CONFIGURATION

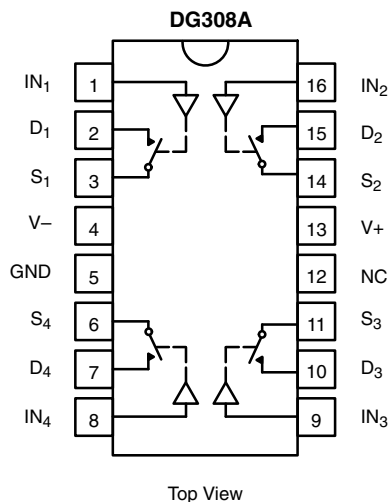

For SPST Switches per Package

TRUTH TABLE		
Logic	DG308A	DG309
0	OFF	ON
1	ON	OFF

Logic “0” $\leq 3.5\text{ V}$

Logic “1” $\geq 11\text{ V}$

* Pb containing terminations are not RoHS compliant, exemptions may apply



ORDERING INFORMATION		
Temp. Range	Package	Part Number
0 °C to 70 °C	16-Pin Plastic DIP	DG308ACJ DG308ACJ-E3
		DG309CJ DG309CJ-E3
- 40 °C to 85 °C	16-Pin Narrow SOIC	DG308ADY DG308ADY-E3 DG308ADY-T1 DG308ADY-T1-E3
		DG309DY DG309DY-E3 DG309DY-T1 DG309DY-T1-E3
		DG308ADQ DG308ADQ-E3 DG308ADQ-T1 DG308ADQ-T1-E3
	16-Pin TSSOP	DG309DQ DG309DQ-E3 DG309DQ-T1 DG309DQ-T1-E3

ABSOLUTE MAXIMUM RATINGS			
Parameter	Limit	Unit	
Voltages Referenced V+ to V-	44	V	
GND	25		
Digital Inputs ^a , V _S , V _D	(V-) - 2 to (V+) + 2 or 20 mA, whichever occurs first		
Current, Any Terminal Except S or D	30	mA	
Continuous Current	S or D		20
	(Pulsed at 1 ms, 10 % duty cycle max.)		70
Storage Temperature	(AK Suffix)	- 65 to 150	°C
	(CJ, DY and DQ Suffix)	- 65 to 125	
Power Dissipation ^b	16-Pin Plastic DIP ^c	470	mW
	16-Pin Narrow SOIC and TSSOP ^e	600	
	16-Pin CerDIP ^d	900	

Notes:

- a. Signals on S_X, D_X, or IN_X exceeding V+ or V- will be clamped by internal diodes. Limit forward diode current to maximum current ratings.
- b. All leads welded or soldered to PC board.
- c. Derate 12 mW/°C above 75 °C.
- d. Derate 6.5 mW/°C above 25 °C.
- e. Derate 7.6 mW/°C above 75 °C.

SCHEMATIC DIAGRAM (Typical Channel)

Figure 1.

SPECIFICATIONS ^a									
Parameter	Symbol	Test Conditions Unless Specified $V_+ = 15\text{ V}$, $V_- = -15\text{ V}$ $V_{IN} = 3.5\text{ V}$ or 11 V ^f	Temp. ^b	Typ. ^c	A Suffix -55 °C to 125 °C		C, D Suffix		Unit
					Min. ^d	Max. ^d	Min. ^d	Max. ^d	
Analog Switch									
Analog Signal Range ^e	V_{ANALOG}		Full		-15	15	-15	15	V
Drain-Source On-Resistance	$R_{DS(on)}$	$V_D = \pm 10\text{ V}$, $I_S = 1\text{ mA}$	Room Full	60		100 150		100 125	Ω
Source Off Leakage Current	$I_{S(off)}$	$V_S = \pm 14\text{ V}$, $V_D = \pm 14\text{ V}$	Room Full	± 0.1	-1 100	1 100	-5 -100	5 100	nA
Drain Off Leakage Current	$I_{D(off)}$	$V_D = \pm 14\text{ V}$, $V_S = \pm 14\text{ V}$	Room Full	± 0.1	-1 100	1 100	-5 -100	5 100	
Drain On Leakage Current	$I_{D(on)}$	$V_D = V_S = \pm 14\text{ V}$	Room Full	± 0.1	-1 100	1 100	-5 -200	5 200	
Digital Control									
Input Current with Input Voltage High	I_{INH}	$V_{IN} = 15\text{ V}$	Full	0.001		1		1	μA
Input Current with Input Voltage Low	I_{INL}	$V_{IN} = 0\text{ V}$	Full	-0.001	-1		-1		
Input Capacitance	C_{IN}		Room	8					pF
Dynamic Characteristics									
Turn-On Time	t_{ON}	see figure 2	Room	130		200		200	ns
Turn-Off Time	t_{OFF}		Room	90		150		150	
Charge Injection	Q	$C_L = 0.01\ \mu\text{F}$, $R_{gen} = 0\ \Omega$, $V_{gen} = 0\text{ V}$,	Room	-10					pC
Source-Off Capacitance	$C_{S(off)}$	$f = 140\text{ kHz}$, V_S , $V_D = 0\text{ V}$	Room	11					pF
Drain-Off Capacitance	$C_{D(off)}$		Room	8					
Channel-On Capacitance	$C_{D(on)}$		Room	27					
Off-Isolation ^f	OIRR	$R_L = 75\ \Omega$, $V_S = 2\text{ V}_{p-p}$, $f = 500\text{ kHz}$	Room	78					dB

SPECIFICATIONS^a

Parameter	Symbol	Test Conditions Unless Specified $V_+ = 15\text{ V}$, $V_- = -15\text{ V}$ $V_{IN} = 3.5\text{ V}$ or 11 V ^f	Temp. ^b	Typ. ^c	A Suffix -55 °C to 125 °C		C, D Suffix		Unit
					Min. ^d	Max. ^d	Min. ^d	Max. ^d	
Power Supplies									
Positive Supply Current	I+	all channels on or off $V_{IN} = 0\text{ V}$ or 15 V	Room Full	0.001		10	10	100	μA
Negative Supply Current	I-		Room Full	-0.001	-10 -100		-100		

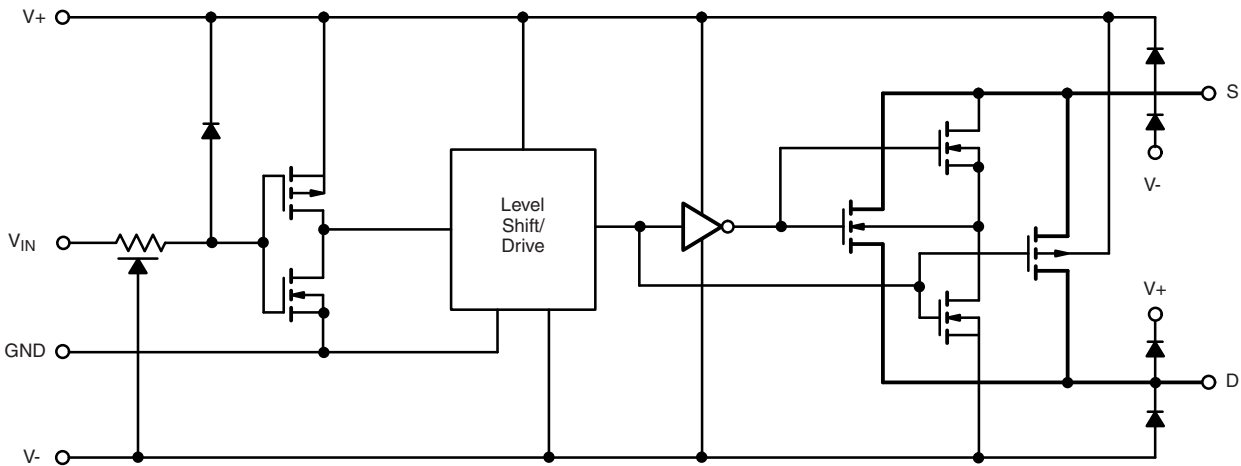
Notes:

a. Refer to PROCESS OPTION FLOWCHART.

b. Room = 25 °C, Full = as determined by the operating temperature suffix.

c. Typical values are for DESIGN AID ONLY, not guaranteed nor subject to production testing.

d. The algebraic convention whereby the most negative value is a minimum and the most positive a maximum, is used in this data sheet.

e. Guaranteed by design, not subject to production test.

f. V_{IN} = input voltage to perform proper function.

Stresses beyond those listed under "Absolute Maximum Ratings" may cause permanent damage to the device. These are stress ratings only, and functional operation of the device at these or any other conditions beyond those indicated in the operational sections of the specifications is not implied. Exposure to absolute maximum rating conditions for extended periods may affect device reliability.

TYPICAL CHARACTERISTICS (25 °C, unless otherwise noted)

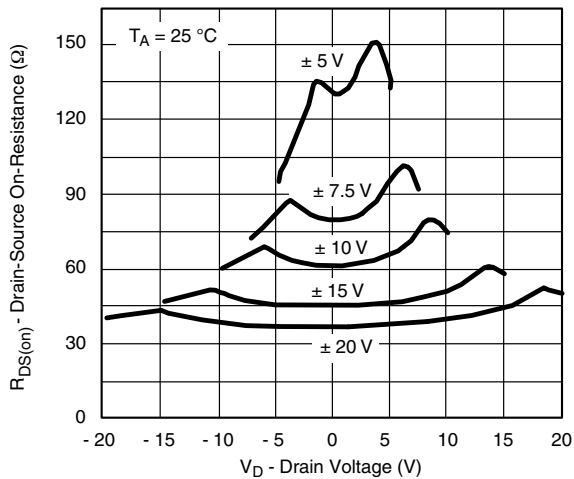

$R_{DS(on)}$ vs. V_D and Power Supply

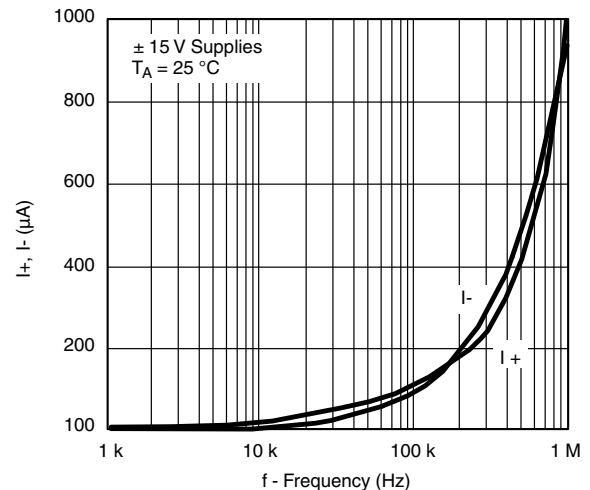

Supply Currents vs. Switching Frequency (All Inputs Active)

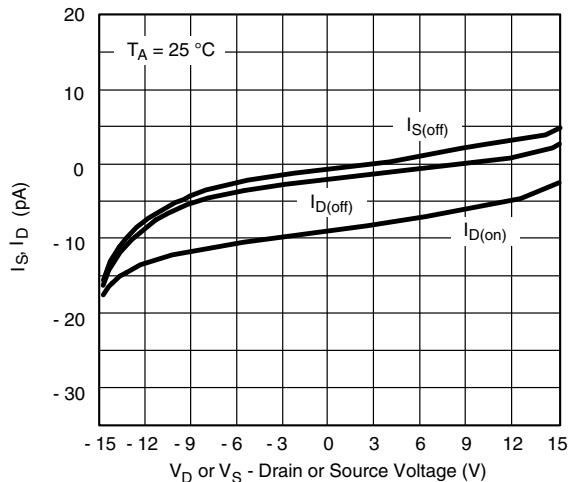

Leakage Currents vs. Analog Voltage

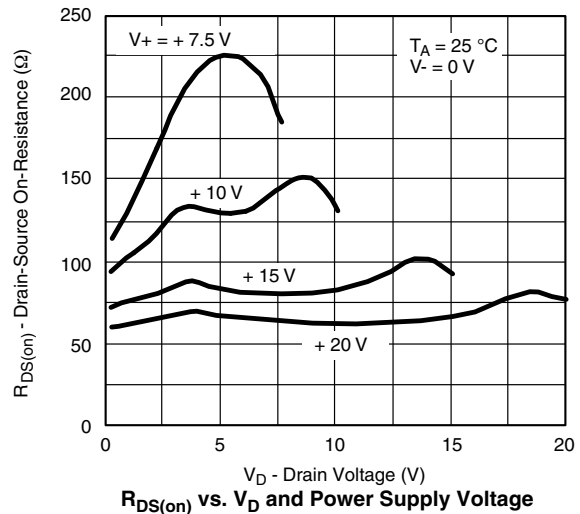

$R_{DS(on)}$ vs. V_D and Power Supply Voltage

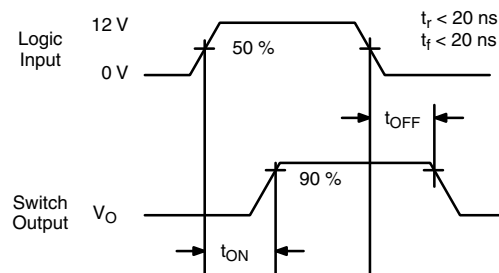
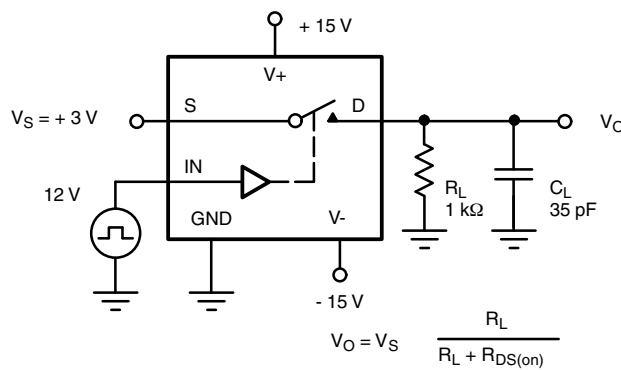
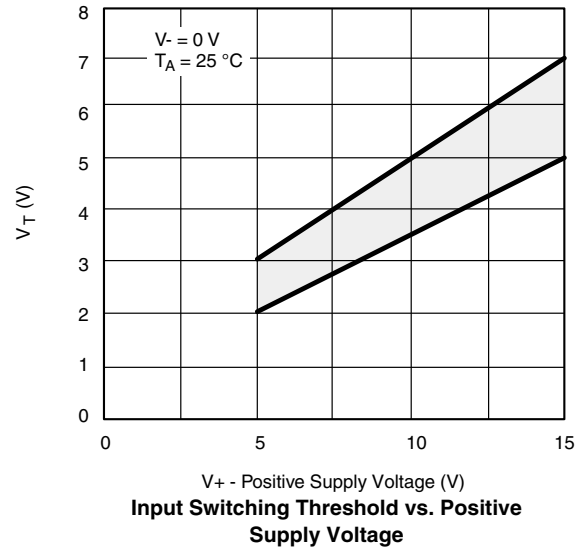
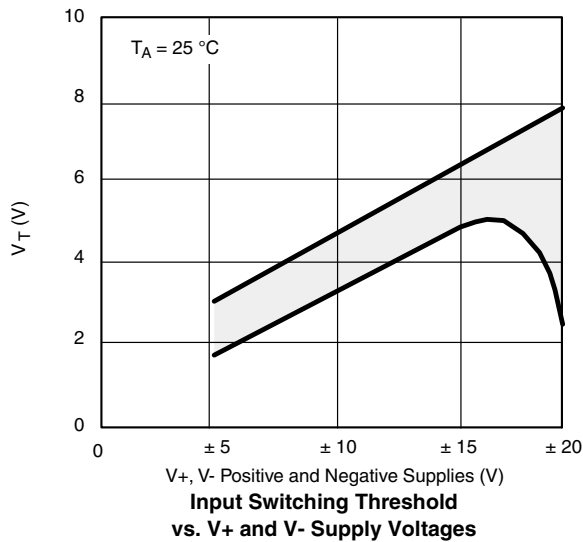
TYPICAL CHARACTERISTICS (25 °C, unless otherwise noted)

Figure 2. Switching Time
APPLICATIONS
Single Supply Operation

The DG308A and DG309 will switch positive analog signals while using a single positive supply. This will allow use in many applications where only one supply is available. The trade-offs or performance given up while using single supplies are:

1) increased $R_{DS(on)}$ and 2) slower switching speed. As stated in the absolute maximum ratings section of the data sheet, the analog voltage should not go above or below the supply voltages which in single supply operation are $V+$ and 0 V.

Vishay Siliconix maintains worldwide manufacturing capability. Products may be manufactured at one of several qualified locations. Reliability data for Silicon Technology and Package Reliability represent a composite of all qualified locations. For related documents such as package/tape drawings, part marking, and reliability data, see www.vishay.com/ppg?70046.



SOIC (NARROW): 16-LEAD
JEDEC Part Number: MS-012

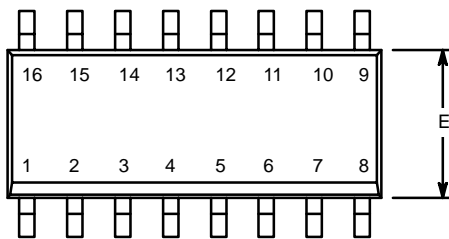

Dim	MILLIMETERS		INCHES	
	Min	Max	Min	Max
A	1.35	1.75	0.053	0.069
A ₁	0.10	0.20	0.004	0.008
B	0.38	0.51	0.015	0.020
C	0.18	0.23	0.007	0.009
D	9.80	10.00	0.385	0.393
E	3.80	4.00	0.149	0.157
e	1.27 BSC		0.050 BSC	
H	5.80	6.20	0.228	0.244
L	0.50	0.93	0.020	0.037
∅	0°	8°	0°	8°

ECN: S-03946—Rev. F, 09-Jul-01
DWG: 5300

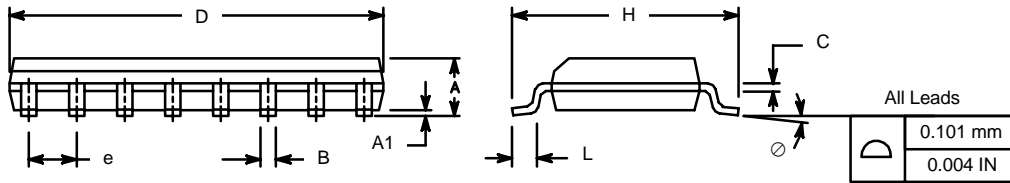

PDIP: 16-LEAD

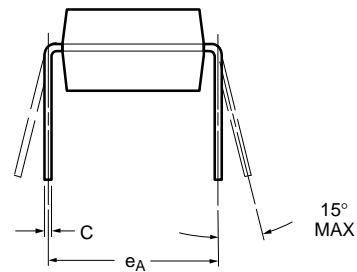
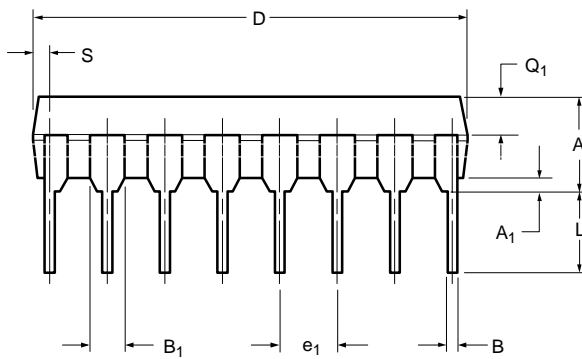
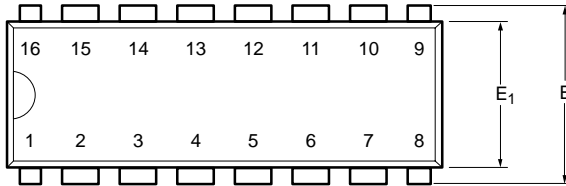

Dim	MILLIMETERS		INCHES	
	Min	Max	Min	Max
A	3.81	5.08	0.150	0.200
A₁	0.38	1.27	0.015	0.050
B	0.38	0.51	0.015	0.020
B₁	0.89	1.65	0.035	0.065
C	0.20	0.30	0.008	0.012
D	18.93	21.33	0.745	0.840
E	7.62	8.26	0.300	0.325
E₁	5.59	7.11	0.220	0.280
e₁	2.29	2.79	0.090	0.110
e_A	7.37	7.87	0.290	0.310
L	2.79	3.81	0.110	0.150
Q₁	1.27	2.03	0.050	0.080
S	0.38	1.52	.015	0.060

ECN: S-03946—Rev. D, 09-Jul-01
DWG: 5482

CERDIP: 16-LEAD

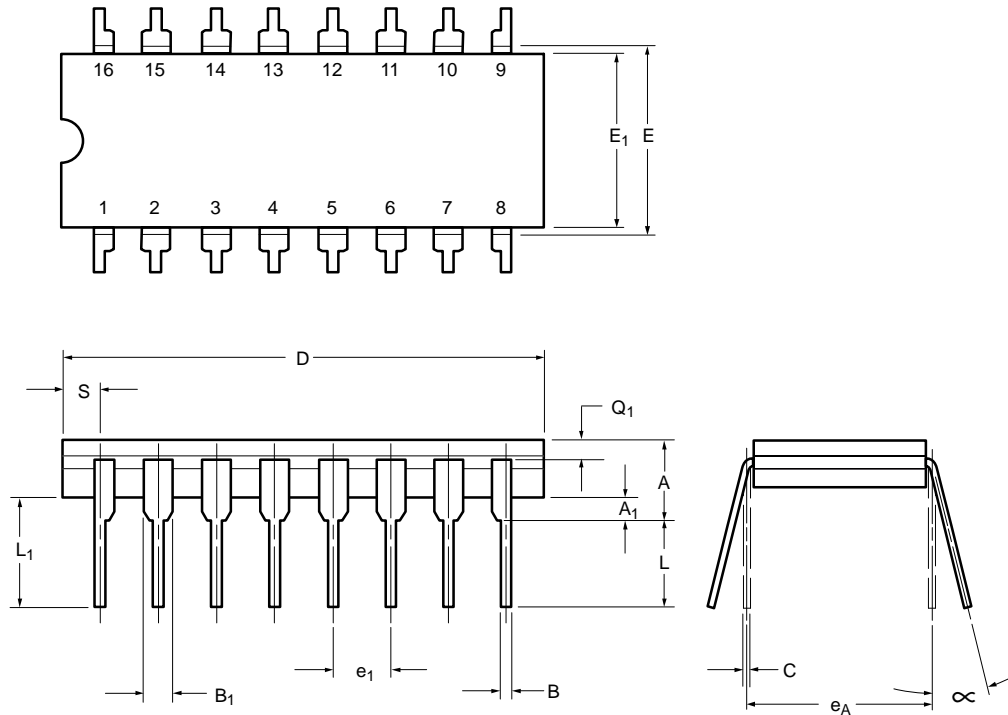

Dim	MILLIMETERS		INCHES	
	Min	Max	Min	Max
A	4.06	5.08	0.160	0.200
A ₁	0.51	1.14	0.020	0.045
B	0.38	0.51	0.015	0.020
B ₁	1.14	1.65	0.045	0.065
C	0.20	0.30	0.008	0.012
D	19.05	19.56	0.750	0.770
E	7.62	8.26	0.300	0.325
E ₁	6.60	7.62	0.260	0.300
e ₁	2.54 BSC		0.100 BSC	
e _A	7.62 BSC		0.300 BSC	
L	3.18	3.81	0.125	0.150
L ₁	3.81	5.08	0.150	0.200
Q ₁	1.27	2.16	0.050	0.085
S	0.38	1.14	0.015	0.045
∞	0°	15°	0°	15°

ECN: S-03946—Rev. G, 09-Jul-01
DWG: 5403

TSSOP: 16-LEAD

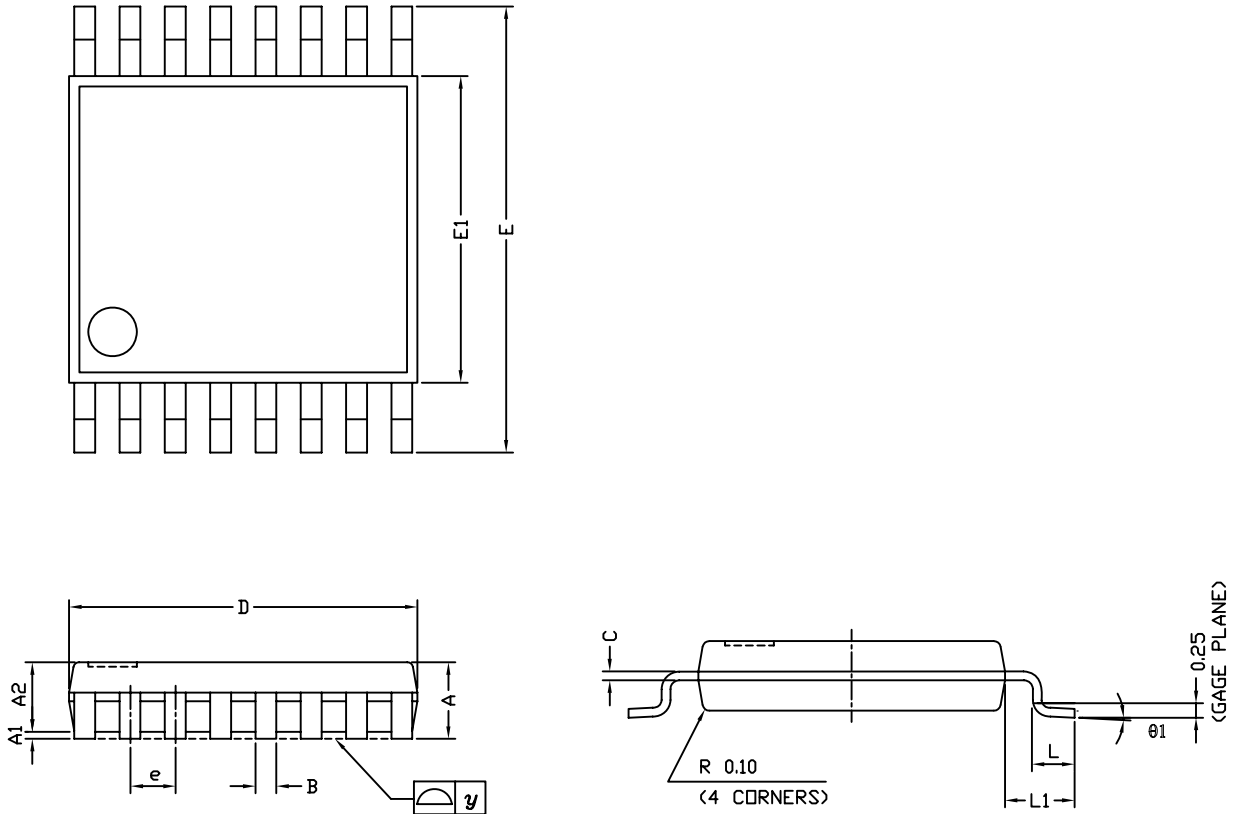

Symbols	DIMENSIONS IN MILLIMETERS		
	Min	Nom	Max
A	-	1.10	1.20
A1	0.05	0.10	0.15
A2	-	1.00	1.05
B	0.22	0.28	0.38
C	-	0.127	-
D	4.90	5.00	5.10
E	6.10	6.40	6.70
E1	4.30	4.40	4.50
e	-	0.65	-
L	0.50	0.60	0.70
L1	0.90	1.00	1.10
y	-	-	0.10
θ1	0°	3°	6°

ECN: S-61920-Rev. D, 23-Oct-06
DWG: 5624



RECOMMENDED MINIMUM PAD FOR TSSOP-16

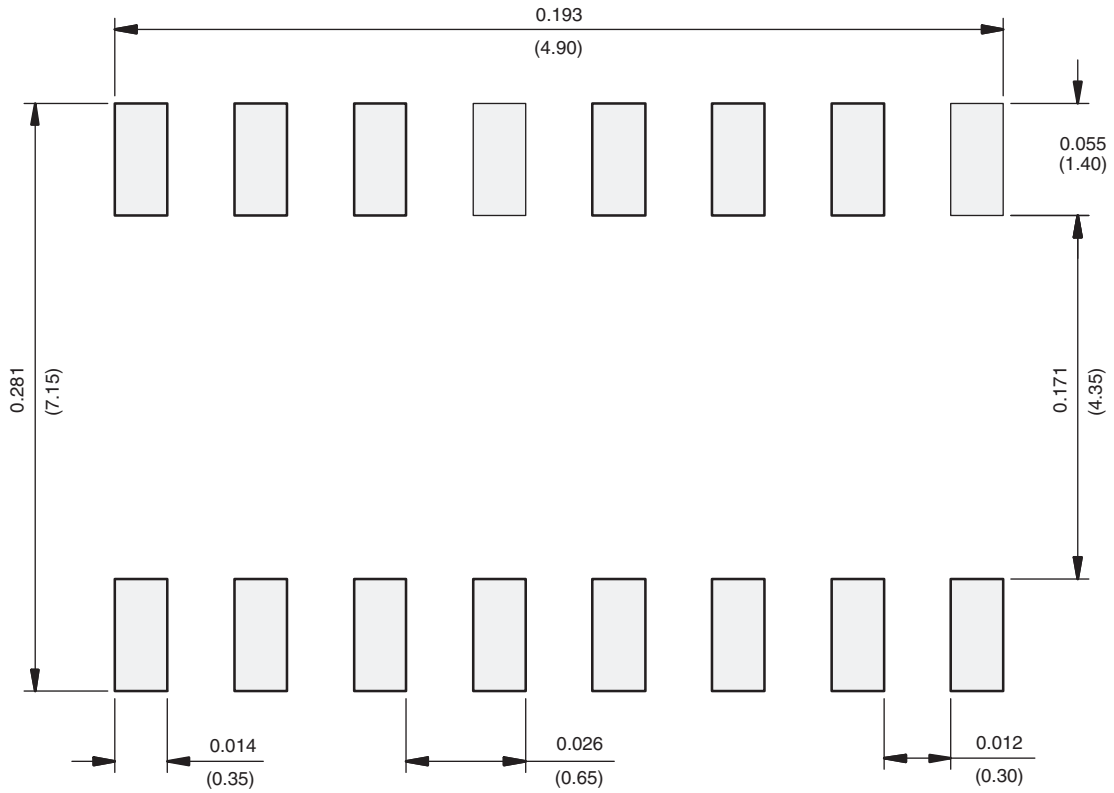

Recommended Minimum Pads
Dimensions in inches (mm)

RECOMMENDED MINIMUM PADS FOR SO-16

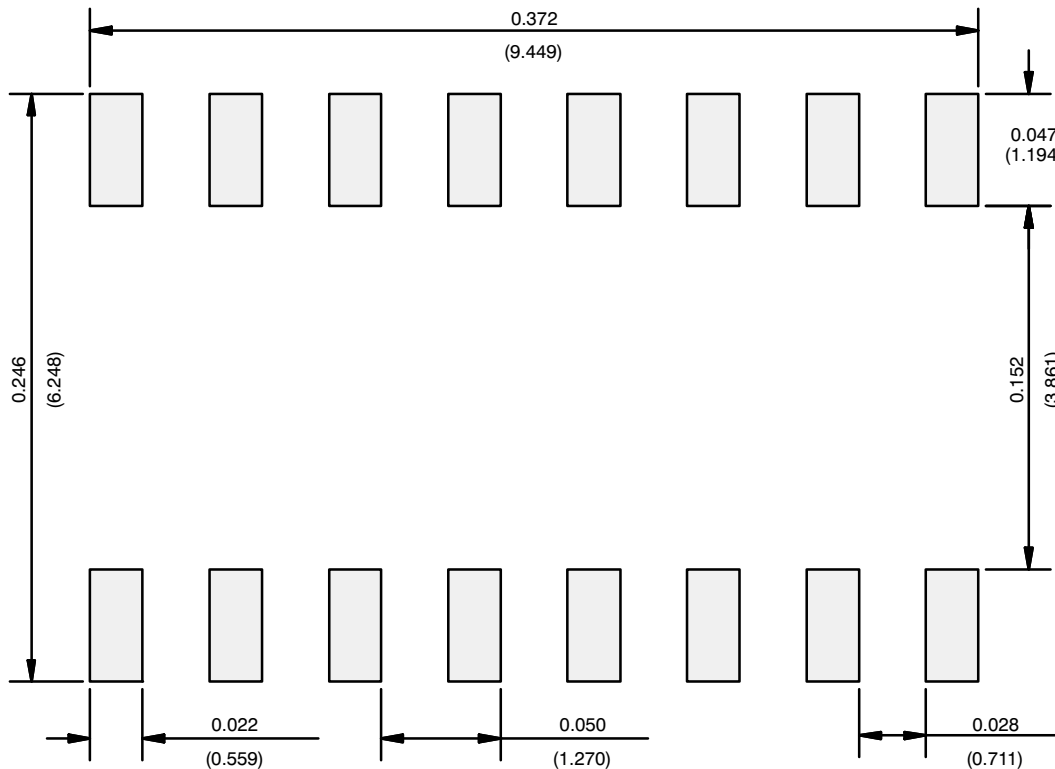

Recommended Minimum Pads
Dimensions in Inches/(mm)

[Return to Index](#)



Disclaimer

ALL PRODUCT, PRODUCT SPECIFICATIONS AND DATA ARE SUBJECT TO CHANGE WITHOUT NOTICE TO IMPROVE RELIABILITY, FUNCTION OR DESIGN OR OTHERWISE.

Vishay Intertechnology, Inc., its affiliates, agents, and employees, and all persons acting on its or their behalf (collectively, "Vishay"), disclaim any and all liability for any errors, inaccuracies or incompleteness contained in any datasheet or in any other disclosure relating to any product.

Vishay makes no warranty, representation or guarantee regarding the suitability of the products for any particular purpose or the continuing production of any product. To the maximum extent permitted by applicable law, Vishay disclaims (i) any and all liability arising out of the application or use of any product, (ii) any and all liability, including without limitation special, consequential or incidental damages, and (iii) any and all implied warranties, including warranties of fitness for particular purpose, non-infringement and merchantability.

Statements regarding the suitability of products for certain types of applications are based on Vishay's knowledge of typical requirements that are often placed on Vishay products in generic applications. Such statements are not binding statements about the suitability of products for a particular application. It is the customer's responsibility to validate that a particular product with the properties described in the product specification is suitable for use in a particular application. Parameters provided in datasheets and/or specifications may vary in different applications and performance may vary over time. All operating parameters, including typical parameters, must be validated for each customer application by the customer's technical experts. Product specifications do not expand or otherwise modify Vishay's terms and conditions of purchase, including but not limited to the warranty expressed therein.

Except as expressly indicated in writing, Vishay products are not designed for use in medical, life-saving, or life-sustaining applications or for any other application in which the failure of the Vishay product could result in personal injury or death. Customers using or selling Vishay products not expressly indicated for use in such applications do so at their own risk and agree to fully indemnify and hold Vishay and its distributors harmless from and against any and all claims, liabilities, expenses and damages arising or resulting in connection with such use or sale, including attorneys fees, even if such claim alleges that Vishay or its distributor was negligent regarding the design or manufacture of the part. Please contact authorized Vishay personnel to obtain written terms and conditions regarding products designed for such applications.

No license, express or implied, by estoppel or otherwise, to any intellectual property rights is granted by this document or by any conduct of Vishay. Product names and markings noted herein may be trademarks of their respective owners.

Material Category Policy

Vishay Intertechnology, Inc. hereby certifies that all its products that are identified as RoHS-Compliant fulfill the definitions and restrictions defined under Directive 2011/65/EU of The European Parliament and of the Council of June 8, 2011 on the restriction of the use of certain hazardous substances in electrical and electronic equipment (EEE) - recast, unless otherwise specified as non-compliant.

Please note that some Vishay documentation may still make reference to RoHS Directive 2002/95/EC. We confirm that all the products identified as being compliant to Directive 2002/95/EC conform to Directive 2011/65/EU.