

Improved Quad SPST CMOS Analog Switches

DESCRIPTION

The DG441B, DG442B are monolithic quad analog switches designed to provide high speed, low error switching of analog and audio signals. The DG441B, DG442B are upgrades to the original DG441, DG442.

Combining low on-resistance (45 Ω , typ.) with high speed (t_{ON} 120 ns, typ.), the DG441B, DG442B are ideally suited for Data Acquisition, Communication Systems, Automatic Test Equipment, or Medical Instrumentation. Charge injection has been minimized on the drain for use in sample-and-hold circuits.

The DG441B, DG442B are built using Vishay Siliconix's high-voltage silicon-gate process. An epitaxial layer prevents latchup.

When on, each switch conducts equally well in both directions and blocks input voltages to the supply levels when off.

FEATURES

- Halogen-free according to IEC 61249-2-21 Definition
- Low On-Resistance: 45 Ω
- Low Power Consumption: 1 mW
- Fast Switching Action - t_{ON} : 120 ns
- Low Charge Injection - Q: - 1 pC
- TTL/CMOS-Compatible Logic
- Single Supply Capability
- Compliant to RoHS Directive 2002/95/EC



RoHS
COMPLIANT
HALOGEN
FREE

BENEFITS

- Less Signal Errors and Distortion
- Reduced Power Supply Requirements
- Faster Throughput
- Reduced Pedestal Errors
- Simple Interfacing

APPLICATIONS

- Audio Switching
- Data Acquisition
- Sample-and-Hold Circuits
- Communication Systems
- Automatic Test Equipment
- Medical Instruments

FUNCTIONAL BLOCK DIAGRAM AND PIN CONFIGURATION

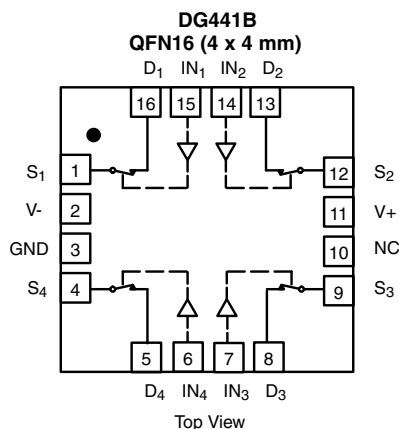
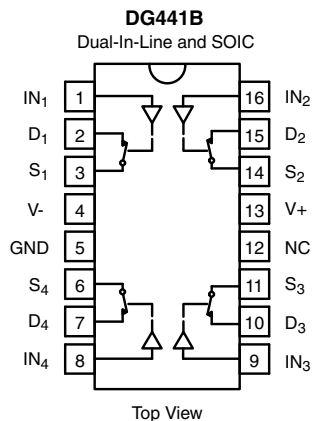

TRUTH TABLE		
Logic	DG441B	DG442B
0	ON	OFF
1	OFF	ON

Logic "0" ≤ 0.8 V
Logic "1" ≥ 2.4 V

ORDERING INFORMATION		
Temp Range	Package	Part Number
- 40 °C to 85 °C	16-pin Plastic DIP	DG441BDJ
		DG441BDJ-E3
		DG442BDJ
	16-pin Narrow SOIC	DG442BDJ-E3
		DG441BDY-E3
		DG441BDY-T1-E3
		DG442BDY-E3
	16 pin QFN 4 x 4 mm	DG442BDY-T1-E3
		DG441BDN-T1-E4

ABSOLUTE MAXIMUM RATINGS ($T_A = 25\text{ }^\circ\text{C}$, unless otherwise noted)			
Parameter	Symbol	Limit	Unit
V+ to V-		44	V
GND to V-		25	
Digital Inputs ^a , V_S , V_D		(V-) - 2 to (V+) + 2 or 30 mA, whichever occurs first	
Continuous Current (Any Terminal)		30	mA
Current, S or D (Pulsed at 1 ms, 10 % duty cycle)		100	
Storage Temperature		- 65 to 125	$^\circ\text{C}$
Power Dissipation (Package) ^b	16-pin Plastic DIP ^c	470	mW
	16-pin Narrow Body SOIC ^d	900	
	QFN-16 ^d	850	

Notes:

- Signals on S_X , D_X , or IN_X exceeding V+ or V- will be clamped by internal diodes. Limit forward diode current to maximum current ratings.
- All leads welded or soldered to PC Board.
- Derate 6 mW/ $^\circ\text{C}$ above 75 $^\circ\text{C}$.
- Derate 12 mW/ $^\circ\text{C}$ above 75 $^\circ\text{C}$.



SPECIFICATIONS ^a (for dual supplies)							
Parameter	Symbol	Test Conditions Unless Otherwise Specified V ₊ = 15 V, V ₋ = - 15 V V _L = 5 V, V _{IN} = 2.4 V, 0.8 V ^e	Temp. ^b	Limits - 40 °C to 85 °C			Unit
				Min. ^d	Typ. ^c	Max. ^d	
Analog Switch							
Analog Signal Range ^e	V _{ANALOG}		Full	- 15		15	V
Drain-Source On-Resistance	R _{DS(on)}	I _S = 1 mA, V _D = ± 10 V	Room Full		45	80 95	Ω
On-Resistance Match Between Channels ^e	ΔR _{DS(on)}	I _S = 1 mA, V _D = ± 10 V	Room Full		2	4 5	
Switch Off Leakage Current	I _{S(off)}	V _D = ± 14 V, V _S = ± 14 V	Room Full	- 0.5 - 5	± 0.01	0.5 5	nA
	I _{D(off)}		Room Full	- 0.5 - 5	± 0.01	0.5 5	
Channel On Leakage Current	I _{D(on)}	V _S = V _D = ± 14 V	Room Full	- 0.5 - 10	± 0.02	0.5 10	
Digital Control							
Input Voltage Low	V _{INL}		Full			0.8	V
Input Voltage High	V _{INH}		Full	2.4			
Input Current V _{IN} Low	I _{INL}	V _{IN} under test = 0.8 V All Other = 2.4 V	Full	- 1	- 0.01	1	μA
Input Current V _{IN} High	I _{INH}	V _{IN} under test = 2.4 V All Other = 0.8 V	Full	- 1	0.01	1	
Dynamic Characteristics							
Turn-On Time	t _{ON}	R _L = 1 kΩ, C _L = 35 pF V _S = 10 V, See Figure 2	Room			120	ns
Turn-Off Time	t _{OFF}		Room			65	
Charge Injection ^e	Q	C _L = 1 nF, V _S = 0 V V _{gen} = 0 V, R _{gen} = 0 Ω	Room		- 1		pC
Off Isolation ^e	OIRR	R _L = 50 Ω, C _L = 15 pF V _S = 1 V _{RMS} , f = 100 kHz	Room		- 90		dB
Crosstalk (Channel-to-Channel)	X _{TALK}		Room		- 95		
Source Off Capacitance ^e	C _{S(off)}	f = 1 MHz	Room		4		pF
Drain Off Capacitance ^e	C _{D(off)}		Room		4		
Channel On Capacitance ^e	C _{D(on)}	V _S = V _D = 0 V, f = 1 MHz	Room		16		
Power Supplies							
Positive Supply Current	I ₊	V ₊ = 16.5 V, V ₋ = - 16.5 V V _{IN} = 0 or 5 V	Room Full			1 5	μA
Negative Supply Current	I ₋		Room Full	- 1 - 5			

SPECIFICATIONS (for single supply)							
Parameter	Symbol	Test Conditions Unless Otherwise Specified $V_+ = 12\text{ V}$, $V_- = 0\text{ V}$ $V_{IN} = 2.4\text{ V}$, 0.8 V^e	Temp. ^b	Limits - 40 °C to 85 °C			Unit
				Min. ^d	Typ. ^c	Max. ^d	
Analog Switch							
Analog Signal Range ^e	V_{ANALOG}		Full	0		12	V
Drain-Source On-Resistance	$R_{DS(on)}$	$I_S = 1\text{ mA}$, $V_D = 3\text{ V}$, 8 V	Room Full		90	160 200	Ω
Dynamic Characteristics							
Turn-On Time	t_{ON}	$R_L = 1\text{ k}\Omega$, $C_L = 35\text{ pF}$, $V_S = 8\text{ V}$	Room		120	300	ns
Turn-Off Time	t_{OFF}	See Figure 2	Room		60	200	
Charge Injection	Q	$C_L = 1\text{ nF}$, $V_{gen} = 6\text{ V}$, $R_{gen} = 0\text{ }\Omega$	Room		4		pC
Power Supplies							
Positive Supply Current	I_+	$V_{IN} = 0\text{ V}$ or 5 V	Room Full			1 5	μA
Negative Supply Current	I_-		Room Full	- 1 - 5			

Notes:

- Refer to PROCESS OPTION FLOWCHART.
- Room = 25 °C, Full = as determined by the operating temperature suffix.
- Typical values are for DESIGN AID ONLY, not guaranteed nor subject to production testing.
- The algebraic convention whereby the most negative value is a minimum and the most positive a maximum, is used in this data sheet.
- Guaranteed by design, not subject to production test.
- V_{IN} = input voltage to perform proper function.

Stresses beyond those listed under "Absolute Maximum Ratings" may cause permanent damage to the device. These are stress ratings only, and functional operation of the device at these or any other conditions beyond those indicated in the operational sections of the specifications is not implied. Exposure to absolute maximum rating conditions for extended periods may affect device reliability.

SCHEMATIC DIAGRAM (typical channel)

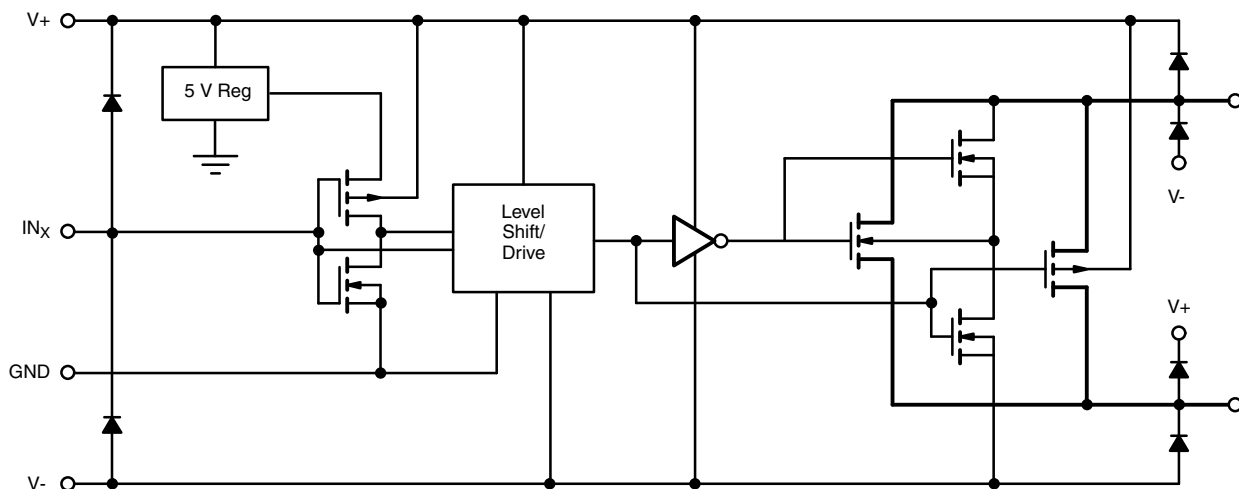
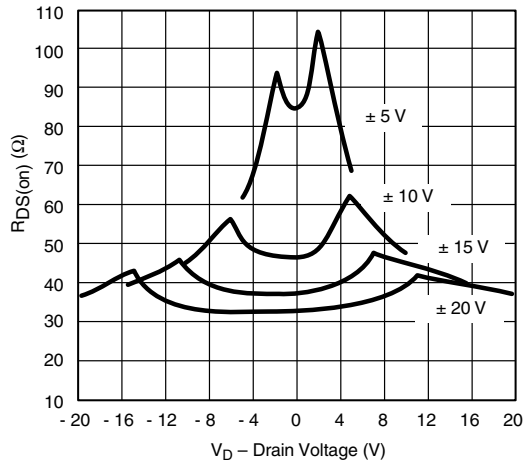
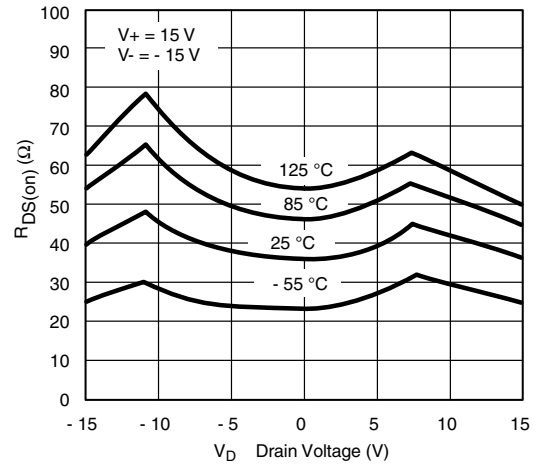
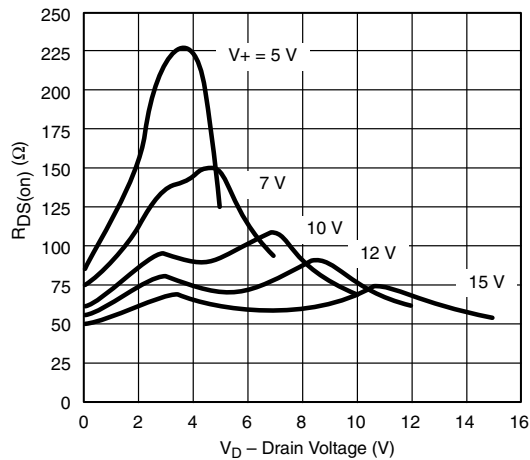
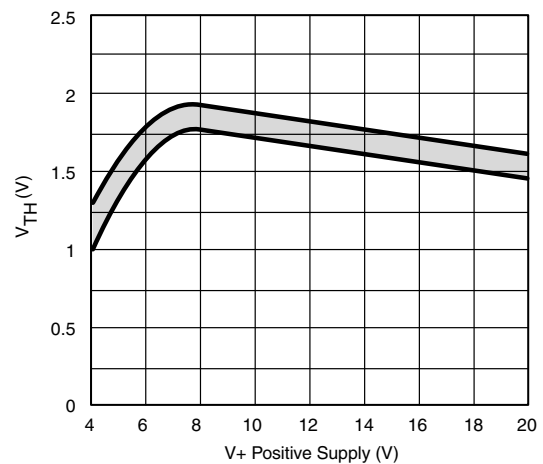
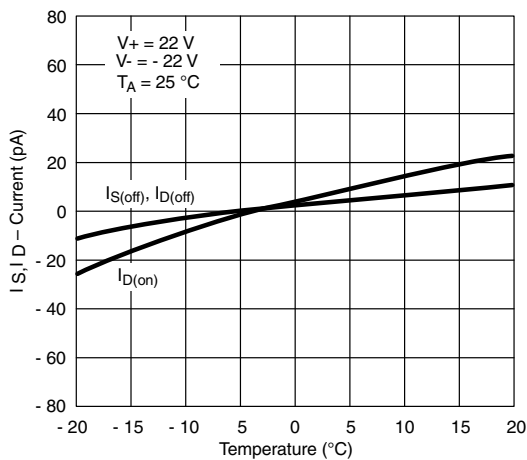
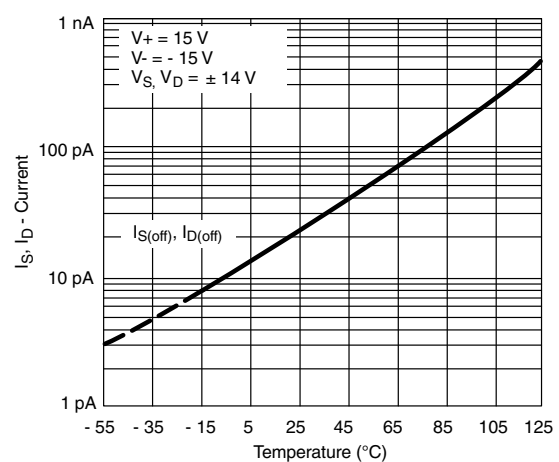
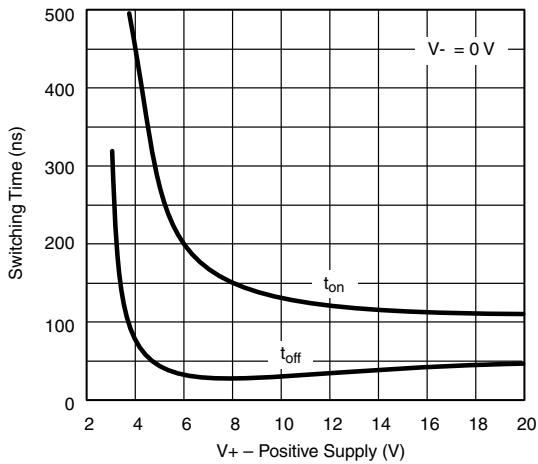

Figure 1.

TYPICAL CHARACTERISTICS ($T_A = 25\text{ }^\circ\text{C}$, unless otherwise noted)

 $R_{DS(on)}$ vs. V_D and Power Supply Voltages

 $R_{DS(on)}$ vs. V_D and Temperature

 $R_{DS(on)}$ vs. V_D and Single Power Supply Voltages

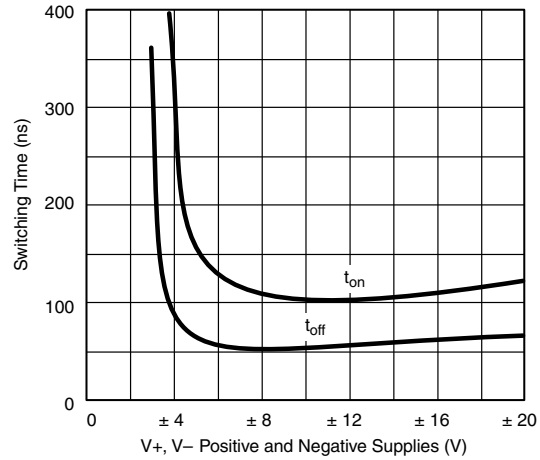
Input Switching Threshold vs. Supply Voltage

Leakage Currents vs. Analog Voltage

Leakage Currents vs. Temperature

TYPICAL CHARACTERISTICS ($T_A = 25\text{ }^\circ\text{C}$, unless otherwise noted)



Switching Time vs. Single Supply Voltage



Switching Times vs. Power Supply Voltage

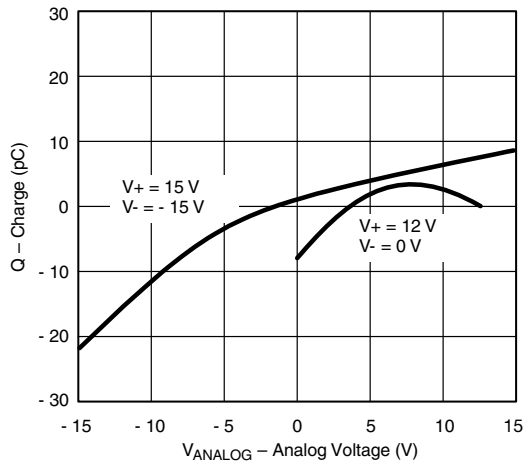

Q_S, Q_D - Charge Injection vs. Analog Voltage

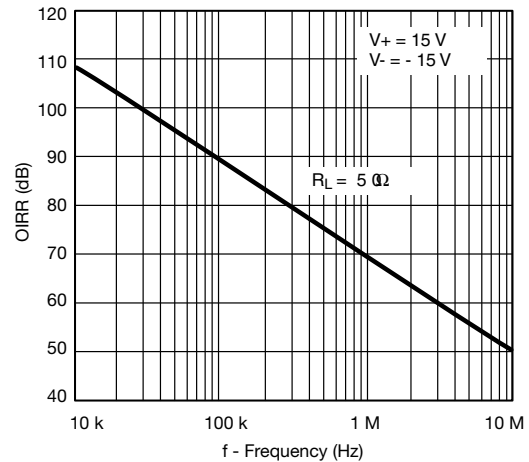

Off Isolation vs. Frequency

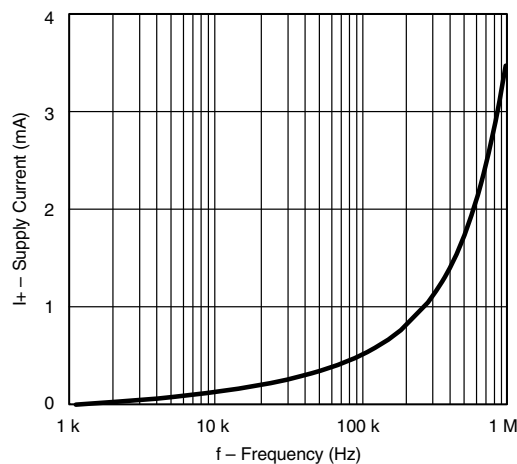

Supply Current vs. Switching Frequency

TEST CIRCUITS

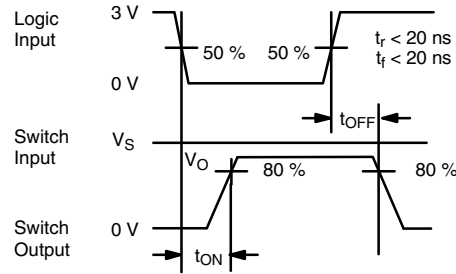
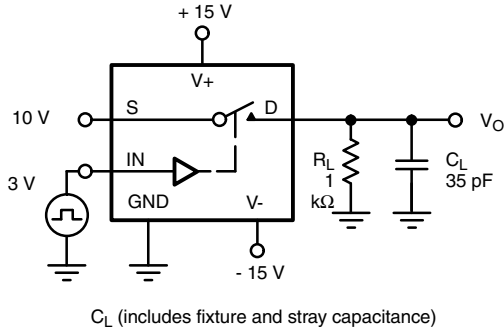

Note: Logic input waveform is inverted for DG442.

Figure 2. Switching Time

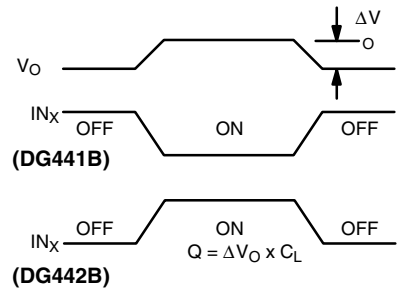
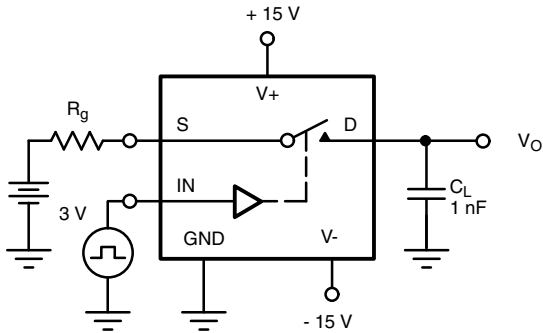

Figure 3. Charge Injection

$C = 1 \text{ mF}$ tantalum in parallel with 0.01 mF ceramic

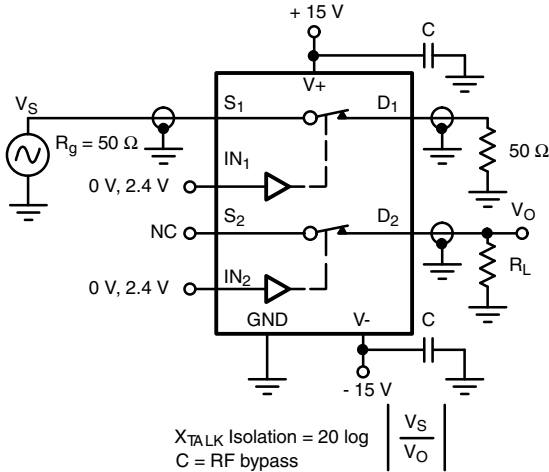

Figure 4. Crosstalk

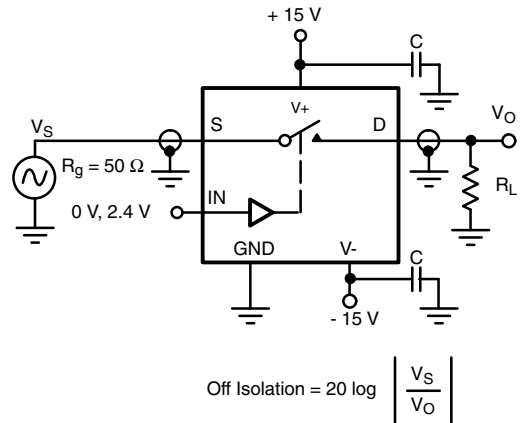

Figure 5. Off Isolation

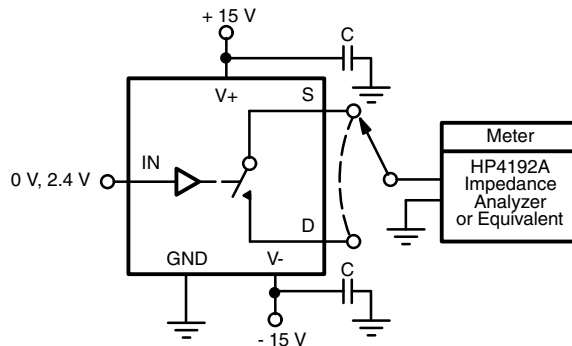

Figure 6. Source/Drain Capacitances

APPLICATIONS

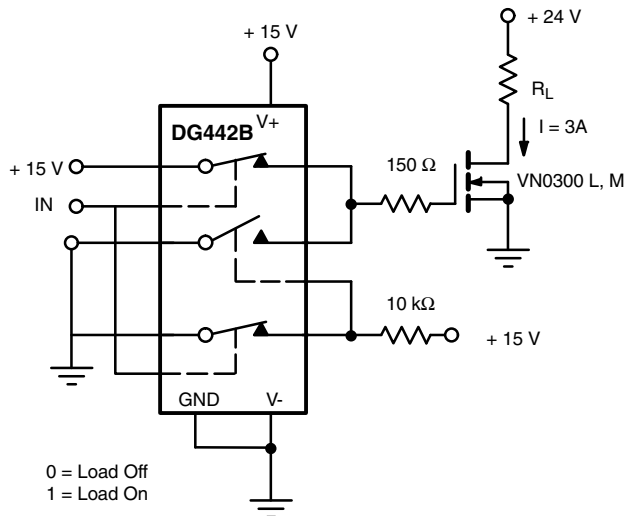

Figure 7. Power MOSFET Driver

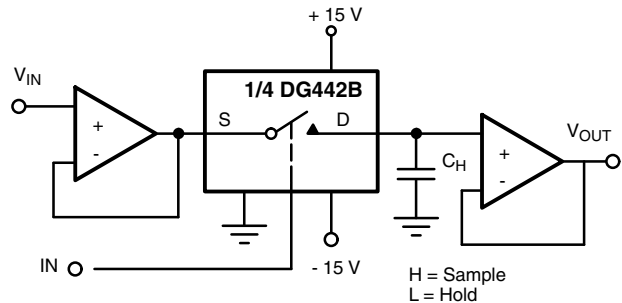
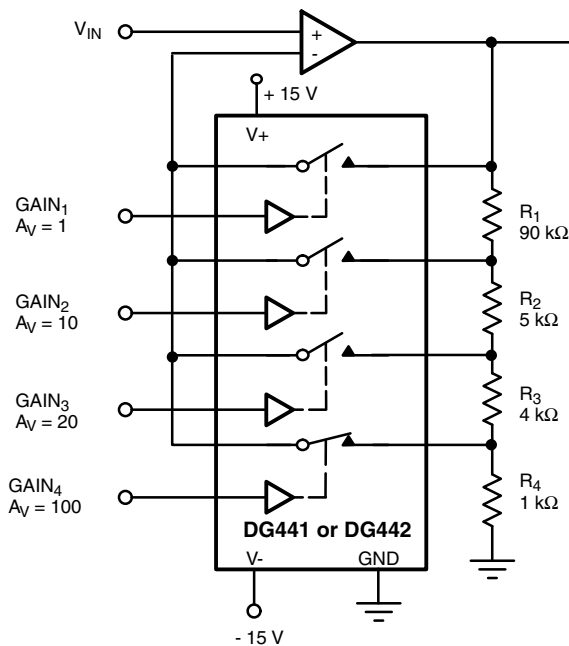

Figure 8. Open Loop Sample-and-Hold



Gain error is determined only by the resistor tolerance. Op amp offset and CMRR will limit accuracy of circuit.

With SW₄ Closed

$$\frac{V_{OUT}}{V_{IN}} = \frac{R_1 + R_2 + R_3 + R_4}{R_4} = 100$$

Figure 9. Precision-Weighted Resistor Programmable-Gain Amplifier

Vishay Siliconix maintains worldwide manufacturing capability. Products may be manufactured at one of several qualified locations. Reliability data for Silicon Technology and Package Reliability represent a composite of all qualified locations. For related documents such as package/tape drawings, part marking, and reliability data, see www.vishay.com/ppg?72625.



SOIC (NARROW): 16-LEAD
JEDEC Part Number: MS-012

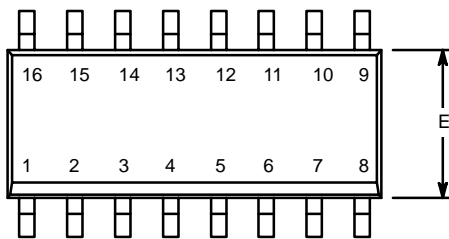

Dim	MILLIMETERS		INCHES	
	Min	Max	Min	Max
A	1.35	1.75	0.053	0.069
A ₁	0.10	0.20	0.004	0.008
B	0.38	0.51	0.015	0.020
C	0.18	0.23	0.007	0.009
D	9.80	10.00	0.385	0.393
E	3.80	4.00	0.149	0.157
e	1.27 BSC		0.050 BSC	
H	5.80	6.20	0.228	0.244
L	0.50	0.93	0.020	0.037
∅	0°	8°	0°	8°

ECN: S-03946—Rev. F, 09-Jul-01
DWG: 5300

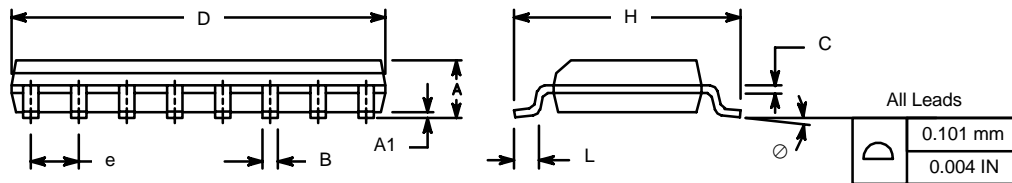



PDIP: 16-LEAD

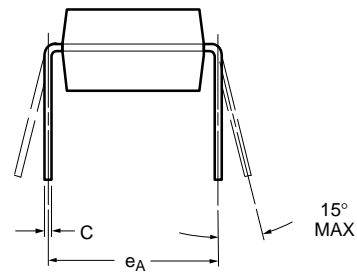
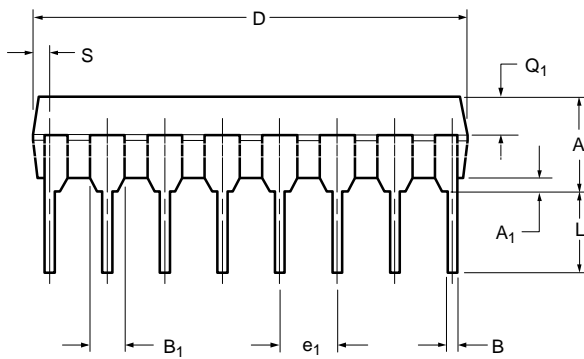
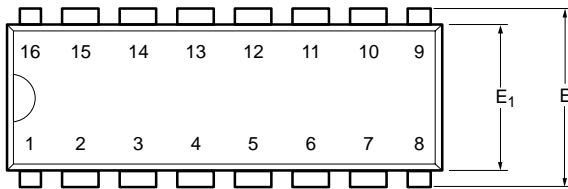

Dim	MILLIMETERS		INCHES	
	Min	Max	Min	Max
A	3.81	5.08	0.150	0.200
A₁	0.38	1.27	0.015	0.050
B	0.38	0.51	0.015	0.020
B₁	0.89	1.65	0.035	0.065
C	0.20	0.30	0.008	0.012
D	18.93	21.33	0.745	0.840
E	7.62	8.26	0.300	0.325
E₁	5.59	7.11	0.220	0.280
e₁	2.29	2.79	0.090	0.110
e_A	7.37	7.87	0.290	0.310
L	2.79	3.81	0.110	0.150
Q₁	1.27	2.03	0.050	0.080
S	0.38	1.52	.015	0.060

ECN: S-03946—Rev. D, 09-Jul-01
DWG: 5482

Vishay Siliconix

QFN-16 (4 × 4 mm)

JEDEC Part Number: MO-220

Dim	MILLIMETERS*			INCHES			Notes
	Min	Nom	Max	Min	Nom	Max	
A	0.80	0.90	1.00	0.0315	0.0354	0.0394	
A1	0	0.02	0.05	0	0.0008	0.0020	
A3	-	0.20 Ref	-	-	0.0079	-	
AA	-	0.345	-	-	0.0136	-	
aaa	-	0.25	-	-	0.0098	-	
BB	-	0.345	-	-	0.0136	-	
b	0.23	0.30	0.38	0.0091	0.0118	0.0150	5
bbb	-	0.10	-	-	0.0039	-	
CC	-	0.18	-	-	0.0071	-	
ccc	-	0.10	-	-	0.0039	-	
D	4.00 BSC			0.1575 BSC			
D2	2.00	2.15	2.25	0.0787	0.0846	0.0886	
DD	-	0.18	-	-	0.0071	-	
E	4.00 BSC			0.1575 BSC			
E2	2.00	2.15	2.25	0.0787	0.0846	0.0886	
e	0.65 BSC			0.0256 BSC			
L	0.45	0.55	0.65	0.0177	0.0217	0.0256	
N	16			16			3, 7
ND	-	4	-	-	4	-	6
NE	-	4	-	-	4	-	6
r	b(min)/2	-	-	b(min)/2	-	-	

* Use millimeters as the primary measurement.

ECN: S-21437—Rev. A, 19-Aug-02
DWG: 5890

NOTES:

1. Dimensioning and tolerancing conform to ASME Y14.5M-1994.
2. All dimensions are in millimeters. All angles are in degrees.
3. N is the total number of terminals.
4. The terminal #1 identifier and terminal numbering convention shall conform to JESD 95-1 SPP-012. Details of terminal #1 identifier are optional, but must be located within the zone indicated. The terminal #1 identifier may be either a molded or marked feature. The X and Y dimension will vary according to lead counts.
5. Dimension b applies to metallized terminal and is measured between 0.25 mm and 0.30 mm from the terminal tip.
6. ND and NE refer to the number of terminals on the D and E side respectively.
7. Depopulation is possible in a symmetrical fashion.
8. Variation HHD is shown for illustration only.
9. Coplanarity applies to the exposed heat sink slug as well as the terminals.

RECOMMENDED MINIMUM PADS FOR SO-16

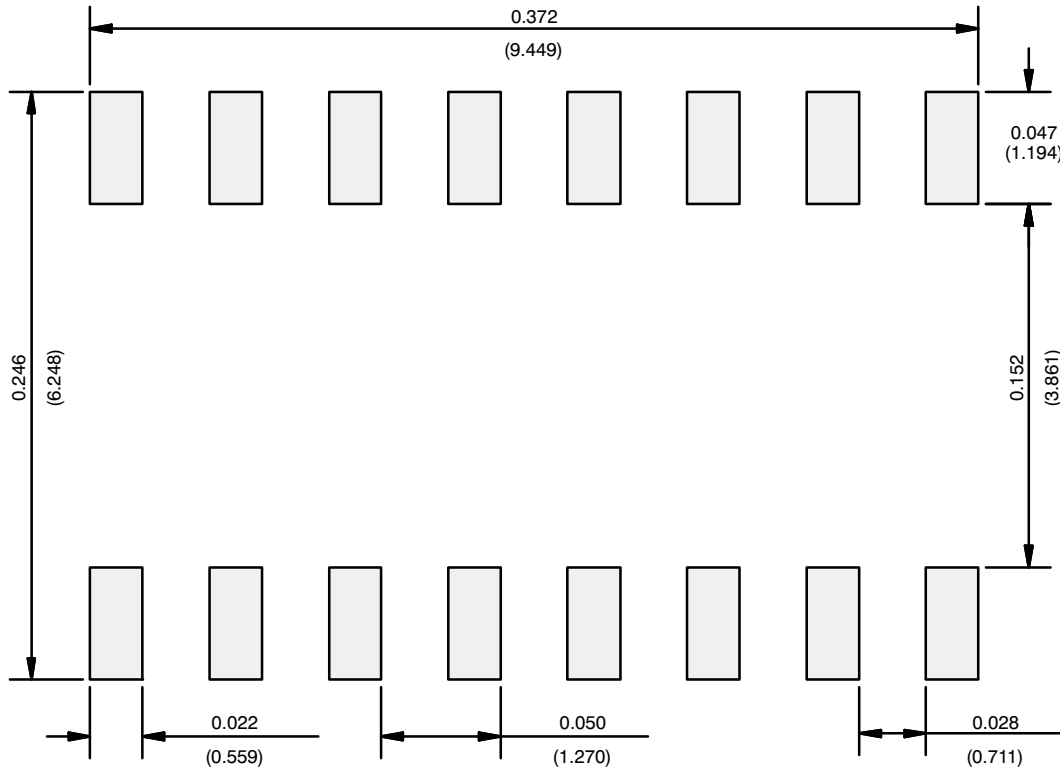

Recommended Minimum Pads
Dimensions in Inches/(mm)

[Return to Index](#)

RECOMMENDED MINIMUM PADS FOR QFN-16 (4 x 4 MM BODY)

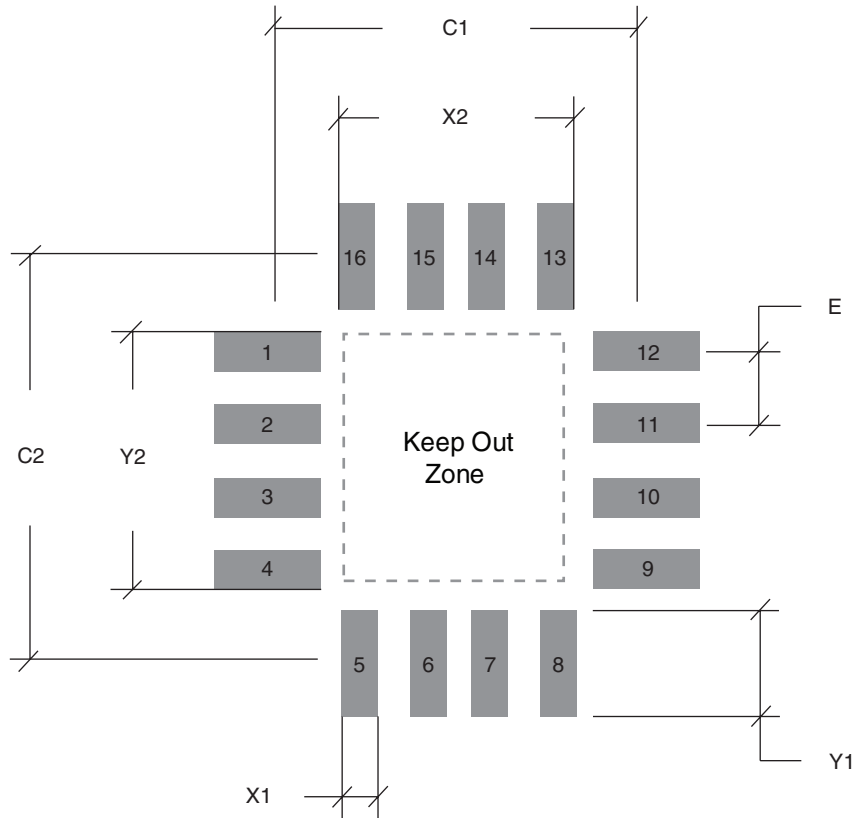

	Inches	Millimeters
C1	0.142	3.60
C2	0.142	3.60
E	0.026	0.65
X1	0.014	0.35
X2	0.089	2.25
Y1	0.037	0.95
Y2	0.089	2.25

Note:
QFN-16 (4 x 4) has an exposed center pad that must not come into contact with any metalized structure on the PCB. This area is considered a Keep Out Zone.



Disclaimer

ALL PRODUCT, PRODUCT SPECIFICATIONS AND DATA ARE SUBJECT TO CHANGE WITHOUT NOTICE TO IMPROVE RELIABILITY, FUNCTION OR DESIGN OR OTHERWISE.

Vishay Intertechnology, Inc., its affiliates, agents, and employees, and all persons acting on its or their behalf (collectively, "Vishay"), disclaim any and all liability for any errors, inaccuracies or incompleteness contained in any datasheet or in any other disclosure relating to any product.

Vishay makes no warranty, representation or guarantee regarding the suitability of the products for any particular purpose or the continuing production of any product. To the maximum extent permitted by applicable law, Vishay disclaims (i) any and all liability arising out of the application or use of any product, (ii) any and all liability, including without limitation special, consequential or incidental damages, and (iii) any and all implied warranties, including warranties of fitness for particular purpose, non-infringement and merchantability.

Statements regarding the suitability of products for certain types of applications are based on Vishay's knowledge of typical requirements that are often placed on Vishay products in generic applications. Such statements are not binding statements about the suitability of products for a particular application. It is the customer's responsibility to validate that a particular product with the properties described in the product specification is suitable for use in a particular application. Parameters provided in datasheets and/or specifications may vary in different applications and performance may vary over time. All operating parameters, including typical parameters, must be validated for each customer application by the customer's technical experts. Product specifications do not expand or otherwise modify Vishay's terms and conditions of purchase, including but not limited to the warranty expressed therein.

Except as expressly indicated in writing, Vishay products are not designed for use in medical, life-saving, or life-sustaining applications or for any other application in which the failure of the Vishay product could result in personal injury or death. Customers using or selling Vishay products not expressly indicated for use in such applications do so at their own risk and agree to fully indemnify and hold Vishay and its distributors harmless from and against any and all claims, liabilities, expenses and damages arising or resulting in connection with such use or sale, including attorneys fees, even if such claim alleges that Vishay or its distributor was negligent regarding the design or manufacture of the part. Please contact authorized Vishay personnel to obtain written terms and conditions regarding products designed for such applications.

No license, express or implied, by estoppel or otherwise, to any intellectual property rights is granted by this document or by any conduct of Vishay. Product names and markings noted herein may be trademarks of their respective owners.

Material Category Policy

Vishay Intertechnology, Inc. hereby certifies that all its products that are identified as RoHS-Compliant fulfill the definitions and restrictions defined under Directive 2011/65/EU of The European Parliament and of the Council of June 8, 2011 on the restriction of the use of certain hazardous substances in electrical and electronic equipment (EEE) - recast, unless otherwise specified as non-compliant.

Please note that some Vishay documentation may still make reference to RoHS Directive 2002/95/EC. We confirm that all the products identified as being compliant to Directive 2002/95/EC conform to Directive 2011/65/EU.