

## 2 Port, USB 2.0 High Speed (480 Mbps) Switch, DPDT Analog Switch

### DESCRIPTION

The DG2722 is 2 port high speed analog switch optimized for USB 2.0 signal switching. The DG2722 switch is configured in DPDT. It handles bidirectional signal flow, achieving a 900 MHz - 3 dB bandwidth, and a port to port crosstalk and isolation at - 49 dB.

Processed with high density sub micron CMOS, the DG2722 provide low parasitic capacitance. Signals are routed with minimized phase distortion and attain a bit to bit skew as low as 40 pS.

The DG2722 is designed for a wide range of operating voltages, from 2.7 V to 4.3 V that can be driven directly from one cell Li-ion battery. On-chip circuitry protects against conditions when either the D+/D- lines are shorted to the  $V_{BUS}$  at the USB port. Additionally, logic control pins (S and  $\overline{OE}$ ) can tolerate the presence of voltages that are above the supply power rail ( $V_+$ ). The control logic threshold is guaranteed to be ( $V_{IH} = 1.3$  V/min). Latch up current is 300 mA, as per JESD78, and its ESD tolerance exceeds 8 kV.

Packaged in ultra small miniQFN-10 (1.4 mm x 1.8 mm x 0.55 mm), it is ideal for portable high speed mix signal switching application.

As a committed partner to the community and the environment, Vishay Siliconix manufactures this product with lead (Pb)-free device termination. The miniQFN-10 package has a nickel-palladium-gold device termination and is represented by the lead (Pb)-free “-E4” suffix to the ordering part number. The nickel-palladium-gold device terminations meet all JEDEC standards for reflow and MSL rating.

As a further sign of Vishay Siliconix's commitment, the DG2722 is fully RoHS compliant.

### FEATURES

- **Halogen-free according to IEC 61249-2-21 Definition**
- Wide operation voltage range
- Low on-resistance,  $7 \Omega$  (typical at 3 V)
- Low capacitance,  $C_{ON} = 5.8$  pF (typical)
- 3 dB high bandwidth: 900 MHz (typical)
- Low bit to bit skew: 40 pS (typical)
- Low power consumption
- Low logic threshold: V
- Power down protection: D+/D- pins can tolerate up to 5 V when  $V_+ = 0$  V
- Logic (S and  $\overline{OE}$ ) above  $V_+$  tolerance
- 8 kV ESD protection (HBM)
- Latch-up current 300 mA per JESD78
- Lead (Pb)-free low profile miniQFN-10 (1.4 mm x 1.8 mm x 0.55 mm)
- **Compliant to RoHS Directive 2002/95/EC**



**RoHS**  
COMPLIANT  
HALOGEN  
**FREE**

### APPLICATIONS

- Cellular phones
- Portable media players
- PDA
- Digital camera
- GPS
- Notebook computer
- TV, monitor, and set top box

### FUNCTIONAL BLOCK DIAGRAM AND PIN CONFIGURATION

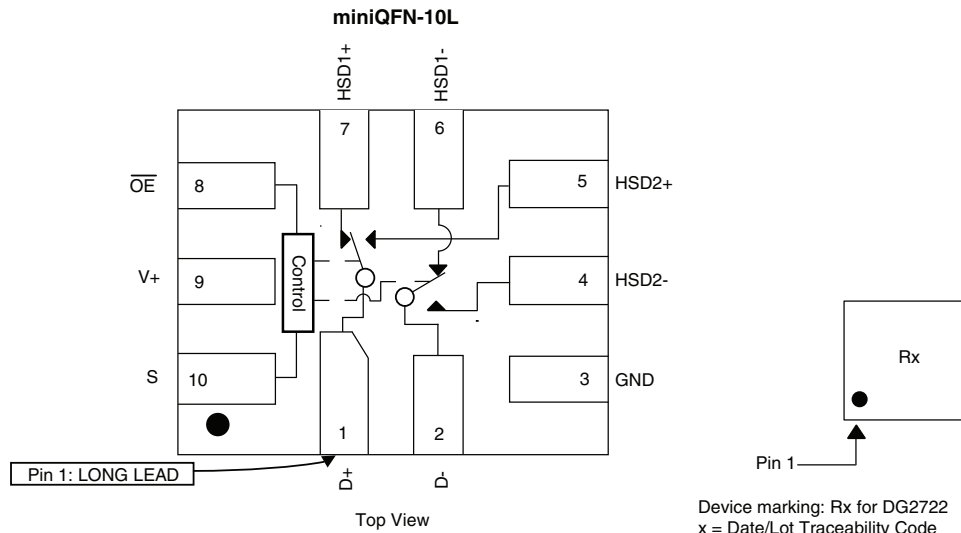



ORDERING INFORMATION		
Temp. Range	Package	Part Number
- 40 °C to 85 °C	miniQFN-10	DG2722DN-T1-E4

TRUTH TABLE		
$\overline{OE}$ (Pin 8)	S (Pin 10)	Function
0	0	D+ = HSD1+ and D- = HSD1-
0	1	D+ = HSD2+ and D- = HSD2-
1	X	Disconnect

PIN DESCRIPTIONS	
Pin Name	Description
$\overline{OE}$	Bus Switch Enable
S	Select Input
HSD1±, HSD2±, D±	Data Port

ABSOLUTE MAXIMUM RATINGS (T <sub>A</sub> = 25 °C, unless otherwise noted)			
Parameter		Limit	Unit
Reference to GND	V+	- 0.3 to 5	V
	S, $\overline{OE}$ , D±, HSD1±, HSD2± <sup>a</sup>	- 0.3 to (V+ + 0.3)	
Current (Any Terminal except S, $\overline{OE}$ , D±, HSD1±, HSD2±)		30	mA
Continuous Current (S, $\overline{OE}$ , D±, HSD1±, HSD2±)		± 250	
Peak Current (Pulsed at 1 ms, 10 % Duty Cycle)		± 500	
Storage Temperature (D Suffix)		- 65 to 150	°C
Power Dissipation (Packages) <sup>b</sup>	miniQFN-10 <sup>c</sup>	208	mW
ESD (Human Body Model) I/O to GND		8	kV
Latch-up (Current Injection)		300	mA

Notes:

- a. Signals on S,  $\overline{OE}$ , D±, HSD1±, HSD2± exceeding V+ will be clamped by internal diodes. Limit forward diode current to maximum current ratings.
- b. All leads welded or soldered to PC board.
- c. Derate 2.6 mW/°C above 70 °C.

SPECIFICATIONS (V+ = 3 V)							
Parameter	Symbol	Test Conditions Otherwise Unless Specified	Temp. <sup>a</sup>	Limits - 40 °C to 85 °C			Unit
				Min. <sup>b</sup>	Typ. <sup>c</sup>	Max. <sup>b</sup>	
<b>Analog Switch</b>							
Analog Signal Range <sup>d</sup>	V <sub>ANALOG</sub>	R <sub>DS(on)</sub>	Full	0		V+	V
On-Resistance	R <sub>DS(on)</sub>	V+ = 3 V, I <sub>D±</sub> = 8 mA, V <sub>HSD1/2±</sub> = 0.4 V	Room		7	8	Ω
			Full			9	
On-Resistance Match <sup>d</sup>	ΔR <sub>ON</sub>	V+ = 3 V, I <sub>D±</sub> = 8 mA, V <sub>HSD1/2±</sub> = 0.4 V	Room		0.8		Ω
On-Resistance Resistance Flatness <sup>d</sup>	R <sub>ON Flatness</sub>	V+ = 3 V, I <sub>D±</sub> = 8 mA, V <sub>HSD1/2±</sub> = 0 V, 1 V	Room		2		
Switch Off Leakage Current	I <sub>(off)</sub>	V+ = 4.3 V, V <sub>HSD1/2±</sub> = 0.3 V, 3 V, V <sub>D±</sub> = 3 V, 0.3 V	Full	- 100		100	nA
Channel On Leakage Current	I <sub>(on)</sub>	V+ = 4.3 V, V <sub>HSD1/2±</sub> = 0.3 V, 4 V, V <sub>D±</sub> = 4 V, 0.3 V	Full	- 200		200	
<b>Digital Control</b>							
Input Voltage High	V <sub>INH</sub>	V+ = 3 V to 3.6 V	Full	1.3			V
		V+ = 4.3 V	Full	1.5			
Input Voltage Low	V <sub>INL</sub>	V+ = 3 V to 4.3 V	Full			0.5	
Input Capacitance	C <sub>IN</sub>		Full		6.5		pF
Input Current	I <sub>INL</sub> or I <sub>INH</sub>	V <sub>IN</sub> = 0 or V+	Full	- 1		1	μA



SPECIFICATIONS (V+ = 3 V)							
Parameter	Symbol	Test Conditions Otherwise Unless Specified	Temp. <sup>a</sup>	Limits - 40 °C to 85 °C			Unit
				Min. <sup>b</sup>	Typ. <sup>c</sup>	Max. <sup>b</sup>	
<b>Dynamic Characteristics</b>							
Break-Before-Make Time <sup>e, d</sup>	t <sub>BBM</sub>	V+ = 3 V, V <sub>D1/2±</sub> = 1.5 V, R <sub>L</sub> = 50 Ω, C <sub>L</sub> = 35 pF	Room		5		ns
S, $\overline{OE}$ Turn-On Time <sup>e, d</sup>	t <sub>ON</sub>		Room			30	
S, $\overline{OE}$ Turn-Off Time <sup>e, d</sup>	t <sub>OFF</sub>		Room			25	
			Full				
Charge Injection <sup>d</sup>	Q <sub>INJ</sub>	C <sub>L</sub> = 1 nF, R <sub>GEN</sub> = 0 Ω, V <sub>GEN</sub> = 0 V	Room		0.5		pC
Off-Isolation <sup>d</sup>	OIRR	V+ = 3 V to 3.6 V, R <sub>L</sub> = 50 Ω, C <sub>L</sub> = 5 pF, f = 240 MHz			- 30		dB
Crosstalk <sup>d</sup>	X <sub>TALK</sub>				- 45		
Bandwidth <sup>d</sup>	BW	V+ = 3 V to 3.6 V, R <sub>L</sub> = 50 Ω, - 3 dB			900		MHz
D+/D- On Capacitance	C <sub>ON</sub>	V+ = 3.3 V, $\overline{OE}$ = 0 V, f = 240 MHz			5.8		pF
D1n, D2n Off Capacitance	C <sub>OFF</sub>	V+ = $\overline{OE}$ = 3.3 V, f = 240 MHz			2.2		
Channel-to-Channel Skew <sup>d</sup>	t <sub>SK(O)</sub>	V+ = 3 V to 3.6 V, R <sub>L</sub> = 50 Ω, C <sub>L</sub> = 5 pF			50		ps
Skew Off Opposite Transitions of the Same Output <sup>d</sup>	t <sub>SK(p)</sub>				20		
Total Jitter <sup>d</sup>	t <sub>J</sub>				200		
<b>Power Supply</b>							
Power Supply Range	V+			2.6		4.3	V
Power Supply Current	I+	V <sub>IN</sub> = 0 V, or V+	Full			2	μA

Notes:

- a. Room = 25 °C, Full = as determined by the operating suffix.
- b. The algebraic convention whereby the most negative value is a minimum and the most positive a maximum, is used in this datasheet.
- c. Typical values are for design aid only, not guaranteed nor subject to production testing.
- d. Guarantee by design, not subjected to production test.
- e. V<sub>IN</sub> = input voltage to perform proper function.
- f. Crosstalk measured between channels.

Stresses beyond those listed under "Absolute Maximum Ratings" may cause permanent damage to the device. These are stress ratings only, and functional operation of the device at these or any other conditions beyond those indicated in the operational sections of the specifications is not implied. Exposure to absolute maximum rating conditions for extended periods may affect device reliability.

**TYPICAL CHARACTERISTICS** ( $T_A = 25\text{ }^\circ\text{C}$ , unless otherwise noted)

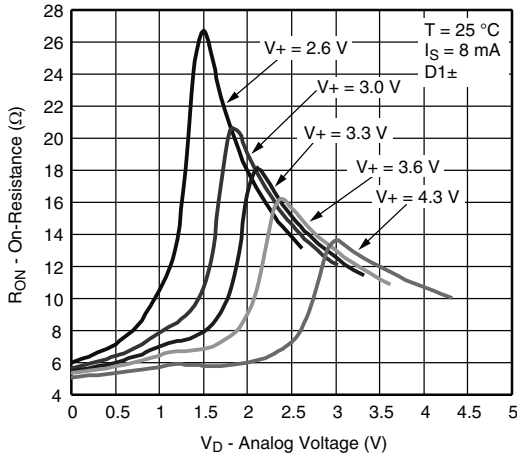

**$R_{ON}$  vs.  $V_D$  and Single Supply Voltage**

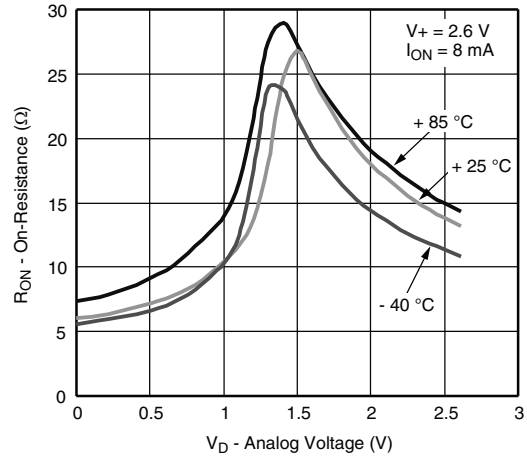

**$R_{ON}$  vs. Analog Voltage and Temperature**

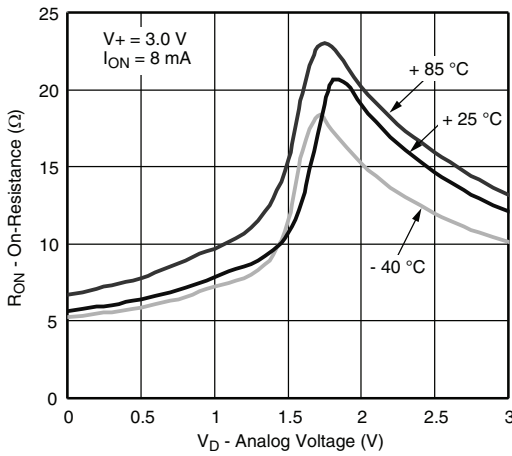

**$R_{ON}$  vs. Analog Voltage and Temperature**

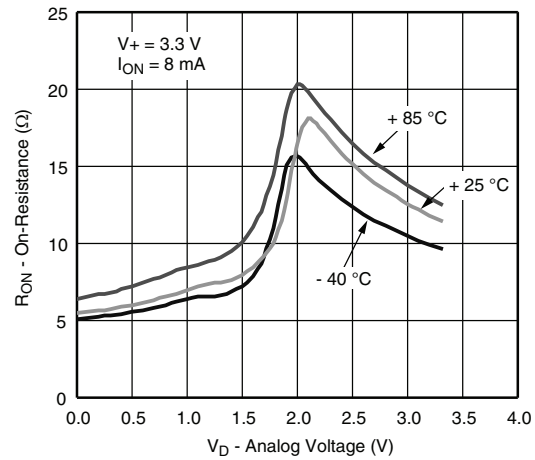

**$R_{ON}$  vs. Analog Voltage and Temperature**

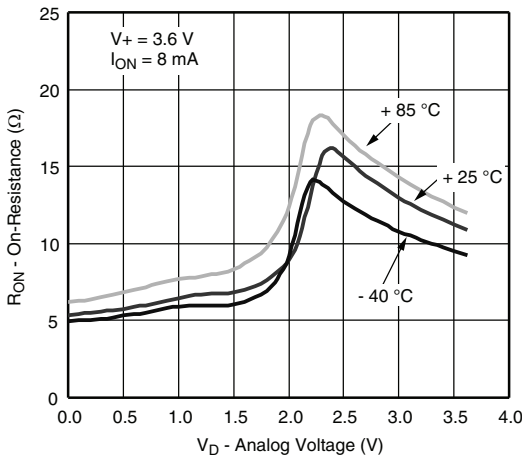

**$R_{ON}$  vs. Analog Voltage and Temperature**

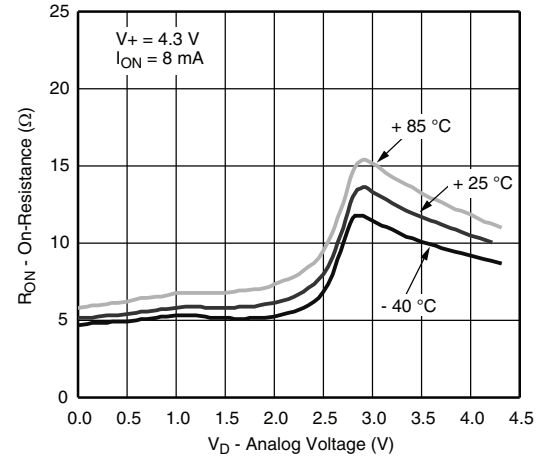

**$R_{ON}$  vs. Analog Voltage and Temperature**

**TYPICAL CHARACTERISTICS** ( $T_A = 25\text{ }^\circ\text{C}$ , unless otherwise noted)

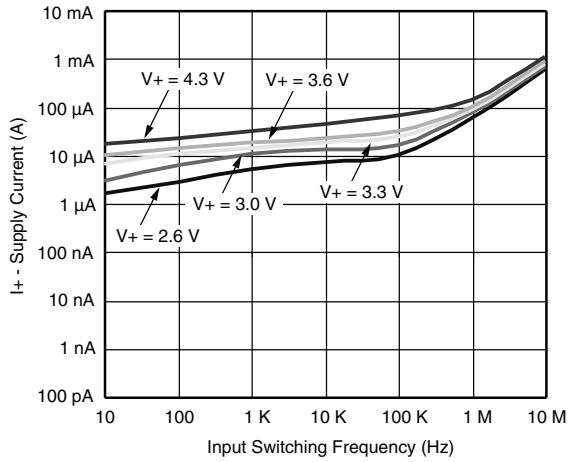

**Supply Current vs. Input Switching Frequency**

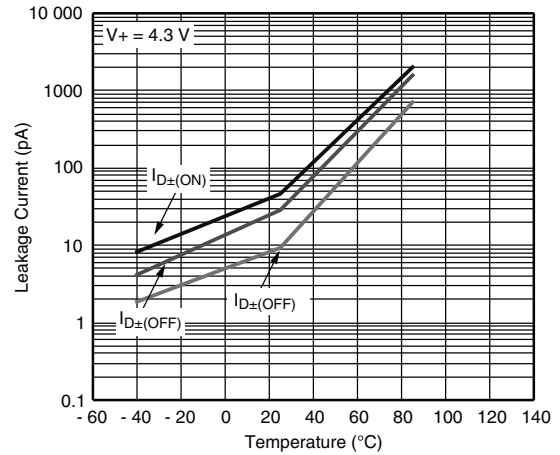

**Leakage Current vs. Temperature**

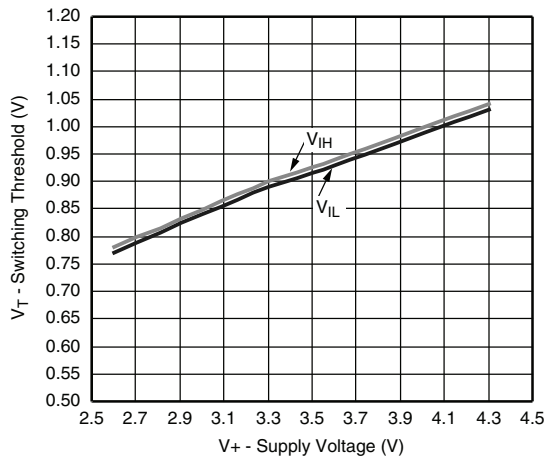

**Switching Threshold vs. Supply Voltage**

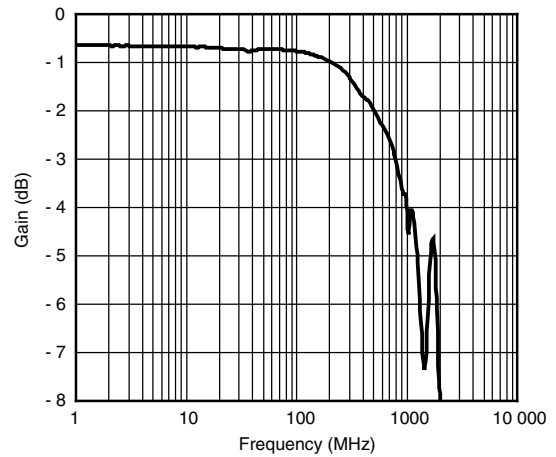

**Gain vs. Frequency,  $V_+ = 3.3\text{ V}$**

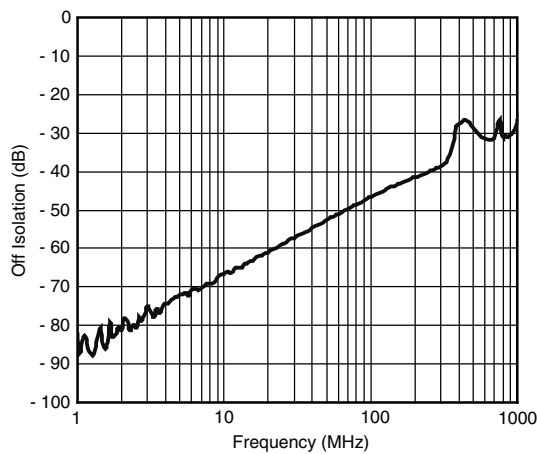

**Off-Isolation,  $V_+ = 3.3\text{ V}$**

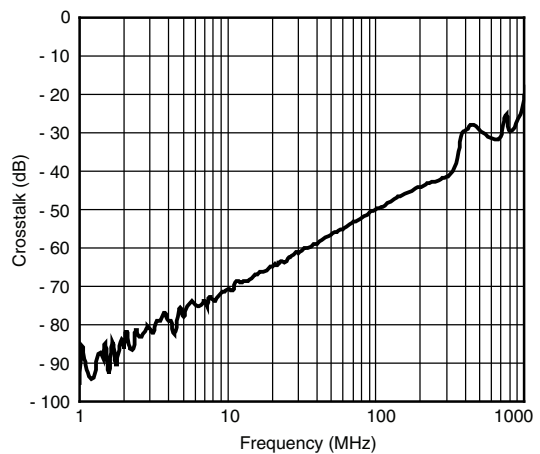

**Crosstalk,  $V_+ = 3.3\text{ V}$**

TEST CIRCUITS

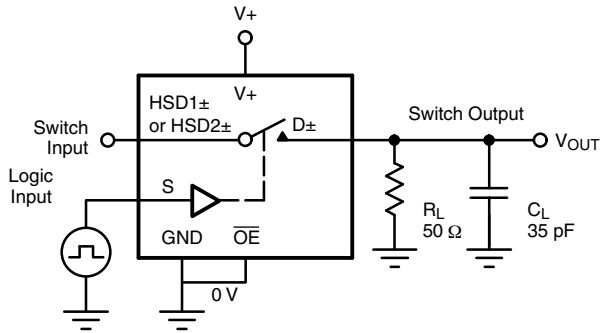

$C_L$  (includes fixture and stray capacitance)

$$V_{OUT} = D_{\pm} \left( \frac{R_L}{R_L + R_{ON}} \right)$$

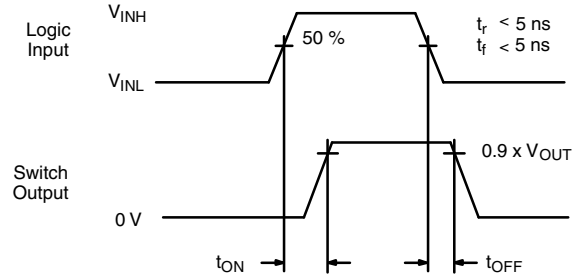

Logic "1" = Switch on  
Logic input waveforms inverted for switches that have the opposite logic sense.

Figure 1. Switching Time

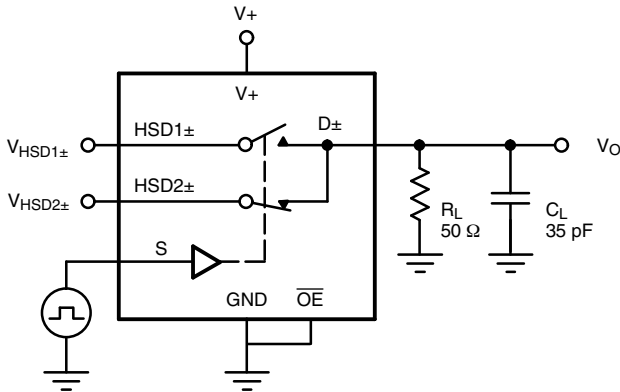

$C_L$  (includes fixture and stray capacitance)

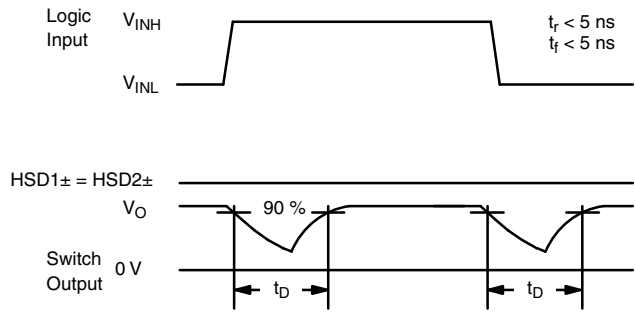
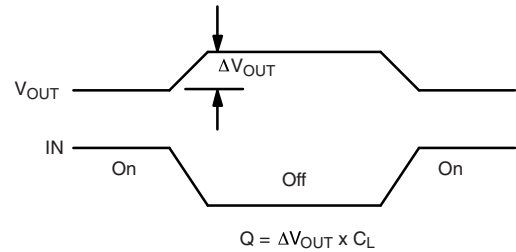
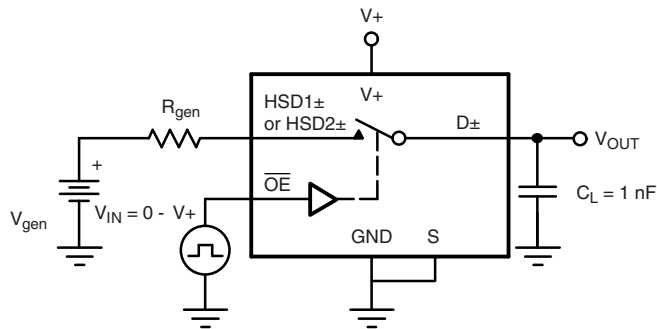
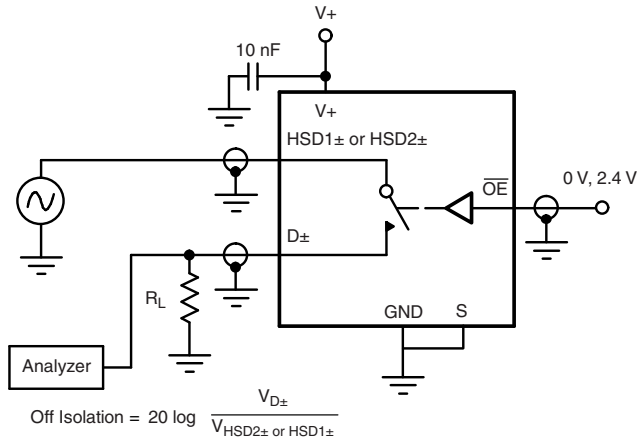
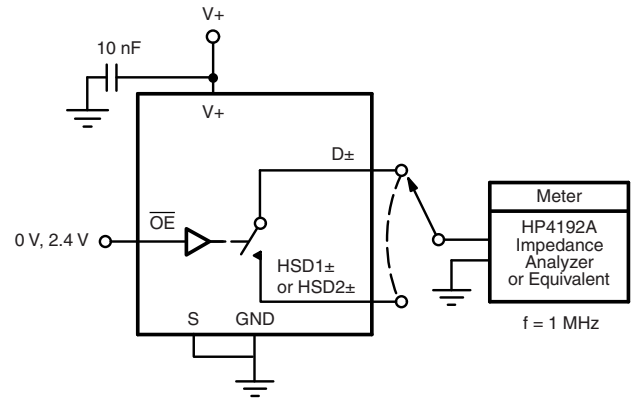

Figure 2. Break-Before-Make Interval



IN depends on switch configuration: input polarity determined by sense of switch.

Figure 3. Charge Injection

**TEST CIRCUITS**

**Figure 4. Off-Isolation**

**Figure 5. Channel Off/On Capacitance**

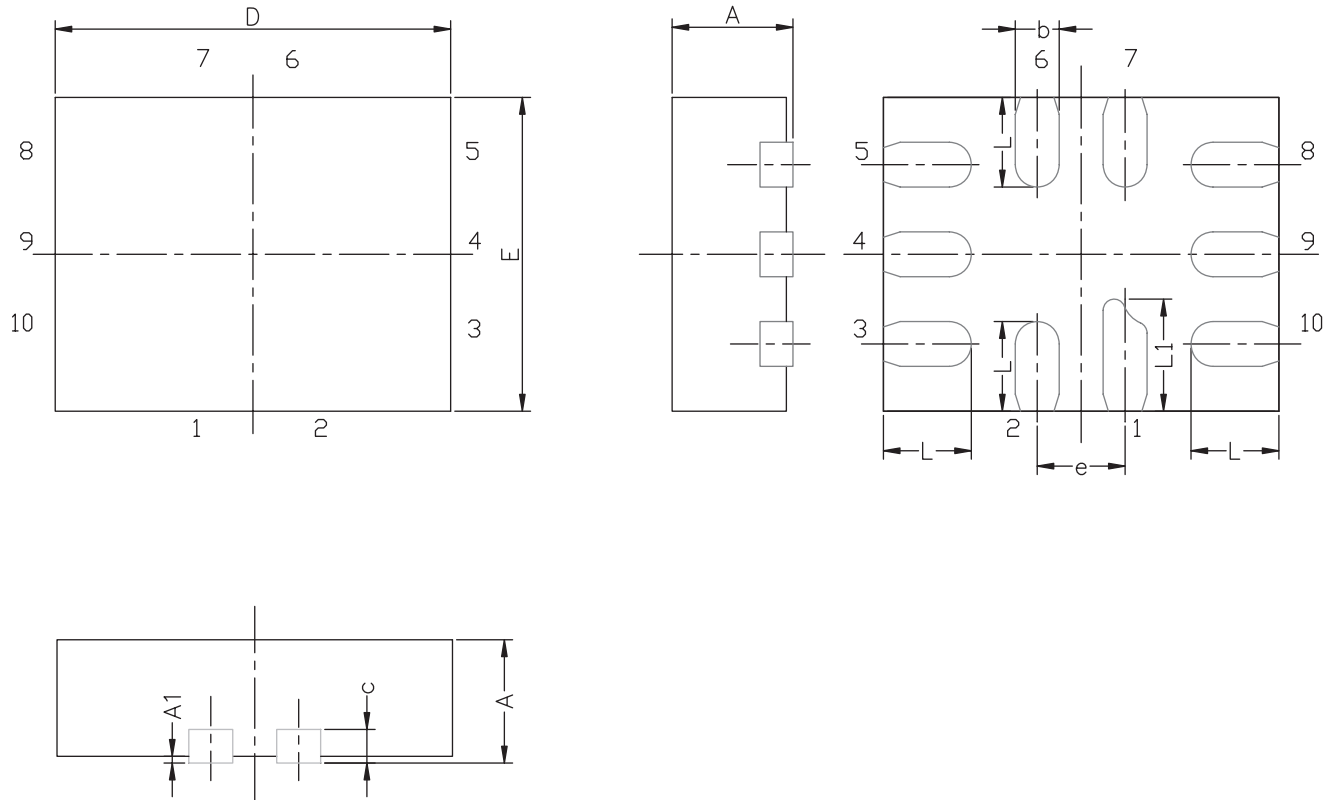
Vishay Siliconix maintains worldwide manufacturing capability. Products may be manufactured at one of several qualified locations. Reliability data for Silicon Technology and Package Reliability represent a composite of all qualified locations. For related documents such as package/tape drawings, part marking, and reliability data, see [www.vishay.com/ppg?68379](http://www.vishay.com/ppg?68379).

## MINI QFN-10L CASE OUTLINE



DIM	MILLIMETERS			INCHES		
	MIN.	NAM.	MAX.	MIN.	NAM.	MAX.
A	0.50	0.55	0.60	0.0197	0.0217	0.0236
A1	0.00	-	0.05	0.000	-	0.002
b	0.15	0.20	0.25	0.006	0.008	0.010
c	0.15 REF			0.006 REF		
D	1.75	1.80	1.85	0.069	0.071	0.073
E	1.35	1.40	1.45	0.053	0.055	0.057
e	0.40 BSC			0.016 BSC		
L	0.35	0.40	0.45	0.014	0.016	0.018
L1	0.45	0.50	0.55	0.0177	0.0197	0.0217

ECN T-07039-Rev. A, 12-Feb-07  
DWG: 5957





## Disclaimer

ALL PRODUCT, PRODUCT SPECIFICATIONS AND DATA ARE SUBJECT TO CHANGE WITHOUT NOTICE TO IMPROVE RELIABILITY, FUNCTION OR DESIGN OR OTHERWISE.

Vishay Intertechnology, Inc., its affiliates, agents, and employees, and all persons acting on its or their behalf (collectively, "Vishay"), disclaim any and all liability for any errors, inaccuracies or incompleteness contained in any datasheet or in any other disclosure relating to any product.

Vishay makes no warranty, representation or guarantee regarding the suitability of the products for any particular purpose or the continuing production of any product. To the maximum extent permitted by applicable law, Vishay disclaims (i) any and all liability arising out of the application or use of any product, (ii) any and all liability, including without limitation special, consequential or incidental damages, and (iii) any and all implied warranties, including warranties of fitness for particular purpose, non-infringement and merchantability.

Statements regarding the suitability of products for certain types of applications are based on Vishay's knowledge of typical requirements that are often placed on Vishay products in generic applications. Such statements are not binding statements about the suitability of products for a particular application. It is the customer's responsibility to validate that a particular product with the properties described in the product specification is suitable for use in a particular application. Parameters provided in datasheets and/or specifications may vary in different applications and performance may vary over time. All operating parameters, including typical parameters, must be validated for each customer application by the customer's technical experts. Product specifications do not expand or otherwise modify Vishay's terms and conditions of purchase, including but not limited to the warranty expressed therein.

Except as expressly indicated in writing, Vishay products are not designed for use in medical, life-saving, or life-sustaining applications or for any other application in which the failure of the Vishay product could result in personal injury or death. Customers using or selling Vishay products not expressly indicated for use in such applications do so at their own risk and agree to fully indemnify and hold Vishay and its distributors harmless from and against any and all claims, liabilities, expenses and damages arising or resulting in connection with such use or sale, including attorneys fees, even if such claim alleges that Vishay or its distributor was negligent regarding the design or manufacture of the part. Please contact authorized Vishay personnel to obtain written terms and conditions regarding products designed for such applications.

No license, express or implied, by estoppel or otherwise, to any intellectual property rights is granted by this document or by any conduct of Vishay. Product names and markings noted herein may be trademarks of their respective owners.

## Material Category Policy

**Vishay Intertechnology, Inc. hereby certifies that all its products that are identified as RoHS-Compliant fulfill the definitions and restrictions defined under Directive 2011/65/EU of The European Parliament and of the Council of June 8, 2011 on the restriction of the use of certain hazardous substances in electrical and electronic equipment (EEE) - recast, unless otherwise specified as non-compliant.**

**Please note that some Vishay documentation may still make reference to RoHS Directive 2002/95/EC. We confirm that all the products identified as being compliant to Directive 2002/95/EC conform to Directive 2011/65/EU.**